

(19) **DANMARK**

(10) **DK/EP 3478886 T3**



(12) **Oversættelse af
europæisk patentskrift**

Patent- og
Varemærkestyrelsen

-
- (51) Int.Cl.: **D 04 H 1/4209 (2012.01)** **C 03 C 25/00 (2018.01)** **D 04 H 1/4218 (2012.01)**
E 04 B 1/62 (2006.01)
- (45) Oversættelsen bekendtgjort den: **2025-01-02**
- (80) Dato for Den Europæiske Patentmyndigheds bekendtgørelse om meddelelse af patentet: **2024-11-27**
- (86) Europæisk ansøgning nr.: **17740638.6**
- (86) Europæisk indleveringsdag: **2017-06-29**
- (87) Den europæiske ansøgnings publiceringsdag: **2019-05-08**
- (86) International ansøgning nr.: **EP2017066229**
- (87) Internationalt publikationsnr.: **WO2018002280**
- (30) Prioritet: **2016-06-30 GB 201611398**
- (84) Designerede stater: **AL AT BE BG CH CY CZ DE DK EE ES FI FR GB GR HR HU IE IS IT LI LT LU LV MC MK MT NL NO PL PT RO RS SE SI SK SM TR**
- (73) Patenthaver: **Knauf Insulation SPRL, Rue de Maestricht 95, 4600 Visé, Belgien**
- (72) Opfinder: **GUILLEMOT, Gwenaël, c/o ARC-IP, Rue Emile Francqui 4, 1435 Mont-Saint-Guibert, Belgien**
- (74) Fuldmægtig i Danmark: **Novagraaf Brevets, Bâtiment O2, 2 rue Sarah Bernhardt CS90017, F-92665 Asnières-sur-Seine cedex, Frankrig**
- (54) Benævnelse: **MINERALULDSISOLERINGSMÅTTE**
- (56) Fremdragne publikationer:
CN-A- 104 532 973
CN-U- 202 324 229
CN-U- 202 627 242
US-A1- 2007 154 695

DESCRIPTION

Description

[0001] This invention relates to a mineral wool insulating element, notably to a meshed mineral wool mat, and to structures comprising a mineral wool insulating element. As used herein the term meshed mineral wool mat means a mineral wool mat held together by being sandwiched between meshes covering its major surfaces.

[0002] A known type of meshed mineral wool mat comprises a rock mineral wool blanket provided with a galvanized steel mesh, typically chicken wire, covering one major surface and having galvanized steel wire stitched through the mat such that the mineral wool blanket is sandwiched and held between the mesh at one major surface and the stitching at its other major surface. Such products are often referred to as "wired mat". Example of insulating elements are disclosed in CN104532973, CN202627242, CN202324229 and US2007/154695.

[0003] In accordance with one of its aspects, the present invention provides a mineral wool insulating mat as defined in claim 1. The dependent claims define preferred and/or alternative embodiments.

[0004] The non-metallic mesh may be an ensemble or an assembly of threads with apertures or open interstices between the threads; it may be a net or a web of threads. It may be a netting, a scrim, a fleece, a veil or a lattice. The terminology "non-metallic mesh" as used herein means a mesh comprising a non-metallic material; preferably, the non-metallic mesh consists of or consists essentially of non-metallic material(s). The non-metallic mesh may be a woven or non-woven material, for example a mineral fibre veil; it may comprise a woven textile or a net. It may be loosely netted, notably in the form of an openwork fabric made of threads that are knotted or otherwise secured together at regular intervals. The threads of the non-metallic mesh may be woven, knitted, crocheted, braided, layered and/or glued. The non-metallic mesh may have at least 5, at least 10 or at least 15 threads per centimetre, in its transverse and/or longitudinal direction.

[0005] The non-metallic mesh may comprise fibres or threads selected from mineral fibres, basalt fibres, glass fibres, carbon fibres, natural fibres, synthetic fibres, organic fibres, polyvinyl alcohol (PVA), polypropylene (PP), polyester (PES), fibres, polyethylene (PE) fibres, polyethylene terephthalate (PET) fibres, polyamide fibres, polysulphone fibres, aramid fibres, para-aramid fibres and poly paraphenylene terephthalamide fibres (eg poly(p-phenyleneterephthalamide) fibres). The fibres or threads may comprise single fibres or a plurality of fibres arranged to form a single thread, for example by being intertwined.

[0006] The mesh may comprise openings or interstices, notably when it has a woven or netted

structure. Such openings or interstices, notably at portions covering at least 50%, at least 60%, at least 70% or at least 80% of the area of the major surface of the mineral wool blanket, may have an area which is $\geq 0.5 \text{ mm}^2$, $\geq 1 \text{ mm}^2$, $\geq 10 \text{ mm}^2$, $\geq 20 \text{ mm}^2$, $\geq 80 \text{ mm}^2$, $\geq 100 \text{ mm}^2$, $\geq 200 \text{ mm}^2$ or $\geq 400 \text{ mm}^2$ and/or $\leq 2500 \text{ mm}^2$, $\leq 2000 \text{ mm}^2$ ≤ 1000 or $\leq 800 \text{ mm}^2$. The mesh may comprise substantially square or rectangular openings; one or each side or such square or rectangular openings may be $\geq 20\text{mm}$, $\geq 25\text{mm}$, $\geq 30\text{mm}$ $\geq 35\text{mm}$ or $\geq 40\text{mm}$ and/or $\leq 70\text{mm}$, $\leq 65\text{mm}$ or $\leq 60\text{mm}$. For example, square opening of a size within the range $20 \text{ mm} \times 20 \text{ mm}$ to $50 \text{ mm} \times 50 \text{ mm}$, for example about $40 \text{ mm} \times 40 \text{ mm}$, may provide a suitable combination of mechanical resistance and efficient use of material. Openings or interstices at one or more edges of the mesh may be of a different size, notable of a smaller size, than openings or interstices at a central portion of the mesh. This may enable the mesh to have greater resilience, strength or tear resistance at its edges, notably to facilitate attachment at the edges and/or avoid damage or fraying of the edges. The interstices or openings may be substantially square, rectangular, circular, triangular, hexagonal or diamond shaped.

[0007] The non-metallic mesh may have an ultimate tensile strength (ie at breakage), uniaxial or biaxial, which is $\leq 20 \text{ kN/m}$, $\leq 15 \text{ kN/m}$, $\leq 10 \text{ kN/m}$ or $\leq 8 \text{ kN/m}$ notably as measured according to ISO 10319:2015. The non-metallic mesh preferably has sufficient tensile resistance to withstand the force of two edges or two points of the mesh being pulled apart with a force which is $\geq 100 \text{ N}$, $\geq 200 \text{ N}$ or $\geq 300 \text{ N}$, for example during attachment of a fastener to connect the two edges or points of the mesh when the insulating element is wrapped around a pipe or secured to by the mesh to a supporting structure.

[0008] The non-metallic mesh, particularly a surface of the non-metallic mesh, may be coated, for example with an organic coating, an inorganic coating or a metal coating. The coating may be a fire resistant coating; it may improve fire resistance of the mesh and/or the insulating element. Particularly in the case of a mesh comprising mineral fibres, for example basalt fibres, the coating may facilitate cutting of the mesh, for example using scissors and/or may prevent relative movement between individual fibres of the mesh. For example, the non-metallic mesh may comprise coated basalt fibres, notably basalt fibres coated with a non-combustible coating.

[0009] Preferably, both meshes i.e. the mesh arranged at the first major surface of the mineral wool blanket and the mesh arranged at the second major surface, each comprises a non-metallic mesh. Each of the first mesh and the second mesh may have the same construction; alternatively, each may have a different structure. Each of the first mesh and second mesh may or may not be made of the same material(s).

[0010] One or each of the first and second meshes may be secured to its corresponding surface of the mineral wool blanket via a bonding agent. The bonding agent may be an organic or inorganic binder, adhesive or a glue. Preferably, the bonding agent is fire-resistant; it may be water glass.

[0011] When arranged at the surface of the mineral wool blanket, each of the first and second

meshes may extend beyond the edge of the blanket and form flaps. The flaps of the first and second meshes may be turned down along the edges of the blanket and further overlap. Alternatively, the flaps may project beyond the edges of the blanket and be superimposed. The overlapped and/or superimposed flaps of the first and second meshes may be secured together by fasteners.

[0012] The first and second meshes may form a sleeve which surrounds the mineral wool blanket. The sleeve may be formed by wrapping the meshes around the mineral wool blanket; particularly in this case, the sleeve may be provided with fasteners at three sides, with a fourth side being formed by a fold in the sleeve. The sleeve may be pre-formed, for example in the form of a tube into which the mineral wool blanket can be introduced; particularly in this case, the sleeve may be provided with fasteners at two opposite sides, with two other opposite sides each being formed by a fold in the sleeve which may also provide a fastener.

[0013] One or each of the non-metallic meshes may have a weight $\geq 20 \text{ g/m}^2$, $\geq 50 \text{ g/m}^2$, $\geq 100 \text{ g/m}^2$ or $\geq 200 \text{ g/m}^2$ and/or $\leq 500 \text{ g/m}^2$, $\leq 1000 \text{ g/m}^2$ or $\leq 2000 \text{ g/m}^2 \leq 3000 \text{ g/m}^2$.

[0014] The fasteners may comprise threads; they may comprise metal threads, for example wire, notably steel wire for example galvanized steel wire or stainless steel wire. Preferably, when the fasteners comprise threads they comprise non-metallic threads. The term "non-metallic thread" as used herein means a thread comprising a non-metallic material. The non-metallic threads may consist of or consist essentially of non-metallic material(s). Threads which are entirely non-metallic are preferred, notably to facilitate cutting and/or recycling and/or corrosion resistance. Non-metallic threads reduce the risk of injuries during the handling and avoid or reduce thermal bridges. The non-metallic threads may comprise mineral fibres, organic fibres, basalt fibres, glass fibres, carbon fibres, synthetic fibres, polyethylene terephthalate (PET) fibres, polysulphone fibres, aramid fibres, para-aramid fibres or poly paraphenylene terephthalamide fibres. The threads may be formed by extrusion and/or by assembly of a plurality of fibres. The threads may have a diameter which is $\geq 0.005 \text{ mm}$, $\geq 0.01 \text{ mm}$, $\geq 0.1 \text{ mm}$, $\geq 0.5 \text{ mm}$, $\geq 1 \text{ mm}$ or $\geq 2 \text{ mm}$, and/or $\leq 2.5 \text{ mm}$ or $\leq 5 \text{ mm}$. Threads of aramid fibres, para-aramid fibres or poly paraphenylene terephthalamide fibres provide particularly suitable properties, notably when used as stitching.

[0015] The fasteners comprise one or more threads that are sewn or stitched through the mineral wool blanket. The thread(s) form(s) the second mesh; such a mesh is a network of one or more threads formed by the portions of the thread(s) passing along a major surface of the mineral wool blanket. The thread(s) may follow a path as follows: starting from the first major surface, the thread enters the mineral blanket, passes throughout the mineral blanket, emerges at the second major surface of the blanket, continues along that second major surface, returns back into the mineral wool blanket, passes again through the mineral blanket and emerges at the first major surface of the blanket, continues along the first major surface, returns back into the mineral wool blanket, passes again through the mineral blanket and emerges at second first major surface of the blanket. This path may be repeated a plurality of

times to provide a stitching. The fasteners may comprise a plurality of stitching, for example a plurality of substantially parallel stitching through the mineral wool blanket. The stitching of threads through the mineral wool blanket is preferably slack in order to give some flexibility to the mineral wool insulating element. Such flexibility helps maintain the integrity of the mineral wool insulating element when it is submitted to several folding and unfolding steps. This is especially the case when the insulating elements are rolled for transportation, unrolled on site for installation and wrapped around elements, for example pipes or tanks, to be insulated.

[0016] The fasteners may comprise closing element(s), notably closing element(s) arranged to secure together edges or flaps of the first and second mesh. The closing element(s) may comprise a snap, hook, zip, loop or eyelet; it may comprise one or more threads arranged to pass through edges or flaps of the first and second mesh so as to secure the edges or flaps together. It may comprise one or more threads arranged to extend beyond the edges or flaps of the first and second mesh. The closing element(s) may comprise one or more threads arranged to be intertwined (or criss-crossed or netted) so as to secure the edges or flaps together. The one or more threads of the closing element may be tied to secure the edges or flaps together.

[0017] The closing element(s) may comprise a reversible closure allowing closure, reopening and re-closure at least one time. The closing element may comprise a zip or a hook- and-loop fastener. A reversible closure facilitates inspection and/or replacement of a portion of the mineral wool blanket and access to an installation covered by the insulating mat. This is useful during maintenance and inspection.

[0018] The mineral wool blanket of the mineral wool insulating element may comprise non-woven mineral fibres. The mineral fibres may comprise fibres selected from rock fibres, glass fibres and mixtures of rock and glass fibres. The fibres may have an average diameter between 2 μm and 9 μm . The majority of the fibres of the mineral wool blanket may be orientated substantially parallel to its major surfaces. Alternatively, the majority of the fibres of the mineral wool blanket may be orientated substantially perpendicular to its major surfaces. The mineral wool blanket may comprise mineral wool lamellas in which the fibre orientation is predominantly perpendicular to the major surfaces of the blanket.

[0019] Particularly for applications with low service temperatures ($< 300^\circ\text{C}$), notably between 100°C and 300°C , the mineral wool blanket may comprise at least 90% by weight glass mineral wool. Particularly for applications with higher service temperatures ($>300^\circ\text{C}$), notably between 450°C and 750°C , a mineral wool blanket comprising at least 90% by weight rock mineral fibres is preferred, notably for its temperature resistance. The fibres of the glass mineral wool may: comprise > 55 wt-% silicon oxide (SiO_2) and/or < 10 wt-% aluminium oxide (Al_2O_3); and/or an alkali/alkaline-earth ratio of their composition which is > 1 ; and/or a combined quantity of CaO and $\text{MgO} < 20$ wt-%; and/or a combined quantity of Na_2O and $\text{K}_2\text{O} > 8$ wt%; and/or a density ≥ 5 kg/m^3 and/or ≤ 60 kg/m^3 . The rock mineral fibres may: comprise between 30 and 55 wt-% SiO_2 and/or between 10 and 30 wt-% Al_2O_3 ; and/or an alkali/alkaline-

earth ratio of their composition which is < 1 ; and/or a combined quantity of CaO and MgO ranging from 20 to 30 wt-%; and/or a combined quantity of Na₂O and K₂O < 8 wt-%; and/or a density ≥ 65 kg/m³ and/or ≤ 200 kg/m³.

[0020] The mineral wool blanket may comprise a binder, notably an organic binder. When an organic binder is used, the quantity of the binder may be ≤ 5 wt%, ≤ 4 wt%, ≤ 3 wt%, ≤ 2 wt%, ≤ 1.5 wt%, ≤ 1 wt%, ≤ 0.8 wt%, ≤ 0.5 wt%, ≤ 0.2 wt% or ≤ 0.1 wt%. Preferably, when a binder is used the quantity of binder is ≥ 0.2 and ≤ 0.8 wt-%. The absence of significant quantities of organic binder is helpful when fire resistant properties are desired. The insulating blanket and/or insulating element may be free of organic binder. The mineral wool blanket may have an organic content and/or a hydrocarbon content which is ≤ 0.5 wt%, ≤ 0.2 wt% or ≤ 0.1 wt%. The organic content and/or the hydrocarbon content may include organic compounds comprised in any organic binder. Preferably the mineral wool blanket is substantially free of organic materials with an organic content and/or a hydrocarbon content which is ≤ 0.5 wt%.

[0021] The mineral wool blanket may be provided with a reinforcing framework; this may be located on at least one major surface or inside the mineral wool blanket body. Preferably, the reinforcing framework is flexible. The reinforcing framework may be a mesh of the type described herein. The framework may be stitched into and/or adhered to the mineral wool blanket. In addition to providing improved mechanical strength, a reinforcing framework inside the blanket body helps maintain homogeneity of the insulation properties, notably homogeneity in the density of the mineral wool blanket, notably by helping to avoid stretching or pulling apart of the mineral fibres during installation.

[0022] The mineral wool insulating element may have a density which is ≥ 5 kg/m³, ≥ 10 kg/m³, ≥ 20 kg/m³, ≥ 40 kg/m³, ≥ 60 kg/m³ or ≥ 80 kg/m³ and/or ≤ 100 kg/m³, ≤ 120 kg/m³, ≤ 140 kg/m³, ≤ 200 kg/m³ or ≤ 250 kg/m³. The mineral wool insulating element may have dimensions before installation and/or when installed which include:

- a thickness which is ≥ 2 cm and/or ≤ 40 cm; or
 - a thickness which is ≥ 3 cm or ≥ 5 cm or ≥ 7 cm and/or ≤ 30 cm, or ≤ 20 cm ≤ 15 cm or ≤ 10 cm or ≤ 8 cm; and/or
 - a length which is ≥ 0.5 m, ≥ 1 m or ≥ 2 m and/or ≤ 9 m, or ≤ 6 m or ≤ 4 m; and/or
 - a width which is ≥ 0.2 m, ≥ 0.4 m or ≥ 0.5 m and/or ≤ 2.8 m, ≤ 2 m, ≤ 1.5 m or ≤ 1.2 m.
- The thickness of the mineral wool insulating mat is determined in accordance with the relevant EN product standard, notably associated with the relevant EN measurement standard, for example in accordance with EN13162 or EN14303, as applicable on 30 June 2016.

[0023] The mineral wool insulating mat may have a fire rating of at least a class B and preferably class A2 or A1 according to EN 13501-1 and test method EN 13820. It may be rated for use at continuous operating temperatures up to a maximum service temperature (MST)

which is $\geq 100\text{ }^{\circ}\text{C}$, $\geq 150\text{ }^{\circ}\text{C}$, $\geq 200\text{ }^{\circ}\text{C}$, $\geq 300\text{ }^{\circ}\text{C}$, $\geq 400\text{ }^{\circ}\text{C}$, $\geq 500\text{ }^{\circ}\text{C}$ or $\geq 600\text{ }^{\circ}\text{C}$ and/or $\leq 1000\text{ }^{\circ}\text{C}$ or $\leq 800\text{ }^{\circ}\text{C}$. The MST is determined according to EN 14706.

[0024] The mineral wool insulating element may comprise a facing, for example a veil or a metallised foil, notably an aluminium foil, positioned over one or each of its major surfaces. The facing may be positioned at a major surface of the mineral wool blanket a) between the mineral wool blanket and the associated non-metallic mesh or b) over the associated mesh. The facing may be bonded to the mineral wool insulating element, for example with an inorganic adhesive.

[0025] The mineral wool insulating element may be substantially flexible or non-rigid to allow it to be wrapped or rolled around and/or to conform to the contours of a supporting substrate, when installed. The mineral wool insulating mat may be provided in the form of a roll, notably a roll having a height corresponding to the widths mentioned above.

[0026] The mineral wool mat may have a thermal conductivity (λ) in mW/(mK) according to EN12667 of:

≤ 45 or ≤ 42 at 50°C ; and/or

≤ 50 or ≤ 49 at 100°C ; and/or

≤ 70 or ≤ 69 at 200°C ; and/or

≤ 100 or ≤ 98 at 300°C ; and/or

≤ 118 or ≤ 115 at 400°C ; and/or

≤ 153 or ≤ 150 at 500°C ; and/or

≤ 201 or ≤ 198 at 600°C .

[0027] The mineral wool insulating element may be particularly suitable for providing thermal and/or acoustic and/or fire insulation, for example for: buildings insulation; marine insulation; insulation of heating, ventilating and air conditioning (HVAC) ducts; and industrial insulation, for example insulation of pipes (notably metal pipes), pipe elbows, boilers and tanks. When non-rigid or flexible, mineral wool insulating elements are particularly suitable for wrapping around large diameter high temperature pipework. The meshed mat may significantly reduce noise generated by liquid and granular materials transported through pipework at high velocity.

[0028] In addition to retaining the mineral wool blanket between them, non-metallic meshes preferably provide an absence of sharp projections (the metal meshes of wired mats must be carefully handled to avoid scratches, notably from loose metallic threads ends). The non-metallic meshes, particularly when combined with non-metallic fasteners, are also particularly suitable for providing dielectric insulating mats and/or avoiding the risk of electrical conduction through the mineral wool blanket. Furthermore, the non-metallic meshes and non-metallic

fasteners, particularly when they consist of or consist essentially of non-metallic material(s) may be introduced in a mineral wool melting furnace for recycling the mineral wool along with the mineral wool waste notably without removal of the meshes and fasteners; this greatly facilitates recycling. The use of non-metallic meshes may be used to minimise thermal bridges through the mineral wool blanket and/or provide a surface which is corrosion resistant, for example rust resistant and/or which is suitable for contact with steel supporting structures or pipes. In some cases, use of non-metallic meshes and/or non-metallic fasteners provides advantageous corrosion resistance; this may facilitate use in circumstance where the mineral wool insulating element may be exposed to corrosive surroundings, for example salt water spray or mist, and avoid the necessity for corrosion resistant metal meshes of, for example, specific grades of stainless steel. The mesh or meshes, notably in combination with the fasteners, may contribute to providing resilience to the mineral wool insulating element, for example contributing to recovery of the shape and or dimensions following compression, for example following compression for packaging. In some cases, the mineral wool insulating element may be configured to be folded or wrapped around a support, for example wrapped around an arc having a radius of 10cm and a length of 8 cm, without plastic deformation or "memory effect" of the mineral wool insulating element; in this case, the mineral wool insulating element preferably resumes its original configuration, for example a substantially planar configuration, when unwrapped and can thus be easily wrapped around a pipe or other support, removed for inspection or maintenance and re-wrapped around the same or a different support. The use of non-metallic meshes and fasteners may also facilitate cutting of the mineral wool element; this is a significant advantage, notably on site, when workers have to resize the insulating element to fit closely to the geometry of the desired installation. Preferably, the non-metallic mesh, notably in combination with the fasteners, provide a combination of two or more of these features.

[0029] The mineral wool blanket may have a homogeneous density throughout its thickness. Alternatively, the density of the mineral wool blanket be non-homogeneous, for example varying progressively or step wise through its thickness. For example, the density at a surface layer of one of the major surfaces of the mineral wool blanket, notably at a surface layer having a thickness of 5mm, 10mm, 15mm or 20 mm, may be greater than the density of a surface layer at the other major surface having the same thickness, notably with a difference in density which is $\geq 10 \text{ kg/m}^3$, $\geq 20 \text{ kg/m}^3$, $\geq 30 \text{ kg/m}^3$ or $\geq 40 \text{ kg/m}^3$. This may be achieved by use of a dual density mineral wool blanket, that is to say a blanket provided with a surface layer which has undergone greater thickness compression than another portion of the blanket prior to being assembled therewith. Assembly of the surface layer may comprise adhesion, for example in a curing oven, and/or assembly by means of the fasteners of the mineral wool insulating element. A high surface density may be used to enhance fire or flame resistance, for example for the external surface of a pipe or ducting insulation, whilst the lower density of the remaining portion of the mineral wool blanket, for example arranged toward the inside surface of a pipe or ducting insulation, may be used to enhance thermal insulation by reducing the thermal conductivity (λ) value).

[0030] In accordance with a further aspect, the present invention provides a structure

comprising a mineral wool insulating element as described herein folded or wrapped around a support. In this case, the mineral wool insulating element is preferably substantially flexible or non-rigid to allow it to be wrapped or rolled around and/or to conform to the contours of the support. The support may comprise: a support structure; a building support, for example a beam notably a metal beam, for example an I section beam; a pipe, pipe elbow, boiler or tank, notably of meta; a marine structure, for example part of the structure, hull, deck, bulkhead, floor, airducts, pipes or fittings of a marine vessel; a heating, ventilating or air conditioning duct. Particularly in the case of a marine structure, the mineral wool insulation may be secured to a support structure, notably a metal support structure, by pins which are secured to the support structure, for example by welding, and which pass partially or entirely through the mineral wool insulating element. Attachment by pins is particularly suitable for walls and/or ceilings of a marine or other structure. The mineral wool insulating element may be hung from such pins, for example subsequent to securing of the pins to the support structure. A head of the pin may contact the non-metallic mesh of the mineral wool insulating element; the non-metallic mesh may be arranged between the head of the pin and the support structure.

[0031] Different embodiments will now be described, by way of example only, with reference to the accompanying drawing of which:

Fig. 1 is a perspective view of a first embodiment of a mineral wool insulating element;

Fig. 2 is a plan view of the mineral wool insulating element of Fig 1;

Fig. 3 is a perspective view of a second embodiment;

Fig. 4 is a perspective view of a third embodiment;

Fig. 5 is a perspective view of a fourth embodiment;

Fig. 6 is a cross-section of a fifth embodiment;

Fig. 7 is a plan view of the mineral wool insulating element of Fig 6;

Fig. 8 is a cross-section through a sixth embodiment of a mineral wool insulating element;

Fig. 9 is a cross-section through a seventh embodiment;

Fig. 10 and Fig 11 are cross-sections through an eighth embodiment;

Fig. 12 is a perspective view of a ninth embodiment.

Only embodiments covered by the scope of the claims form part of the invention.

The drawings are not intended to be to scale. For illustrative purposes i) some elements which are positioned at or on surfaces of the mineral wool blanket, notably the meshes, are shown spaced from the surfaces and ii) when the mesh comprises an open structure having interstices, this is not illustrated in the perspective views.

[0032] Fig 1 and Fig 2 illustrate a first embodiment of a mineral wool insulating element 10

which consists of a rock mineral wool blanket 11 sandwiched between a first non-metallic mesh 12 arranged at a first major surface 13 of the mineral wool blanket and a second non-metallic mesh 14 arranged at a second major surface 15 of the mineral wool blanket. Both of the non-metallic meshes 12 and 14 are made of intertwined carbon fibres 21 with square openings 22 of an internal aperture area of 9 cm². The first and the second non-metallic meshes 12 and 14 are connected by a plurality of fasteners 16 consisting of aramid threads which are sewn through superimposed flaps of the non-metallic meshes projecting beyond the edges of the mineral wool blanket. In this manner the meshes 12, 14 joined by the sewn threads form a sleeve around the blanket 11 which retains the mineral wool blanket sandwiched between the first and the second non-metallic meshes. The blanket 11 may include a low quantity of organic binder, for example between 0.3%wt and 0.8% wt, for example to facilitate handling during manufacturing.

[0033] In the embodiment of Fig 3 illustrating a mineral wool insulating element 30, first and second non-metallic meshes 32 and 34 arranged on respective major surfaces 33, 35 are connected by a plurality of fasteners 36 comprising threads which are sewn through overlapping flaps of the first and the second non-metallic meshes which extend along the side faces of a mineral wool blanket 31.

[0034] In another embodiment (not illustrated) the plurality of fasteners 16, 36 illustrated in Fig 1 or Fig 3 connecting the first and the second meshes are replaced with a system of hook and loop fasteners providing a reversible closure. In such embodiments one of the edges of the first and the second meshes comprises a strip equipped with hooks while the other opposite edge of other mesh comprises a strip equipped with loops.

[0035] In the embodiment shown in Fig 4 illustrating a mineral wool insulating element 40, first and second non-metallic meshes 42 and 44 arranged on respective major surfaces 43, 45 also form a sleeve which surrounds a mineral wool blanket 41 of a mineral wool insulating element 40. The sleeve is formed by wrapping a single piece of mesh around the mineral wool blanket and the sleeve is closed by connecting the flaps of the mesh 42 and 44 at their edges with staples or stitched threads. In the illustrated embodiment the edges of the flaps abut; alternatively, they may superimpose or overlap as illustrated respectively in Fig 1 and Fig 3. The sleeve is closed with fasteners 46 at three sides (only one side of closure is shown in Fig 4) with a fourth side 47 being formed by a fold in the sleeve which also provides a fastener connecting the two meshes.

[0036] In the embodiment of Fig. 5 illustrating a mineral wool insulating element 50, a sleeve comprising first and second non-metallic meshes 52, 54, which are arranged on respective major surfaces 43, 45, is pre-formed in the form of a tube into which a mineral wool blanket 51 can be introduced. The sides 57 of the sleeve act as fasteners which connect the first 52 and second 54 meshes together. The sleeve is also provided with fasteners at two opposite sides (not shown in Fig 5) to close its ends which are initially open.

[0037] Fig.6 and Fig 7 shows a mineral wool mat 60 comprising a rock mineral wool blanket 61

sandwiched between a first 62 and a second 64 non-metallic mesh arranged on respective major surfaces 63, 65 of the mineral wool blanket. The first and the second non-metallic meshes 62 and 64 are formed by aramid threads 66 which are sewn through the rock mineral wool blanket: each of the first and the second non-metallic meshes consisting of a network formed respectively by portions 67, 68 of the aramid threads 66 passing along the major surfaces 63, 65 of the mineral wool blanket. Portions 69 of the aramid threads 66 passing through the mineral wool blanket 61 form fasteners which connect the first and the second non-metallic meshes 62, 64 together so as to retain the mineral wool blanket sandwiched between them. Fig.7 shows the lengths 67 of the aramid threads passing along the major surfaces 63 and which form the first non-metallic mesh 62.

[0038] Fig 8 shows a mineral wool insulating mat 80 comprising of rock mineral wool blanket 81 sandwiched between a first non-metallic mesh 82 arranged at a first major surface 83 and a second non-metallic mesh 84 arranged at a second major surface 85. Each of the non-metallic meshes are made of woven aramid fibres having 10 mm square apertures between the fibres. The non-metallic meshes 82, 84 are connected by being sewn together with galvanised steel threads 86 that pass through the mineral wool blanket 81 and are stitched through the aramid meshes 82 and 84. Portions 87 of the galvanised steel threads which pass through the mineral wool blanket provide fasteners which connect the first and second non-metallic meshes together so as to retain the mineral wool blanket sandwiched between them.

[0039] In the arrangement shown in Fig 9, a first non-metallic mesh 92 arranged at a first major surface 93 of the mineral wool blanket 91 comprises the combination of i) aramid mesh 92a of woven poly paraphenylene terephthalamide fibres with square apertures of 15 mm between the fibres and ii) first surface portions 92b of aramid threads 96. The aramid threads 96 are sewn through the first aramid mesh 92a and through the mineral wool blanket 91. Second surface portions 97 of the aramid threads 96 passing along the second major surface 98 of the mineral wool blanket 91 form a second non-metallic mesh 94 whilst traversing portions 99 of the aramid threads 96 which pass through the mineral wool blanket provide fasteners which connect the first and second non-metallic meshes together.

[0040] Fig 10 and Fig 11 show an embodiment in which a reinforcing mesh is located inside the mineral wool blanket. The mineral wool blanket 100a, 100b is obtained by sandwiching a reinforcing mesh 101 between two partial mineral wool blankets 102, 103. In the illustrated embodiment of Fig 11 the reinforcing mesh is kept in place by stitching 104 similar to that of Fig 6.

[0041] Fig. 12 illustrates a mineral wool element 112 wrapped around a pipe 111 and having abutting edges of its non-metallic mesh 112 at its outer surface 114 wrapped sewn to form a closure line 113 thus retaining the insulating element in position around the pipe.

REFERENCES CITED IN THE DESCRIPTION

Cited references

This list of references cited by the applicant is for the reader's convenience only. It does not form part of the European patent document. Even though great care has been taken in compiling the references, errors or omissions cannot be excluded and the EPO disclaims all liability in this regard.

Patent documents cited in the description

- [CN104532973 \[0002\]](#)
- [CN202627242 \[0002\]](#)
- [CN202324229 \[0002\]](#)
- [US2007154695A \[0002\]](#)

PATENTKRAV

1. Mineraluldsisoleringsselement, der omfatter:

- et mineraluldsdække omfattende mineralfibre;

5 - et første ikke-metallisk net anbragt på en første hovedflade af mineraluldsdækket;

- et andet net anbragt på en anden hovedflade af mineraluldsdækket; og en flerhed af fastgørelsesanordninger omfattende tråde, der er syet gennem mineraluldsdækket og anbragt således, at de forbinder det første og det andet net med hinanden på en sådan måde, at mineraluldsdækket fastholdes klemmt inde
10 mellem det første og det andet net;

hvor mineraluldsisoleringsselementet er en mineraluldsmåtte, der holdes sammen ved at være klemmt inde mellem nettene, der dækker dens første hovedflade og dens anden hovedflade,

hvor nettene, der dækker den anden hovedflade, består af det andet net; og

15 hvor det andet net består af et netværk af en eller flere af trådene dannet af afsnit af tråden/trådene, der forløber langs mineraluldsdækkets anden hovedflade.

2. Mineraluldsisoleringsselement (90) ifølge krav 1, hvor fastgørelsesanordningerne (96) omfatter ikke-metalliske tråde.

3. Mineraluldsisoleringsselement (90) ifølge krav 2, hvor de ikke-metalliske
20 tråde omfatter mineralfibre, organiske fibre, basaltfibre, glasfibre, kulfibre, syntetiske fibre, polyethylenterephthalat- (PET)-fibre, polysulfonfibre, aramidfibre, para-aramidfibre eller polyparaphenylenterephthalamidfibre.

4. Mineraluldsisoleringsselement (90) ifølge krav 2 eller krav 3, hvor det første ikke-metalliske net (92) består af ikke-metallisk(e) materiale(r).

25 5. Mineraluldsisoleringsselement (90) ifølge krav 1, hvor fastgørelsesanordningerne (96) omfatter metaltråde.

6. Mineraluldsisoleringselement (90) ifølge krav 5, hvor metaltrådene omfatter stålwire.
7. Mineraluldsisoleringselement (90) ifølge et hvilket som helst af de foregående krav, hvor et hvilket som helst organisk bindemiddel, der er indeholdt i
5 mineraluldsdækket, er til stede i en mængde, der er $\leq 2,5$ vægt-%, fortrinsvis $\leq 1,0$ vægt-%, mere fortrinsvis $\leq 0,5$ vægt-%.
8. Mineraluldsisoleringselement (90) ifølge et hvilket som helst af de foregående krav, hvor det første ikke-metalliske net (92) omfatter kvadratiske eller rektangulære åbninger, hvor hver side af de kvadratiske eller rektangulære
10 åbninger er ≥ 20 mm og ≤ 70 mm.
9. Mineraluldsisoleringselement (90) ifølge et hvilket som helst af de foregående krav, hvor det første ikke-metalliske net (92) omfatter kvadratiske åbninger i intervallet 20 mm x 20 mm til 50 mm x 50 mm.
10. Mineraluldsisoleringselement (90) ifølge et hvilket som helst af de
15 foregående krav, hvor det første ikke-metalliske net (92) omfatter fibre valgt blandt naturfibre, syntetiske fibre, aramidfibre, para-aramidfibre, polyparaphenylenterephthalamidfibre, kulfibre, mineralfibre, basaltfibre og glasfibre.
11. Mineraluldsisoleringselement (90) ifølge et hvilket som helst af de foregående krav, hvor det første ikke-metalliske net (92) omfatter et vævet net
20 eller et løstvævet net.
12. Mineraluldsisoleringselement (90) ifølge et hvilket som helst af de foregående krav, hvilket mineraluldsisoleringselement har i det mindste en af følgende egenskaber:
- en tæthed i intervallet 5 kg/m³ til 250 kg/m³;
 - 25 - en tykkelse i intervallet 1 cm til 40 cm, i henhold til EN13162 eller EN14303;
 - hvor mineralfibrene omfatter fibre valgt blandt stenfibre, glasfibre og en blanding deraf;

- hvor det første og det andet net hver for sig har en vægt i intervallet 0,05 kg/m² til 3,0 kg/m²;

- hvor mineraluldsisoleringsselementet omfatter en brandklasse i henhold til EN 13501-1 valgt fra A2 og A1.

5 13. Mineraluldsisoleringsselement (90) ifølge et hvilket som helst af de foregående krav, hvilket mineraluldsisoleringsselement har en varmeledningsevne (λ) i mW/(mK) i henhold til EN12667 på:

≤ 45 eller ≤ 42 ved 50 °C; og/eller

≤ 50 eller ≤ 49 ved 100 °C; og/eller

10 ≤ 70 eller ≤ 69 ved 200 °C; og/eller

≤ 100 eller ≤ 98 ved 300 °C; og/eller

≤ 118 eller ≤ 115 ved 400 °C; og/eller

≤ 153 eller ≤ 150 ved 500 °C; og/eller

≤ 201 eller ≤ 198 ved 600 °C.

15 14. Isoleret konstruktion omfattende et rør og et mineraluldsisoleringsselement (90) ifølge et hvilket som helst af krav 1 til 13, der er viklet om røret.

15. Skibskonstruktion, der omfatter en bærende konstruktion, især et skibsdæk, et skot, et gulv, en luftkanal eller et rør og et mineraluldsisoleringsselement (90) ifølge et hvilket som helst af krav 1 til 13,
20 sammenbygget med skibskonstruktionen på en sådan måde, at det følger skibskonstruktionens konturer.

DRAWINGS

Drawing

Fig. 1

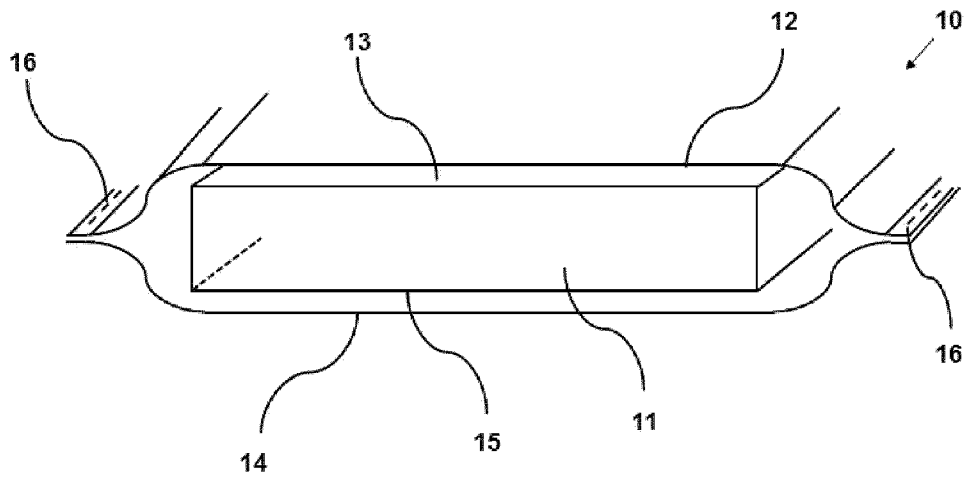

Fig. 2

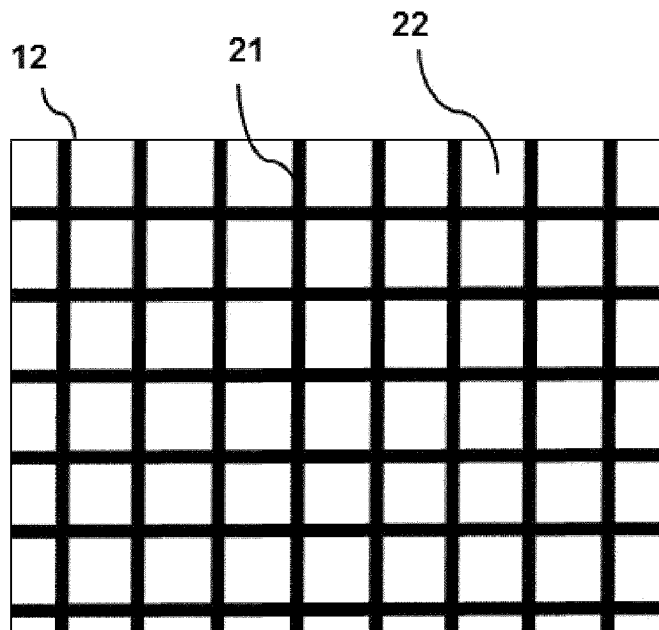

Fig. 3

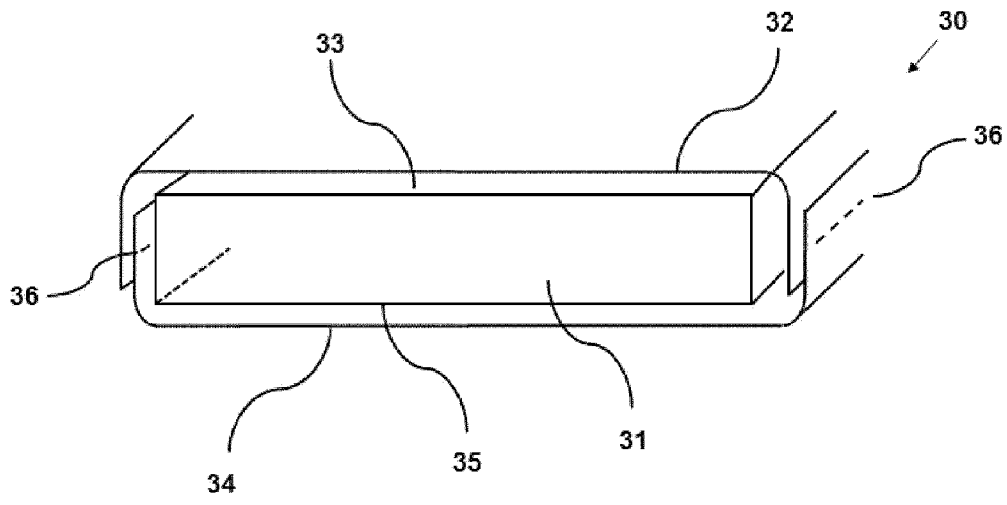

Fig. 4

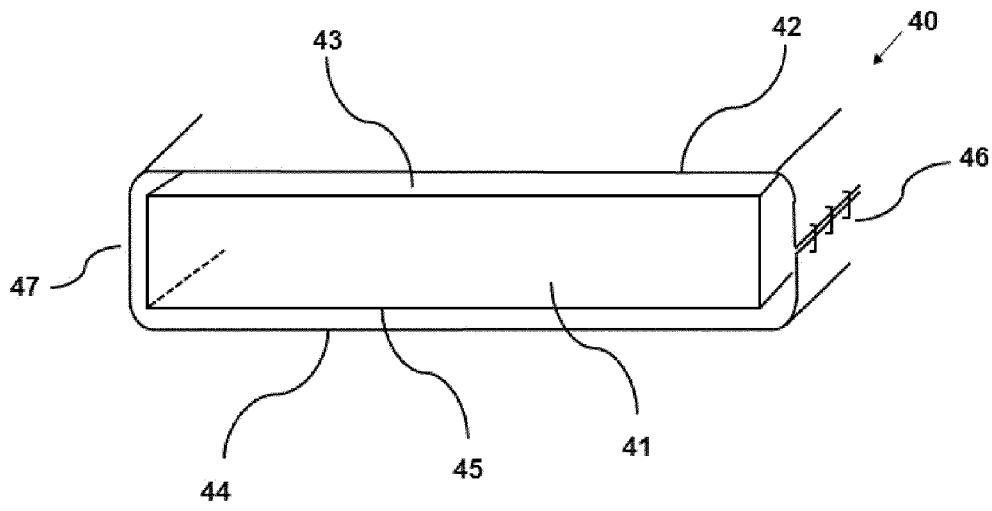

Fig. 5

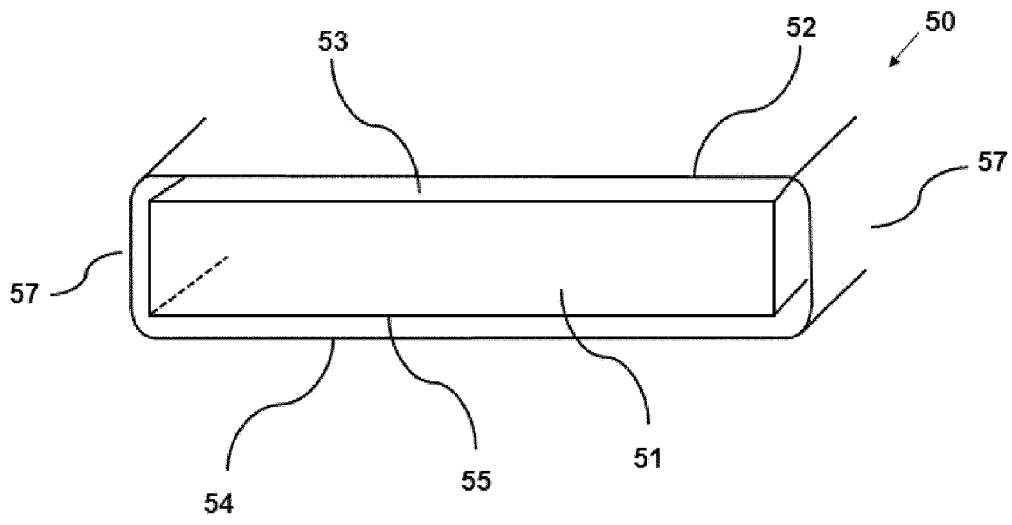

Fig. 6

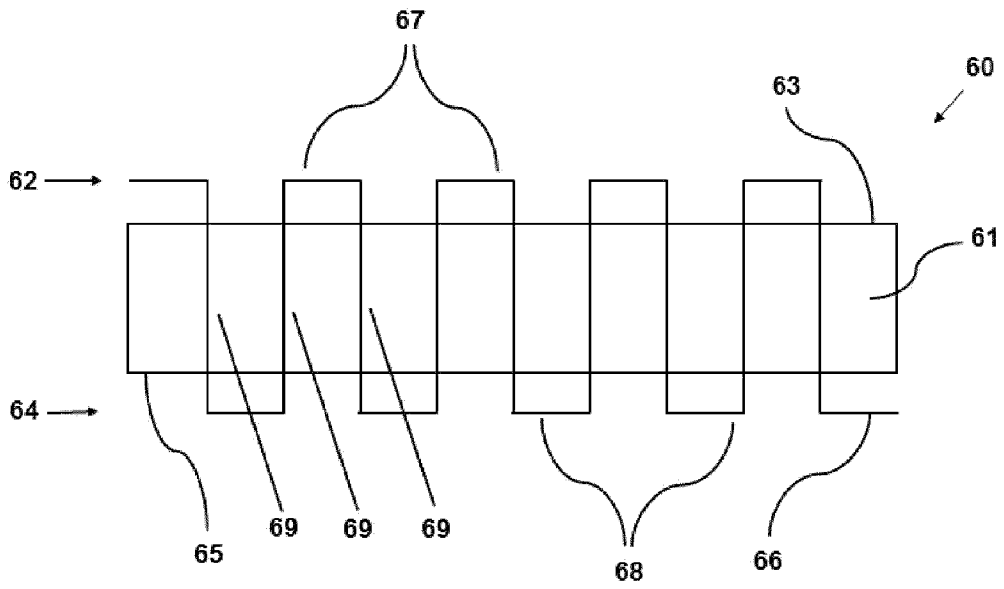

Fig. 7

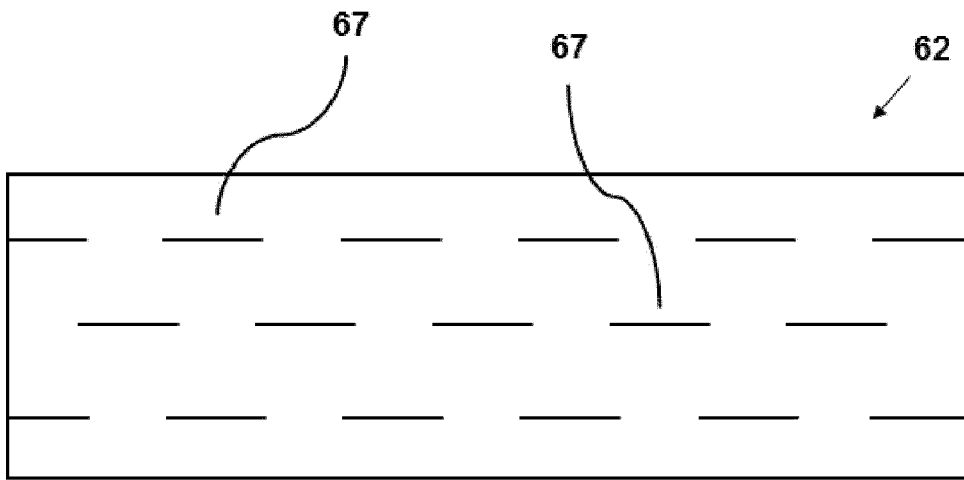

Fig. 8

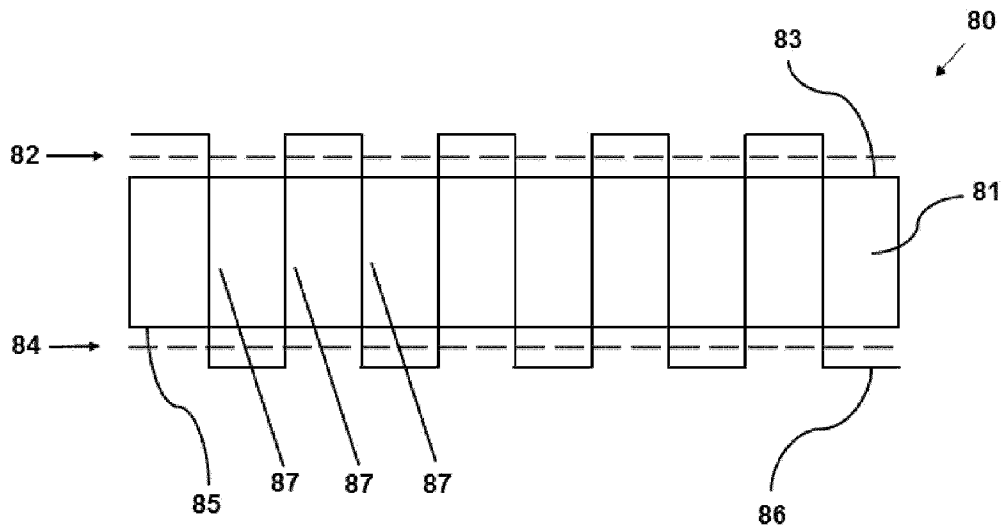

Fig. 9

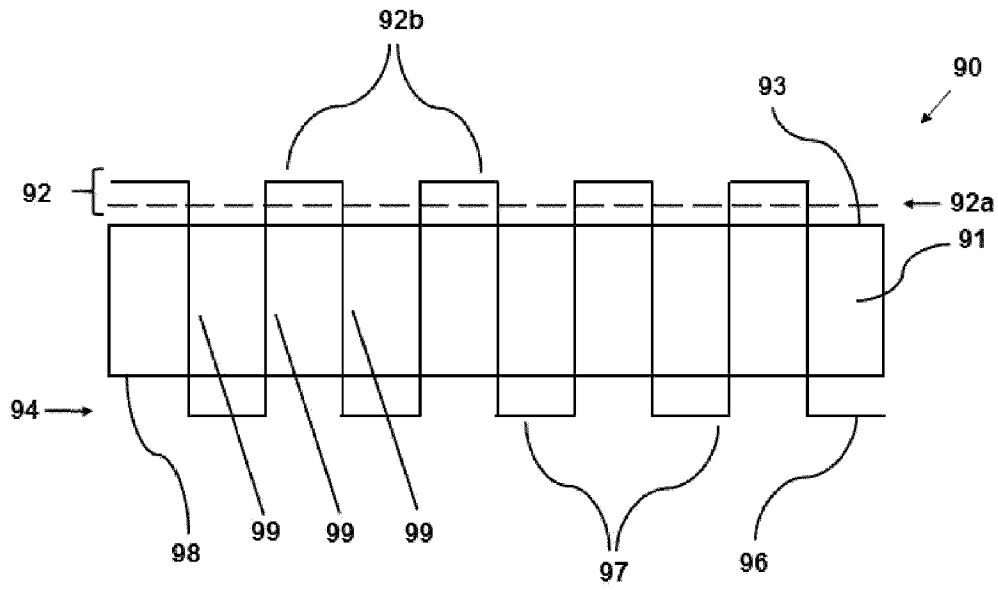

Fig. 10

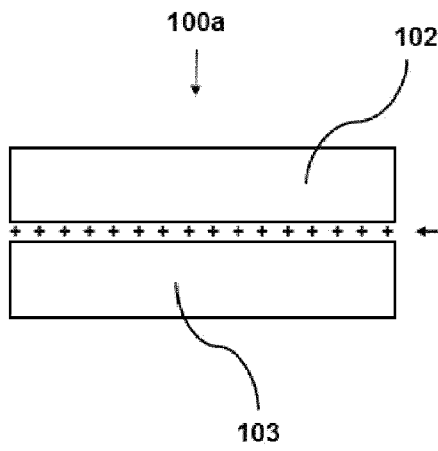

Fig. 11

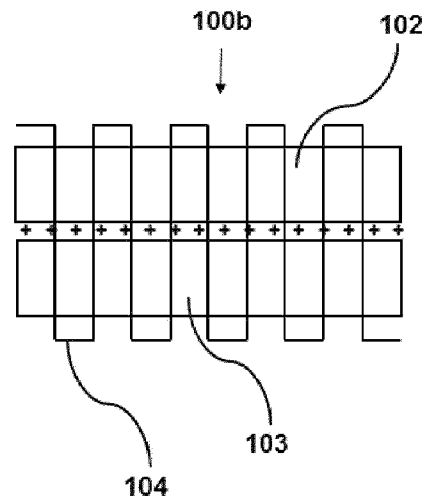

Fig. 12

