



US00D725715S

(12) **United States Design Patent**
Goitein

(10) **Patent No.:** **US D725,715 S**

(45) **Date of Patent:** **** Mar. 31, 2015**

(54) **POWER UNIT ATTACHABLE TO A FOLDED PAPER AIRPLANE**

(71) Applicant: **Shai Goitein**, Pardes Hana (IL)

(72) Inventor: **Shai Goitein**, Pardes Hana (IL)

(**) Term: **14 Years**

(21) Appl. No.: **29/480,697**

(22) Filed: **Jan. 28, 2014**

(51) **LOC (10) Cl.** **21-01**

(52) **U.S. Cl.**

USPC **D21/453**; D21/449

(58) **Field of Classification Search**

CPC A63H 29/00; A63H 29/22; A63H 27/00;
A63H 27/02; A63H 27/04; A63H 27/24;
H01M 2/10

USPC D21/436, 445, 446, 447, 448, 449, 450,
D21/453; 446/31, 57, 58, 59, 60, 61, 62, 66,
446/67, 68, 93, 232; 244/51, 52; 416/20 R;
185/39

See application file for complete search history.

(56) **References Cited**

U.S. PATENT DOCUMENTS

1,035,017	A *	8/1912	Kaiser et al.	446/60
2,715,445	A *	8/1955	Williamson	416/20 R
D214,803	S *	7/1969	Limb	D21/449
3,699,708	A *	10/1972	Mabuchi	446/57
3,757,462	A *	9/1973	Mabuchi	446/58
D241,564	S *	9/1976	Kabchef	D21/449
3,985,322	A *	10/1976	Mabuchi et al.	248/554
D245,637	S *	8/1977	Jewett	D21/450
4,180,221	A *	12/1979	Harris	244/13
4,377,051	A *	3/1983	Dulake	446/31
5,525,087	A *	6/1996	Chin-Lin	446/59

6,520,823	B2 *	2/2003	Tian et al.	446/57
6,688,937	B1 *	2/2004	Tsai	446/67
7,331,838	B2 *	2/2008	Shantz	446/57
7,377,832	B2 *	5/2008	Chamberlain	446/57
2003/0197092	A1 *	10/2003	Tian et al.	244/51
2005/0233672	A1 *	10/2005	Shantz	446/232
2008/0125002	A1 *	5/2008	Goitein	446/57
2009/0017714	A1 *	1/2009	DeRennaux et al.	446/93
2009/0229921	A1 *	9/2009	Sink et al.	185/39
2011/0262789	A1 *	10/2011	Tu	429/100

* cited by examiner

Primary Examiner — Martie K Holtje

(74) *Attorney, Agent, or Firm* — Robert W. J. Usher

(57) **CLAIM**

The ornamental design for a power unit attachable to a folded paper airplane, as shown and described.

DESCRIPTION

FIG. 1 is an isometric view from the front, above and one side of a power unit attachable to folded paper airplane showing my new design;

FIG. 2 is an isometric view from the rear, above and the opposite side to FIG. 1;

FIG. 3 is a side elevational view thereof, drawn to a reduced scale with respect to FIGS. 1 and 2;

FIG. 4 is a side elevational view of the side opposite that shown in FIG. 3, also drawn to a reduced scale with respect to FIGS. 1 and 2;

FIG. 5 is a front elevational view of FIG. 1;

FIG. 6 is a rear elevational view of FIG. 1;

FIG. 7 is a top plan view of FIG. 1;

FIG. 8 is a bottom plan view of FIG. 1; and,

FIG. 9 is an isometric view from the front, below and one side of FIG. 1.

1 Claim, 5 Drawing Sheets

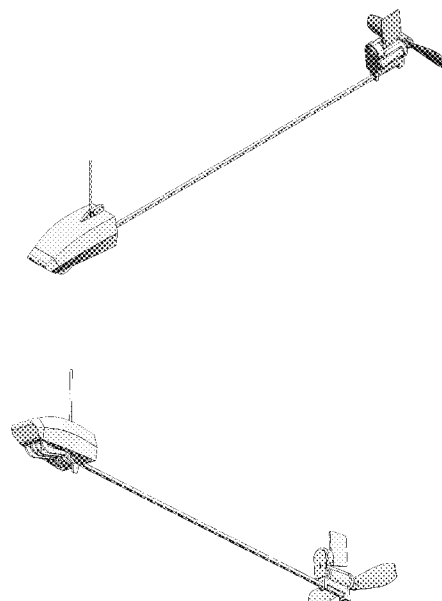

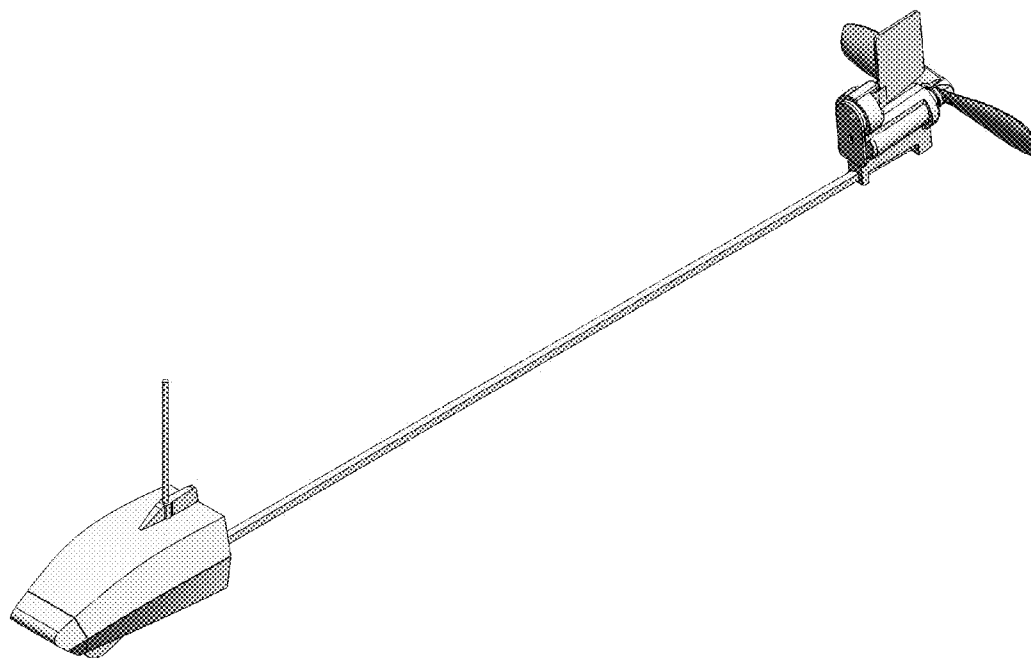

Fig. 1

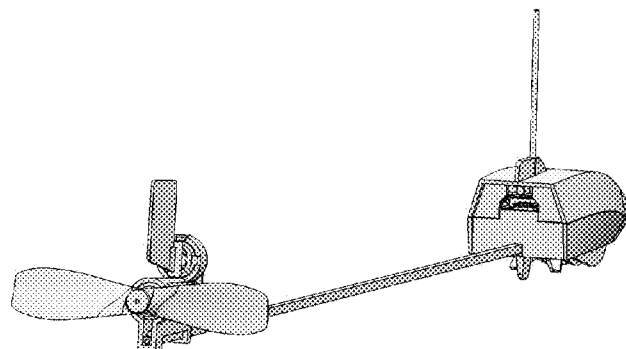

Fig. 2

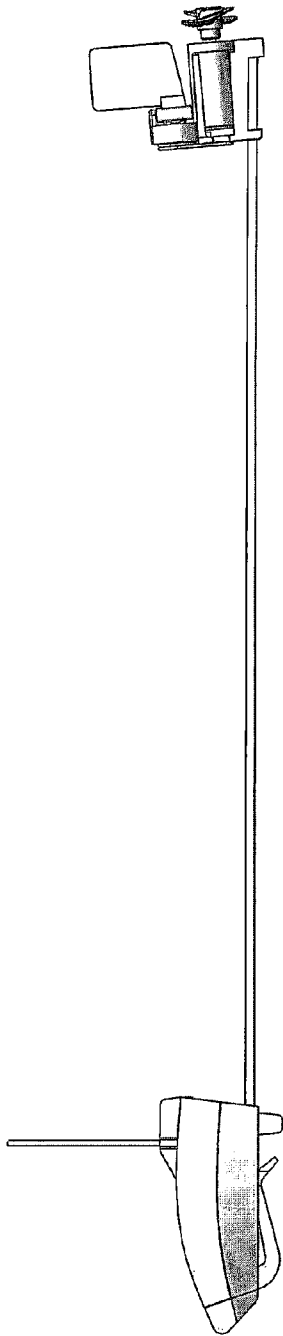

Fig. 3

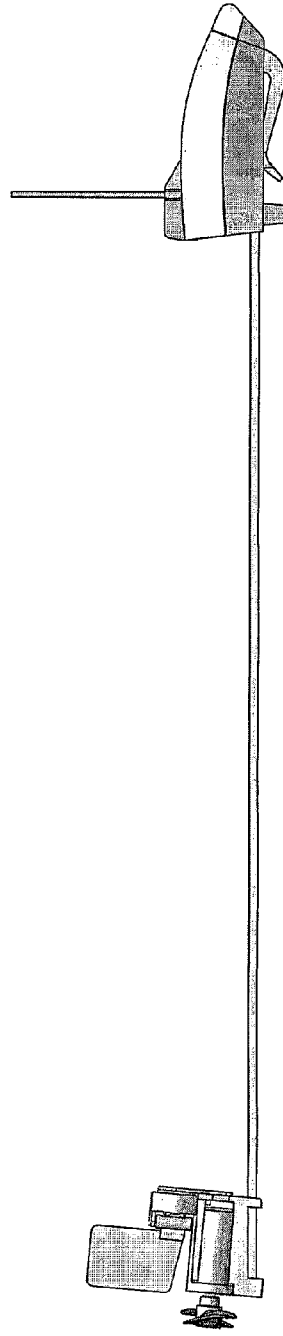

Fig. 4

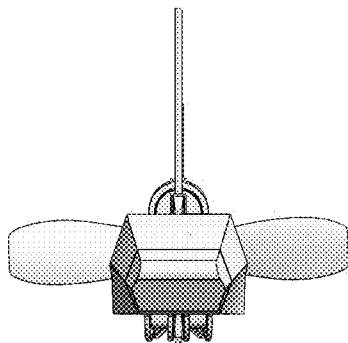

Fig. 5

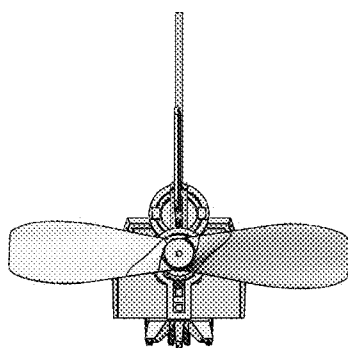

Fig. 6

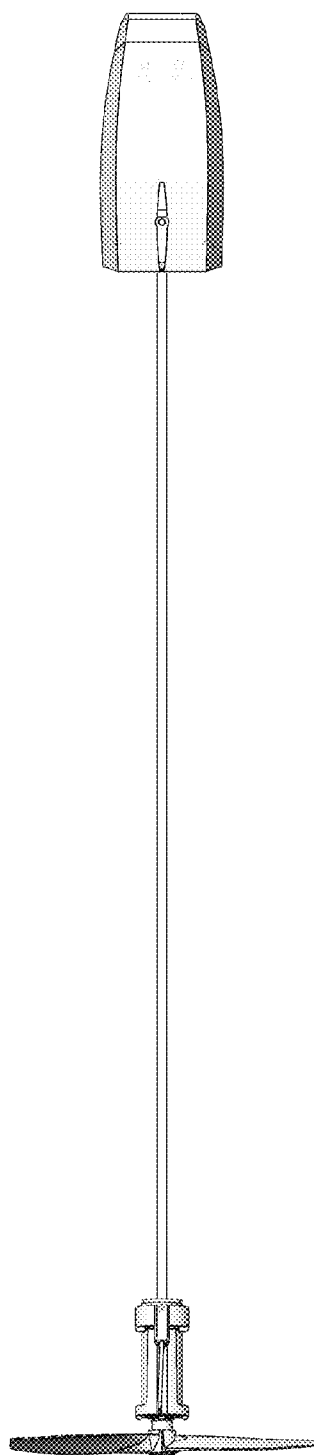

Fig. 7

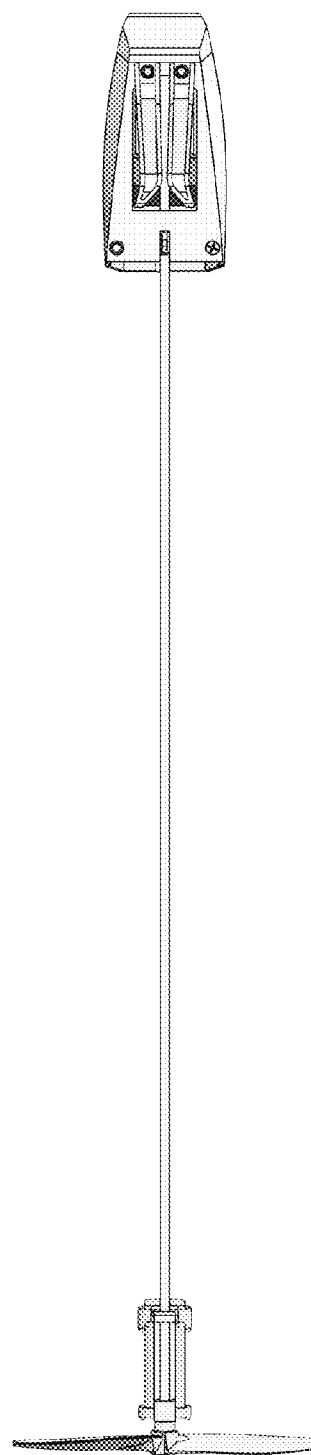

Fig. 8

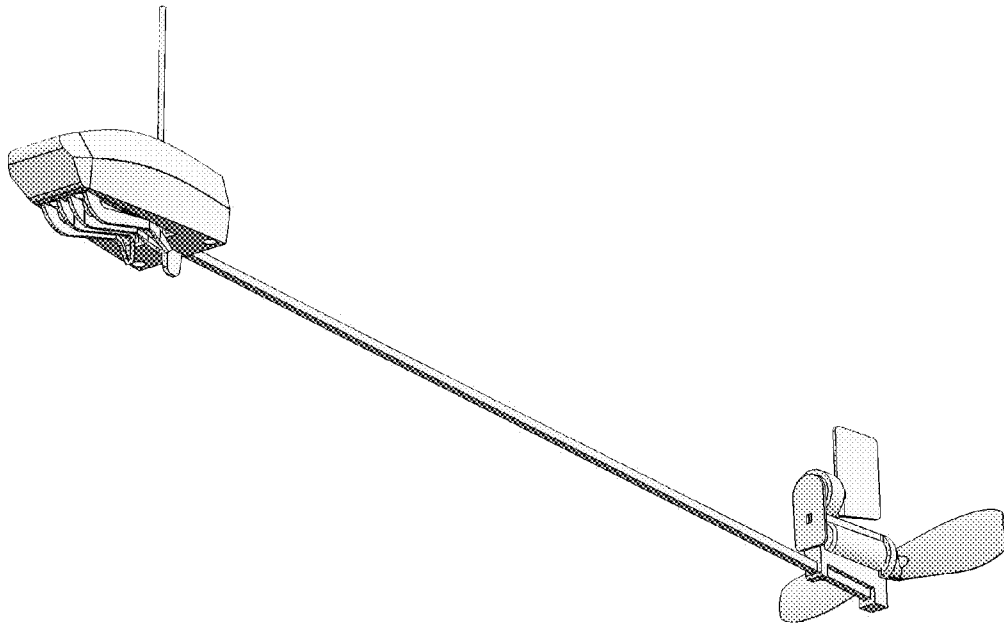

Fig. 9