

Oct. 3, 1939.

R. L. DAVISON

2,175,146

INTERCONNECTING UNIT CONSTRUCTION FOR COMBINED MOLDING AND WIRING SYSTEMS

Filed May 11, 1934

2 Sheets-Sheet 2

Fig. 7.

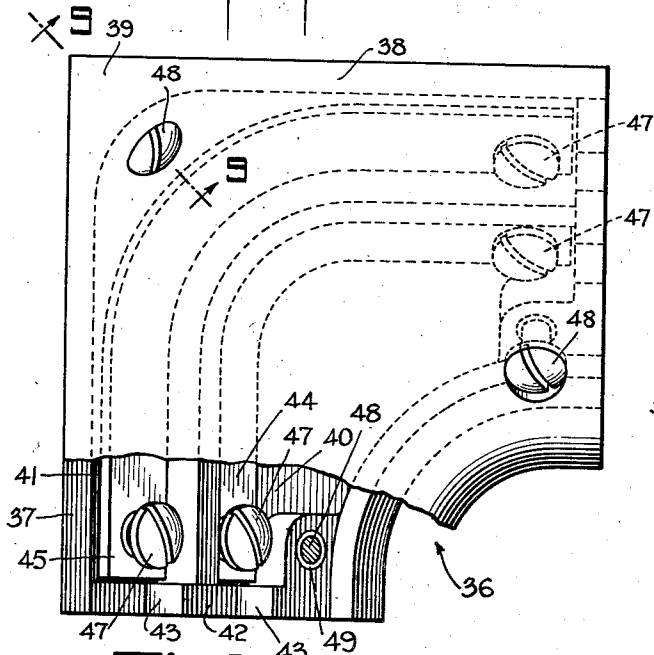

Fig. 8.

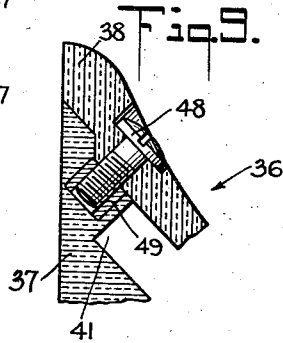

Fig. 9.

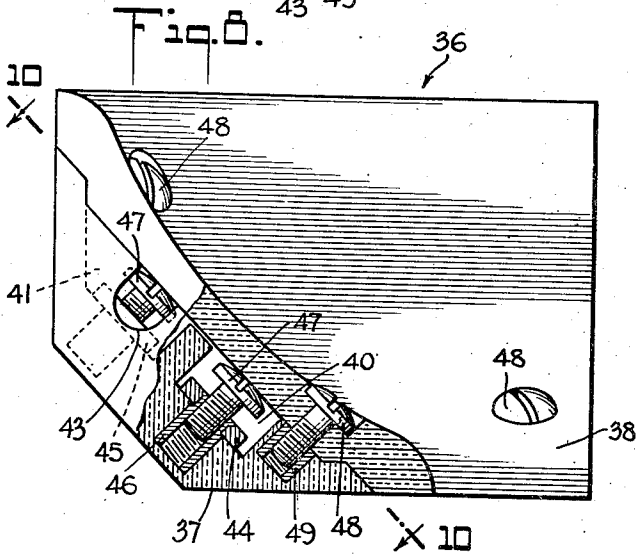
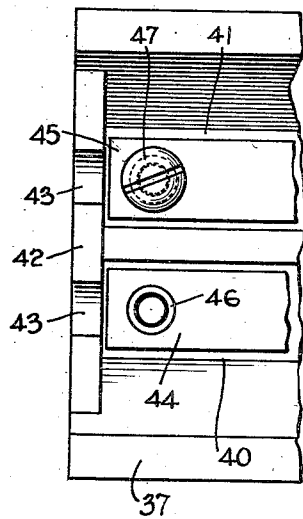

Fig. 10.



INVENTOR
Robert L. Davison
BY
Henry J. Lucke
HIS ATTORNEY

UNITED STATES PATENT OFFICE

2,175,146

INTERCONNECTING UNIT CONSTRUCTION FOR COMBINED MOLDING AND WIRING SYSTEMS

Robert L. Davison, New York, N. Y., assignor to
John B. Pierce Foundation, New York, N. Y., a
corporation of New York

Application May 11, 1934, Serial No. 725,063

6 Claims. (Cl. 173—334.1)

This invention relates to interconnecting unit construction of combined molding and electrical wiring systems.

In my copending applications, Serial No. 682,-
757 and Serial No. 690,653, there is set forth an
exemplification of an improved wiring system
comprised essentially of long and short units of
insulating material and simulating molding in
form and appearance, hollow electrical conduc-
tors, such as tubes, being embedded in and ex-
tending longitudinally of the long units. Com-
bined with these long units are short units for
interconnecting the same, the short units being
disclosed in the aforesaid copending application,
as provided with rods or rod-like conductors, the
terminals of the same projecting at both ends
and beyond the ends of the short unit. In the
long units, the tubular conductors do not pro-
ject at either end of each unit, and preferably
may be flush therewith. An advantage of such
construction is that each long unit permits the
manufacture of the same in standard lengths,
and enables any desired length for individual
installations to be obtained by the mere sawing
or cutting of a standard length to the desired
individual length.

The present invention seeks the securement of
the terminals of the short unit interiorly, i. e.
telescopically relative to the associated tubular
conductors embedded in the long lengths by
means of a terminal element or elements having
one end provided with serrations, the body of
such serrated portion being preferably also tapered
and provided with longitudinal grooves or
flutes on its periphery, resulting in what might
be termed a mutilated screw or a tap. Each ele-
ment is also provided with settable means for
attachment to the conductors extending through
the short unit, the conventional forked or
U-shaped terminal, or other suitable connection
means on one end of the terminal element af-
fording electrical engagement and mechanical
connection to such conductors to be had by means
of a set-screw.

In developing my invention as an element in
an electric current distributing system, the var-
ious conditions arising in installation problems
require a plurality of different kinds of short
units. Practically every condition arising may be
met with a minimum of three different kinds of
short units; a straight unit for association with
the adjacent spaced ends of two long units; an
inside angle short member; and an outside angle
short member. Other kinds of short units may
be advantageously employed, but are not essential.

In my present application I have illustrated a
straight short unit and an inside angle short unit.
The construction of the outside angle short unit,
except for the turn of the angle, is the same as
the construction of the inside angle short unit,
and hence but one of these units will be illus-
trated and described.

The embodiment of the aforesaid principal fea-
ture of this invention also results in a construc-
tion of an electrical device possessing other
advantages, as will be hereinafter more fully ex-
plained in the detailed description of one embodi-
ment of my invention.

Further features and objects of the invention
will be more fully understood from the following
detail description and the accompanying draw-
ings, in which,

Fig. 1 is a top plan view of a preferred form
of short unit construction, the cover or upper
portion of the same being removed to expose
otherwise hidden parts; Fig. 1 also shows in plan
long units associated with the short unit at either
end, the left-hand unit being broken away for
clarity;

Fig. 2 is a bottom plan view of the cover or
top portion of the short unit;

Fig. 3 is an end elevation of the short unit,
the cover or upper portion of Fig. 2 being assem-
bled with the body or bottom portion shown in
Fig. 1;

Fig. 4 is a vertical sectional elevation, on an
enlarged scale, on line 4—4 in Fig. 1;

Fig. 5 is a sectional elevation, also on an en-
larged scale on line 5—5 of Fig. 1;

Fig. 6 is a perspective view of one terminal
element of the short unit;

Fig. 7 is a plan view, partly in section, of an
inside angle short unit embodying my invention;

Fig. 8 is an end elevation, partly in section, of
the unit shown in Fig. 7;

Fig. 9 is a section on the line 9—9 of Fig. 7;
and,

Fig. 10 is a fragmentary plan view of the base,
looking in the direction of the arrows on line
10—10 of Fig. 8.

Fig. 1 illustrates the manner in which my pres-
ent invention is assembled with and between two
long units, such as the units described and
claimed in my copending application above re-
ferred to. These long units are designated by
the reference numeral 10, and embedded therein
and extending longitudinally thereof is a pair of
tubular conductors 11, of copper or other suit-
able conducting material, such conductors being
arranged parallel to or spaced apart from each

other, as shown in the drawings. The ends of the tubular conductors 11 terminate preferably flush with the ends of the long units 10. As shown, the long units 10 are spaced apart from each other and the intervening space between such units is to be occupied by a short unit 12 embodying my present invention.

This short unit consists of a base block 12a, having a cover plate 13 mounted thereon, and such base block 12a and cover 13, respectively, when assembled together as a unit as shown in Figs. 3, 4 and 5, has a cross sectional area similar and equal to the cross sectional area of the long units 10, so that when the short unit embodying my invention is placed in the space between two adjacent long units 10, the continuity of the molding produced thereby is unbroken.

Arranged on the face of the base 12a are the conducting bars or strips 14, these bars 14 being arranged spaced apart and substantially parallel to each other. The ends of the bars 14 terminate at a point within the ends of the base 12a. Secured to the under face of the ends of the bars 14 are anchoring posts 15, such securement being obtained by staking, or in any other desired manner. Recesses 16 are formed in the body of the base 12a and in which the anchoring posts 15 are housed, as clearly shown in Fig. 4. Each anchoring post 15 is drilled and tapped to receive a binding or set screw 17, which serves to securely fasten one end of a terminal connector 18 to the ends of the bars 14.

The terminal connector 18 is illustrated in perspective in Fig. 6, and is shown in operative relation with respect to the conducting bars 14 and tubular conductors 11, in Fig. 1. Referring to such Figs. 1 and 6, the terminal connector 18 is formed of a substantially cylindrical body 19 provided with a plurality of serrations thereon, i. e. in the form of a screw thread, one end 20 of the body 19 is frusto-conical in shape to facilitate the entrance of the cylindrical body 19 into the end of the tubular conductors 11. The cylindrical serrated or threaded body 19 of the terminal connector 18 is provided with longitudinal grooves or flutes 21. The terminal connector 18 is made of relatively hard metal, as phosphor bronze, and its construction is such that it acts as a tap, readily forcing its way into the end of the tubular conductors 11. The external diameter of the threaded body 19 of the terminal connector 18 is greater than the internal diameter of the tubular conductors 11. At the end of the cylindrical body 19, remote from the frusto-conical part 20, is formed integral therewith a flat member 22, provided with a U-shaped slot 23, and which slot partially encircles the body of the binding or set screw 17, under the head of such binding or set screw. The flat member 22 has been shown provided with a U-shaped slot 23, but obviously, I am not limited to this exact construction, and a perforation may be substituted for the U-shaped slot. The area of the flat member 22 is so proportioned relatively to the upper end of the anchoring post 15 and the under face of the head of the binding or set screw 17, that the maximum contact area is obtained.

The threaded or serrated and longitudinally fluted body 19 of the terminal connector 18 is readily screwed into the open terminal end of a tubular conductor 11, the tap-like formation of the body 19 insuring a rigid and intimate engagement between the terminal connector and the tubular conductor. The base block 12a, with the conducting bars or strips in position thereon, is

then placed between the adjacent ends of the long units 10—see Fig. 1—the binding or set screws 17 passed through the U-shaped slots 23, or equivalent perforations, into engagement with the anchoring posts 15. The binding or set screws 17 are screwed into the anchoring posts 15 firmly clamping the flat portion 22 to the conducting bars or strips 14 and completing the electrical connection between the ends of the tubular conductors 11 in the adjacent long units 10.

The end faces of the base block 12a are provided with substantially rectangular grooves 24 of a depth substantially equal to the diameter of the cylindrical body 19 of the terminal connectors 18, and through which such cylindrical body 19 may pass (see Fig. 3).

Fitting on the top of the base block 12a is the cover plate 13, provided with countersunk holes 25 through which may pass the securing screws 26. These screws 26 engage with internally threaded sleeves 27 embedded in the material of the base block 12a. Formed integral with the cover plate 13, and on the under face thereof, are longitudinally extending plates or partitions 28, and transversely extending plates or skirts 29. The skirts 29 engage with the top ends of the base block 12a and complete the substantially rectangular grooves 24 in which are located the cylindrical body portions 19 of the terminal connectors 18. The cover plate 13, together with the plates 28 and skirts 29 completely house the various elements mounted on the top of the base block 12a.

When the cover plate 13 is mounted on the base block 12a, in the manner above described, the two members form a connecting link or block of the same shape and cross-sectional area as the long units 10, and therefore, the continuity of the long units 10 appears unbroken.

The short unit 12 may preferably be utilized as the point, at which connection is made from power leads to the tubular conductors 11, or conductors are attached to take power from the tubular conductors 11. The construction of the short unit is such that conducting elements may be readily attached to the tubular conductors 11, through the medium of the conducting bars or strips 14.

The manner in which power leads or other conductors may be connected to the tubular conductors 11 is illustrated in Figs. 1 and 5. Referring to such figures it will be noted that the conducting bars or strips 14 are spaced apart from and arranged parallel to each other. The material of the base block 12a, between the bars or strips 14 is perforated as indicated at 30, and through which may pass, from the bottom of the base block 12a, the individual conductors 31 forming the cable 32. Preferably also the bottom end of the perforations 30 is enlarged as indicated at 33, whereby a chamber is formed in which bending of the cable 32 is facilitated. The number of perforations 30 may be as many as desired within the limits of the short units 12, and I have shown the short unit 12 in the drawings as being provided with two such perforations 30, and therefore two cables 32.

To facilitate the attachment of the individual conductors 31 of the cable 32 to the conducting bars or strips 14, I preferably provide such bars with threaded perforations, in each of which is screwed a binding or set screw 34. The ends of the conductors 31 are clamped between the bar or strip 14 and the binding or set screws 34. To provide space for the end of the binding or set screws 75

34, I form recesses 35, see Fig. 5, in the base block 12a beneath the set screws 34.

The above description pertains to the novel construction of a short unit embodying my invention, where such unit is to be used as an element in a "straight run", where the long and short elements may be placed end to end along one side of a room, or other enclosure. Where an angle occurs in a room, as in a corner, my invention may be employed, but the form thereof differs from that disclosed in Figs. 1 to 5 of the drawings, and described above.

There is shown in Figs. 7, 8, 9 and 10 a form of my invention which may be utilized as the connecting link between adjacent long units 10, where such units meet in the corner of a room, or other enclosure.

As in the form of my invention shown in Figs. 1 to 5 inclusive, the present form, shown in Figs. 7-10 inclusive, comprises a base block, conducting bars or strips mounted thereon, and a cover for the base block enclosing the conducting bars or strips. The specific form of such individual elements is different, the differences being controlled mainly by the situation in which the units are to be used.

Referring to Figs. 7-10 inclusive, 36 designates a short corner unit, comprised of a base block 37 having a cover plate 38 secured thereto. In plan view, one angle of the short corner unit 36, as the angle 39, is a right angle and is adapted to be placed in the corner made by the meeting of a floor and two walls. The end faces of the short corner unit 36 have the form and area of the end faces of the long units 10, and therefore, when my improved short corner unit 36 is assembled with long units 10, the smooth exposed contour of the long units 10 is unbroken in passing over the short corner unit.

In the present modification of my invention, I provide, in the upper face of the base block 37, two arcuate grooves 40 and 41 respectively, such grooves being separated from the end faces of the base block by the partitions 42. These partitions 42 are provided with notches 43 in alignment with the grooves 40 and 41.

Housed within the grooves 40 and 41, are the conducting bars or strips 44 and 45 respectively, such strips being arcuate in form, to conform to the shape of the grooves 40 and 41. At each end of each of the conducting bars or strips 44 and 45 is secured, as by staking, an anchoring post 46. Such posts are housed within depressions formed in the base block 37. Also, such posts are drilled and tapped to receive the binding or set screws 47.

The terminal connectors 18, illustrated in Fig. 6, are screwed into the terminal end of the tubular conductors 11, in the manner heretofore described, and the flat end 22 clamped to the conducting bars or strips 44 and 45 by the binding or set screws 47. The cover plate 38 is held in position on the base block 37 by screws 48 engaging in threaded members 49 embedded in the base block. While in this form of my invention, I may provide means for attaching conductors—other than the tubular conductors 11—to the conducting bars or strips 44 and 45, I prefer not to do so, and therefore have not illustrated means for so doing.

Various other forms and modifications of my invention will readily suggest themselves to those skilled in the art, and therefore I may vary the size, shape, and arrangement of parts comprising my device within relatively wide limits without departing from the spirit of the invention.

I claim:

1. A combined molding and electrical wiring system comprising alternately assembled long and short conductor carrying units composed entirely of insulating material, and adapted to serve as a building molding, hollow electrical conductors insulatedly embodied in each long unit having termini respectively substantially flush at each end of each long unit, said short units serving as couplings for the long units and having electrical conductors insulatedly embodied therein having termini respectively projecting at each end of each short unit and arranged to respectively engage the hollow termini of the conductors of adjacent long units, certain of said short units being provided with outlet means, the exposed faces of said long units and said short units being substantially identical in facial contour to effect visual continuity when assembled, the projecting terminal portions of the electrical conductors of certain of said short units being elements separable from their respective body portions, each element having a generally cylindrical end bearing screw-threaded faces for insertion to effect mechanical and good electrical connection within the hollow terminal portion of an associated hollow conductor, and means for securing each such element in mechanical and good electrical engagement with its body portion.

2. A combined molding and electrical wiring system comprising alternately assembled long and short conductor carrying units composed entirely of insulating material, and adapted to serve as a building molding, hollow electrical conductors insulatedly embodied in each long unit having termini respectively substantially flush at each end of each long unit, said short units serving as couplings for the long units and having electrical conductors insulatedly embodied therein having termini respectively projecting at each end of each short unit and arranged to respectively engage the hollow termini of the conductors of adjacent long units, certain of said short units being provided with outlet means, the exposed faces of said long units and said short units having their lateral edges in rectilinear alignment to effect visual continuity when assembled, the projecting terminal portions of the electrical conductors of certain of said short units being elements separable from their respective body portions, each element having a generally cylindrical end bearing screw-threaded faces for insertion to effect mechanical and good electrical connection within the hollow terminal portion of an associated hollow conductor, and means for securing each such element in mechanical and good electrical engagement with its body portion.

3. A combined molding and electrical wiring system comprising alternately assembled long and short conductor carrying units composed entirely of insulating material, and adapted to serve as a building molding, said short units serving as couplings for the long units, the conductors of said long units and said short units being in continuous conductive relationship when the units are assembled end to end, the insulation within the body of each long unit and each short unit wholly embracing the respective conductors of such unit and integrally extending from conductor to conductor of such unit, the exposed faces of said long units and said short units having their lateral edges in rectilinear alignment to effect visual continuity when assembled, one of said short units being provided with an opening at an unexposed face to afford access to the respective conductors of such unit for effecting

electrical connection with the service lines, the projecting terminal portions of the electrical conductors of certain of said short units being elements separable from their respective body portions, each element having a generally cylindrical end bearing screw-threaded faces for insertion to effect mechanical and good electrical connection within the hollow terminal portion of an associated hollow conductor, and means for securing each such element in mechanical and good electrical engagement with its body portion.

4. A combined molding and electrical wiring system comprising alternately assembled long and short conductor carrying units composed entirely of insulating material, and adapted to serve as a building molding, hollow electrical conductors insulatedly embodied in each long unit having termini respectively substantially flush at each end of each long unit, said short units serving as couplings for the long units and having electrical conductors insulatedly embodied therein having termini respectively projecting at each end of each short unit and arranged to respectively engage the hollow termini of the conductors of adjacent long units, certain of said short units being provided with outlet means, the exposed faces of said long units and said short units being substantially identical in facial contour to effect visual continuity when assembled, the projecting terminal portions of the electrical conductors of certain of said short units being elements separable from their respective body portions, each element having a generally cylindrical end bearing screw-threaded faces for insertion to effect mechanical and good electrical connection within the hollow terminal portion of an associated hollow conductor, and means for securing each such element in mechanical and good electrical engagement with its body portion, the body of said certain short units being of separable parts to afford access to said element securing means.

5. A combined molding and electrical wiring system comprising alternately assembled long and short conductor carrying units composed entirely of insulating material, and adapted to serve as a building molding, hollow electrical conductors insulatedly embodied in each long unit having termini respectively substantially flush at each end of each long unit, said short units serving as couplings for the long units and having electrical conductors insulatedly embodied therein having termini respectively projecting at each end of each short unit and arranged to respec-

tively engage the hollow termini of the conductors of adjacent long units, certain of said short units being provided with outlet means, the exposed faces of said long units and said short units having their lateral edges in rectilinear alignment to effect visual continuity when assembled, the projecting terminal portions of the electrical conductors of certain of said short units being elements separable from their respective body portions, each element having a generally cylindrical end bearing screw-threaded faces for insertion to effect mechanical and good electrical connection within the hollow terminal portion of an associated hollow conductor, and means for securing each such element in mechanical and good electrical engagement with its body portion, the body of said certain short units being of separable parts to afford access to said element securing means.

6. A combined molding and electrical wiring system comprising alternately assembled long and short conductor carrying units composed entirely of insulating material, and adapted to serve as a building molding, said short units serving as couplings for the long units, the conductors of said long units and said short units being in continuous conductive relationship when the units are assembled end to end, the insulation within the body of each long unit and each short unit wholly embracing the respective conductors of such unit and integrally extending from conductor to conductor of such unit, the exposed faces of said long units and said short units having their lateral edges in rectilinear alignment to effect visual continuity when assembled, one of said short units being provided with an opening at an unexposed face to afford access to the respective conductors of such unit for effecting electrical connection with the service lines, the projecting terminal portions of the electrical conductors of certain of said short units being elements separable from their respective body portions, each element having a generally cylindrical end bearing screw-threaded faces for insertion to effect mechanical and good electrical connection within the hollow terminal portion of an associated hollow conductor, and means for securing each such element in mechanical and good electrical engagement with its body portion, the body of said certain short units being of separable parts to afford access to said element securing means.

ROBERT L. DAVISON.