

June 19, 1923.

1,459,141

S. A. CRONE

RAILWAY BRAKE BEAM

Filed June 12, 1922

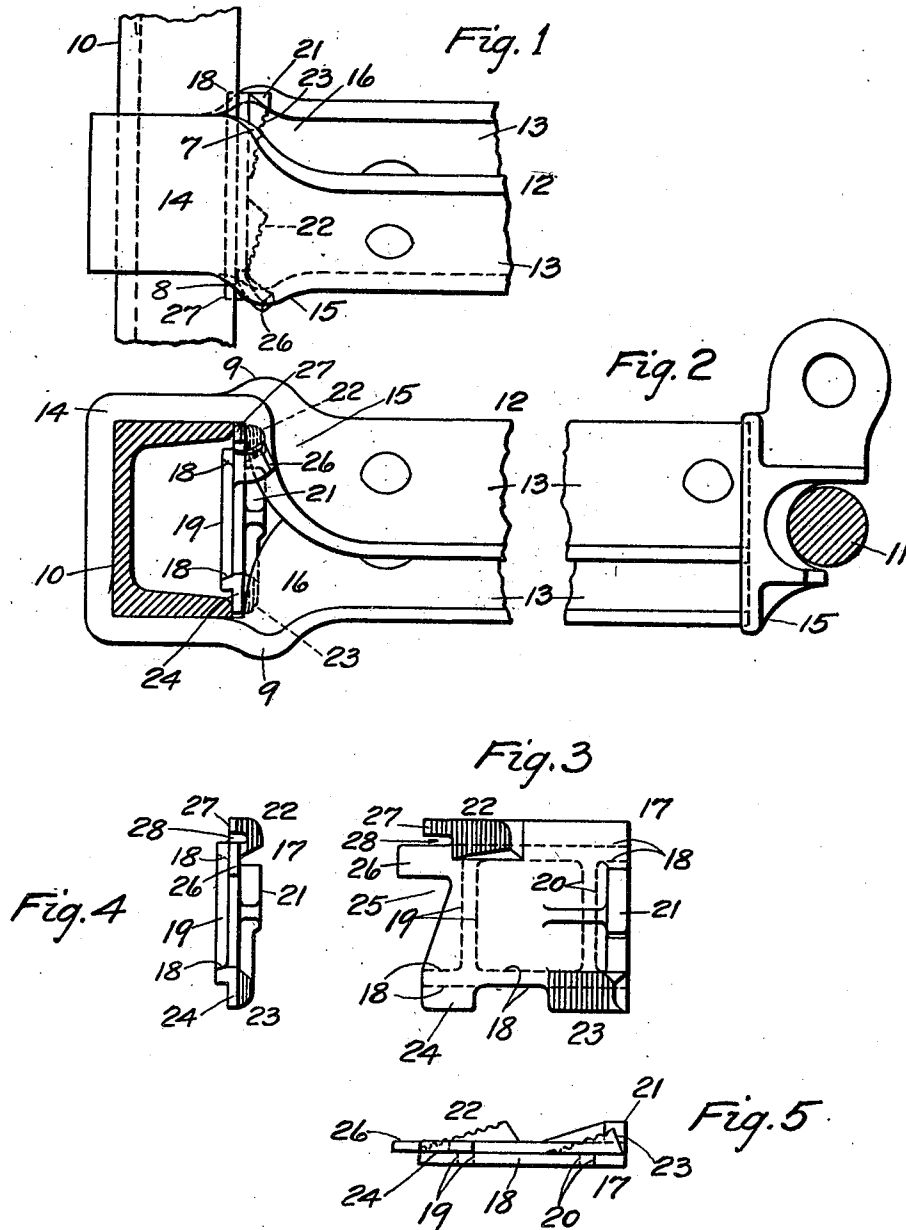

INVENTOR:
Seth A. Crone,
BY
Charles C. Gill,
ATTORNEY.

Patented June 19, 1923.

1,459,141

UNITED STATES PATENT OFFICE.

SETH A. CRONE, OF EAST ORANGE, NEW JERSEY.

RAILWAY BRAKE BEAM.

Application filed June 12, 1922. Serial No. 567,577.

To all whom it may concern:

Be it known that I, SETH A. CRONE, a citizen of the United States, and a resident of East Orange, in the county of Essex and State of New Jersey, have invented certain new and useful Improvements in Railway Brake Beams, of which the following is a specification.

The invention pertains more particularly to trussed-beams for railway cars and especially to novel means for securing the strut to the compression member of the beam.

My invention resides in a novel integral wedge-plate to be driven between the outer edges of the flanges of the compression member and the adjacent surfaces of the strut, said wedge-plate having toothed surfaces to intimately engage the adjacent surfaces of the strut and a projecting tongue to be bent or deflected against an edge of the strut for aiding in the locking of the wedge-plate in fixed position, and said wedge-plate being of otherwise special and also durable construction adapting the same to be driven in a direct line to position by means of hammer-blows applied against one end thereof and to resist buckling or other distortion under the force required for correctly positioning the plate between the edges of the compression member and the adjacent shoulders on the strut.

The present invention comprises certain improvements on the brake-beam disclosed in Letters Patent of the United States No. 1,387,768, granted to me on August 16, 1921, and said invention will be fully understood from the detailed description hereinafter presented, reference being had to the accompanying drawings, in which:

Fig. 1 is a plan view of a portion of a brake-beam equipped with a strut and securing means embodying my invention;

Fig. 2 is a side elevation, partly broken away, of a truss-beam embodying the invention, as in Fig. 1, the compression member and truss rod being shown in cross section;

Fig. 3 is an outer face view of the wedge-plate employed by me for binding the strut and compression member in firm relation to each other;

Fig. 4 is an end projection of the same taken from the left hand side of Fig. 3, and

Fig. 5 is an edge projection of the same taken from the lower edge of Fig. 3.

In the drawings, 10 designates a channel-shaped compression member of a brake-beam, 11 the truss-rod and 12 the strut, which may be made from a bar of forged metal forming the two integral sides 13 to receive between them, as usual, the brake-lever, not shown, and providing at its folded middle portion a yoke or loop 14 which extends transversely upon and closely receives the channel member 10, which may be of any approved cross-section. At their front ends the sides 13 have secured thereto a cap 15 to receive the middle portion of the usual truss-rod or tension member 11. The deflected or angularly disposed sides 13 and yoke or loop 14 of the strut are of familiar construction and design, and hence require no specific description. The deflection of the sides 13 results in said sides adjacent to the beam 10 having an angular relation to said beam and in diagonally opposite portions 15, 16, respectively, of said sides being brought inwardly within the horizontal planes of and opposite to the edge surfaces of the upper and lower flanges of said beam, and it is at these two diagonally opposite portions at which, by means of my invention, I interlock the strut and compression member together with binding effect.

The means employed by me for securing the strut and compression member in fixed relation to each other consists of a wedge-plate 17 shown in detail in Figs. 3, 4 and 5 and in operative position in Figs. 1 and 2. The wedge-plate 17 has a width equal to the width of the compression member 10, and on one face is formed integrally with guiding ribs 18 to enter between the flanges of the beam 10, as shown in Fig. 2, said ribs being indicated by dotted lines in Fig. 3 and connected back of the forward end of the plate by a transverse rib 19 and adjacent to the rear end of said plate by a transverse rib 20, which ribs 19, 20 add strength to the wedge-plate and aid in preventing the buckling thereof during the time the wedge is driven to position between the strut and the compression member. On its outer or obverse face the plate 17 is formed at its back end with a shoulder 21 which will receive the blows of the hammer employed in driving the wedge to position, and on said obverse face of the wedge-plate 17 and at opposite sides thereof are integrally formed wedges 22, 23, said wedges being on planes offset from each other, with the wedge 22 set in

advance of the wedge 23, and both of said wedges being transversely grooved or serrated, as shown.

At the forward end of the plate 17 and at one side edge portion thereof, is formed a lateral extension or wing 24 which is in advance of the wedge 23 and extends outwardly beyond the adjacent guiding rib 18, so that as the plate 17 is being driven to operative position said extension or wing 24 may ride on and have a bearing against the outer edge of one flange of the beam 10, while said adjacent rib 18 lies at the inner face of said flange, as shown in Fig. 2. The extension or wing 24 is not shown in my aforesaid patent and is an important feature of the present wedge-plate. The extension or wing 24 aids in strengthening and guiding the plate 17 along a direct path and serves as a pilot for the wedge 23.

The plate 17 at its forward portion, aside from the presence of the lateral extension or wing 24, is of special construction, being recessed inwardly near one side thereof, as at 25, and formed at said side with a forwardly projecting tongue 26 which is of about the same thickness as the body of the plate and at its inner side edge defines one edge of said recess 25. The outer edge of the tongue 26 is in line with the outer longitudinal edge of the adjacent rib 18, as shown in Fig. 3, and hence said tongue 26 is backed at its rear end by the said rib 18 and the rib 19. The wedge 22 is formed on the body of the plate 17, the forward end thereof being on about the transverse plane of the forward edge of the wing 24 and adjacent portion of the body of the plate. The wedge 22 inclines downwardly and forwardly and at the outer side of its forward portion is of reduced width or in the form of a tongue 27, which is spaced outwardly, by a recess 28, from the outer side edge of the tongue 26. The tongue 26 projects forwardly beyond the body of the plate 17 and the recesses 25, 28 set backwardly into said body, result in the tongue 26 being of adequate length and in proper position to be bent over against one side edge of one member of the strut, as shown in Figs. 1 and 2, for locking the wedge plate in operative position and against accidental displacement or becoming lost.

In the employment of my invention I do not modify the construction of the compression member 10 or of the strut 12, but make use of the wedge plate 17 as the means for locking the strut and compression member together, and in carrying out this feature of the invention I apply the reverse face of the plate 17 against the edges of the flanges of the beam 10, the ribs 18 being disposed between said flanges, as shown in Fig. 2, and, by means of a hammer directed against the shoulder 21 and adjacent portions of the

plate, drive the plate between the diagonally disposed portions of the strut and the adjacent edges of the beam 10, the action of the plate 17 on being driven home, being to tightly bind the loop or yoke 14 against the compression member, no further means for connecting the strut and beam 10 being required, and thereafter by means of a hammer I bend the tongue 26 over against one edge of a side member 13 of the strut, as shown in Figs. 1 and 2, and thereby lock the wedge plate in operative position and against accidental displacement or becoming lost. The wedge 22 at first enters between the strut and compression member more or less freely because at the point of entrance for the wedge 22 the edge 7 of the adjacent side of the strut is substantially free of the compression member 10, while at the opposite edge 8 of the same side of the strut, said edge 8 passes within the horizontal plane of the upper flange of the compression member, as shown at the upper side of Fig. 2, and it is at this portion of the side of the strut that the wedge 22 performs its duty, engaging the upper flange of the compression member and the adjacent surface of the side of the strut 12 and entering into such firm engagement with such side of the strut as to partly mutilate the metal thereof and to such extent that the metal becomes forced into the serrations of the wedge 22. The wedge 23 is offset rearwardly from the plane of the wedge 22 and is, adjacent to the rear portion of the plate, offset downwardly beyond the lower side edge thereof, and this wedge on the application of the plate 17 to position immediately engages the adjacent diagonal portion 16 of its side of the strut 12 since said portion 16 at the point of entrance for the wedge 23 is closely adjacent to the lower flange of the beam 10, so that, looking at Fig. 2, the wedge 23 engages the adjacent diagonal portion 16 of the lower strut member at the entrance point of the wedge between the strut and the compression member, while the wedge 22 engages the edge of the diagonal portion 15 of the upper side of the strut. The sides 13 are set at the diagonally opposite portions 15, 16, as is well-known, due to the twisting of the members of the bars, within the horizontal planes of the flanges of the beam 10, while at their other diagonally opposite portions, as at 9 (Fig. 2), said sides extend outwardly from the horizontal planes of the flanges of said beam, and due to this disposition of the said diagonal portions of the sides of the strut adjacent to the beam 10, I offset the wedges 22, 23 so that both of said wedges, when the plate 17 is being driven home, simultaneously engage those respective portions of the sides 13 of the strut which lie within and are opposed to the horizontal planes of the flanges of the beam. The wedges 22, 23, act

substantially simultaneously and with a corresponding operation, as they are intended to do, in binding the strut and compression member in fixed relation to each other, and the plate 17 is of strong construction permitting it to be driven home with the blows of a hammer applied against the end of the same, so that there may be no doubt as to the efficiency of the wedges 22, 23 in the performance of their duties.

The serrations on the wedges 22, 23 aid in securing an interlocking of the wedges with the adjacent portions of the strut and in preventing any loosening of the plate 17 due to the jars to which brake mechanisms are usually subjected. The plate 17 becomes securely held at the faces of the wedges 22, 23 and also by the lateral pressure exerted against said wedges by the strut and by the pressure with which the plate is bound against the compression member 10, and as further means for locking the plate 17 in fixed operative position and against accidental displacement I, as aforesaid, bend the tongue 26 firmly against the adjacent side edge of the upper strut member, as shown in Figs. 1 and 2.

What I claim as my invention and desire to secure by Letters-Patent, is:

1. In a brake-beam, a flanged compression member, a strut encompassing said member and deflected angularly adjacent to the flanges thereof to form angularly disposed parallel sides for the brake lever, and a securing plate driven between said flanges and the adjacent angular portions of the strut and having on diagonally opposite portions of one face thereof wedges, one being in advance of the other, engaging the diagonally opposite inwardly turned portions of the strut, and said plate also having adjacent to one side of its forward end a forwardly projecting tongue to be bent over against the adjacent edge of the strut for locking said plate against accidental displacement.

2. In a brake-beam, a flanged compression member, a strut encompassing said member and deflected angularly adjacent to the flanges thereof to form angularly disposed parallel sides for the brake lever, and a securing plate driven between said flanges and the adjacent angular portions of the strut and having on diagonally opposite portions of one face thereof wedges, one being in advance of the other, engaging the diagonally opposite inwardly turned portions of the strut, and said plate also having adjacent to one side of its forward end a forwardly projecting tongue to be bent over against the adjacent edge of the strut for locking said plate against accidental displacement, the forward edge of said plate being recessed inwardly at opposite sides of said tongue.

3. In a brake-beam, a flanged compression member, a strut encompassing said member and deflected angularly adjacent to the flanges thereof to form angularly disposed parallel sides for the brake lever, and a securing plate driven between said flanges and the adjacent angular portions of the strut and having on diagonally opposite portions of one face thereof wedges, one being in advance of the other, engaging the diagonally opposite inwardly turned portions of the strut, and said plate also having at its forward edge adjacent to its forward wedge a forwardly projecting tongue to be bent over against the adjacent edge of the strut for locking said plate against accidental displacement.

4. In a brake-beam, a flanged compression member, a strut encompassing said member and deflected angularly adjacent to the flanges thereof to form angularly disposed parallel sides for the brake lever, and a securing plate driven between said flanges and the adjacent angular portions of the strut and having on diagonally opposite portions of one face thereof wedges, one being in advance of the other, engaging the diagonally opposite inwardly turned portions of the strut, and said plate also having at its forward edge adjacent to its forward wedge a forwardly projecting tongue to be bent over against the adjacent edge of the strut for locking said plate against accidental displacement, the forward edge of said plate being recessed inwardly at opposite sides of said tongue and the outer recess being extended into the said forward wedge, leaving said wedge with a forwardly projecting tongue.

5. In a brake-beam, a flanged compression member, a strut encompassing said member and deflected angularly adjacent to the flanges thereof to form angularly disposed parallel sides for the brake lever, and a securing plate driven between said flanges and the adjacent angular portions of the strut and having on diagonally opposite portions of one face thereof wedges, one being in advance of the other, engaging the diagonally opposite inwardly turned portions of the strut, and said plate also having at its forward edge adjacent to its forward wedge a forwardly projecting tongue to be bent over against the adjacent edge of the strut for locking said plate against accidental displacement, and said plate having at its forward edge opposite to said tongue, a laterally extending wing to engage one flange of the compression member and being in line with and in advance of the rear wedge.

Signed at New York city, in the county of New York and State of New York, this 9th day of June, A. D. 1922.

SETH A. CRONE.