

(19)



Europäisches Patentamt
European Patent Office
Office européen des brevets



(11)

EP 0 881 365 A3

(12)

EUROPEAN PATENT APPLICATION

(88) Date of publication A3:
09.06.1999 Bulletin 1999/23

(51) Int Cl.6: F01M 1/02, F02F 7/00

(43) Date of publication A2:
02.12.1998 Bulletin 1998/49

(21) Application number: 98830316.0

(22) Date of filing: 21.05.1998

(84) Designated Contracting States:
AT BE CH CY DE DK ES FI FR GB GR IE IT LI LU
MC NL PT SE
Designated Extension States:
AL LT LV MK RO SI

(72) Inventors:
• Ferioli, Vilmo
44042 Cento (Ferrara) (IT)
• Mingozi, Mario
40017 San Giovanni in Persiceto(Bologna) (IT)

(30) Priority: 30.05.1997 IT BO970326

(74) Representative: Lanzoni, Luciano
c/o BUGNION S.p.A.
Via Goito, 18
40126 Bologna (IT)

(71) Applicant: VM MOTORI S.P.A.
I-44042 Cento (Ferrara) (IT)

(54) An engine structure for internal combustion engines

(57) A structure for an internal combustion engine comprises an engine block (1), a crankshaft (2), auxiliary means comprising means (9) for creating suction and means (15) for distributing lubricating fluid under pressure. The crankshaft (2) has keyed to it a first gear wheel (3) consisting of cup gear that meshes with a second gear wheel (6) which directly drives the means (9) for creating suction and with a third gear wheel (13) which drives the means (15) for distributing lubricating fluid under pressure. The engine block (1) also has hollows (10, 16) used to house the auxiliary means (9, 15).

FIG. 1

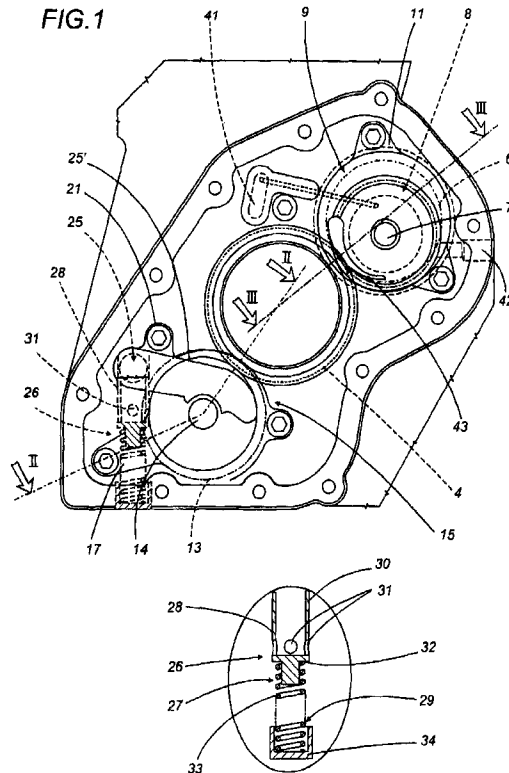

EP 0 881 365 A3



European Patent
Office

EUROPEAN SEARCH REPORT

Application Number
EP 98 83 0316

DOCUMENTS CONSIDERED TO BE RELEVANT			
Category	Citation of document with indication, where appropriate, of relevant passages	Relevant to claim	CLASSIFICATION OF THE APPLICATION (Int.Cl.6)
A	DE 31 42 458 A (LIST HANS) 9 June 1982 * figure 1 * * abstract * * page 6, paragraph 2 * ---	1-4	F01M1/02 F02F7/00
A	EP 0 272 677 A (FIAT AUTO SPA) 29 June 1988 * figure 1 * * abstract * * column 2, line 16 - line 37 * ---	1,5	
A	GB 807 325 A (FIAT) * figure 3 * * page 1, line 71 - line 90 * ---	1-4	
A	PATENT ABSTRACTS OF JAPAN vol. 013, no. 177 (M-818), 26 April 1989 & JP 01 008314 A (AISIN SEIKI CO LTD;OTHERS: 01), 12 January 1989 * abstract * ---	1-5	
A	US 4 586 468 A (DZIOBA DONALD L) 6 May 1986 * figure 1 * * abstract * ---	1-4	TECHNICAL FIELDS SEARCHED (Int.Cl.6) F01M F02F F02B
A	EP 0 305 689 A (PORSCHE AG) 8 March 1989 * figures 1,2 * * abstract * ---	1-4	
A	GB 2 026 612 A (BARMAG BARMER MASCHF) 6 February 1980 * figure 1 * * abstract * -----	1-4	
The present search report has been drawn up for all claims			
Place of search THE HAGUE		Date of completion of the search 15 April 1999	Examiner Wassenaar, G
CATEGORY OF CITED DOCUMENTS X : particularly relevant if taken alone Y : particularly relevant if combined with another document of the same category A : technological background O : non-written disclosure P : intermediate document		T : theory or principle underlying the invention E : earlier patent document, but published on, or after the filing date D : document cited in the application L : document cited for other reasons ----- & : member of the same patent family, corresponding document	

EPO FORM 1503 03/82 (P/04C01)