

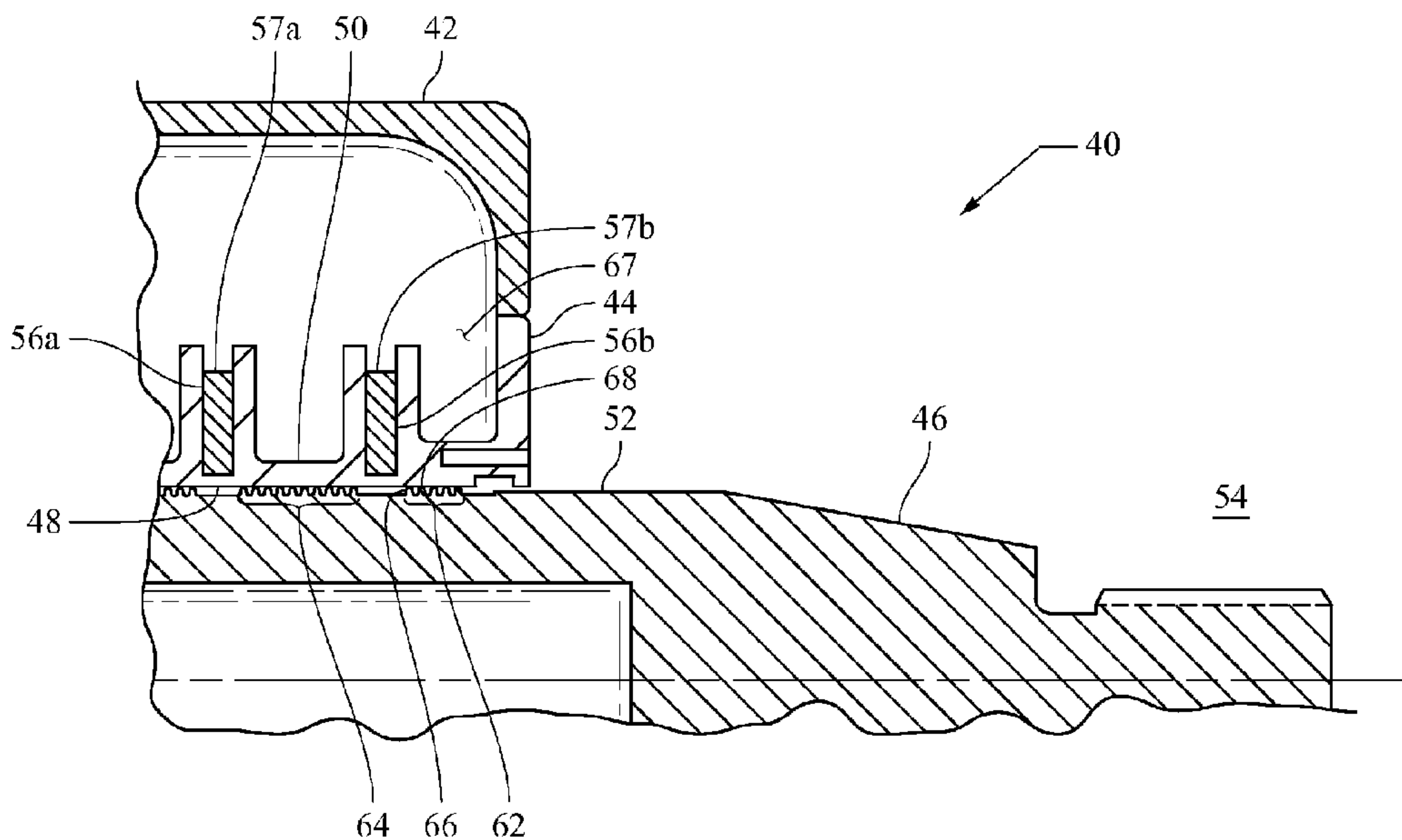

(86) **Date de dépôt PCT/PCT Filing Date:** 2008/10/16
 (87) **Date publication PCT/PCT Publication Date:** 2009/04/23
 (45) **Date de délivrance/Issue Date:** 2016/01/26
 (85) **Entrée phase nationale/National Entry:** 2010/04/19
 (86) **N° demande PCT/PCT Application No.:** US 2008/080157
 (87) **N° publication PCT/PCT Publication No.:** 2009/052282
 (30) **Priorité/Priority:** 2007/10/18 (US60/980,977)

(51) **Cl.Int./Int.Cl. F16J 15/43** (2006.01)
 (72) **Inventeurs/Inventors:**
 MAHONEY, DAVID G., US;
 HELGELAND, WALTER, US
 (73) **Propriétaire/Owner:**
 RIGAKU INNOVATIVE TECHNOLOGIES, INC., US
 (74) **Agent:** MACRAE & CO.

(54) **Titre : JOINT D'ETANCHEITE MAGNETIQUE AVEC COMMANDE PRECISE DU VOLUME DE FLUIDE A CHAQUE STADE D'ETANCHEITE**
 (54) **Title: MAGNETIC FLUID SEAL WITH PRECISE CONTROL OF FLUID VOLUME AT EACH SEAL STAGE**



(57) **Abrégé/Abstract:**

A magnetic fluid seal includes a pole ring having an inner diameter, a rotatable shaft having an outer diameter, the rotatable shaft configured to extend along the inner diameter of the pole ring between an atmosphere side and vacuum side, at least one magnet coupled to the pole ring, the at least one magnet configured to emit a magnetic field having a strength and a shape, and grooves formed on either the inner diameter of the pole ring or the outer diameter of the shaft, the grooves capable of containing ferromagnetic fluid. The ferromagnetic fluid contained the grooves varies so as to improve the performance of the magnetic fluid seal.

(12) INTERNATIONAL APPLICATION PUBLISHED UNDER THE PATENT COOPERATION TREATY (PCT)

(19) World Intellectual Property Organization
International Bureau(43) International Publication Date
23 April 2009 (23.04.2009)

PCT

(10) International Publication Number
WO 2009/052282 A2(51) International Patent Classification:
F16J 15/43 (2006.01)(74) Agent: **LINGL, John, A.**; Brinks Hofer Gilson & Lione,
524 South Main, Suite 200, Ann Arbor, MI 48104 (US).(21) International Application Number:
PCT/US2008/080157(81) Designated States (*unless otherwise indicated, for every kind of national protection available*): AE, AG, AL, AM, AO, AT, AU, AZ, BA, BB, BG, BH, BR, BW, BY, BZ, CA, CH, CN, CO, CR, CU, CZ, DE, DK, DM, DO, DZ, EC, EE, EG, ES, FI, GB, GD, GE, GH, GM, GT, HN, HR, HU, ID, IL, IN, IS, JP, KE, KG, KM, KN, KP, KR, KZ, LA, LC, LK, LR, LS, LT, LU, LY, MA, MD, ME, MG, MK, MN, MW, MX, MY, MZ, NA, NG, NI, NO, NZ, OM, PG, PH, PL, PT, RO, RS, RU, SC, SD, SE, SG, SK, SL, SM, ST, SV, SY, TJ, TM, TN, TR, TT, TZ, UA, UG, US, UZ, VC, VN, ZA, ZM, ZW.

(22) International Filing Date: 16 October 2008 (16.10.2008)

(25) Filing Language: English

(26) Publication Language: English

(30) Priority Data:
60/980,977 18 October 2007 (18.10.2007) US(71) Applicant (*for all designated States except US*): **RIGAKU INNOVATIVE TECHNOLOGIES, INC.** [US/US]; 1900 Taylor Road, Auburn Hills, MI 48326 (US).(84) Designated States (*unless otherwise indicated, for every kind of regional protection available*): ARIPO (BW, GH, GM, KE, LS, MW, MZ, NA, SD, SL, SZ, TZ, UG, ZM, ZW), Eurasian (AM, AZ, BY, KG, KZ, MD, RU, TJ, TM), European (AT, BE, BG, CH, CY, CZ, DE, DK, EE, ES, FI, FR, GB, GR, HR, HU, IE, IS, IT, LT, LU, LV, MC, MT, NL, NO, PL, PT, RO, SE, SI, SK, TR), OAPI (BF, BJ, CF, CG, CI, CM, GA, GN, GQ, GW, ML, MR, NE, SN, TD, TG).

(72) Inventors; and

(75) Inventors/Applicants (*for US only*): **MAHONEY, David, G.** [US/US]; 5 Lafayette Road, Londonderry, NH 03053 (US). **HELGELAND, Walter** [US/US]; 88 Masonic Home Road, Apt. T301, Charlton, MA 01507 (US).**Published:**— *without international search report and to be republished upon receipt of that report*

(54) Title: MAGNETIC FLUID SEAL WITH PRECISE CONTROL OF FLUID VOLUME AT EACH SEAL STAGE

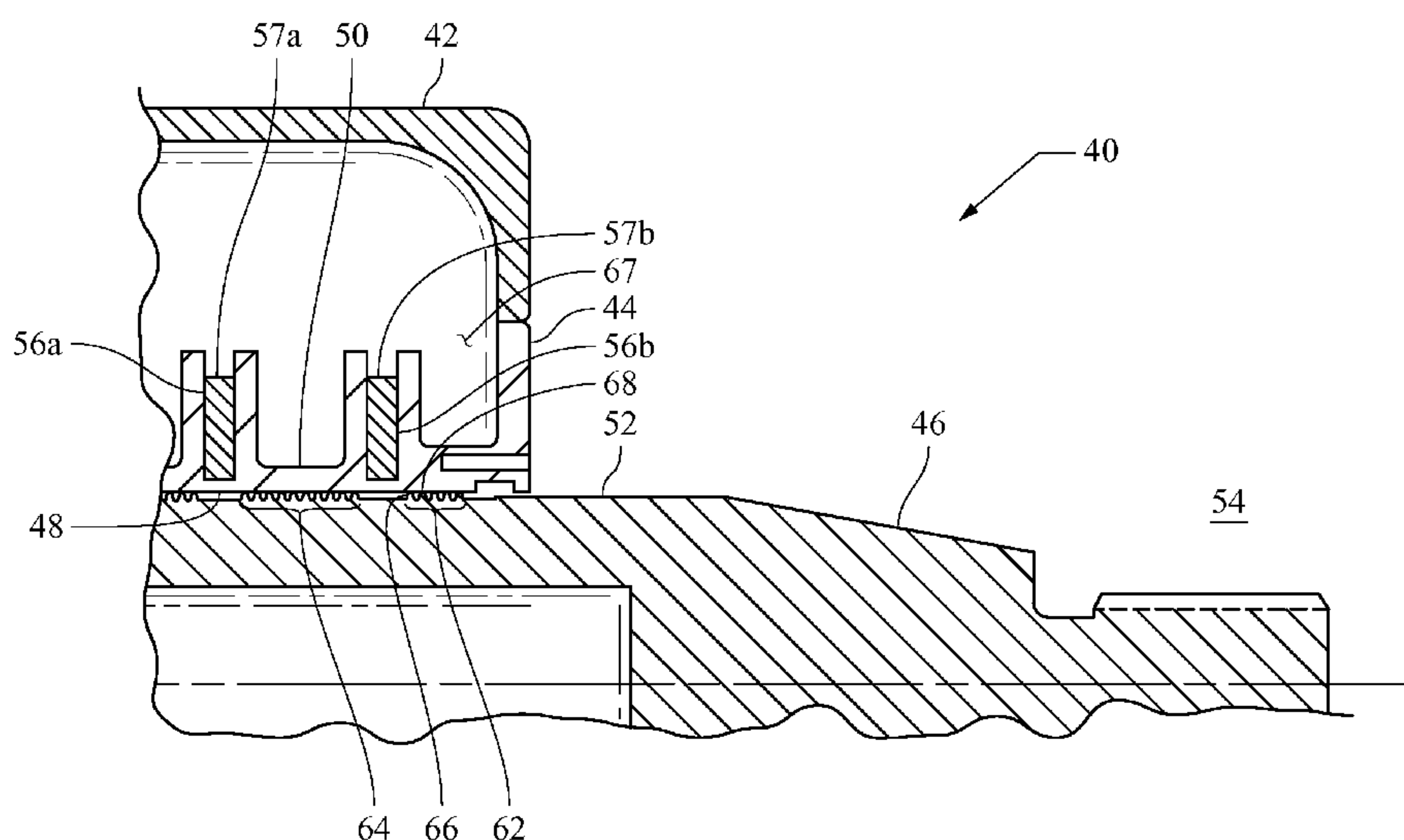

FIG. 3

(57) Abstract: A magnetic fluid seal includes a pole ring having an inner diameter, a rotatable shaft having an outer diameter, the rotatable shaft configured to extend along the inner diameter of the pole ring between an atmosphere side and vacuum side, at least one magnet coupled to the pole ring, the at least one magnet configured to emit a magnetic field having a strength and a shape, and grooves formed on either the inner diameter of the pole ring or the outer diameter of the shaft, the grooves capable of containing ferromagnetic fluid. The ferromagnetic fluid contained the grooves varies so as to improve the performance of the magnetic fluid seal.

WO 2009/052282 A2

MAGNETIC FLUID SEAL WITH PRECISE CONTROL OF FLUID VOLUME AT EACH SEAL STAGE

BACKGROUND OF THE INVENTION

1. Field of the Invention

[0001] The invention relates to magnetic fluid seal systems and methods for making the same.

2. Description of the Known Art

[0002] During operation of magnetic fluid seals, it has been long observed that microbursts of gas emanate from the magnetic fluid seal into the low-pressure vacuum as the rotation of the magnetic fluid seal is started and stopped. This microburst effect, also known as 'burping', results from gas trapped within each seal annulus of the magnetic fluid seal whose pressure exceeds the individual stage gas pressure retention capability. As the rotation of the magnetic fluid seal is started and stopped, the dynamic characteristics of the magnetic fluid seal change slightly, allowing some of the trapped gas to escape into the low-pressure side of the magnetic fluid seal and into the evacuated volume, undesirably raising its overall pressure.

[0003] Additionally, in some applications of magnetic fluid seals, it is acceptable to construct the seal by assembling from an atmosphere side. Other applications impose constraints that require the seal to be assembled from a vacuum side. The latter case tends to impose substantially greater difficulties in controlling the final distribution of fluid within the seal assembly.

BRIEF SUMMARY OF THE INVENTION

[0004] In overcoming the drawbacks of the prior art, a method for making a magnetic fluid seal includes the steps of (1) applying ferromagnetic fluid within at least one of a plurality of grooves formed within a rotatable shaft or a pole ring, (2) freezing the ferromagnetic fluid placed within the at least one of the plurality of grooves, and (3) placing the shaft or the pole ring within an opening of a housing of the magnetic fluid seal before the ferromagnetic fluid unfreezes. It should be understood that the opening of the housing of the magnetic fluid seal can be either an atmosphere side opening or a vacuum side opening, thus allowing the magnetic fluid seal to be assembled from either the vacuum side or the atmosphere side.

[0005] By freezing the ferromagnetic fluid, a precise amount of ferromagnetic fluid can be held in place during assembly of the magnetic fluid seal. As will be explained in the paragraphs that follow, it has been discovered that microbursting can be minimized or even eliminated using this technique. Additionally, it has been discovered that magnetic fluid seals with multiple stages perform better when the amount of ferromagnetic fluid placed with the grooves varies as a function of the strength and shape of a magnetic field. Using the method described in the paragraphs that follow, one can now precisely vary the amount of ferromagnetic fluid placed with the grooves to achieve better performance.

BRIEF DESCRIPTION OF THE DRAWINGS

[0006] Figure 1 illustrates a view of a portion of an embodiment of a magnetic fluid seal embodying the principles of the present invention;

[0007] Figure 2 illustrates a magnified view of a portion of the embodiment of a magnetic fluid seal of Figure 1; and

[0008] Figure 3 illustrates a cut away view of a portion of a second embodiment of a magnetic fluid seal embodying the principles of the present invention.

DETAILED DESCRIPTION OF THE INVENTION

[0009] Referring Figures 1 and 2, a first embodiment of a magnetic fluid seal 10 is shown. Here, a shaft 12 extends between a vacuum side 14 and an atmospheric side 16. A single piece of ferromagnetic stainless steel, e.g., 17-4 PH alloy or 400-series stainless steel alloy is machined into a pole ring 18 with an O-ring sealing grooves 20a and 20b formed on the outside diameter and magnetic pole tips 22 on the inside diameter. The pole tips 22 at the inside diameter of the pole ring 18 are machined as a series of small V-grooves 24 in the inside diameter of the pole ring 18.

[0010] The pole ring 18 is first made with a smooth bore at a carefully controlled diameter. Then large slots 26a and 26b are machined into the inside diameter of the pole ring 18. Then the series of V-grooves 24 are machined to a depth which leaves a small portion of the original inside diameter intact between each pair of adjacent V-grooves. Figure 2 shows two slots 26a and 26b and a plurality of V-grooves 24 in an arrangement which results in pole tips 22 which are left over from the original inside diameter bore. It is in the gap between these pole tips 22 and the shaft 12 that the most intense magnetic field develops, and it is here that the magnetic fluid (represented by "dots" 30 in Figure 2) is retained by magnetic forces.

[0011] The slots 26a and 26b are large enough to accept magnets 32a and 32b, respectively. The slot width is slightly larger than the magnet thickness (e.g.,

2.05 mm slot width for 2.00 mm magnet thickness). This permits easy insertion of magnets 32a and 32b and allows the magnets to move radially and longitudinally within the slots. As more magnets are inserted, the mutually repulsive force serves to position each magnet 32a and 32b equidistant from its neighbors, thereby automatically providing even spacing throughout the magnet layer. Magnets 32a and 32b are added to each slot 26a and 26b until the slot cannot accept any more magnets.

[0012] Typically the magnets 32a and 32b are short cylinders, although they could also be quadrants, sextants, or octants. Rare earth magnets, such as SmCo or NdFeB with high energy products (20 to 35 MGO) are preferred to overcome the losses arising from the inherent shunting effect discussed below. Magnets 32a and 32b are polarized through their thickness (parallel to the shaft axis). Within each magnet slot 26a and 26b the polarity is the same. From one slot to the next, the polarity alternates, so that alternate layers of magnets oppose each other. Any number of magnet layers can be used, but an even number is preferred (for cancellation of fringe fields). One layer is sufficient for all vacuum applications, although two are normally employed. For applications with larger pressure differentials, a greater number of layers can be used. Note that the outer surface of the pole piece 18 is continuous from the atmosphere side to the vacuum side. The continuous outer surface of the pole piece 12 provides a magnetic shunt around each magnet. This dissipates some of the magnetic energy which would otherwise be available to the magnetic circuits which contain the sealing gaps.

[0013] A ferrofluid 22 is provided in the tips 22 and the pole piece 18 is affixed to a housing 34 (having openings 35a and 35b) and the housing 34 affixed to a

flange (not shown) as described in the parent Helgeland reference U.S. Pat. No. 5,826,885. In turn, the flange can be affixed to a suitable fixture disposed between the two atmospheres with the shaft 12 extending therebetween. It should be understood opening 35a is directly adjacent to the atmospheric side 16, while opening 35b is directly adjacent to the vacuum side 14.

[0014] Referring to Figure 3, another embodiment of a magnetic fluid seal 40 is shown. The magnetic fluid seal 40 includes a housing 42, a pole ring 44 and a shaft 46. The pole ring 44 has an inner diameter 48 and an outer diameter 50. The shaft 46 is rotatable and includes an outer diameter 52. The shaft 46 is configured to extend along the inner diameter 48 of the pole ring 44 between an atmosphere side 54 and vacuum side. The vacuum side generally opposes the atmosphere side 54.

[0015] The outer diameter 50 of the pole ring 44 is sized and shaped to include slots 56a and 56b. Magnets 57a and 57b are placed within slots 56a and 56b, respectively. However, it should be understood, as shown in Figure 1, that the slots may be formed on the inner diameter 48 of the pole ring 44.

[0016] The magnets 57a and 57b emit a magnetic field having a size and shape. As will be explained later, this magnet field will function to retain ferromagnetic fluid in place so as to form a seal between the shaft 16 and the pole ring 14.

[0017] The shaft 46 includes at least one seal stage. As can be seen in Figure 1, the seal stage may be part of a first set 62 of seal stages. The first set 32 includes five seal stages. A second set 64 includes ten seal stages. Although this embodiment shows the first set 62 and second set 64 of seal stages formed on the

outer diameter 52 of the shaft 46, it should be understood that the first set 62 and second set 64 of seal stages may be formed on the inner diameter 48 of the pole ring 44, as shown in Figures 1 and 2.

[0018] The seal stage generally includes a "V shaped" groove 66 defining a pole tip 68. Ferromagnetic fluid is placed within each seal stage. When exposed to a magnetic field from the magnets 57a and 57b, it is in the gap between the pole tips 68 and pole ring 44 that the most intense magnetic field develops, and it is here that the ferromagnetic fluid is retained by the magnetic field.

[0019] Additionally, the inventors have discovered that magnetic fluid seals with multiple stages perform better when the amount of ferromagnetic fluid placed within each stage varies as a function of the strength and shape of a magnetic field. The difficulty in varying the ferromagnetic fluid within each stage is that it is difficult to place and hold ferromagnetic fluid in the grooves 66 of each stage when the magnetic fluid seal 40 is manufactured. Using the method described below, which can equally apply to any of the sediments illustrated in Figures 1-3, one can now precisely vary the amount of ferromagnetic fluid placed with the grooves to achieve better performance.

[0020] The method includes the steps of (1) applying ferromagnetic fluid within at least one of a plurality of grooves 66 formed within the shaft 46 (or a pole ring 18 of Figure 1), (2) freezing the ferromagnetic fluid placed within the plurality of grooves 66, and (3) placing the shaft 46 (or a pole ring 18 of Figure 1) within an opening 67 of a housing 42 of the magnetic fluid seal 40 before the ferromagnetic fluid unfreezes. Generally, the ferromagnetic fluid is applied via a syringe like device. Also, it should be understood that the opening of the housing 42 of the magnetic

fluid seal can be either on the atmosphere side 54 or the vacuum side, thus allowing the magnetic fluid seal to be assembled from either the atmosphere side 54 or the vacuum side.

[0021] The method can further include the steps of applying differing amounts of ferromagnetic fluid within the plurality grooves or even applying the ferromagnetic fluid within some of the grooves, while not applying any ferromagnetic fluid in other grooves. Generally, grooves that located closer to the atmosphere side of the magnetic fluid seal are filled with more ferromagnetic fluid as opposed to the grooves located nearer (or even adjacent) to the vacuum side of the magnetic fluid seal 10, which may contain less or even no ferromagnetic fluid (essentially leaving the stage “dry”). Additionally, the amount of ferromagnetic fluid applied to the grooves may vary as a function of the strength and shape of the magnetic field produced by the magnets 57a and 57b, so as to improve performance. This variance based on the strength and shape of the magnetic field can be determined by experimentation and empirical evidence.

[0022] It was mentioned in the background section that during operation of these types of magnetic fluid seals, it has been long observed that micro-bursts of gas emanate from the seal into the low-pressure vacuum as rotation is starts and stops. It has been shown that reducing the pressure of trapped gas within the individual seal stages adjacent to the vacuum side will minimize or eliminate this microbursting effect. It has also been observed that by deliberately creating one or more dry stages closest to the vacuum side, then filling one or more sages immediately adjacent to those dry stages with ferromagnetic fluid in a controlled manner described herein, that some of the ferromagnetic fluid will transfer to the one

or more dry stages. During the transfer process, the gas that is trapped within the effected stage is free to be expand into the vacuum side of the seal and be evacuated by the processing pumps. This leaves very low-pressure gas within the new seal stage and satisfies the condition to prevent microbursting by reducing the pressure behind the newly formed seal stage. This method is very important for systems that are pumped down to very low pressures then sealed off with little or no active pumping to remove the undesirable gas emanating from the microbursting.

[0023] The scope of the claims should not be limited by the preferred embodiments set forth in the examples, but should be given the broadest interpretation consistent with the description as a whole.

What is claimed is:

1. A magnetic fluid seal, the magnetic fluid seal comprising:
 - a pole ring having an inner diameter;
 - a rotatable shaft having an outer diameter, the rotatable shaft configured to extend along the inner diameter of the pole ring between an atmosphere side and vacuum side;
 - magnets coupled to the pole ring, the magnets configured to emit a magnetic field having a strength and a shape;
 - sealing grooves formed on either the inner diameter of the pole ring or the outer diameter of the shaft, wherein the sealing grooves extend between an atmosphere side of the magnetic fluid seal and a vacuum side of the magnetic fluid seal; and
 - wherein the fluid is applied so that either (1) the sealing grooves located nearer to the atmosphere side contain more ferrofluid than the sealing grooves located on the vacuum side, or (2) the sealing grooves located nearer to the vacuum side contain more ferrofluid than the sealing grooves located on the atmosphere side.
2. The magnetic fluid seal of claim 1, wherein at least one of the grooves does not contain any ferromagnetic fluid.
3. The magnetic fluid seal of claim 1, wherein the grooves are formed on the inner diameter of the pole ring.
4. The magnetic fluid seal of claim 1, wherein the grooves are formed on the outer diameter of the shaft.

1/3

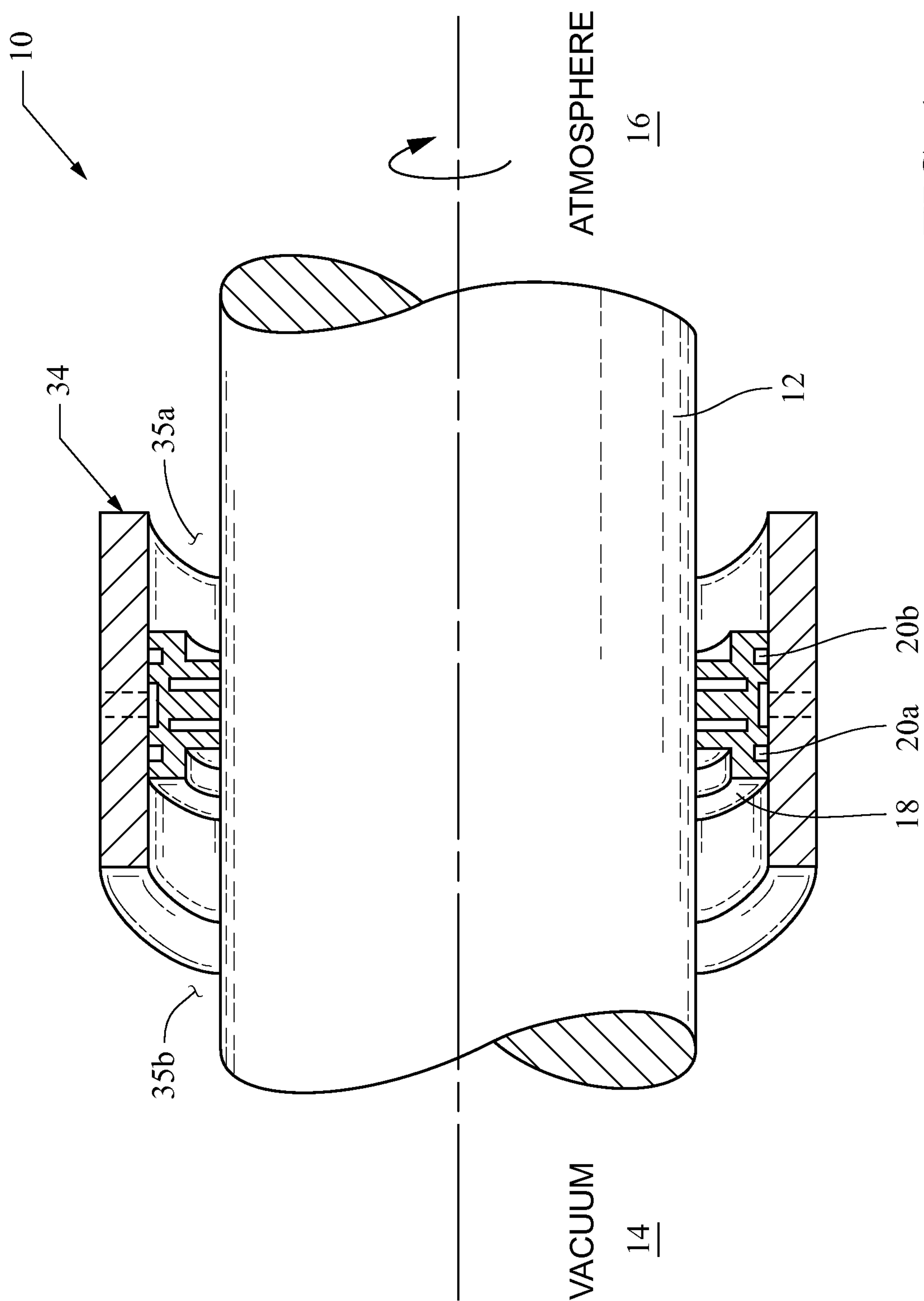

FIG. 1

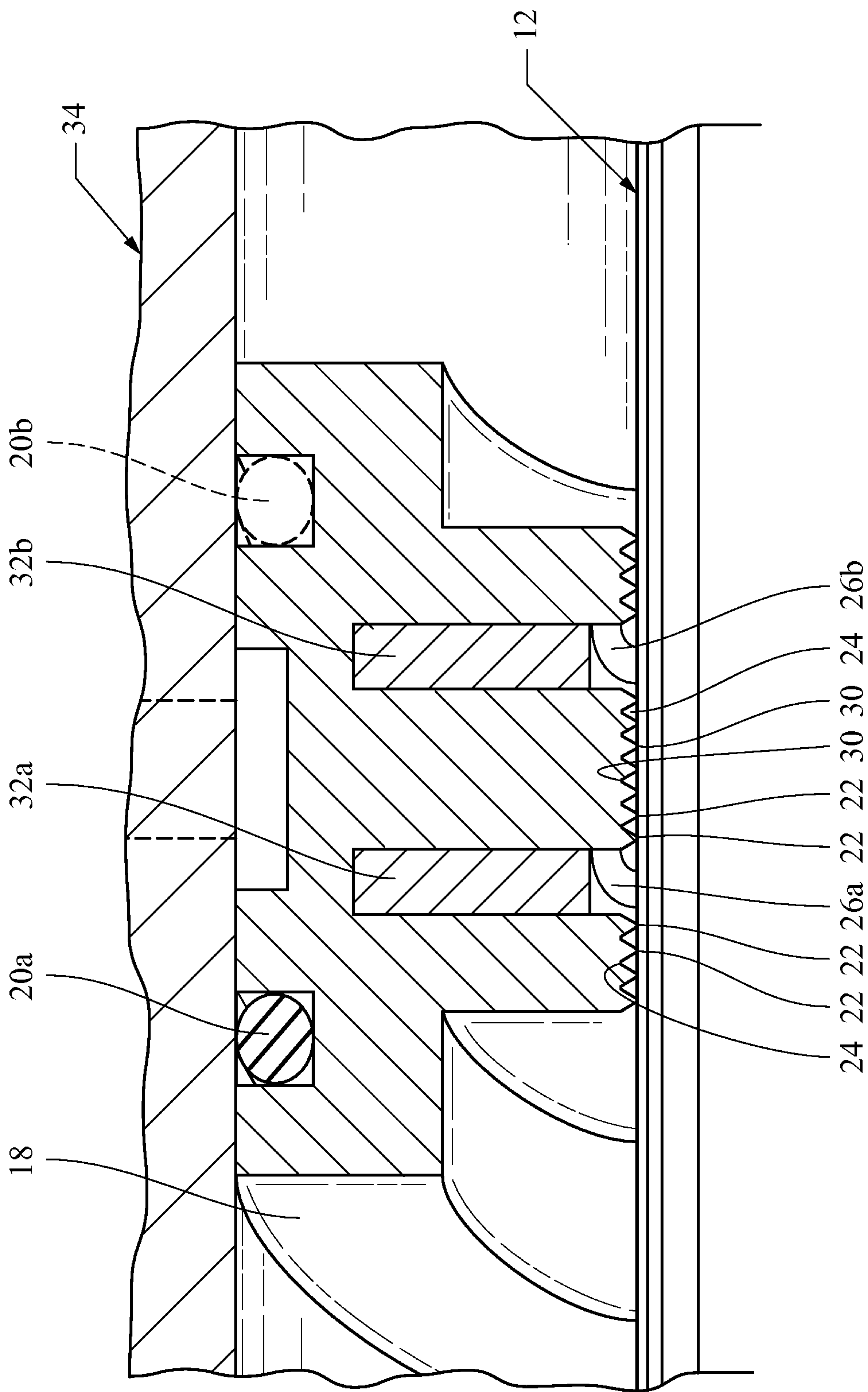

FIG. 2

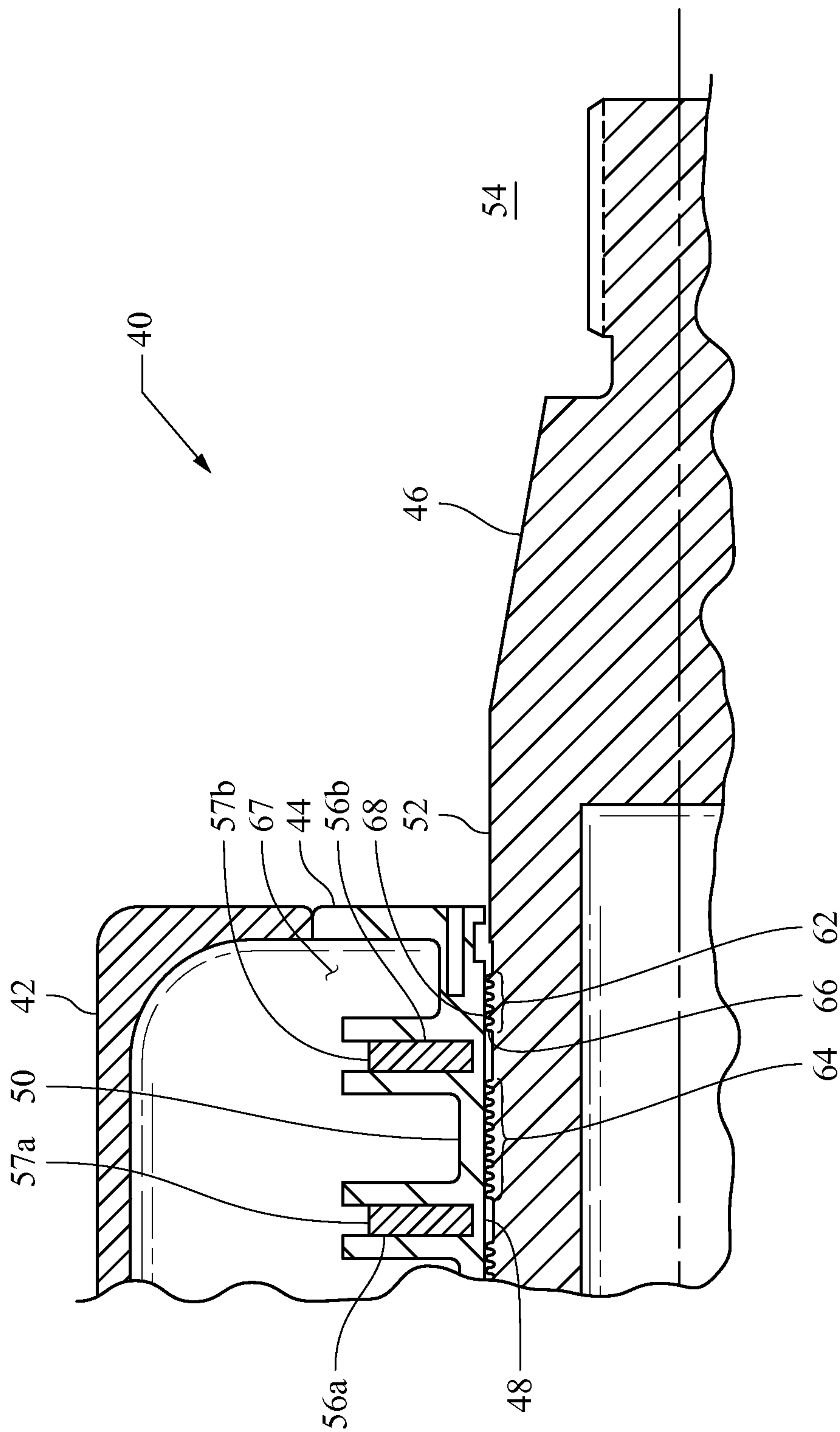

FIG. 3

