

A. DUIS.  
 ACETYLENE GAS GENERATOR.  
 APPLICATION FILED MAY 28, 1913.

1,088,064.

Patented Feb. 24, 1914.

2 SHEETS—SHEET 1.

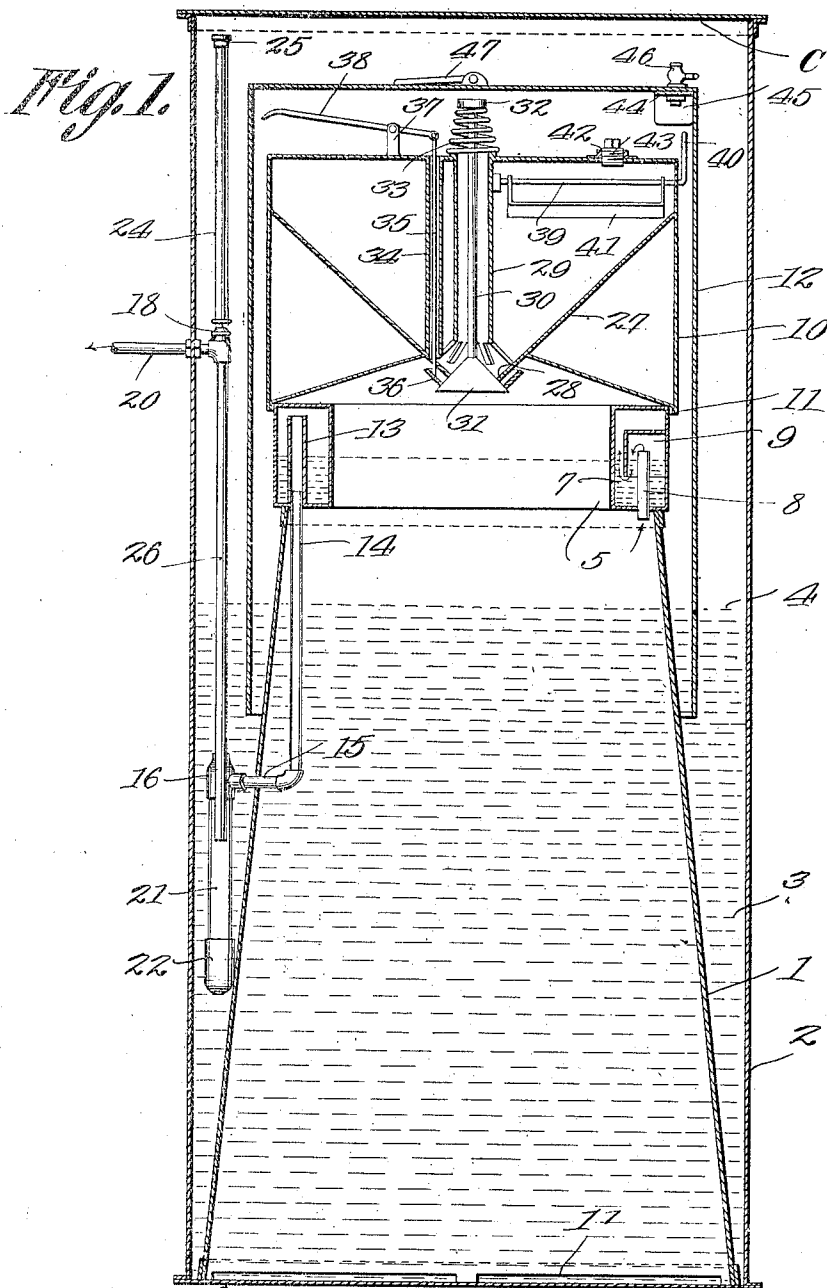

Witnesses  
*J. P. Tomlin*  
*S. Willough*

*Albert Duis* Inventor,  
 by *Carroll Co.* Attorneys.

1,088,064.

Patented Feb. 24, 1914.

2 SHEETS—SHEET 2.

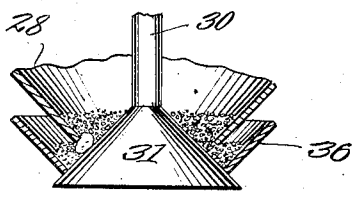
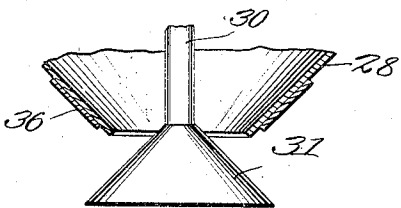
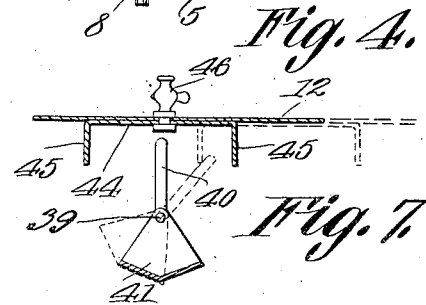
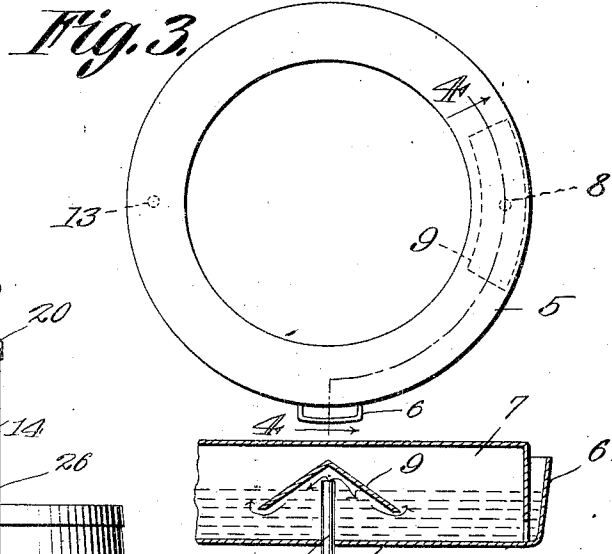
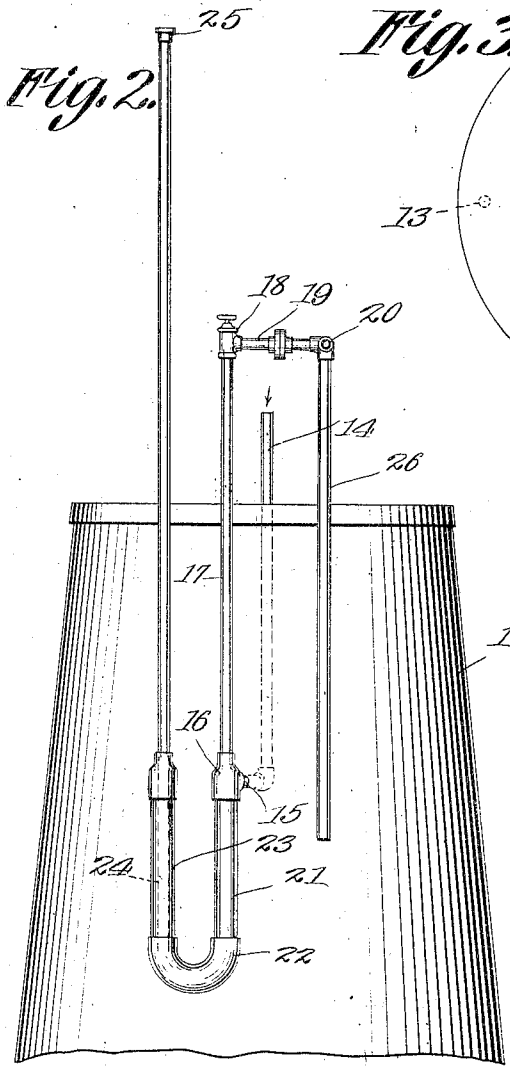

Witnesses  
*J. P. ...*  
*S. Willson*

*Albert Duis* Inventor,  
 by *Cadnow & Co.* Attorneys.

# UNITED STATES PATENT OFFICE.

ALBERT DUIS, OF STREATOR, ILLINOIS.

ACETYLENE-GAS GENERATOR.

1,088,064.

Specification of Letters Patent.

Patented Feb. 24, 1914.

Application filed May 28, 1913. Serial No. 770,505.

*To all whom it may concern:*

Be it known that I, ALBERT DUIS, a citizen of the United States, residing at Streator, in the county of La Salle and State of Illinois, have invented a new and useful Acetylene-Gas Generator, of which the following is a specification.

The present invention relates to improvements in acetylene gas generators, one object of this invention being the provision of a generator, in which an outer casing and a tapered or frusto-conical member insertible therewithin fits therewithin and constitutes the generating chamber, forming at the same time a sealing chamber for the bell slidably mounted upon the upper end of the generating chamber.

A still further object of the invention is the provision of means for preventing the carbid from interfering with the closure of the valve, so that should the valve be held slightly open by the carbid between it and the outlet of the hopper, the amount of carbid passing through such outlet will be retained by an auxiliary means which constitutes with such carbid a closure for the outlet of the hopper and thus prevents the continuous flow of the smaller carbid into the generating chamber when the valve is not fully seated.

With the foregoing and other objects in view which will appear as the description proceeds, the invention resides in the combination and arrangement of parts and in the details of construction hereinafter described and claimed, it being understood that changes in the precise embodiment of the invention herein disclosed can be made within the scope of what is claimed without departing from the spirit of the invention.

In the drawings—Figure 1 is a vertical central sectional view through the complete generator. Fig. 2 is a side elevation of the generating chamber showing the conduits led therefrom and also the condensation receiving and directing pipes. Fig. 3 is a top plan view of the gas washing device. Fig. 4 is a section taken on line 4—4 of Fig. 3. Figs. 5 and 6 are enlarged detail sectional views of the valve and auxiliary valves of the carbid hopper. Fig. 7 is an enlarged detail view illustrating a reserve carbid holder and the means for emptying the same.

Referring to the drawings, B designates the base, which is preferably made of metal

and has resting thereupon the frusto-conical generator 1, which with the outer cylindrical casing 2, which is connected to the base to form a water tight joint, forms the concentric sealing chamber 3 and as the member 1 is provided with the openings 1' at the bottom thereof, the water admitted into the sealing chamber will also fill the generating member 1 approximately to the line 4 as illustrated in Fig. 1. By this means, it will be seen that the water that is used for sealing the bell 12 also fills the generator member 1 for the generation of the acetylene gas.

Removably mounted upon the upper end or rim of the member 1, is the gas washing member 5, which is made in the form of a hollow ring, the same being provided with the inlet or filling spout 6 to the gas washing chamber 7. A gas inlet pipe 8 is carried by the member 5 and opens at a point above the water within the chamber 7 below the deflector 9, which is so disposed as to cause the gas to pass downwardly into the water in the direction of the arrows, as shown in Fig. 1, whereby any of the impurities are washed out of the gas before the delivery of such gas into the outlet pipes 13 and 14, the pipe 13 being carried by the member 5 and telescopically fitting upon the upper end of the pipe 14.

The carbid holder 10 is fitted so that its rim 11 surrounds the upper end of the gas washing member 5. Surrounding the upper end of the member 1 and also the carbid receptacle 10, is the bell 12, whose apron portion fits within the sealing compartment 3 below the water level 4.

It will thus be seen that the gas generated by the carbid falling into the water within the member 1, will cause the bell 12 to elevate, holding the same buoyantly as is the usual custom, the outlet for such gas being through the pipe 14 and the chamber 7 for the member 5, and the directing pipes 13 and 14. The lower end of the pipe 14 is mounted at 15 through the wall of the member 1 and enters the coupling 16, from which leads upwardly, the vertical pipe 17, which when the parts are assembled as in Fig. 1, is disposed exteriorly of the bell 12 within the casing 2, the pipe 20 being disposed through the wall of the casing 2 and led to the outlets (not shown). A valve 18 is connected in the pipe 17 and led from the valve 18 is the union connection 19 so that

the parts may be readily connected and disconnected, and also so that the valve 18 may be closed to permit of the removal of the condensates as will presently appear.

5 In order to provide a means for receiving the condensates from the gas as it enters the coupling 16 from the pipe 15, a pipe 21 is connected to the lower portion of the coupling 16 and has the return member 22 connected thereto and to the pipe 23, a smaller  
10 pipe 24 having its end disposed within the pipe 23, as clearly illustrated in dotted lines Fig. 2, and extended upwardly to a point adjacent to the cover C of the member 2  
15 so that said cap 25 may be removed and a suction pump attached thereto, to drain the condensate from the pipes 21 and 24 and the return member 22. To further safe guard the gas, so that any condensate may be prevented from entering the outlet pipe 20, a  
20 pipe 26 is connected to the union coupling member 19 at a point adjacent the connection of the pipe 20 thereto, and such pipe enters the sealing compartment 3 below the upper surface of the water, so that any condensate will run down such pipe into the water in the sealing compartment.

The carbid holder 10, as clearly shown in Fig. 1, carries the funnel shaped hopper  
30 27 whose outlet end 28 is disposed to be projected to provide a frusto-conical outlet portion. A tube 29 is disposed concentrically of the hopper member 27 and has slidably mounted therein the rod or stem 30,  
35 which carries upon its lower end, the conical valve 31, the upper end of the stem being provided with the button 32 and the spring 33, said spring normally holding the valve in seated position, as shown in Fig. 1, and  
40 permitting such valve to be depressed and opened due to the upper end of the bell 12 engaging the button 32 as the bell lowers, due to the decreasing volume of gas in the bell.

45 As is often the case, upon the automatic return or closure of a valve as 31, particles of carbid may be interposed between the valve and the rim of the member 28, so as to prevent the full closure of the valve, as  
50 clearly shown in Fig. 6, and in order to provide a means to prevent the sifting of the carbid through the space between the valve and the outlet 28, a tapered ring 36 controlled by the rod 35 is provided, this rod  
55 35 being mounted through the tube 34 carried by the carbid holder and as clearly shown in Figs. 1, 5 and 6.

The auxiliary ring or valve 36 is so disposed, as to normally rest upon the projecting  
60 portion of the valve 31, as clearly shown in Fig. 1, or it may be moved through the instrumentality of the lever 38, which is connected to the upper end of the rod 35 and pivoted upon the stud 37 so as to assume the position, as shown in Fig. 5, or

flush against the under side of the outlet portion of the holder 27.

It will be seen that when the bell 12 lowers, due to the fall of the gas pressure therein, that the under side of the top thereof will engage the button 32 and thus lower  
70 the valve 31, so that carbid will be precipitated into the water of the generating member 1, and that the continued depression of the bell will engage the upper free end of the lever 38, so as to move the auxiliary band or ring valve 36 to the position shown  
75 in Fig. 5. As the carbid enters the water, acetylene gas being generated, the increasing volume thereof will finally elevate the bell 12 and as soon as the top thereof gradually removes pressure upon the button 32, the spring 33 will gradually move the valve 31 to closed position, as shown in Fig. 1. As soon as the cover of the bell has disengaged the lever 38, the ring or auxiliary  
80 valve member 36 will fall by gravity to assume the position, as shown in Figs. 1 and 6; therefore should any particle of carbid prevent the full closure of the valve 31, it is evident that the ring or band 36 will coact with the valve member 31 to form an auxiliary receptacle for the carbid entering the same, thus forming a closure to prevent the continued falling of the carbid into the generating member 1. It will thus be seen that by  
85 a device of this character, that as soon as the pressure has elevated the bell sufficiently to permit of the proper closure of the valve 31, and such valve is hindered from full closure by the interference of any carbid particles, that the member 36 will prevent the undue wasting of the carbid and the consequent increase and undesirable pressure of the gas.

In order to provide a means, so that a reserved amount of carbid may be carried by the member 10, thus providing a means whereby a necessary amount may be held in  
90 reserve, should the volume of gas through the pipe 20 be so diminished during the hours of the evening, as to render it necessary to re-generate, it being impractical then to fill the holder 27, a rod 39 is journaled in the member 27 and carries the crank 40 exteriorly of the upper end thereof, the portion within the holder 27 being provided with the reserve carbid holder 41, which rests in the position to receive a charge of carbid through the aperture 42 closed by the  
95 plug 43. This reserve holder 41 is generally filled when the holder 27 is filled, so that it is ready to be emptied at any time it becomes necessary.

The crank or handle 41 generally assumes  
100 the upright position, as shown in Figs. 1 and 7, and is disposed, when the bell 12 is in lowermost position, to be in line to be engaged by either one of the depending aprons 45 of the supporting member 44, which is  
105 125 130

connected to and carried by the top of the bell 12 through the stop cock 46, so that when the bell is oscillated through the handle 47, either one of the aprons 45 will engage the crank 40 and tilt the reserve holder 41 to the dotted line position Fig. 7. This action will empty the reserve carbid into the holder 27, and as the valve 31 is opened due to the bell resting downwardly upon the button 32, the carbid dumped from the reserve holder 41 will pass through the outlet 28 into the water of the generator member 1.

The reserve holder 41 is of such a size as to carry sufficient carbid to generate sufficient gas for burning a period of approximately one night, so that the member or hopper 27 may be filled at leisure during the daytime.

From the foregoing description, taken in connection with the drawings, it is evident that with a generator constructed according to the present invention, that the water of condensation will be thoroughly removed from the gas before the passage thereof through the pipe 20, and that by means of the pipe 24, and the cover 25, a suction pump may be connected to the pipe 24 and thus draw the condensate from the member 22 and the pipes 21 and 23.

By reason of the valve 36, a great disadvantage in a valve controlled feed is overcome, this particular feature being of the utmost importance.

What is claimed is:

1. An acetylene gas generator, including a generator tank, a casing surrounding the generator tank, a bell slidably mounted above the upper end and around the generator tank, a carbid hopper disposed within

the bell above the generator tank, a spring closed valve controlling the hopper, said valve being open due to the fall of the bell, auxiliary means for preventing the spilling of the carbid from the hopper due to the non-seating of the valve, said means constituting a frusto-conical ring disposed concentrically of the outlet of the hopper and in coactive relation with the valve to provide with the valve a concentric receptacle to form with the released carbid a closure between the valve and the hopper.

2. An acetylene gas generator, including a generator tank, a casing surrounding the generator tank, a bell slidably mounted above the upper end and around the generator tank, a carbid hopper disposed within the bell above the generator tank, a spring closed valve controlling the hopper, said valve being open due to the fall of the bell, auxiliary means for preventing the spilling of the carbid from the hopper due to the non-seating of the valve, said means constituting a frusto-conical ring disposed concentrically of the outlet of the hopper and in coactive relation with the valve to provide with the valve a concentric receptacle to form with the released carbid a closure between the valve and the hopper, and means connected to the ring and in cooperative relation to the bell for elevating the ring out of contact with the valve during the automatic opening of the valve.

In testimony that I claim the foregoing as my own, I have hereto affixed my signature in the presence of two witnesses.

ALBERT DUIS.

Witnesses:

GEORGE RITENOUR,  
W. C. FRASER.