

T. J. McGowan,
Governor.

No 85,322.

Patented Dec. 29, 1868.

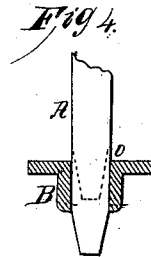
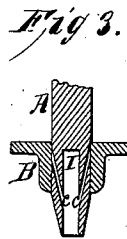
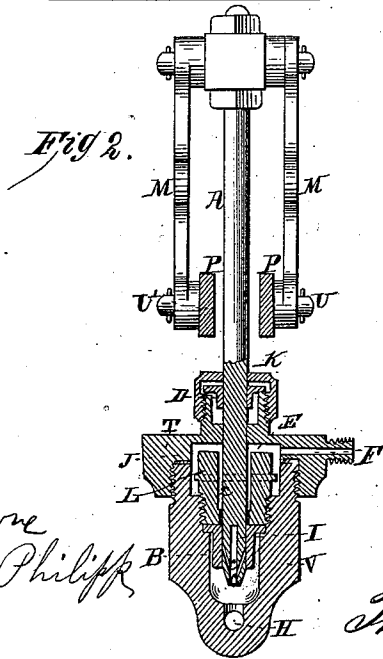
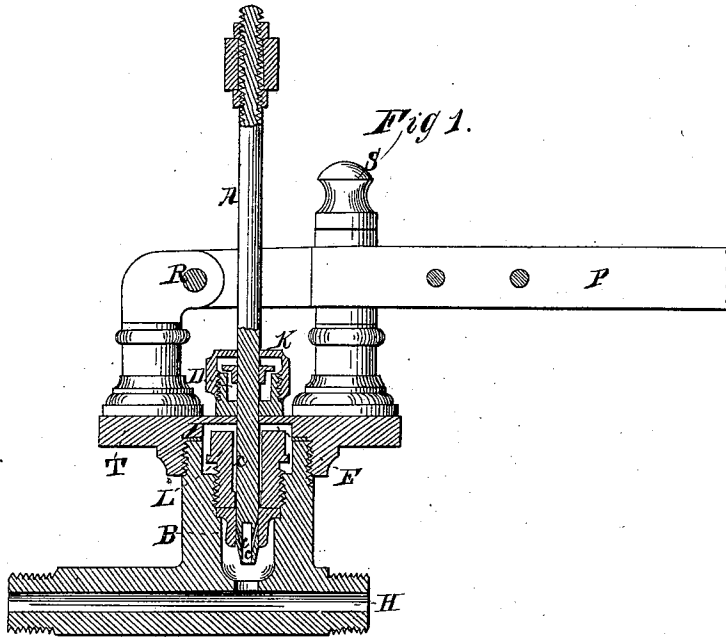

Witnesses.
James Moore
Moritz B. Philipp

Inventor
Theodore J. McGowan

United States Patent Office.

THEODORE J. MCGOWAN, OF CINCINNATI, OHIO.

Letters Patent No. 85,322, dated December 29, 1868.

IMPROVED HYDRAULIC-PRESSURE REGULATOR.

The Schedule referred to in these Letters Patent and making part of the same.

To all whom it may concern:

Be it known that I, THEODORE J. MCGOWAN, of Cincinnati, in the county of Hamilton, and State of Ohio, have invented a certain new and useful Automatic Hydraulic-Pressure Regulator; and I do hereby declare that the following is a full, clear, and exact description of the construction and operation of the same, reference being had to the annexed drawings, making part of this specification, in which—

Figure 1 is a vertical section of my automatic hydraulic-pressure regulator.

Figure 2 is a vertical section at right angles to fig. 1.

Figure 3 is a larger view of the piston A, with the small apertures *c c* below the packing.

Figure 4 is a view of the piston A, without the bore I, fig. 3.

The nature of my invention consists of an automatic hydraulic-pressure regulator. Its object is to permit the pumps of a hydraulic press, with which it may be connected, or a hydraulic pump, to be worked continuously while the press is in operation, and this is done by allowing any surplus water injected into the press, after the required pressure is attained, to escape, and thus prevent danger to the press from undue pressure.

Some of the advantages of my invention are:

First, where my automatic-pressure regulator is connected with a hydraulic press, there is no danger of breaking the press from any sudden increase of power consequent upon the continued action of the pumps after the substance then under pressure has ceased to yield to the force of the press.

Secondly, it is not necessary to stop the action of the pumps, while the press is in operation, until the substance then under pressure has been sufficiently compressed; whereas, before my invention, after a certain amount of pressure had been attained, the pumps required constant watching, and frequent stopping and starting, to prevent danger to the hydraulic press from too great pressure.

Thirdly, it is greatly superior to the ordinary safety-valve in this: It is the common experience of those who use safety-valves, for this or analogous purposes, that the immense force of the water causes the seat of the valve to leak in a very short time, sometimes a single operation of the pumps or press causing the most carefully-constructed valve to leak, after which the valve is an unsafe indicator.

At times, also, the valve adheres tenaciously to its seat, by reason of corrosion or other defects, after more than the amount of pressure which it was intended to prevent has been applied to it, and thus occasions the explosion of the cylinder or other receptacle of the water.

My automatic pressure-regulator is more easily moved, and more uniform in its action, and, as there is no friction of the point against a seat, it is not so liable to get out of order.

In the accompanying drawings like parts are designated by like letters.

In order that others skilled in the art may be able to construct and use my invention, I shall proceed to describe its construction and mode of operation.

A is a piston, suspended between the connecting-links M M.

P is a lever, composed of two pieces, pivoted to B, fig. 1, one of such pieces on each side, and to the connecting-links M M, at U and U', fig. 2, and passing around the post or standard S, fig. 1. There is a vertical slot in the centre of the post S, and between the two pieces of the lever there is a third piece riveted, which works in the said slot, and keeps the lever firm.

T is a hollow piece, screwed on to the chamber V, and containing the circular space E.

L is a nut, screwed into the chamber V, leaving space *x* between it and the piston A.

B is packing, made of leather, or other suitable material, through which the piston works water-tight.

K is a nut, screwed over the top of the hollow piece T, and containing packing D, to prevent the escape of water.

H is a tube, through which the water passes on its way from the pump to the hydraulic press. Between the tube H and the chamber V there is free access for the water, and, when the press is in operation, the said chamber is always kept full of water as far up as the packing B.

Upon the lever P a weight is placed to keep the piston A firm against the pressure of the water, and the size of such weight will be the measure of the desired pressure.

The piston A may be hollow for a short distance up, as shown at I, figs. 1, 2, and 3, or it may be solid, as seen at fig. 4. When hollow it will have small holes, *c c*, leading from the bore I to the outside of the piston. Said holes should be at about the same angle as the decrease of the point of the piston, or parallel with said decrease, as shown in the drawings.

The number of the holes *c c* is immaterial, but they should be situated slightly in advance of each other, so that the escape of the water from them may be gradual, fig. 2.

The piston A passes freely through the nuts K and L, and the hollow piece T, its only points of contact being the packing D and B.

The space between the piston A and the nut L is much smaller immediately above the packing B than it is farther up, and increases gradually for some distance, after which it is of uniform width up to the space E, in the hollow piece T, fig. 2.

J, fig. 2, is packing, placed above the screw which fastens the hollow piece T to the chamber V, and below the point where the space X connects with the space E, to prevent the water escaping through or getting into the thread of said screw.

When, by the constant pumping of the water, the pressure is greater than is required, as regulated by the weight on the lever P, the surplus pressure will force the piston A up, until the exterior orifices of one or more of the holes *c c* is above the packing B, when the surplus water, if any, will escape into the space X, and if the piston, without the bore I, is used, it will be forced up until a portion of the smaller part of the piston is above the packing B, as shown at *o*, fig. 4, when the water will escape into the space E.

F is a vent-pipe, leading from the space E to the reservoir, fig. 2, and through which the water passing out of the holes *c c*, or at *o*, fig. 4, will escape after passing through the spaces X and E.

When the hydraulic regulator herein described is used upon a hydraulic press, a large pump may be used until the amount, or nearly the amount, of pressure desired is attained, when the larger pump may be stopped, and a smaller pump may be brought into requisition, which may be kept in constant operation, without danger to the press, until the operation is completely performed.

Having thus described my invention, I do not claim

the use of a safety-valve without seating for hydraulic pumps, whereby the spindle is kept water-tight, by passing through packing, as that shown is in the English letters of provisional protection of Bellhouse and Dorning; but

What I do claim as new, and desire to secure by Letters Patent, is—

1. In a hydraulic-pressure regulator the piston A, provided with the means shown at figs. 3 and 4, for the surplus water to escape, when the hydraulic-pressure regulator contains more than sufficient water to produce the power required, as previously regulated by the weight on the lever P, substantially as and for the purpose specified.

2. An automatic hydraulic-pressure regulator, containing the piston A, having the means of escape, *c c*, for the water, and aperture I, the nut L, having the space X, with the packing B, as and for the purpose specified.

THEODORE J. MCGOWAN.

Witnesses:

MORITZ B. PHILIPP,
JAMES MOORE.