

No. 776,924.

PATENTED DEC. 6, 1904.

E. B. LITTLE.
CATALOGUE BINDER.

APPLICATION FILED DEC. 27, 1902. RENEWED JULY 18, 1904.

NO MODEL.

2 SHEETS—SHEET 1.

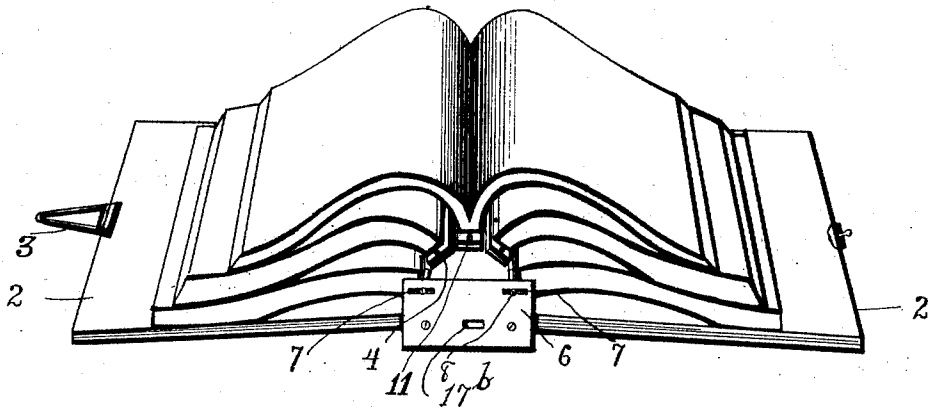

Fig. 1.

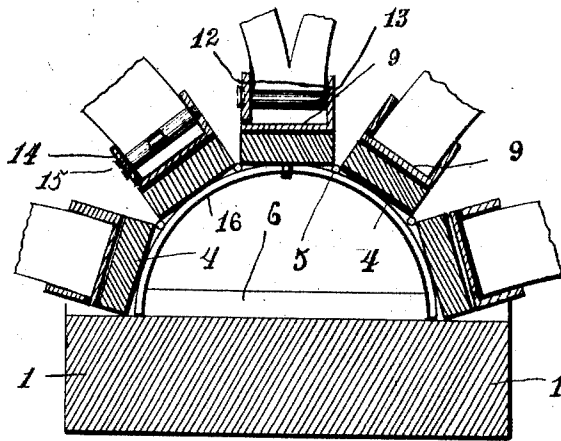

Fig. 2.

Witnesses:

Ernest Palmer,
Geo. A. Hutchinson

Inventor:-

Edmund B. Little.

by *Edson Prod.*
Attorney.

E. B. LITTLE.
CATALOGUE BINDER.

APPLICATION FILED DEC. 27, 1902. RENEWED JULY 18, 1904.

NO MODEL.

2 SHEETS—SHEET 2.

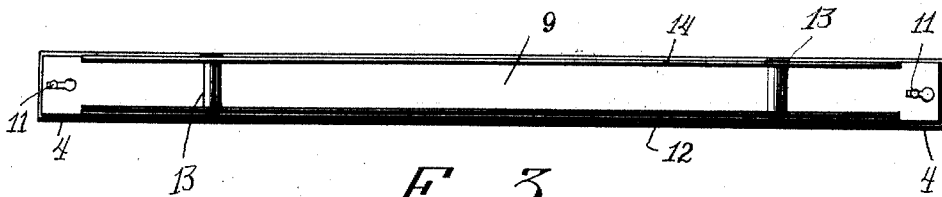

Fig. 3.

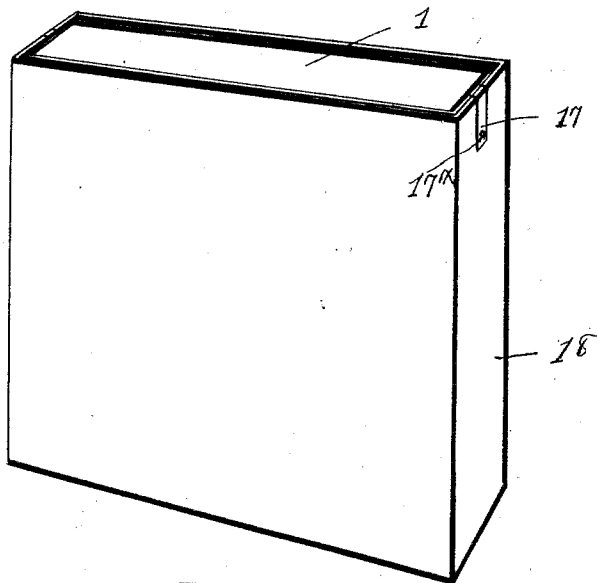

Fig. 4.

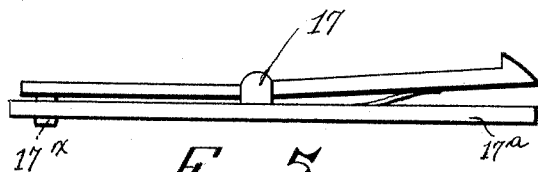

Fig. 5.

Witnesses:-

Geo. Hutchinson
Evert C. Palmer

Inventor:

Edmund B. Little.
by *Edwin Bird,*
Attorneys

UNITED STATES PATENT OFFICE.

EDMUND B. LITTLE, OF UNION CITY, TENNESSEE.

CATALOGUE-BINDER.

SPECIFICATION forming part of Letters Patent No. 776,924, dated December 6, 1904.

Application filed December 27, 1902. Renewed July 18, 1904. Serial No. 217,138. (No model.)

To all whom it may concern:

Be it known that I, EDMUND B. LITTLE, a citizen of the United States, residing at Union City, in the county of Obion and State of Tennessee, have invented certain new and useful Improvements in Catalogue-Binders; and I do hereby declare the following to be a full, clear, and exact description of the invention, such as will enable others skilled in the art to which it appertains to make and use the same.

My invention relates to certain improvements in what may be termed "binders," particularly for catalogues.

It has for its object more especially to provide for the convenient carrying of catalogues, particularly for salesmen's use, to permit of the insertion and removal of any one or more catalogues and to readily effect the same, to provide for the ready yielding of the catalogues in opening and closing the binder or device receiving said catalogues as against crumpling or buckling, &c., and to simplify the construction of the various parts and promote facility and convenience in the handling or using thereof.

Said improvements consist primarily of a series of flexibly-connected clamping devices or binders yieldingly connected to means supporting said clamping devices or binders and of the combination and arrangement of the individual parts thereof, substantially as hereinafter more fully disclosed, and specifically pointed out by the claims.

In the accompanying drawings, illustrating the preferred embodiment of my invention, Figure 1 is a view showing same spread open. Fig. 2 is an enlarged broken cross-section. Fig. 3 is a plan view of one of the base-bars with its binder. Fig. 4 is a view showing the parts inclosed within a case or closure. Fig. 5 is a detail view of one of the catches for holding the case or closure in locked position.

Latitude is allowed herein as to details, as the same may be changed, according as circumstances may suggest, without departing from the spirit of my invention and the same yet remain intact and be protected.

In carrying out my invention I preferably employ a base-plate or back 1, to which is flexibly connected in any suitable way covers

or lids 2, with a suitable clamping device 3 for connecting the same together at their free or longitudinal edges. The back proper, or what might be otherwise called the "backbone," 4, preferably comprises a series of longitudinal bars or strips articulated, hinged, or otherwise flexibly connected together at their lower longitudinal edges, as at 5, near each end thereof. The base or lateral bars of said series are movably or slidingly connected up with end plates 6, suitably secured to the base or back 1, said end plates having elongated or longitudinal slots 7 near each end thereof, receiving studs 8, which may be ordinary screws. Each of said longitudinal bars or strips is provided with a binder proper, 9, comprising a base-plate removably connected to the normally upper surface of said strip or bar, preferably having an enlarged-ended slot therein near each end, receiving headed studs or screws 11, projecting from each bar. Thus by moving said binders or plates endwise in one direction said binders proper may be readily removed when desired or necessary for renewal or otherwise. Each of said plates has an upstanding lateral flange or supplemental plate 12 at one of its longitudinal edges, stopping, preferably, a short distance inward from the ends of said first-referred-to plate. Said supplemental plate is provided, preferably, with two openings therethrough, and to its inner side around said openings are suitably secured sleeves or thimbles 13, extending crosswise of the plates 9. It will be observed that the catalogues are perforated so as to permit the slipping of the same upon said sleeves or thimbles in inserting the same in place upon the binders, and after thus slipping said catalogues upon said thimbles or sleeves a second supplemental plate or clamp 14, also having openings therein, is placed against said catalogues opposite to the supplemental plate 12. Preferably screws 15 are inserted into and through said thimbles or sleeves, engaging screw-threads in the distant ends of said sleeves, thus securing the catalogues effectively in place in said binders. A resilient or spring-wire piece 16 of preferably arcuate form is secured about centrally to the middle longitudinal strip or bar of the series of bind-

ers, said spring or wire bearing at its ends upon the inner surface of the back 1, the purpose of which is to automatically throw the series of binders up into arch form in opening the catalogues. This, it will be observed, permits the ready opening of the catalogues without crumpling and so as to allow them to lie approximately flat for ready examination when desired. Also it will be noted that by means of the sliding connection between the series of binders and the back 1, as above described, while the covers or lids 2 are permitted to lie flat upon the table or surface the catalogues are allowed to move independently thereof and readily conform to the desired position of the catalogues. When said backs or covers are clasped together, a closure or receptacle 18, preferably having an open bottom, is slipped upon the thus-bound catalogues and held or locked to the back 1, preferably by means of spring-pressed dogs or catches 17. Each catch or dog preferably comprises a spring-pressed lever pivoted to a base-plate 17^a, with lugs forming the fulcrum-point for said lever or dog, said dog or lever having near one end a thumb-piece or projection 17^x, protruding through an aperture in said base-plate for its ready actuation when it is desired to remove said closure or case. Said dogs are adapted to enter and engage the edges of perforations 17^b, produced in the end plate 6.

It will thus be seen that by means of my invention means are provided for the convenient transportation of said catalogues from place to place by the salesman and whereby said catalogues may be readily removed or inserted as occasion may require and whereby said catalogues are protected from the weather in thus transporting or carrying said catalogues.

Having thus described my invention, what I claim as new, and desire to secure by Letters Patent, is—

1. In a device of the character described, the combination with a back or base of a series of articulated binders for receiving catalogues, &c., and means for effecting sliding connection between said binders and said back or base.

2. In a device of the character described, the combination with a base or back of a series of articulated binders for receiving catalogues, &c., and end plates or supports having stud-and-slot connection with said binders.

3. In a device of the character described, the combination with a back or base of a series of binders for receiving catalogues, &c., comprising bars or strips articulated or hinged together, and means for effecting connection therebetween and said base or back.

4. In a device of the character described, the combination with a base or back of a series of binders for catalogues, &c., comprising longitudinal bars or strips articulated or hinged together, and end plates or supports secured

to said base or back, the lateral or base strips of said series having slot-and-stud connection with said end plates.

5. In a device of the character described, the combination with a base or back of a series of longitudinal strips or bars articulated or hinged together, of base-plates connected to said strips or bars provided with a longitudinal or lateral upstanding plate or flange provided with openings or perforations, and an additional supplemental plate, means adapted to effect connection between said catalogues and said plates, and means for effecting connection between said strips or bars and said back or base.

6. In a device of the character described, the combination, with a base or back, of a series of articulated bars or strips connected to said base or back, means connecting said strips or bars to said base, said strips or bars being equipped with binders proper for receiving the catalogues, &c., comprising a base-plate having a supplemental longitudinal plate at one edge provided with sleeves or tubes opposite perforations or openings in said supplemental plate, an additional supplemental plate arranged opposite to the first-named supplemental plate and having openings or perforations coincident with said sleeves or tubes, and means inserted through said tubes or sleeves and perforations effecting connection therebetween and said catalogues.

7. In a device of the character described, the combination, with a base or back, of a series of articulated or hinged-together longitudinal bars or strips, means for effecting connection between said series of bars and said back or base, and binders proper for receiving catalogues, &c., comprising a base-plate having a supplemental plate along one longitudinal edge, provided with sleeves or tubes opposite perforations in said supplemental plate, an additional supplemental plate having openings or perforations coincident with said tubes and perforations, and screws or fastenings inserted through the perforations of said supplemental plates and said sleeves or tubes, effecting connection therebetween and said catalogues.

8. In a device of the character described, the combination, with a base or back, of a series of articulated or hinged-together strips or bars, means for effecting connection between said strips or bars and said back or base, and binders proper each comprising a base-plate having slot-and-stud connection with a strip or bar, and provided with a supplemental plate along one longitudinal edge thereof having perforations therein and sleeves or tubes arranged coincidently with said perforations, and an additional supplemental plate arranged at the opposite longitudinal edge of said base-plate, and means effecting connection between said plates and said catalogues.

9. In a device of the character described, the

combination with a base or support having end plates provided with slots, of a series of articulated or hinged-together strips or bars having end studs passing through or sliding in said slots, and a series of base-plates having slot-and-stud connection with said bars or strips, each base-plate having a supplemental plate or flange along one longitudinal edge thereof, provided with perforations and sleeves or studs arranged coincidentally with said perforations, an additional supplemental plate arranged opposite the aforesaid supplemental plate and having perforations registering with said sleeves or tubes, and screws inserted through said perforations and sleeves or tubes, effecting connection therebetween and catalogues inserted therein.

10. In a device of the character described, the combination, with catalogue-binders, connected to a base having end plates provided with slots, said base also having flexibly connected thereto backs or lids adapted to be clasped together, of a closure or case adapted to be fitted upon said lids or covers and having at opposite ends or portions spring-pressed pawls or catches adapted to engage slotted end plates secured to said back or base.

11. A device of the character described, comprising a common back, a series of temporary binders having their individual backs flexibly connected together and means for their connection to said common base or back.

12. A device of the character described, comprising a common back, a series of temporary binders having their individual backs flexibly connected together and means for effecting sliding connection therebetween and said common base or back.

13. A device of the character described, comprising a common base or back, a series of temporary binders having their individual backs flexibly connected together, means adapted to hold the same normally in arched position, and means for connecting said binders to said common base or back.

14. A device of the character described, comprising a common base or back, a series of temporary binders having their individual backs flexibly connected together, means for effecting connection between said binders and said base or back, and means for automatically bowing or arching said binders.

15. A device of the character described, comprising a series of binders yieldingly or flexibly connected together, a common base therefor, means for connecting said binders to said base, and a resilient connection between said binders, adapted to bear on said base.

In testimony whereof I affix my signature in presence of two witnesses.

EDMUND B. LITTLE.

Witnesses:

S. WADDELL,
A. J. HARPOLE.