

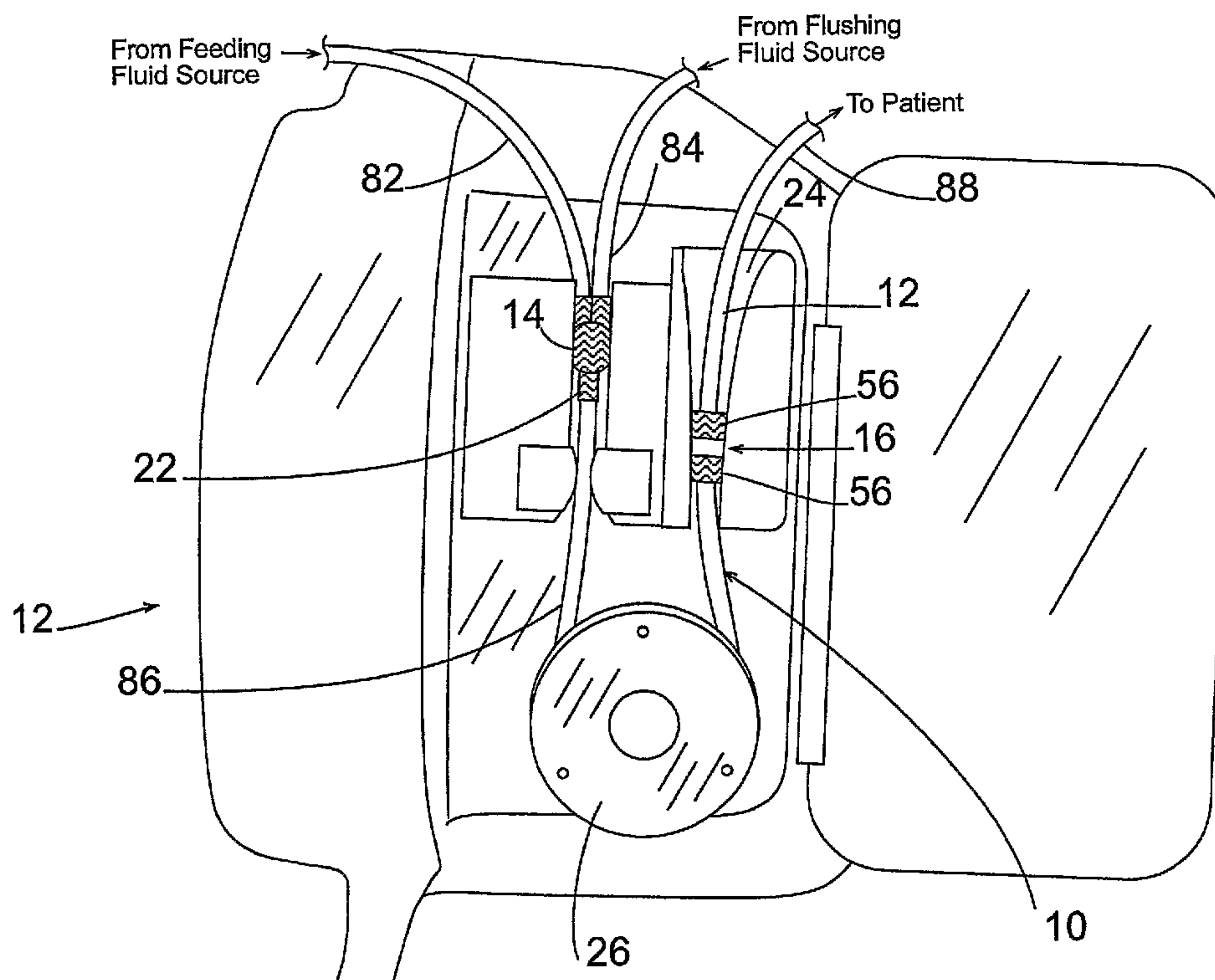

(86) Date de dépôt PCT/PCT Filing Date: 2005/05/25
 (87) Date publication PCT/PCT Publication Date: 2005/12/08
 (85) Entrée phase nationale/National Entry: 2006/11/01
 (86) N° demande PCT/PCT Application No.: US 2005/018343
 (87) N° publication PCT/PCT Publication No.: 2005/115501
 (30) Priorité/Priority: 2004/05/25 (US10/853,958)

(51) Cl.Int./Int.Cl. *A61M 5/00* (2006.01)
 (71) Demandeur/Applicant:
 SHERWOOD SERVICES, AG, CH
 (72) Inventeurs/Inventors:
 FOURNIE, GLENN G., US;
 MEIER, KEVIN C., US;
 SISK, RICKY A., US;
 TRELFOED, PAUL, US;
 HARR, JAMES, US
 (74) Agent: SMART & BIGGAR

(54) Titre : ENSEMBLE A GAVAGE D'ADMINISTRATION ET MECANISME DE VANNE
 (54) Title: ADMINISTRATION FEEDING SET AND VALVE MECHANISM



(57) **Abrégé/Abstract:**

An administration feeding set (10) adapted to be loaded to a flow control apparatus (12) is disclosed. The administration feeding set (10) comprises tubing (60) adapted suitably for fluid flow, a valve mechanism (14) suitable for loading the administration feeding set (10) to the flow control apparatus (12), and a mounting member (16) adapted suitably for permitting identification of the functional configuration of the administration feeding set (10). Also disclosed is a method for administering fluid utilizing the administration feeding set (10). There are also disclosed novel valve mechanisms (14).

(12) INTERNATIONAL APPLICATION PUBLISHED UNDER THE PATENT COOPERATION TREATY (PCT)

(19) World Intellectual Property Organization
International Bureau(43) International Publication Date
8 December 2005 (08.12.2005)

PCT

(10) International Publication Number
WO 2005/115501 A3

(51) International Patent Classification:

A61M 5/00 (2006.01)

(21) International Application Number:

PCT/US2005/018343

(22) International Filing Date: 25 May 2005 (25.05.2005)

(25) Filing Language: English

(26) Publication Language: English

(30) Priority Data:

10/853,958 25 May 2004 (25.05.2004) US

(63) Related by continuation (CON) or continuation-in-part (CIP) to earlier application:

US 10/853,958 (CON)
Filed on 25 May 2004 (25.05.2004)

(71) Applicant (for all designated States except US): SHERWOOD SERVICES, AG [CH/CH]; Postfach 1571, Bahnhofstrasse 29, CH-8201 Schaffhausen (CH).

(72) Inventors; and

(75) Inventors/Applicants (for US only): FOURNIE, Glenn, G. [US/US]; 5221 White Oak Drive, Smithton, Illinois

62285 (US). MEIER, Kevin, C. [US/US]; 6931 Greenholly Drive, Affton, Missouri 63123 (US). SISK, Ricky, A. [US/US]; 15 Oak Valley Drive, Washington, Missouri 63090 (US). TRELFOED, Paul [US/US]; 4600 Candleglow Drive, St. Louis, Missouri 63129 (US). HARR, James [US/US]; 221 Woods Creek Drive, Foristell, Missouri 63348 (US).

(74) Agents: BAI, Ari, M. et al.; Tyco Health Care Group, LP, Intellectual Property Department Docketing, 15 Hampshire Drive, Mansfield, MA 02048 (US).

(81) Designated States (unless otherwise indicated, for every kind of national protection available): AE, AG, AL, AM, AT, AU, AZ, BA, BB, BG, BR, BW, BY, BZ, CA, CH, CN, CO, CR, CU, CZ, DE, DK, DM, DZ, EC, EE, EG, ES, FI, GB, GD, GE, GH, GM, HR, HU, ID, IL, IN, IS, JP, KE, KG, KM, KP, KR, KZ, LC, LK, LR, LS, LT, LU, LV, MA, MD, MG, MK, MN, MW, MX, MZ, NA, NG, NI, NO, NZ, OM, PG, PH, PL, PT, RO, RU, SC, SD, SE, SG, SK, SL, SM, SY, TJ, TM, TN, TR, TT, TZ, UA, UG, UZ, VC, VN, YU, ZA, ZM, ZW.

(84) Designated States (unless otherwise indicated, for every kind of regional protection available): ARIPO (BW, GH, GM, KE, LS, MW, MZ, NA, SD, SL, SZ, TZ, UG, ZM, ZW), Eurasian (AM, AZ, BY, KG, KZ, MD, RU, TJ, TM),

[Continued on next page]

(54) Title: ADMINISTRATION FEEDING SET AND VALVE MECHANISM

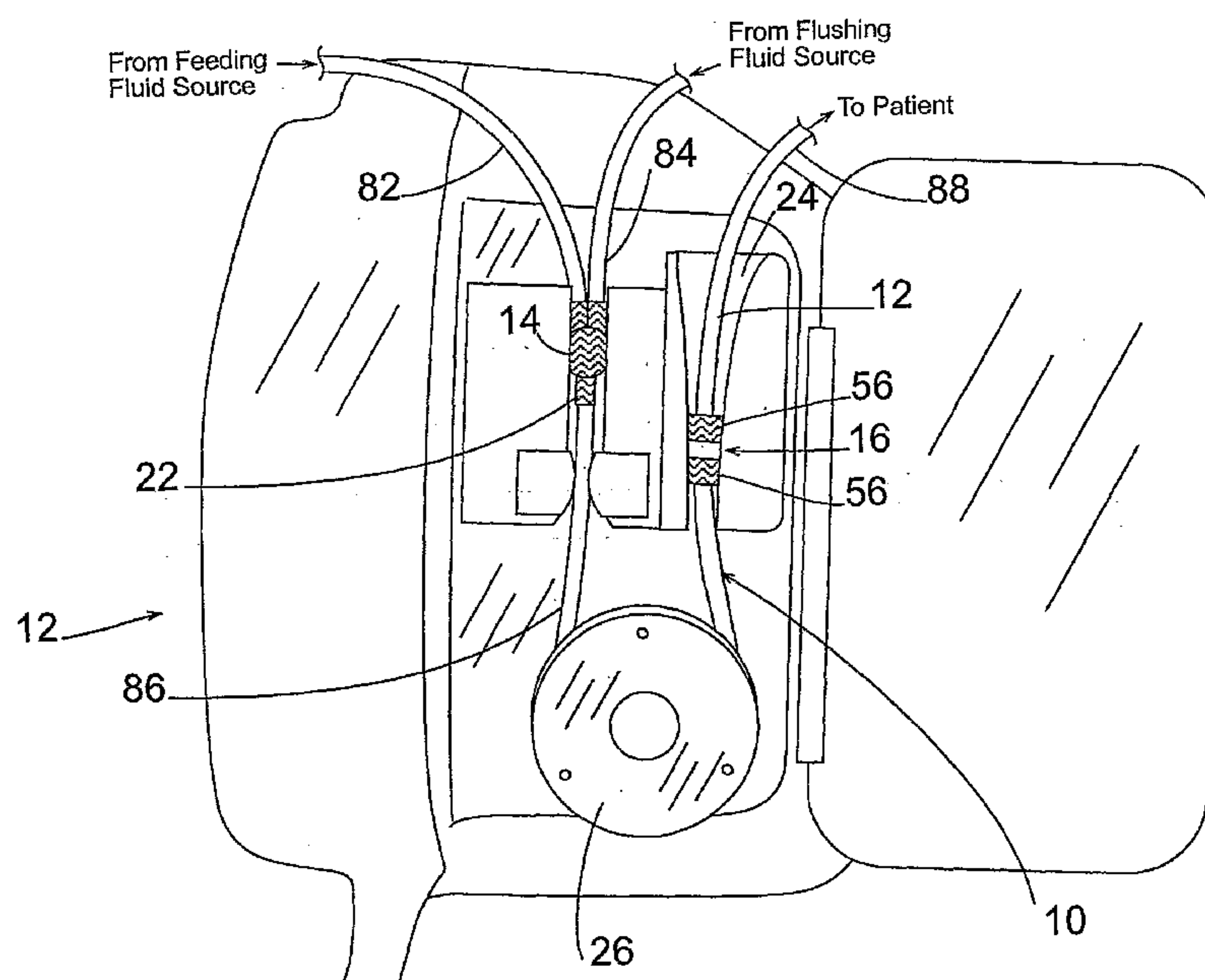

(57) Abstract: An administration feeding set (10) adapted to be loaded to a flow control apparatus (12) is disclosed. The administration feeding set (10) comprises tubing (60) adapted suitably for fluid flow, a valve mechanism (14) suitable for loading the administration feeding set (10) to the flow control apparatus (12), and a mounting member (16) adapted suitably for permitting identification of the functional configuration of the administration feeding set (10). Also disclosed is a method for administering fluid utilizing the administration feeding set (10). There are also disclosed novel valve mechanisms (14).

WO 2005/115501 A3

WO 2005/115501 A3



European (AT, BE, BG, CH, CY, CZ, DE, DK, EE, ES, FI, FR, GB, GR, HU, IE, IS, IT, LT, LU, MC, NL, PL, PT, RO, SE, SI, SK, TR), OAPI (BF, BJ, CF, CG, CI, CM, GA, GN, GQ, GW, ML, MR, NE, SN, TD, TG).

Published:

- *with international search report*
- *before the expiration of the time limit for amending the claims and to be republished in the event of receipt of amendments*

(88) Date of publication of the international search report:
2 November 2006

For two-letter codes and other abbreviations, refer to the "Guidance Notes on Codes and Abbreviations" appearing at the beginning of each regular issue of the PCT Gazette.

ADMINISTRATION FEEDING SET AND VALVE MECHANISM

**Glenn G. Fournie, James Harr, Kevin Meier,
Ricky A. Sisk and Paul Trelford**

FIELD OF THE INVENTION

5 The present invention relates to an administration feeding set adapted to be loaded to a flow control apparatus. The present invention further relates to a valve mechanism adapted to be engaged to a flow control apparatus.

10

BACKGROUND OF THE INVENTION

 Administering fluids containing medicine or nutrition to a patient is well known in the art. Typically, fluid is delivered to the patient by an administration feeding set loaded to a flow control apparatus, such as a peristaltic pump, which delivers fluid to the patient at a controlled rate of delivery. The administration feeding set, when loaded to the flow control apparatus, comprises tubing that delivers fluid from a fluid source to a patient.

20

 A valve mechanism may be located on the tubing for permitting or preventing fluid flow communication through the administration feeding set. Such a valve mechanism may be automatically operated to alternate positions that either prevent or permit fluid flow communication through the tubing when engaged to the flow control apparatus.

25

Often times it may be difficult to identify administration feeding sets having different functional configurations for performing different kinds of tasks since each type of administration feeding set has a physical appearance that may be indistinguishable from other kinds of administration feeding sets. Accordingly, it is important that the healthcare practitioner be able to readily identify the functional configuration of the administration feeding set being loaded to the flow control apparatus.

Therefore, there is a need for an administration feeding set having a means for identifying the functional configuration of the feeding set and having a valve mechanism that can prevent disengagement of the administration feeding set loaded to the flow control apparatus.

SUMMARY OF THE INVENTION

The present invention comprises an administration feeding comprising tubing adapted for fluid flow and further adapted to be loaded to the flow control apparatus. A valve mechanism is in direct communication with the tubing and adapted to engage the flow control apparatus. Further, the administration feeding set comprises a mounting member in direct communication with the tubing, wherein the mounting member is adapted to engage the tubing to the flow control apparatus and comprises a means for permitting identification of the functional configuration of the administration feeding set.

In another embodiment, the administration feeding set comprises tubing adapted for fluid flow and further adapted to be loaded to the flow control apparatus. Further, the administration feeding set comprises a mounting member in direct communication with the tubing, wherein the mounting member is adapted to engage the tubing to the flow control apparatus and comprises a means for permitting identification of the functional configuration of the administration feeding set.

10

The present invention further relates to a valve mechanism that comprises a valve body having at least one inlet in communication with an outlet through a chamber and a valve stem rotatably disposed in the chamber. The valve stem has a portion comprising a fluid pathway defining at least one fluid port. This valve mechanism is suitable for controlling fluid flow.

15

In another embodiment, the valve mechanism comprises a valve body having at least one inlet in communication with an outlet through the chamber with the valve body further comprising a slot. A valve stem is rotatably disposed in the chamber with the valve stem having a portion comprising a channel. This valve mechanism is suitable for preventing disengagement of the valve mechanism from the flow control apparatus when the valve mechanism is in a position that permits fluid flow.

20

25

In yet another embodiment, the valve mechanism comprises a valve body having at least one inlet in communication with an outlet through a chamber with the

30

valve body further comprising a slot. A valve stem is rotatably disposed in the chamber. The valve stem has a front portion comprising a fluid pathway defining at least one fluid port and a back portion comprising a
5 channel. This valve mechanism is suitable for controlling fluid flow and for preventing disengagement of the valve mechanism from the flow control apparatus when the valve mechanism is in a position that permits fluid flow.

10

BRIEF DESCRIPTION OF THE DRAWINGS

FIG. 1 is a perspective view of an embodiment of the administration feeding set according to the present invention;

5

FIG. 2A is a side view of the administration feeding set loaded to a flow control apparatus according to the present invention;

10

FIG. 2B is a side view of an embodiment of a flow control apparatus prior to loading the administration feeding set thereto according to the present invention;

15

FIG. 3A is a partial perspective view of an embodiment of the valve mechanism shown in the feeding position according to the present invention;

20

FIG. 3B is a partial perspective view of the embodiment of the valve mechanism shown in the flushing position according to the present invention;

25

FIG. 3C is a perspective view of the embodiment of the valve mechanism shown in the blocking position according to the present invention;

30

FIG. 4 is a side view of the embodiment of the valve mechanism according to the present invention;

30

FIG. 5 is an end view of the embodiment of the valve mechanism according to the present invention;

FIG. 6 is a cross-sectional view of the embodiment of the valve mechanism taken along line 6-6 of FIG. 5 according to the present invention;

5 FIG. 7 is a cross-sectional view of the embodiment of the valve mechanism taken along line 7-7 of FIG. 4 according to the present invention;

10 FIG. 8 is a cross-sectional view of the embodiment of the valve mechanism taken along line 8-8 of FIG. 4 according to the present invention;

15 FIG. 9 is an opposing end view of the embodiment of the valve mechanism according to the present invention;

FIG. 10 is a bottom view of the embodiment of the valve mechanism according to the present invention;

20 FIG. 11A is a perspective view of an alternative embodiment of the valve mechanism shown in the feeding position according to the present invention;

25 FIG. 11B is a perspective view of the alternative embodiment of the valve mechanism shown in the blocking position according to the present invention;

30 FIG. 12 is a diagram of an embodiment of the mounting member with identification members attached to the lower and upper portions thereof according to the present invention;

FIG. 13 is a diagram of an embodiment of the mounting member with an identification member attached only to the lower portion thereof according to the present invention;

5

FIG. 14 is a diagram of an embodiment of the mounting member with an identification member attached only to the upper portion thereof according to the present invention;

10

FIG. 15 is a diagram of an embodiment of the mounting member with the identification members attached to the upper and lower portions and further illustrating the related sensor devices according to the present invention;

15

FIG. 16 is a diagram of an alternative embodiment of a mounting member with identification members attached to upper, middle and lower portions according to the present invention;

20

FIG. 17 is a simplified block diagram illustrating the various systems related to the administration feeding set loaded to the flow control apparatus according to the present invention; and

25

FIG. 18 is a flow chart of the software subsystem illustrating the process used to detect and identify a functional configuration of an administration feeding set adapted to be loaded to the flow control apparatus according to the present invention.

30

DETAILED DESCRIPTION OF THE INVENTION

Referring to the drawings, an embodiment of the administration feeding set according to the present invention is illustrated and generally indicated as 10 in FIG. 1. This embodiment comprises an administration feeding set 10 adapted to be loaded to a flow control apparatus 12 suitable for delivery of fluid to a patient. In particular, the administration feeding set 10 comprises tubing 60 adapted for fluid flow communication and further adapted to engage the flow control apparatus 12 suitable for driving fluid through the tubing 60. A valve mechanism 14 is in direct communication with the tubing 60 and is adapted to permit or prevent fluid flow communication through the tubing 60 when valve mechanism 14 is engaged to the flow control apparatus 12. In addition, the administration feeding set 10 comprises a mounting member 16 in direct communication with the tubing 60, wherein the mounting member 16 permits identification of the functional configuration of the administration feeding set 10 by the flow control apparatus 12 upon engagement of the mounting member 16 to the flow control apparatus 12. The mounting member 16 also assists in the loading of the administration feeding set 10 to the flow control apparatus 12. As used herein, the term load means that the valve mechanism 14 and mounting member 16 are engaged to flow control apparatus 12 and tubing 60 is placed in a stretched condition between valve mechanism 14 and mounting member 16 such that the administration feeding set 10 is ready for operation with flow control apparatus 12.

In another embodiment, the administration feeding set 10 is identical to the previous embodiment with the exception that the valve mechanism 14 is absent.

5 In yet another embodiment of the present invention there is provided a novel valve mechanism 14 adapted to be engaged to flow control apparatus 12. The valve mechanism 14 is suitable for permitting or preventing fluid flow communication, as well as preventing
10 disengagement of the valve mechanism 14 from flow control apparatus 12 when the valve mechanism 14 is in a position that permits fluid flow communication.

ADMINISTRATION FEEDING SET

15 As noted above, the administration feeding set 10 comprises tubing 60 that provides a fluid pathway between at least one source of fluid and a patient. Tubing 60 comprises first tubing 86 engaged between the valve mechanism 14 and mounting member 16, and second
20 tubing 88 engaged between mounting member 16 and a connector 78, such as a barbed connector, suitable for attachment to a gastrostomy device attached to a patient. The valve mechanism 14 and mounting member 16 are adapted to engage the tubing 60 to the flow control
25 apparatus 12. As further shown, tubing 60 further comprises third tubing 82 engaged between a feeding fluid source 21 and valve mechanism 14, and fourth tubing 84 engaged between a flushing fluid source 23 and valve mechanism 14, wherein the valve mechanism 14
30 provides a means for permitting flow of feeding fluid or flushing fluid, or preventing fluid flow communication through tubing 60.

Referring to FIGS. 2A, 2B and 17 exemplary components and systems of the administration feeding set 10 and flow control apparatus 12 according to an embodiment of the present invention are illustrated. Flow control apparatus 12 comprises a housing 20 that defines first and second recesses 22 and 24 adapted to load the administration feeding set 10 to flow control apparatus 12. A means for driving fluid through tubing 60, such as a rotor 26, is operatively engaged to and through the housing 20 and is adapted to engage tubing 60. Flow control apparatus 12 further includes a sensor 17 (FIG. 15) that detects the engagement of mounting member 16 to second recess 24 and is in operative communication with a software subsystem 15 as explained in greater detail below. The valve mechanism 14 and rotor 26 are operatively engaged to a gear arrangement 25 driven by a single motor source 27. A suitable flow control apparatus 12 is disclosed in co-pending U.S. patent application serial number 10/854,136 filed on May 25, 2004 and herein incorporated by reference in its entirety. However, it is understood that any suitable flow control apparatus 12 may be used with administration feeding set 10.

25

As noted above, administration feeding set 10 comprises tubing 60 engaged to valve mechanism 14 and mounting member 16 adapted for loading the administration feeding set 10 to flow control apparatus 12. Referring specifically to FIGS. 2A and 2B, to load the administration feeding set 10 to the flow control apparatus 12, the valve mechanism 14 is engaged to first

recess 22, the first tubing 86 then wrapped around rotor 26, and the mounting member 16 engaged to second recess 24 such that first tubing 86 is placed in a stretched condition around rotor 26 and the administration feeding set 10 is ready for operation with flow control apparatus 12.

As used herein, the portion of tubing 60 leading to the rotor 26 is termed upstream, while the portion of tubing 60 leading away from the rotor 26 is termed downstream. Valve mechanism 14 is engaged to the upstream portion of tubing 60 at first recess 22 and controls the flow of fluid from the respective fluid source through administration feeding set 10, while the mounting member 16 is engaged to the downstream portion of tubing 60 at second recess 24 for loading the administration feeding set 10 to flow control apparatus 12. In an embodiment illustrated in FIG. 1, the feeding fluid source 21 and the flushing fluid source 23 are placed in fluid flow communication with valve mechanism 14 through tubing 60 for permitting or preventing fluid flow from either the feeding or flushing fluid sources 21, 23. However, in another embodiment of the administration feeding set 10, valve mechanism 14 is absent and a means (not shown) for controlling fluid flow through tubing 60 is positioned in an area other than on the administration feeding set 10.

VALVE MECHANISM

The present invention further relates to a valve mechanism 14 that comprises a valve body 28 having at least one inlet 30, 32 in communication with an outlet

34 through a chamber 36 and a valve stem 38 rotatably disposed in the chamber 36. The valve stem 38 has a front portion 40 comprising a fluid pathway 44 defining at least one fluid port 46. This embodiment of valve mechanism 14 is suitable for controlling fluid flow.

In another embodiment, the valve mechanism 14 comprises a valve body 28 having at least one inlet 30, 32 in communication with an outlet 34 through a chamber 36 with the valve body 28 further comprising a slot 50. Valve stem 38 is rotatably disposed in the chamber 36 with the valve stem 38 having a back portion 42 comprising a channel 48. This embodiment of valve mechanism 14 is suitable for preventing disengagement of the valve mechanism 14 from the flow control apparatus 12 when the valve mechanism 14 is in a position that permits fluid flow.

In yet another embodiment, the valve mechanism 14 comprises a valve body 28 having at least one inlet 30, 32 in communication with an outlet 34 through a chamber 36 with the valve body 28 further comprising a slot 50. Valve stem 38 is rotatably disposed in the chamber 36. The valve stem 38 has a front portion 40 comprising a fluid pathway 44 defining at least one fluid port 46 and a back portion 42 comprising a channel 48. This embodiment of valve mechanism 14 is suitable for controlling fluid flow and for preventing disengagement of the valve mechanism 14 from the flow control apparatus 12 when the valve mechanism 14 is in a position that permits fluid flow.

Referring to FIGS. 3-10, valve mechanism 14 is adapted to be engaged to tubing 60 according to the present invention. As noted above, valve mechanism 14 comprises valve body 28 having a first inlet 30 adapted to be in communication with the feeding fluid source 21 through third tubing 82 and a second inlet 32 adapted to be in communication with a flushing fluid source 23 through fourth tubing 84 for providing fluid flow communication with an outlet 34 through chamber 36 interposed between first and second inlets 30, 32 and outlet 34. Valve body 28 further comprises slot 50 along the periphery thereof that is a structural arrangement adapted to receive a rotatable shaft 33 therethrough for operating the valve mechanism 14 as shall be discussed below. Preferably, valve body 28 includes a tab 29 that enables the user to easily engage valve mechanism 14 to flow control apparatus 10.

As noted above, valve stem 38 has front portion 40 comprising a fluid pathway 44 that defines at least one fluid port 46 to establish fluid flow through valve body 28. Fluid flow is established when valve stem 38 is rotated such that any one fluid port 46 is aligned with either the first or second inlets 30 and 32, thereby establishing fluid flow communication between first or second inlets 30, 32 and outlet 34.

Referring to FIGS. 2B, 3A-C, 6, and 17, channel 48 has opposed openings 48A and 48B adapted to engage rotatable shaft 33 when engaging the valve mechanism 14 to the first recess 22 of flow control apparatus 12. As shown, flow control apparatus 12 further comprises a

gear arrangement 25 operatively engaged to rotatable shaft 33 that is driven by the single motor source 27. The engagement between the valve mechanism 14 and the rotatable shaft 33 is accomplished by rotating the valve stem 38 and orienting channel 48 such that one of the openings 48A or 48B is aligned with slot 50 that permits the shaft 33 to be inserted into the interior portion of channel 48. Channel 48 provides a means for preventing disengagement of valve mechanism 14 from flow control apparatus 12 when the channel 48 is rotated to an orientation that misaligns the channel 48 with slot 50 and places the valve mechanism 14 in a position that permits fluid flow communication through tubing 60.

Conversely, the valve mechanism 14 permits disengagement from the flow control apparatus 12 when the channel 48 is rotated to an orientation that aligns one of the opposed openings 48A or 48B with slot 50 and places the valve mechanism 14 in a position that prevents fluid flow communication through tubing 60. More particularly, valve mechanism 14 must be placed in a blocking position that rotates valve stem 38 such that fluid ports 46 are in misalignment with both the first and second inlets 30, 32 to prevent fluid flow communication in order to disengage valve mechanism 14 from housing 20. When the flow control apparatus 12 directs rotatable shaft 33 through gear arrangement 25 to rotate valve stem 38 such that the valve mechanism 14 is placed in a blocking position shown in FIG. 10C, channel 48 is aligned with slot 50 while shaft 33 is disengaged through slot 50.

According to one aspect of the present invention, valve mechanism 14 is configured to prevent manual operation thereof by a user such that valve mechanism 14 can be operated only when engaged to the flow control apparatus 12. Specifically, valve stem 38 must be
5 engaged to shaft 33 in order to permit operation of the flow control apparatus 12, thereby making valve mechanism 14 difficult to operate manually and particularly useful as a tamper-proof device.

10

In operation, the rotation of valve stem 38 by the rotatable shaft 33 when driven by single motor source 27 prevents or permits fluid flow communication through administration feeding set 10 by valve mechanism 14.
15 Flow control apparatus 12 further includes a microprocessor 37 that controls the rotation of valve stem 38 so that either first inlet 30 or second inlet 32 is in alignment or misalignment with the fluid ports 46 when permitting or preventing fluid flow communication.
20 When any one of the fluid ports 46 is aligned with either of the first or second inlets 30, 32 fluid is permitted to flow into fluid port 46, through fluid pathway 44 and then exit out from outlet 34 as illustrated in FIGS. 3A, 3B and 6. Valve stem 38 is
25 rotated in only one direction, for example counter-clockwise, such that the valve stem 38 rotates the fluid pathway 44 in one direction only when aligning or misaligning any one of the fluid ports 46 with either first or second inlets 30, 32, thereby permitting a one-
30 way, multiple engagement operation between the fluid ports 46 and first and second inlets 30, 32 that either permits or prevents fluid flow communication. Referring

specifically to FIG. 6, when valve stem 38 aligns any one of fluid ports 46 with either first or second inlets 30, 32, fluid flow communication is established between either first or second inlets 30, 32 and outlet 34.

5

Based on the foregoing, when any one of the fluid ports 46 of valve stem 38 is aligned with any one of the first or second inlets 30, 32 to permit fluid flow communication the channel 48 is misaligned with slot 50, thereby preventing disengagement of the valve mechanism 14 from the flow control apparatus 12. When the fluid ports 46 are misaligned with the first and second inlets 30, 32 to prevent fluid flow communication the channel 48 is aligned with slot 50, thereby permitting disengagement of the valve mechanism 14 from flow control apparatus 12.

Referring to FIGS. 11A and 11B, an alternative embodiment of the valve mechanism designated 14A is illustrated according to the present invention. Valve mechanism 14A is similar in structure and operation to the preferred embodiment of valve mechanism 14, except there is only a single feeding inlet 63 for providing feeding fluid through the administration feeding set 10 from the feeding fluid source 21, rather than first and second inlets 30, 32 which permit both feeding and flushing functions. Accordingly, valve mechanism 14A alternates between a feeding position (FIG. 11A) for providing fluid to a patient and a blocking position (FIG. 11B) that prevents fluid flow communication.

ADMINISTRATION FEEDING SET IDENTIFIER SYSTEM

According to another aspect of the present invention, mounting member 16 assists in loading the administration feeding set 10 to the flow control apparatus 12 and is in operative communication with software subsystem 15 when engaged to second recess 24 which provides a means for identifying the type of administration feeding set 10. As shown in FIGS. 2A, and 12-17, mounting member 16 has an upper portion 52 and a lower portion 54 each adapted to receive an identification member 56 when attached thereto. Preferably, mounting member 16 has a cylindrical shape that concentrically surrounds tubing 60 and is configured to be engaged to second recess 24 when loading administration feeding set 10 to flow control apparatus 12 such that sensor 17 detects the presence of one or more identification members 56 attached to mounting member 16. Sensor 17 is preferably a Hall-effect sensor or other type of proximity sensor that is positioned near the second recess 24 such that sensor 17 can detect the presence of one or more identification members 56 when the mounting member 16 is engaged to second recess 24.

When mounting member 16 is engaged to second recess 24, the attachment of one or more identification members 56 to mounting member 16 provides a means for allowing software subsystem 15 to identify the functional configuration of the administration feeding set 10 loaded to flow control apparatus 12 and detected by sensor 17. Specifically, as shown in FIG. 12, mounting member 16 has at least one or more identification

members 56 attached thereto in accordance with an identification scheme that permits software subsystem 15 to identify the functional configuration of the administration feeding set 10 loaded to flow control apparatus 12. Preferably, identification members 56 are magnetic components or, in the alternative, magnetically-susceptible metallic components capable of detection by sensor 17 without requiring direct physical contact with sensor 17. In order to identify the functional configuration of the administration feeding set 10 loaded to flow control apparatus 12 microprocessor 37 is operatively associated with a database 134 containing one or more identification schemes for identifying different functional configurations for an administration feeding set 10.

According to another aspect of the present invention, an identification member 56 may be attached to the upper portion 52, lower portion 54, or both portions 52 and 54 of mounting member 16. The attachment of at least one identification member 56 to the mounting member 16 will vary to correspond with the number of different functional configurations. Each different functional configuration for an administration feeding set 10 will have a predetermined number and location of identification member(s) 56 attached to mounting member 16 that identifies the administration feeding set 10, such as feeding, flushing or re-certification, when mounting member 16 is detected by the sensor 17 and this data is communicated to the software subsystem 15 through microprocessor 37.

The recognition of the different number and attachment of identification members 56 to mounting member 16 and the identification of the type of functional configuration of administration feeding set 10 loaded to flow control apparatus 12 is based on a two-step process. First, sensor 17 detects the location and number of identification member(s) 56 when mounting member 16 is engaged to second recess 24; and second, software subsystem 15 that is in operative communication with sensor 17 determines the functional configuration of the loaded administration feeding set 10 based on the location and number of identification members 56 detected on mounting member 16 as shall be explained in greater detail below.

15

Referring to FIG. 15, sensor 17, for use with an embodiment of the software subsystem 15, comprises a pair of sensor devices 17A and 17B that detect the location and number of one or more identification members 56 attached to mounting member 16. Sensor 17 can be any known type of proximity sensor for detecting an identification member 56, preferably a magnetic component, or in the alternative a magnetically-susceptible metallic component, attached to mounting member 16. In addition, sensor 17 may also comprise any number of sensor devices with each sensor device corresponding to a portion of the mounting member 16 for detecting the presence of an identification member 56. In one embodiment, a pair of magnetic field proximity sensors or magnetic switch-type sensors may be provided, although the present invention contemplates that other types of sensors may be used, such as various inductive

coil arrangements. Sensor 17 is positioned near to second recess 24 such that each sensor device 17A and 17B is positioned relative to a corresponding portion in close proximity with mounting member 16 when
5 administration feeding set 10 is loaded to flow control apparatus 12. Upon engagement of mounting member 16, sensor 17A and sensor 17B are capable of detecting the presence of an identification member 56 attached to the corresponding upper and lower portions 52 and 54 of
10 mounting member 16.

In particular, sensor devices 17A and 17B are positioned near the second recess 24 in proximity to the upper and lower portions 52 and 54 of the mounting
15 member 16 and are capable of detecting a corresponding identification member 56 attached to portions 52 and 54, respectively. Accordingly, sensor device 17A is placed in a position to detect an identification member 56 attached to only on upper portion 52 of mounting member
20 16, while sensor device 17B is positioned to detect the presence of an identification member 56 attached only to the lower portion 54 of mounting member 16. As noted above, the present invention contemplates that a corresponding sensor device 17 is provided for each
25 additional portion of mounting member 16 adapted to receive an identification member 56.

As further noted above, software subsystem 15 provides a means for allowing the flow control apparatus
30 12 to identify the functional configuration of administration feeding set 10 loaded to flow control apparatus 12. FIG. 18 illustrates the sequence of steps

software subsystem 15 executes through microprocessor 37 to identify a functional configuration of administration feeding set 10 loaded to flow control apparatus 12 from a plurality of functional configurations. At decision point 318, software subsystem 15 determines whether or not an administration feeding set 10 is loaded to flow control apparatus 12. If the administration feeding set 10 is not loaded, then at step 324 the flow control apparatus 12 remains inoperative. However, if the administration feeding set 10 is loaded to flow control apparatus 12, the administration feeding set 10 and flow control apparatus are ready for operation once software subsystem 15 then identifies the functional configuration of administration feeding set 10 being loaded to flow control apparatus 12.

When engagement of mounting member 16 is detected at decision point 318, microprocessor 37 directs the flow control apparatus 12 to display an indication of such engagement to the user. At step 320, software subsystem 15 determines what functional configuration of administration feeding set 10 is loaded to the flow control apparatus 12 and ready for operation.

In order to identify the functional configuration of administration feeding set 10, software subsystem 15 executes a series of decision points 322, 326, and 328. At each of these decision points software subsystem 15 compares the number and placement of identification member 56 detected by sensor 17 with data stored in database 134.

At decision point 322, if sensor 17 detects an identification member 56 attached to both the upper and lower portions 52, 54 of mounting member 16, software subsystem 15 identifies the administration feeding set 10 as having a flushing configuration. However, if an identification member 56 is not detected at both the upper and lower portions 52, 54 then software subsystem 15 proceeds to decision point 326. At decision point 326, if sensor 17 detects an identification member 56 attached to only lower portion 54 information retrieved from database 134 identifies the administration feeding set 10 as having a re-certification configuration. However, if sensor 17 detects an identification member 56 attached only to the upper portion 52 of mounting member 16 at step 328, then software subsystem 15 determines that the administration feeding set 10 loaded to flow control apparatus 12 has a feeding configuration.

Once software subsystem 15 identifies the functional configuration of administration feeding set 10 loaded to flow control apparatus 12, microprocessor 37 directs that this information be displayed on user interface 40. Thus, software subsystem 15 is able to not only detect that the administration feeding set 10 is loaded, but also determine and display the functional configuration of the administration feeding set 10, such as feeding, flushing or re-certification loaded to the flow control apparatus 12. However, the present invention contemplates that alternate arrangements for placement of an identification member 56 attached to upper and lower portions 52, 54 may correspond to

different functional configurations for administration feeding set 10.

In an alternative identification scheme shown in
5 FIG. 16, an identification member 56 may be attached to
three different portions of a mounting member 16A, which
increases the total number of functional configurations
capable of being detected by the sensor 17 from three to
seven configurations. The present invention further
10 contemplates that increasing the number of portions on
mounting member 16A for engaging an identification
member 56 increases the number of different functional
configurations for administration feeding set 10 that
can be detected and identified by flow control apparatus
15 12. Preferably, the software subsystem 15 utilizes the
following equation to determine the number of functional
configurations for mounting member 16:

$$X = 2^n - 1$$

20

Wherein X is the number of potential different
functional configurations and n is the number of
portions along mounting member 16.

25

Preferably, mounting member 16A may be a concentric
sleeve having at least three separate portions with each
portion adapted to receive an identification member 56
according to one or more identification schemes. In
30 this alternative embodiment, mounting member 16A
preferably has a middle portion 58 in addition to the
upper and lower portions 52, 54 that are each adapted to

receive an identification member 56. Additionally, to
further increase the number of possible identification
schemes the polarity on any number of identification
members 56 may be reversed using techniques known in the
5 art in order to provide another means of detecting one
or more identification members 56 attached to mounting
member 16.

It should be understood from the foregoing that,
10 while particular embodiments of the invention have been
illustrated and described, various modifications can be
made thereto without departing from the spirit and scope
of the invention as will be apparent to those skilled in
the art.

15

CLAIMS

What is claimed is:

1. An administration feeding set (10) comprising:
tubing (60) adapted for fluid flow therethrough and
5 further adapted to be engaged to a flow control
apparatus (12),
a valve mechanism (14) in direct communication with
said tubing (60), said valve mechanism (14) adapted to
engage said flow control apparatus (12), and
10 a mounting member (16) in direct communication with
said tubing (60), said mounting member (16) adapted to
engage said tubing (60) to said flow control apparatus
(12) and said mounting member (16) comprising a means
for permitting identification of the functional
15 configuration of said administration feeding set (10).
2. The administration feeding set (10) according to
claim 1, wherein said tubing (60) is engaged to said
flow control apparatus (12).
- 20 3. The administration feeding set (10) according to
claim 1, wherein said valve mechanism (14) is engaged to
said flow control apparatus (12).
- 25 4. The administration feeding set (10) according to
claim 1, wherein said mounting member (16) is engaged to
said flow control apparatus (12).
5. The administration feeding set (10) according to
30 claim 1, wherein said valve mechanism (14) comprises a
valve body (28) having at least one inlet (30) in
communication with an outlet (34) through a chamber

(36), and a valve stem (38) rotatably disposed in said chamber (36), said valve stem (38) having a front portion (40) comprising a fluid pathway (44) defining at least one fluid port (46).

5

6. The administration feeding set (10) according to claim 1, wherein said valve mechanism (14) comprises a valve body (28) having at least one inlet (30, 32) in communication with an outlet (34) through a chamber
10 (36), said valve body (28) further comprising a slot (50), and a valve stem (38) rotatably disposed in said chamber (36), said valve stem (38) having a back portion (42) comprising a channel (48).

15

7. The administration feeding set (10) according to claim 1, wherein said valve mechanism (14) comprises a valve body (28) having at least one inlet (30, 32) in communication with an outlet (34) through a chamber
20 (36), said valve body (28) further comprising a slot (50), and a valve stem (38) rotatably disposed in said chamber (36), said valve stem (38) having a front portion (40) comprising a fluid pathway (44) defining at least one fluid port (46) and a back portion (42)
25 comprising a channel (48).

8. The administration feeding set (10) according to claim 1, wherein said means for permitting identification comprises at least one identification
30 member (56) attached to said mounting member (16).

9. The administration feeding set (10) according to claim 1, wherein said functional configuration is a feeding configuration.

5 10. The administration feeding set (10) according to claim 1, wherein said functional configuration is a flushing configuration.

10 11. The administration feeding set (10) according to claim 1, wherein said functional configuration is a re-certification configuration.

15 12. The administration feeding set (10) according to claim 1, wherein said mounting member (16) comprises upper and lower portions (52, 54) and said means for permitting identification is attached to said upper portion (52) and/or said lower portion (54) of said mounting member (16).

20 13. The administration feeding set (10) according to claim 1, wherein said valve mechanism (14) is placed in a position that permits fluid flow through said tubing (60).

25 14. An administration feeding set (10) comprising:
a) tubing (60) adapted for fluid flow therethrough and further adapted to be engaged to a flow control apparatus (12) and a mounting member (16) in direct communication with said tubing (60), said mounting member (16) adapted to engage said tubing (60) to said
30 flow control apparatus (12) and said mounting member (16) comprising a means for permitting identification of

the functional configuration of said administration feeding set (10).

15. A process for administering fluid comprising:

5 a) attaching one end of said tubing (60) according to claim 2 to at least one fluid source (21, 23),

b) attaching another end of said tubing (60) according to claim 2, and

10 c) administering fluid from said fluid source (21) using said administration feeding set (10) according to claim 2.

16. The process according to claim 15, wherein said another end of said tubing (60) is attached to a patient and wherein said fluid is administered to said patient.

17. A valve mechanism (14) comprising:

20 a) a valve body (28) having at least one inlet (30, 32) in communication with an outlet (34) through a chamber (36), and

b) a valve stem (38) rotatably disposed in said chamber (36), said valve stem (38) having a front portion (40) comprising a fluid pathway (44) defining at least one fluid port (46).

25

18. The valve mechanism (14) according to claim 17, further comprising tubing (60) engaged to said valve mechanism (14).

30 19. A valve mechanism (14) comprising:

a) a valve body (28) having at least one inlet (30, 32) in communication with an outlet (34) through a

chamber (36), said valve body (28) further comprising a slot (50), and

b) a valve stem (38) rotatably disposed in said chamber (36), said valve stem (38) having a back portion
5 (42) comprising a channel (48).

20. The valve mechanism (14) according to claim 19, further comprising tubing (60) engaged to said valve mechanism (14).

10

21. A valve mechanism (14) comprising:

a) a valve body (28) having at least one inlet (30, 32) in communication with an outlet (34) through a chamber (36), said valve body (28) further comprising a
15 slot (50), and

b) a valve stem (38) rotatably disposed in said chamber (36), said valve stem (38) having a front portion (40) comprising a fluid pathway (44) defining at least one fluid port (46) and a back portion comprising
20 a channel (48).

22. The valve mechanism (14) according to claim 21, further comprising tubing (60) engaged to said valve mechanism (14).

25

1/12

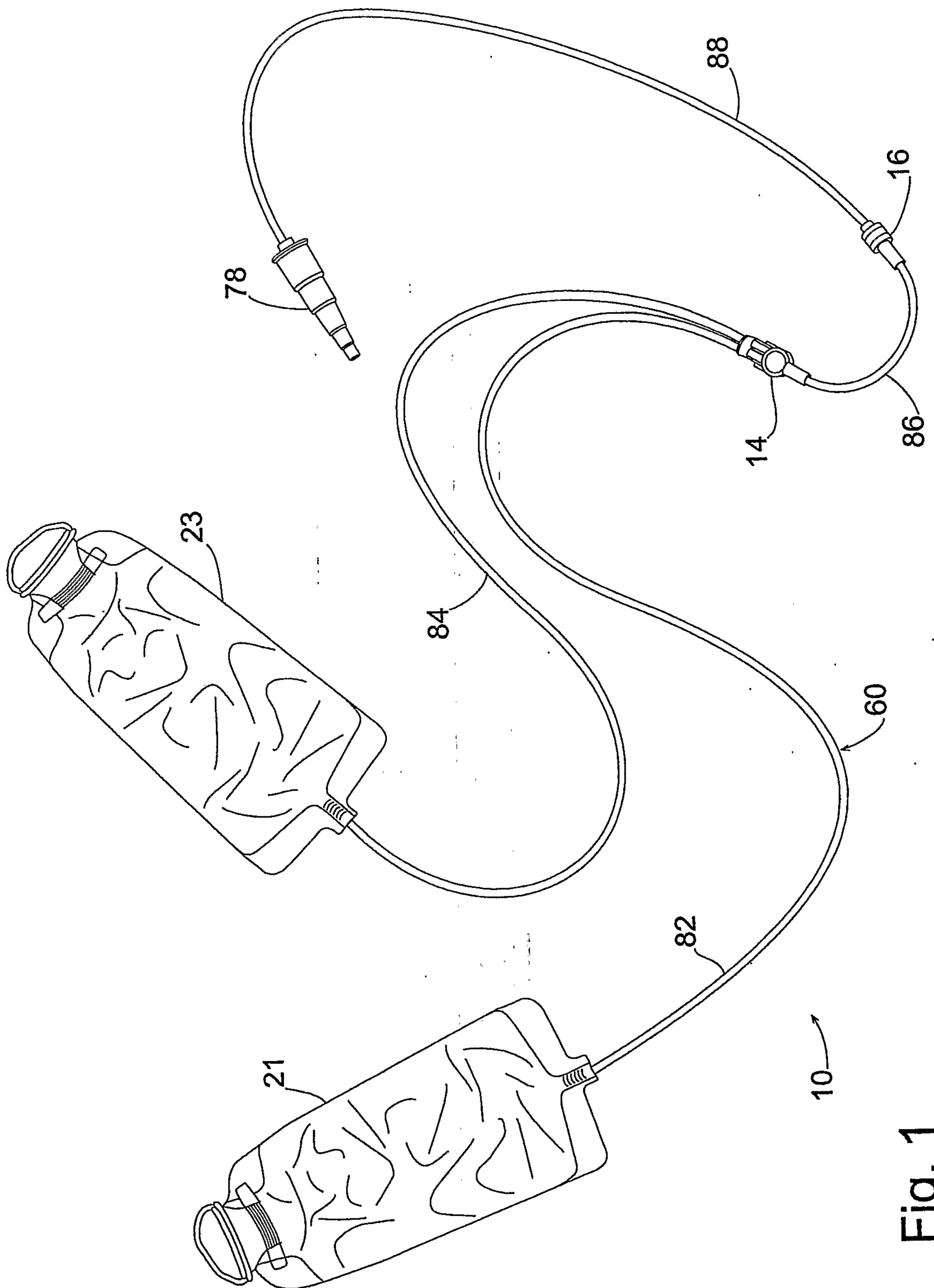

Fig. 1

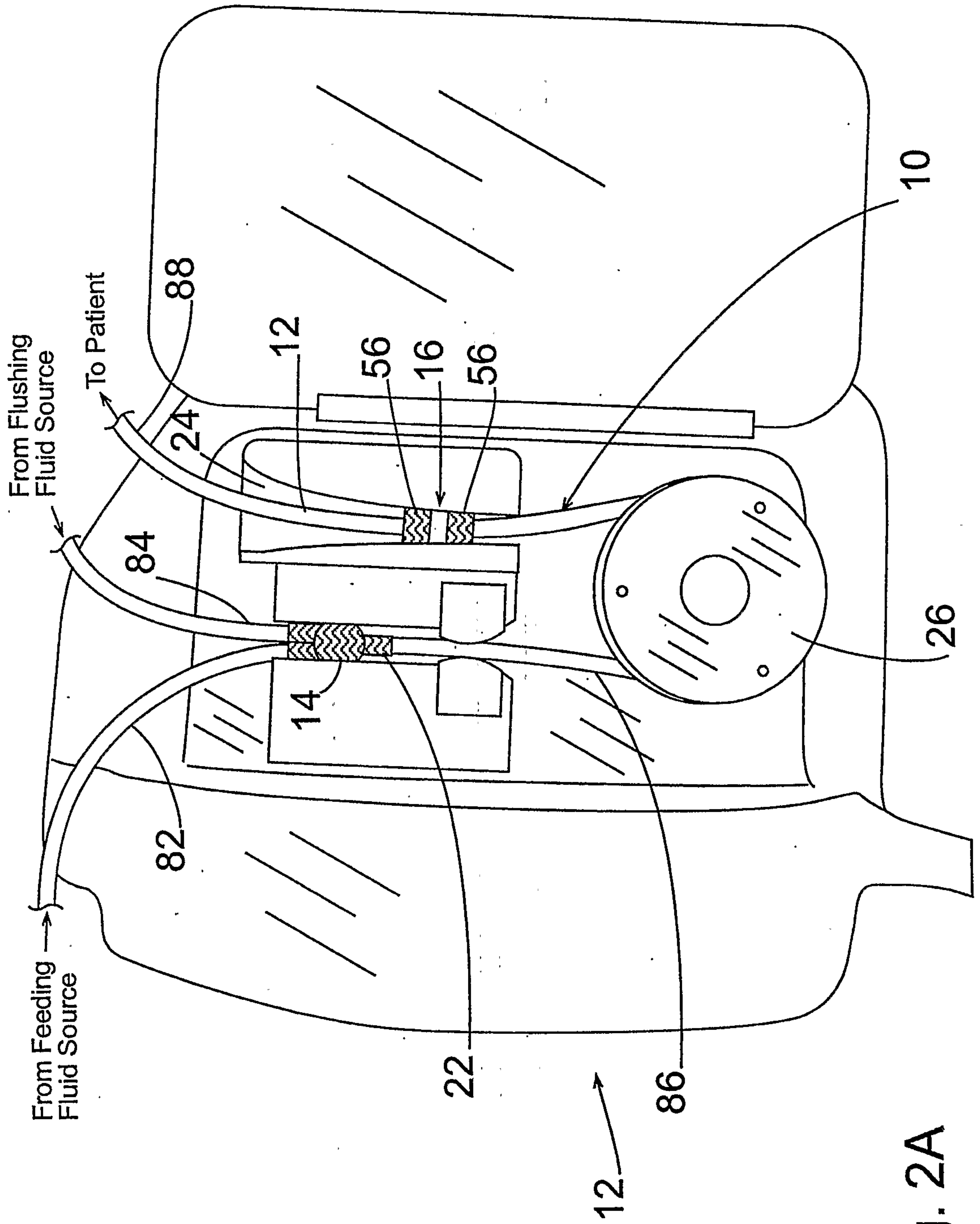

Fig. 2A

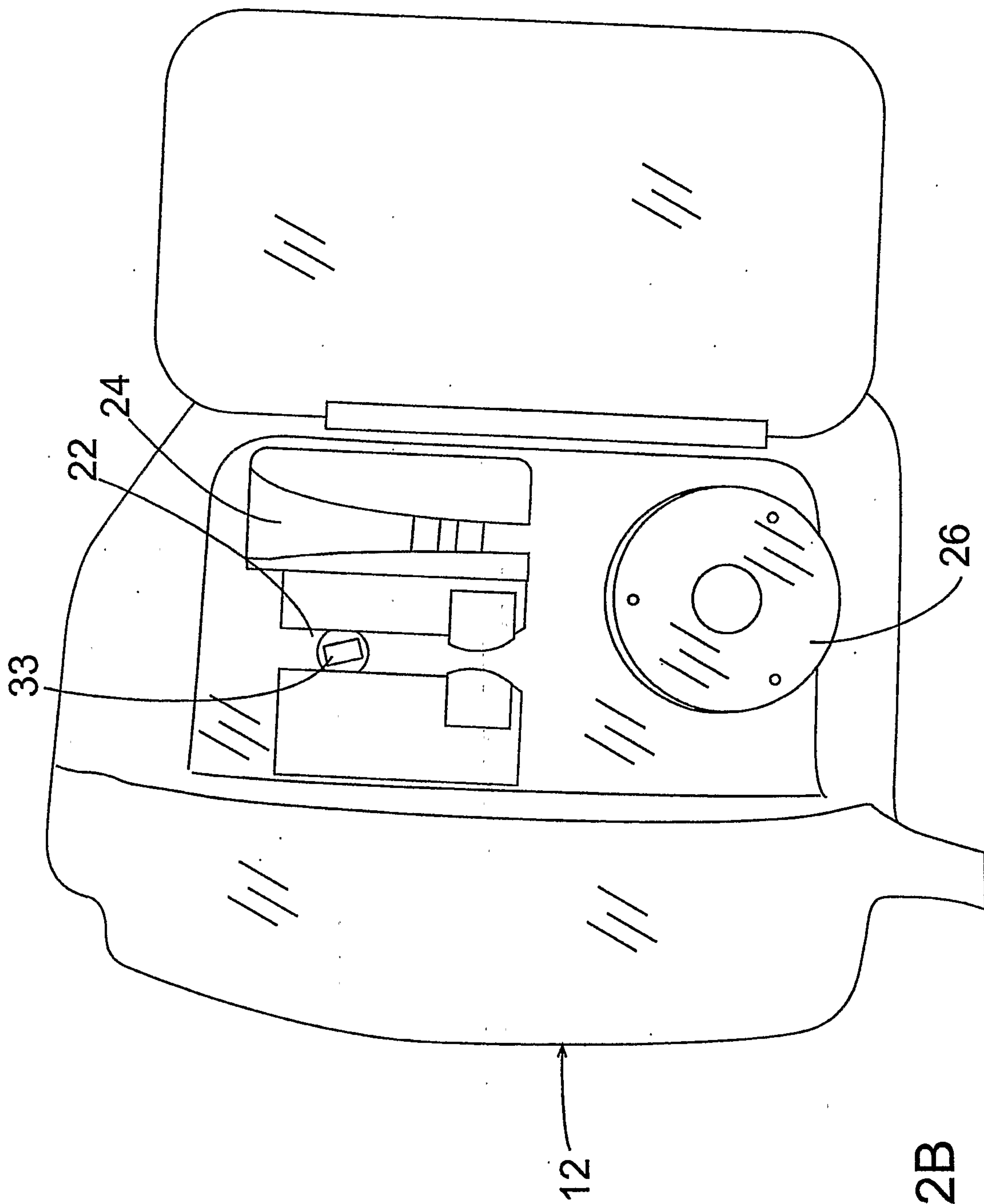

Fig. 2B

4/12

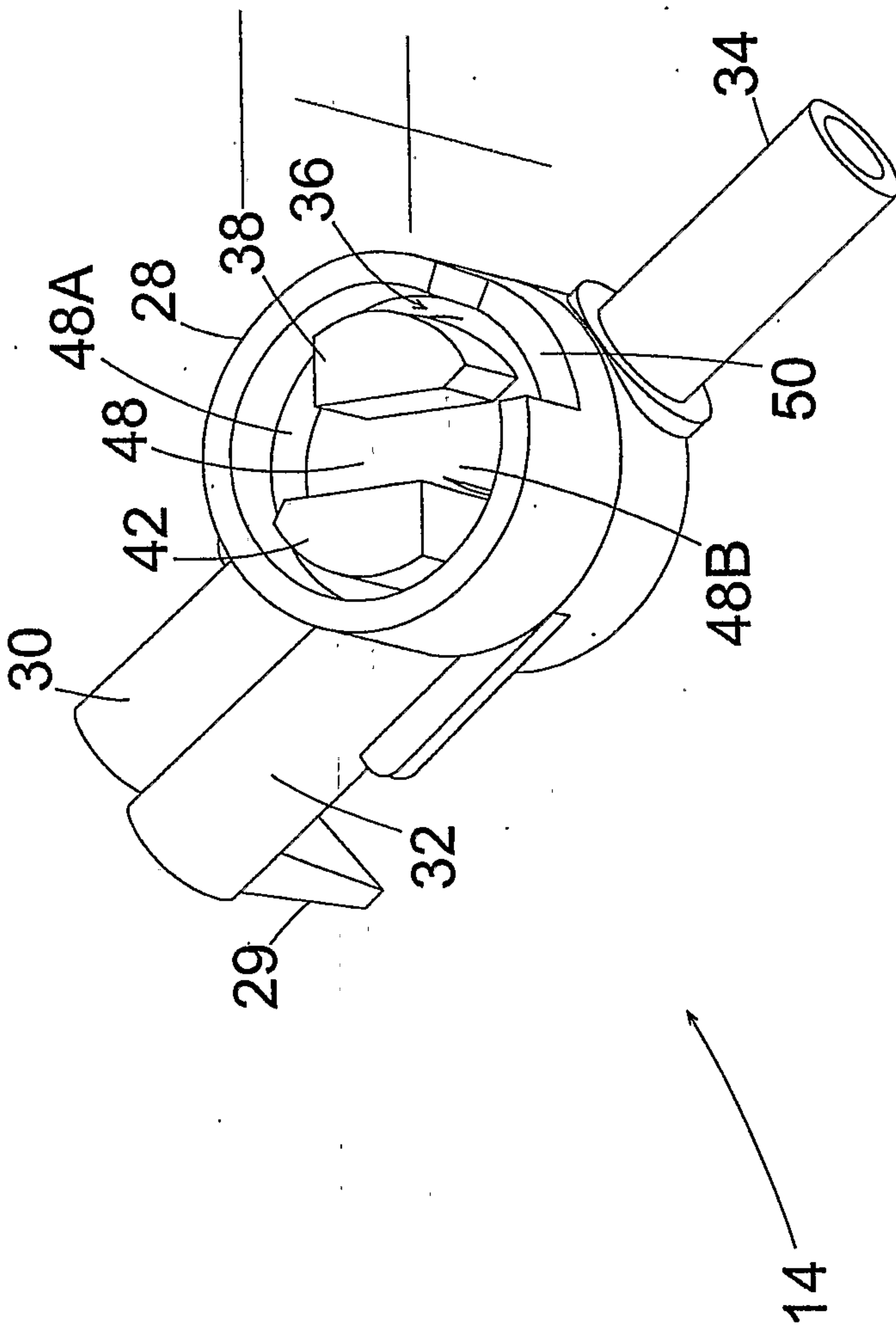

Fig. 3A

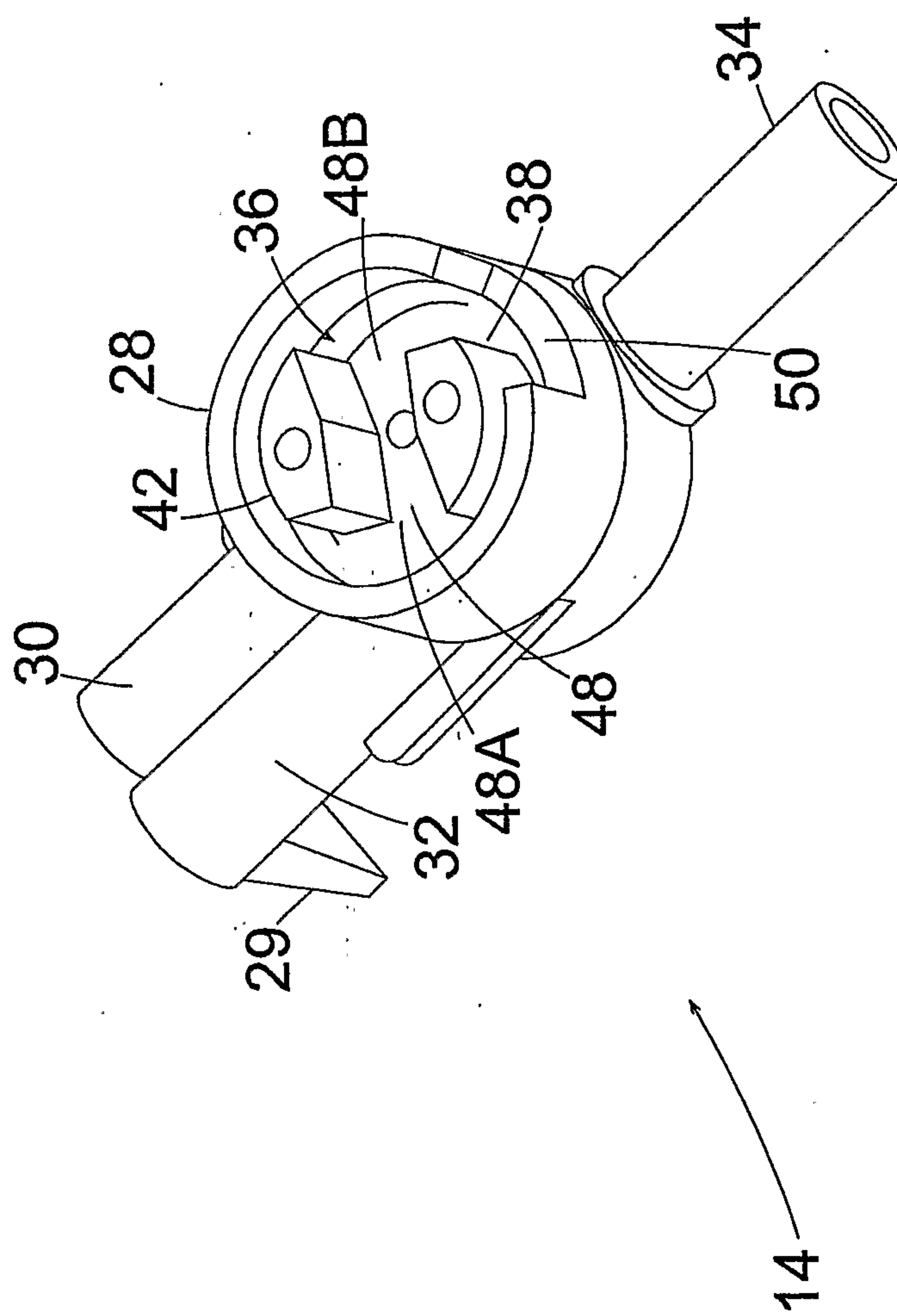

Fig. 3B

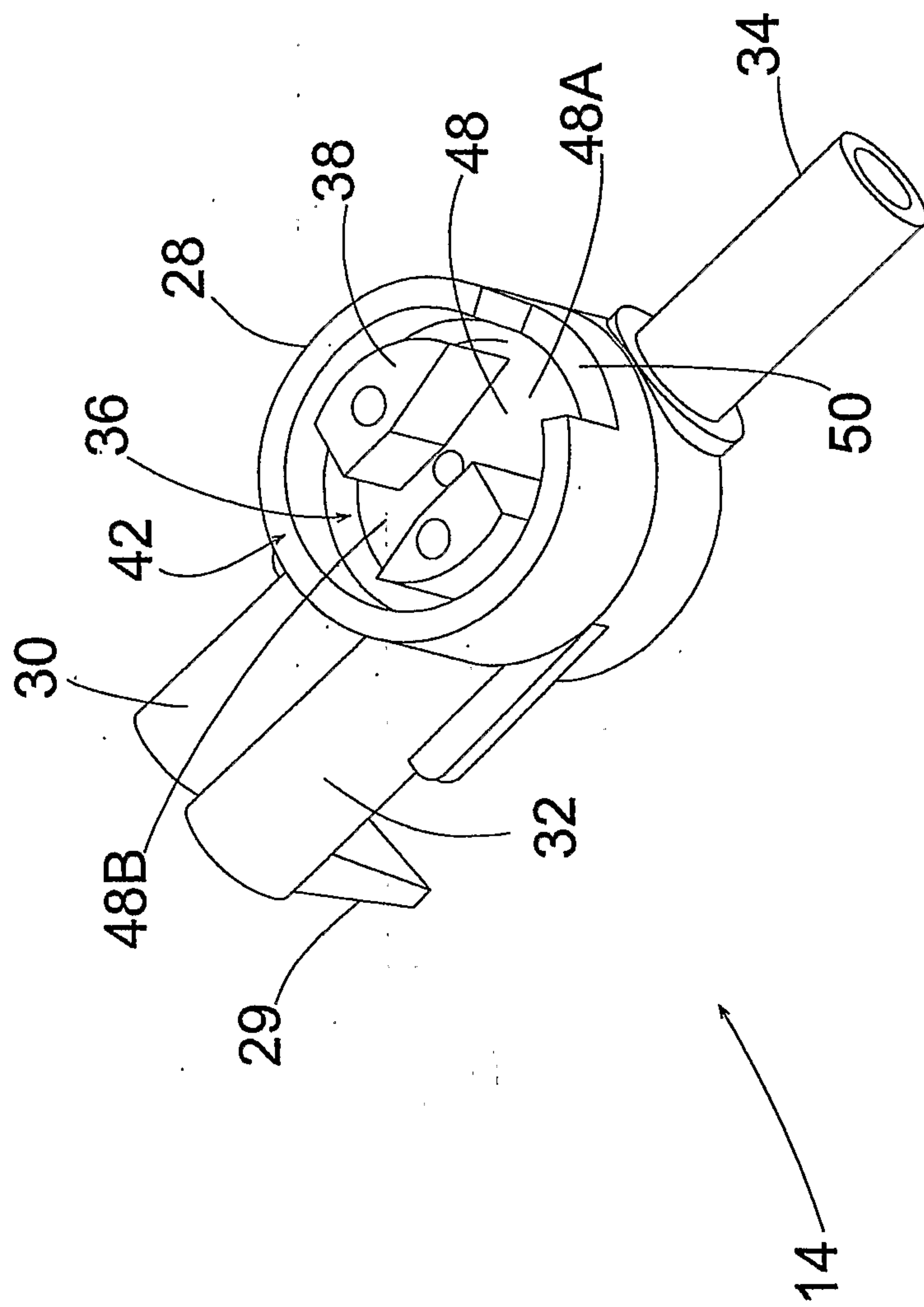

Fig. 3C

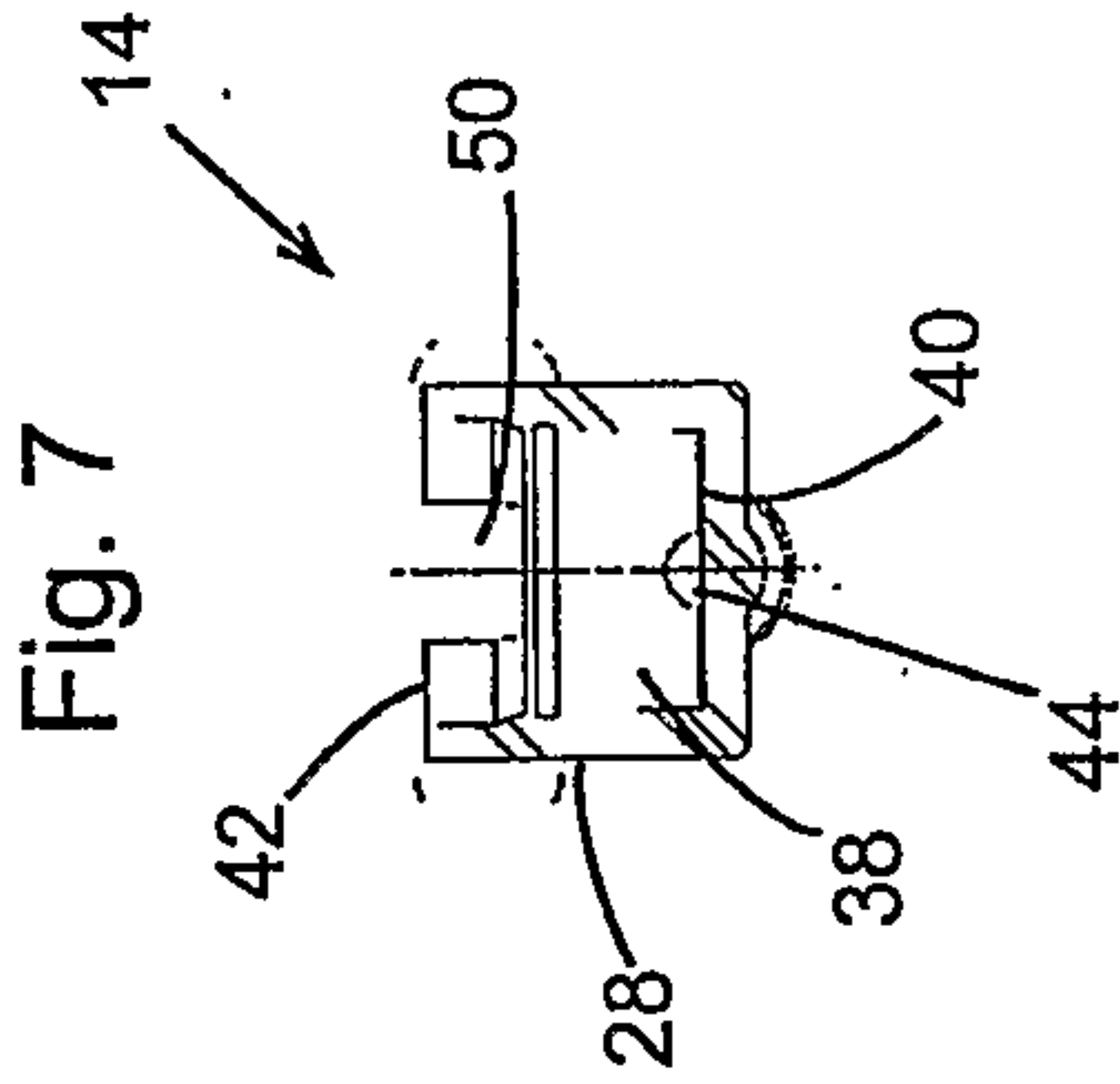

Fig. 7

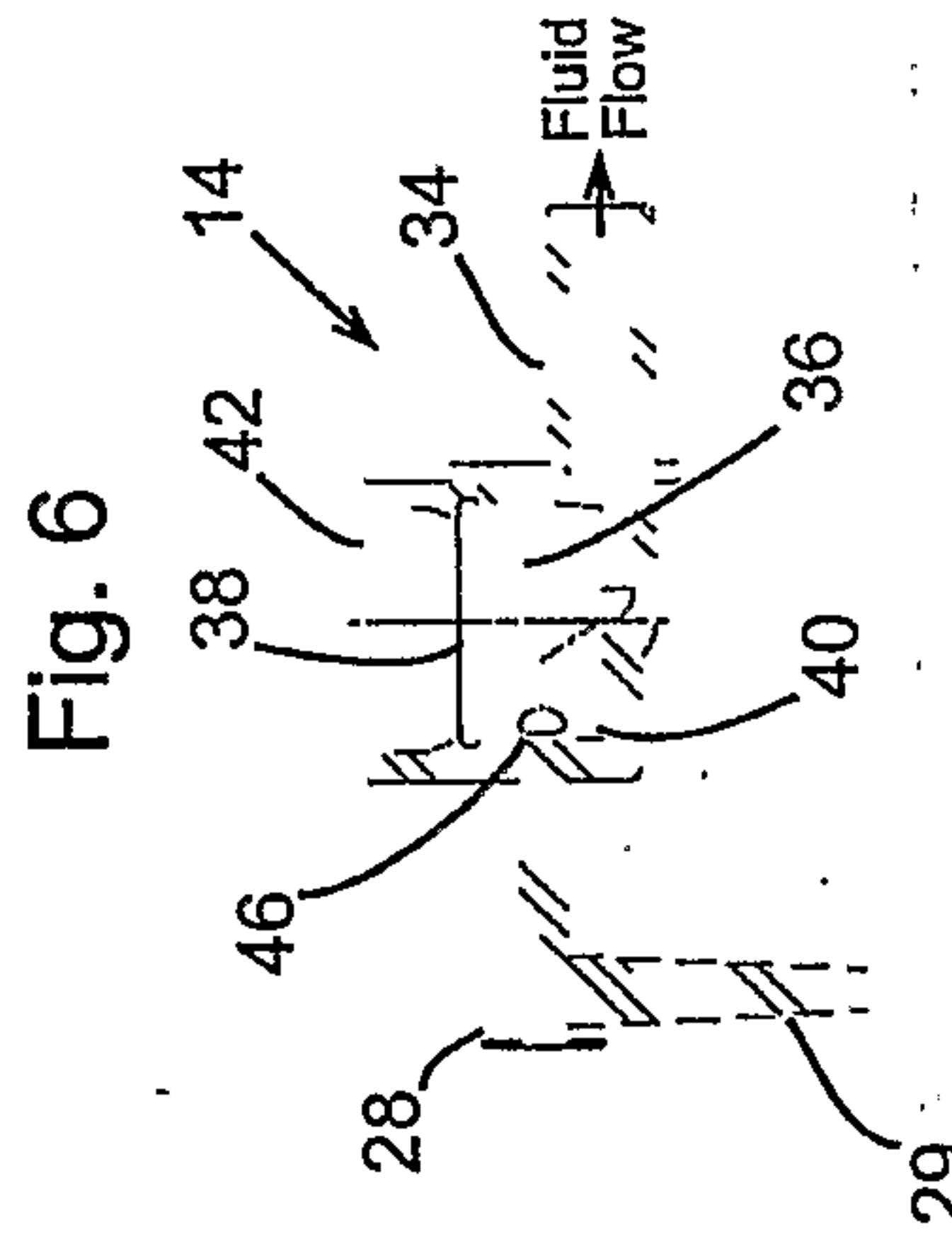

Fig. 6

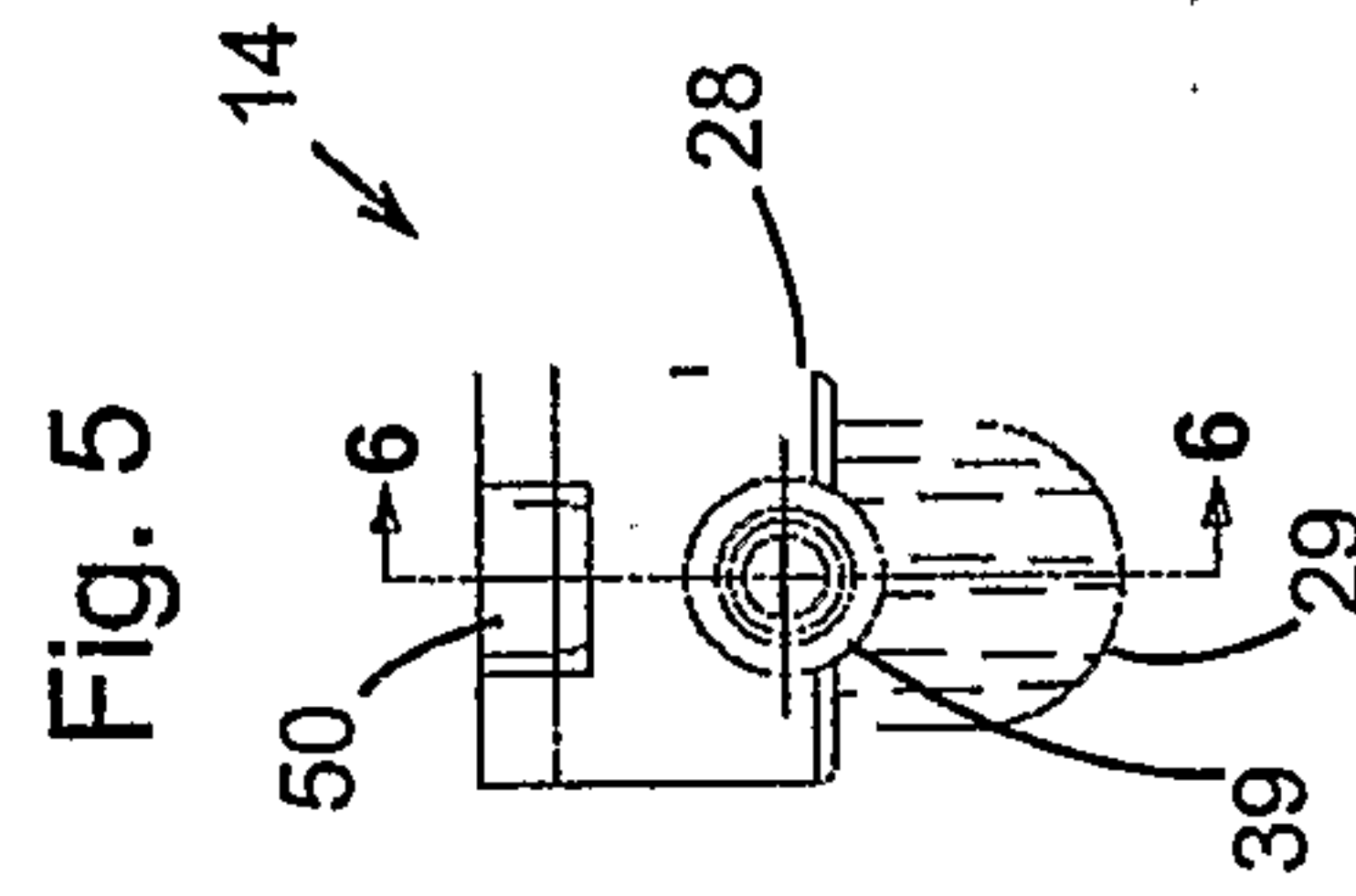

Fig. 5

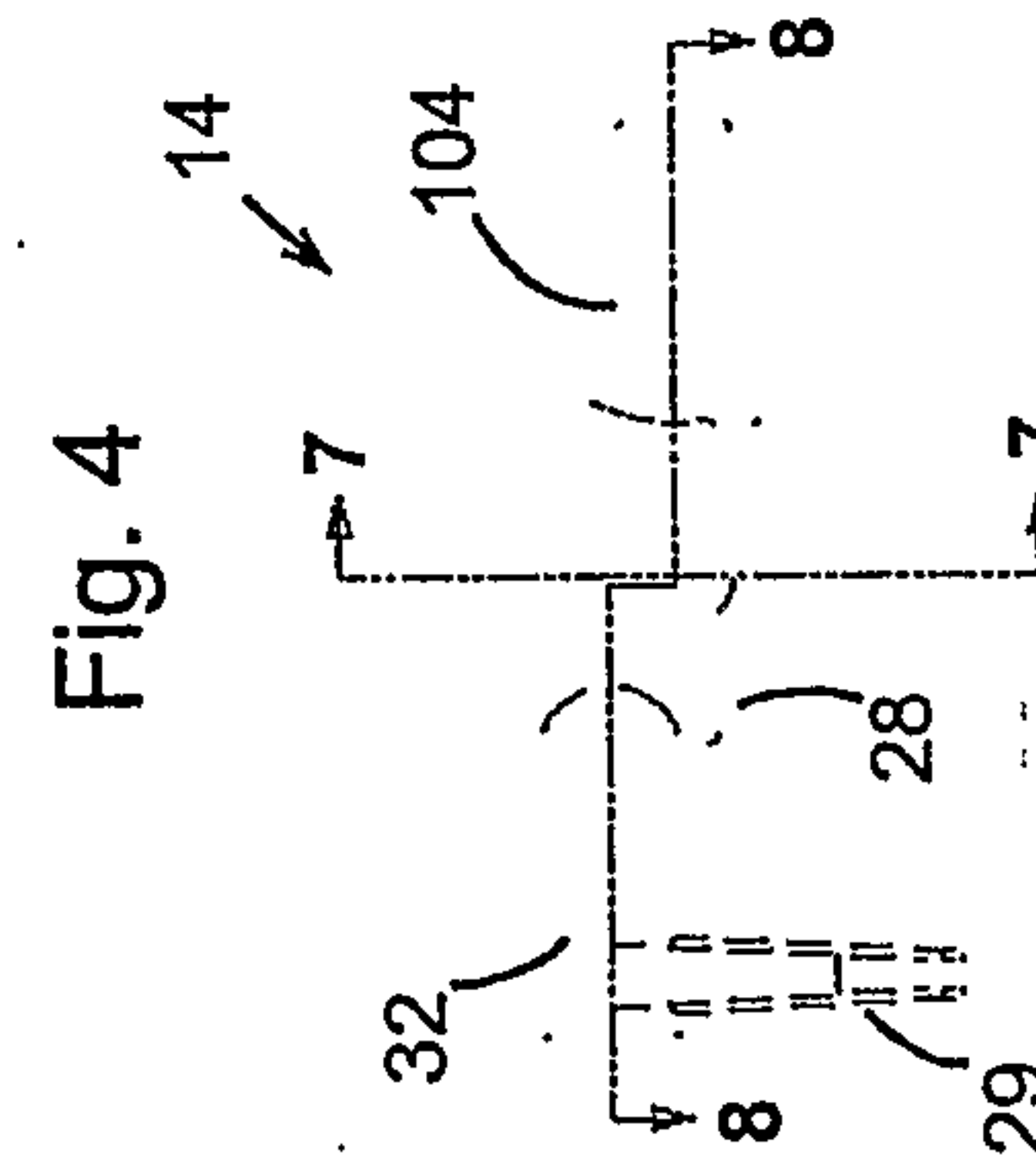

Fig. 4

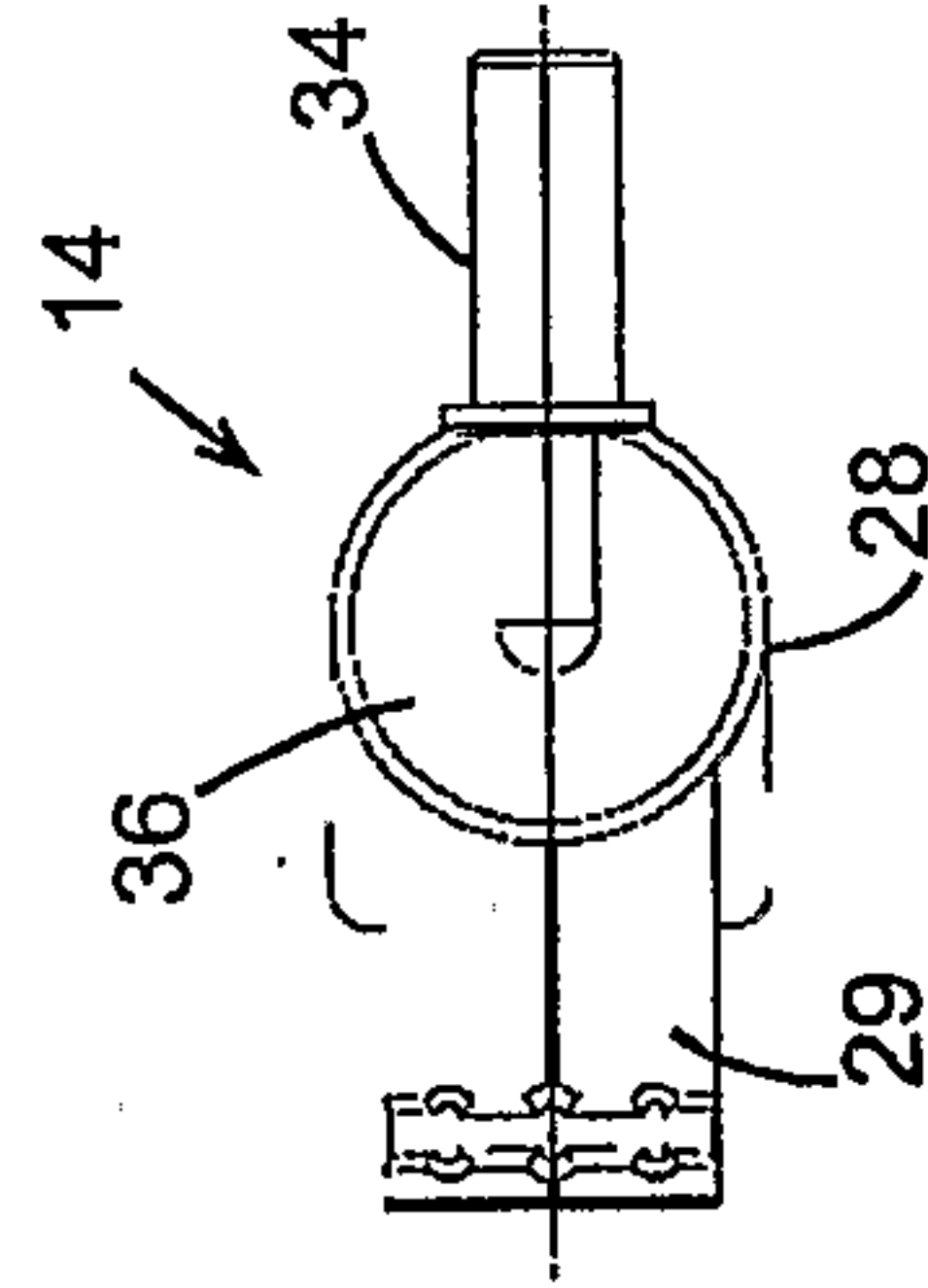

Fig. 10

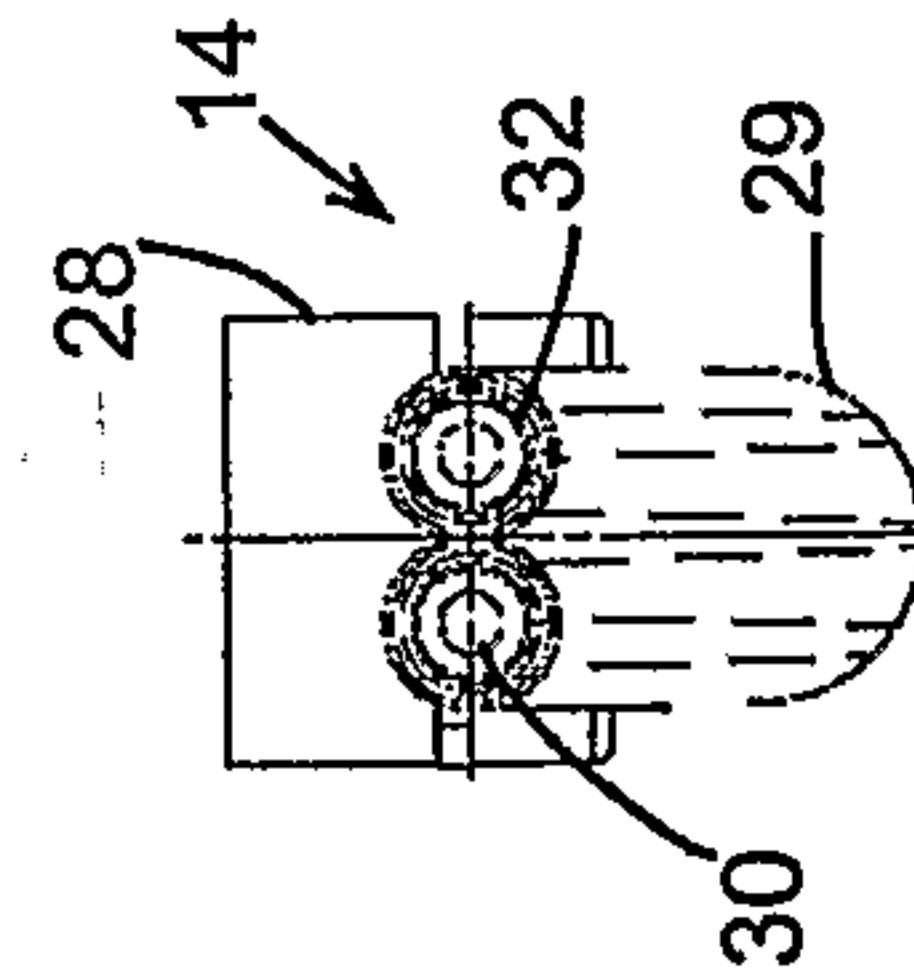

Fig. 9

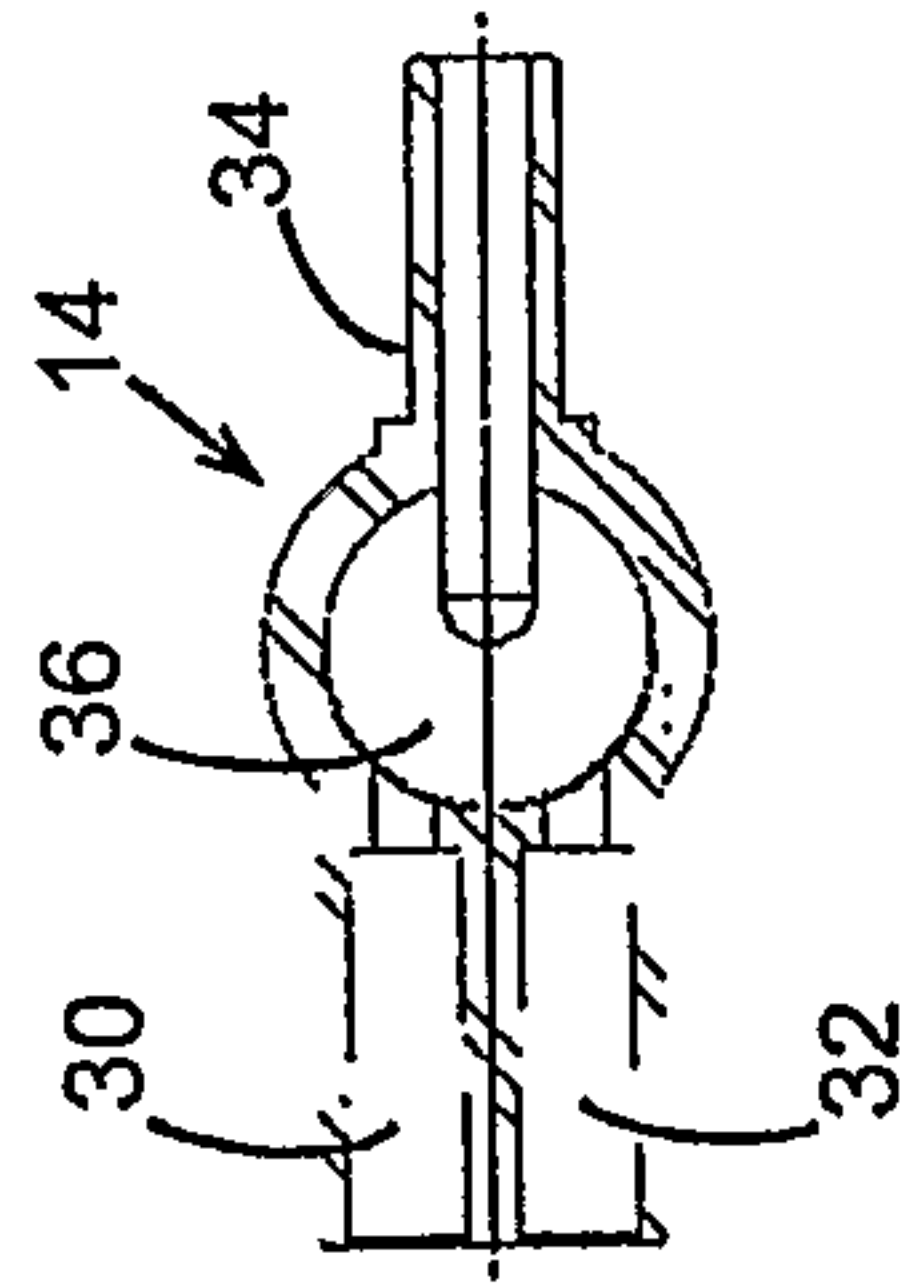

Fig. 8

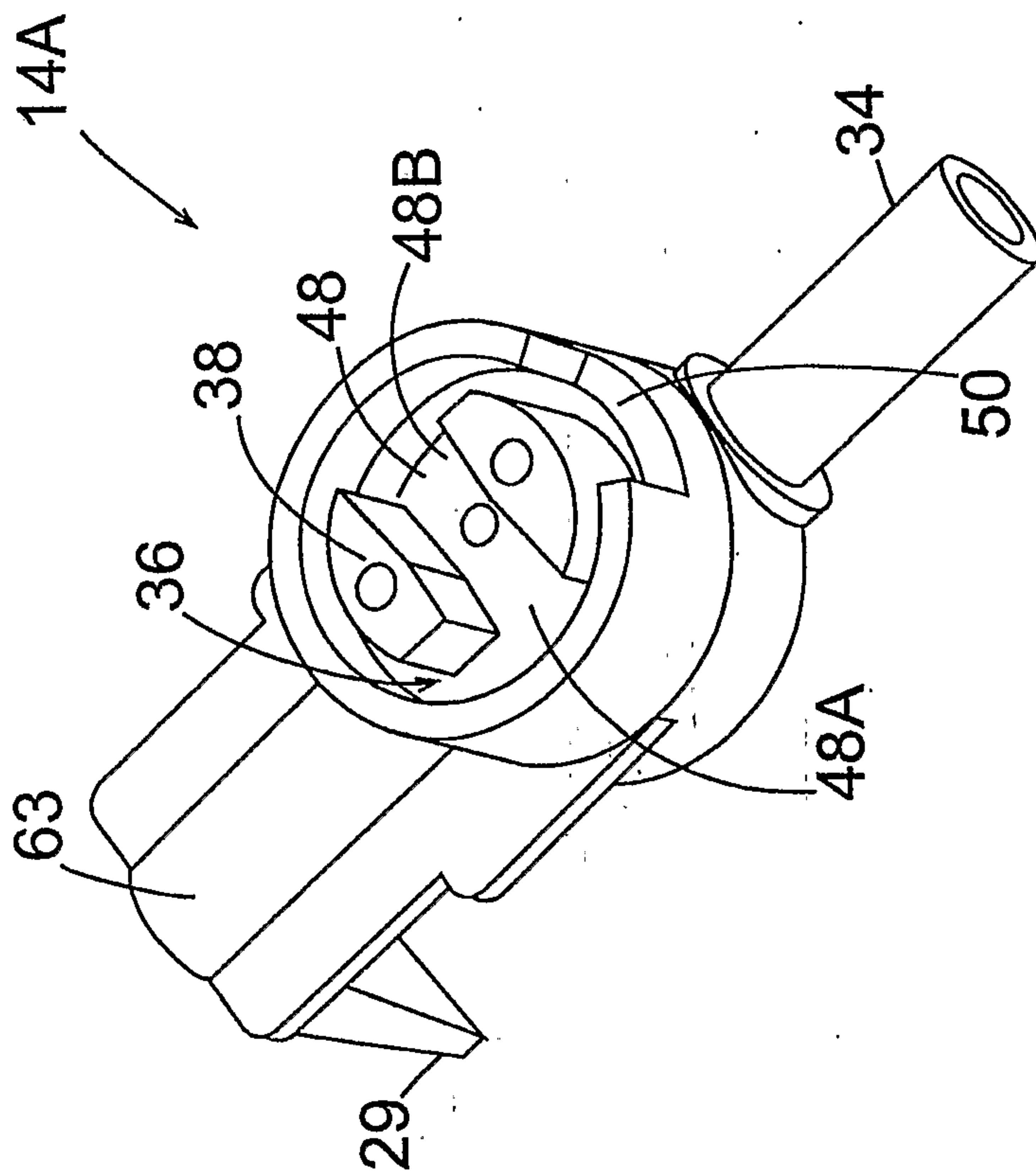

Fig. 11A

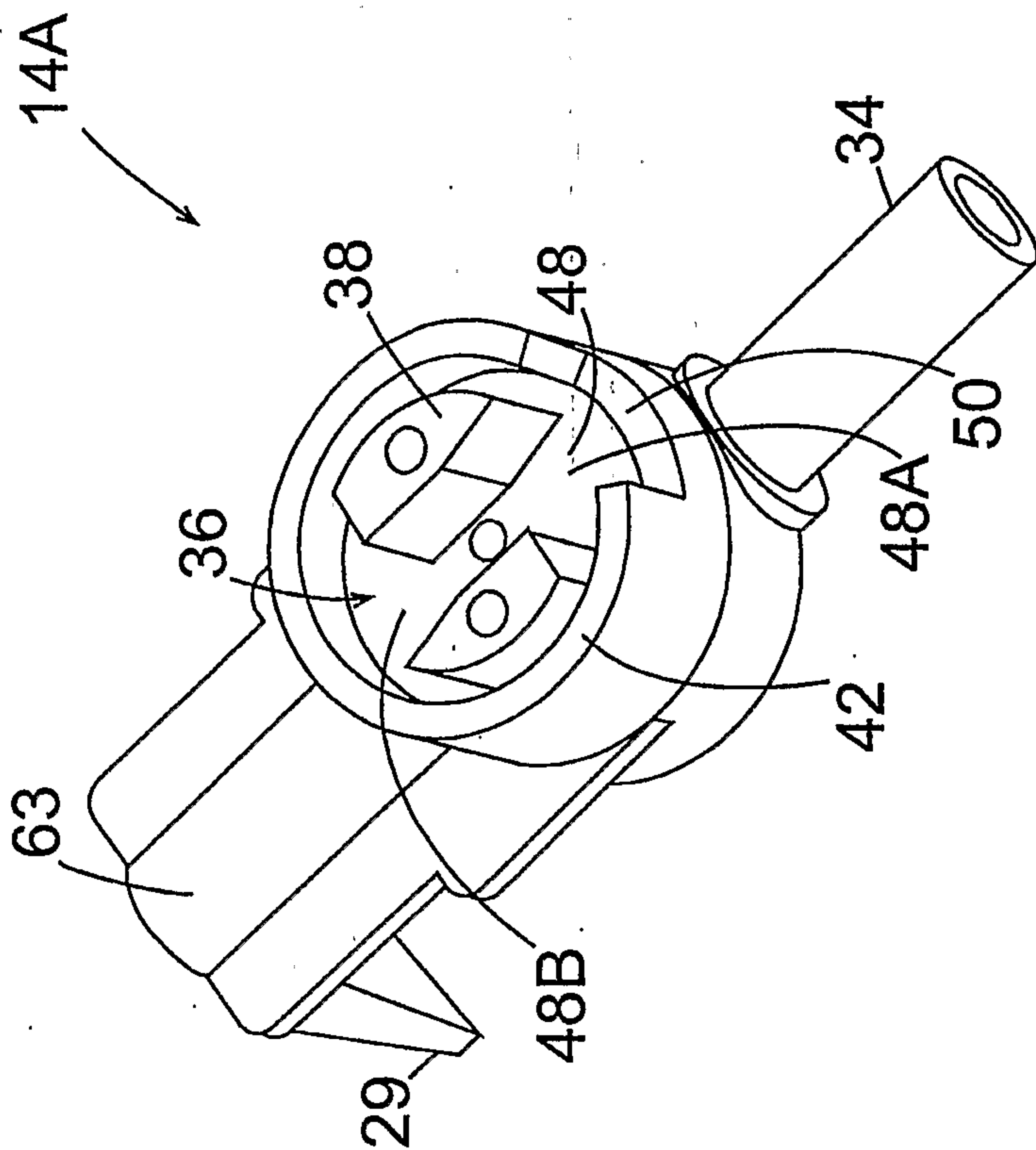

Fig. 11B

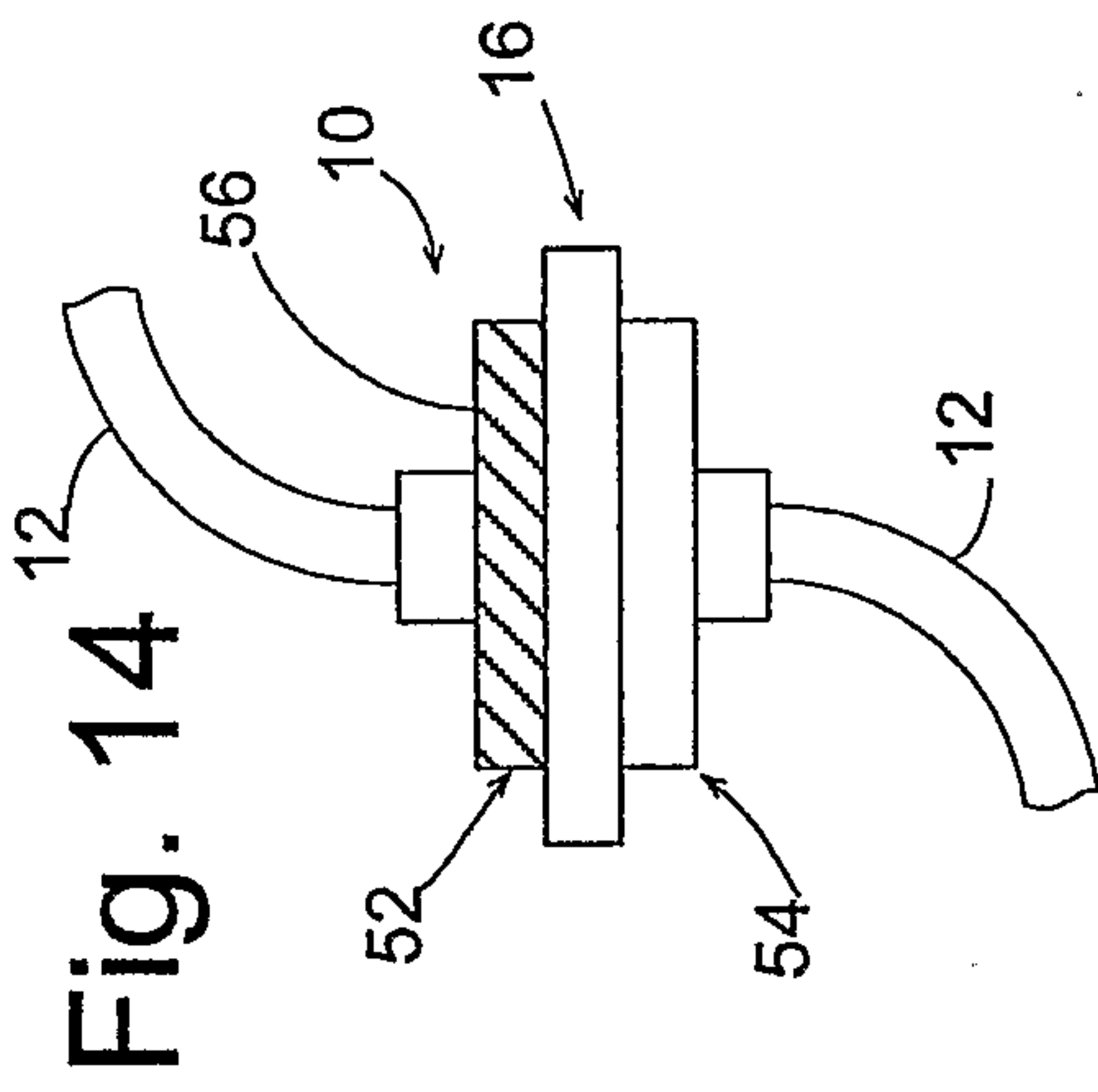

Fig. 12

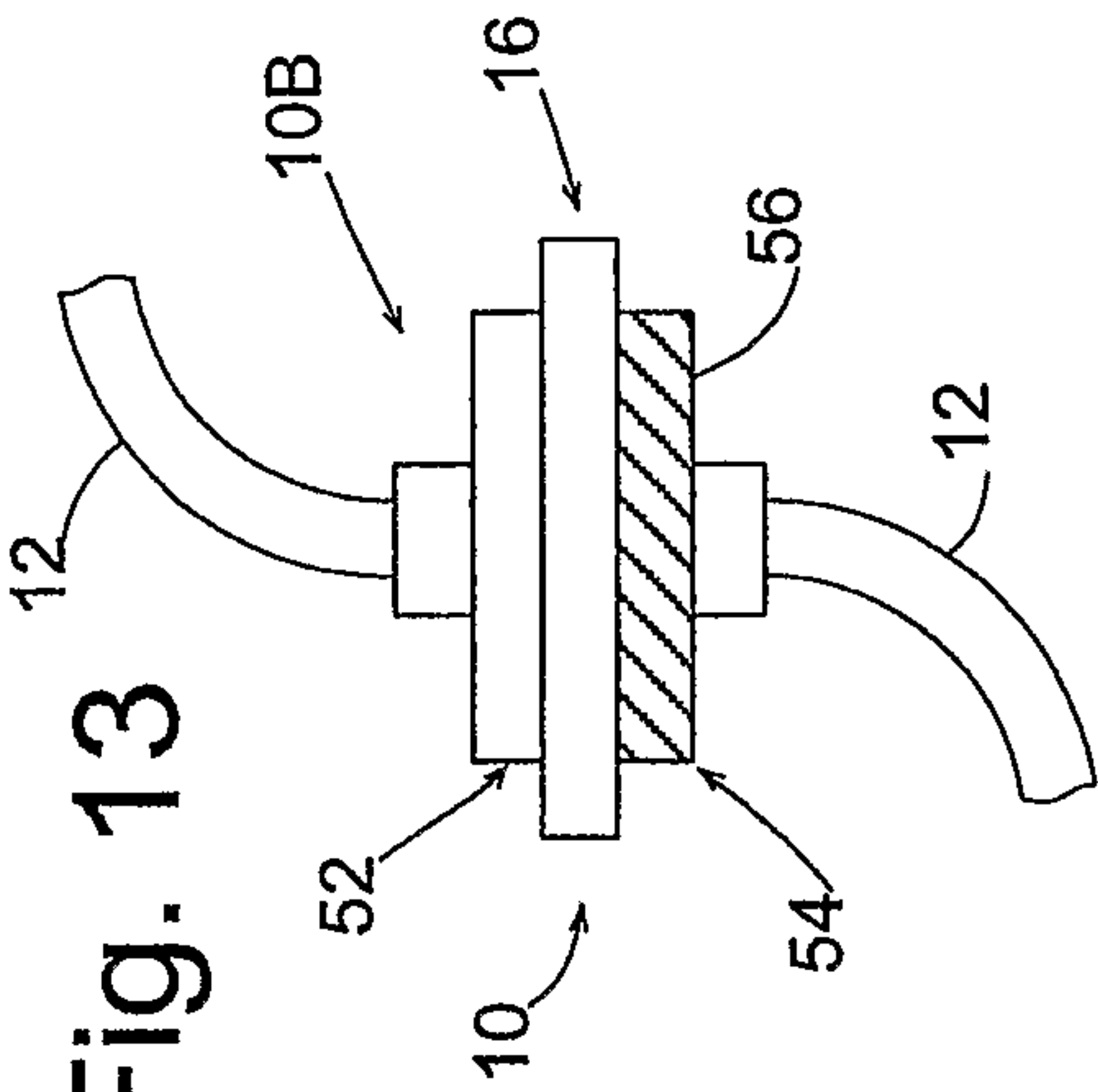

Fig. 13

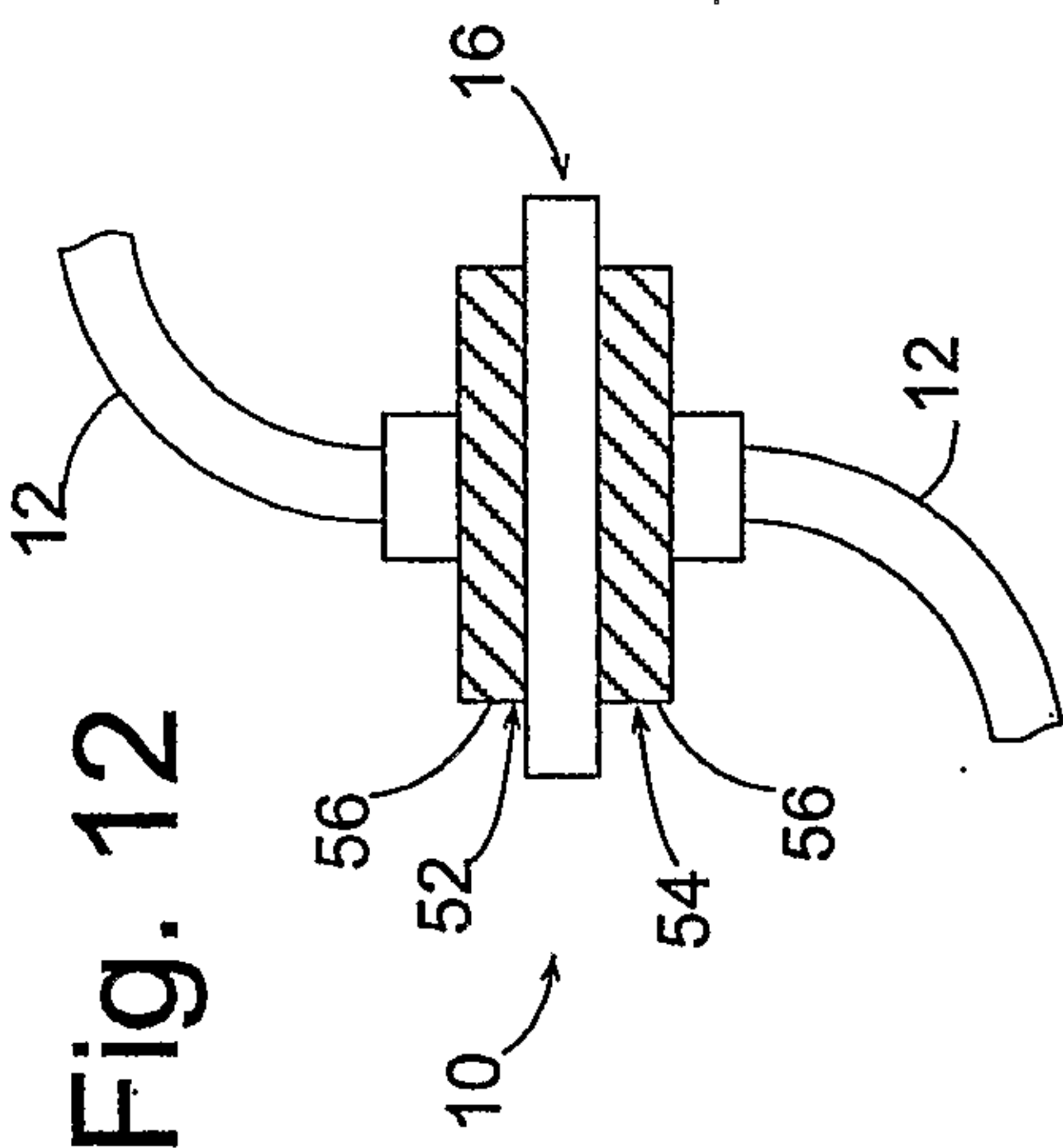

Fig. 14

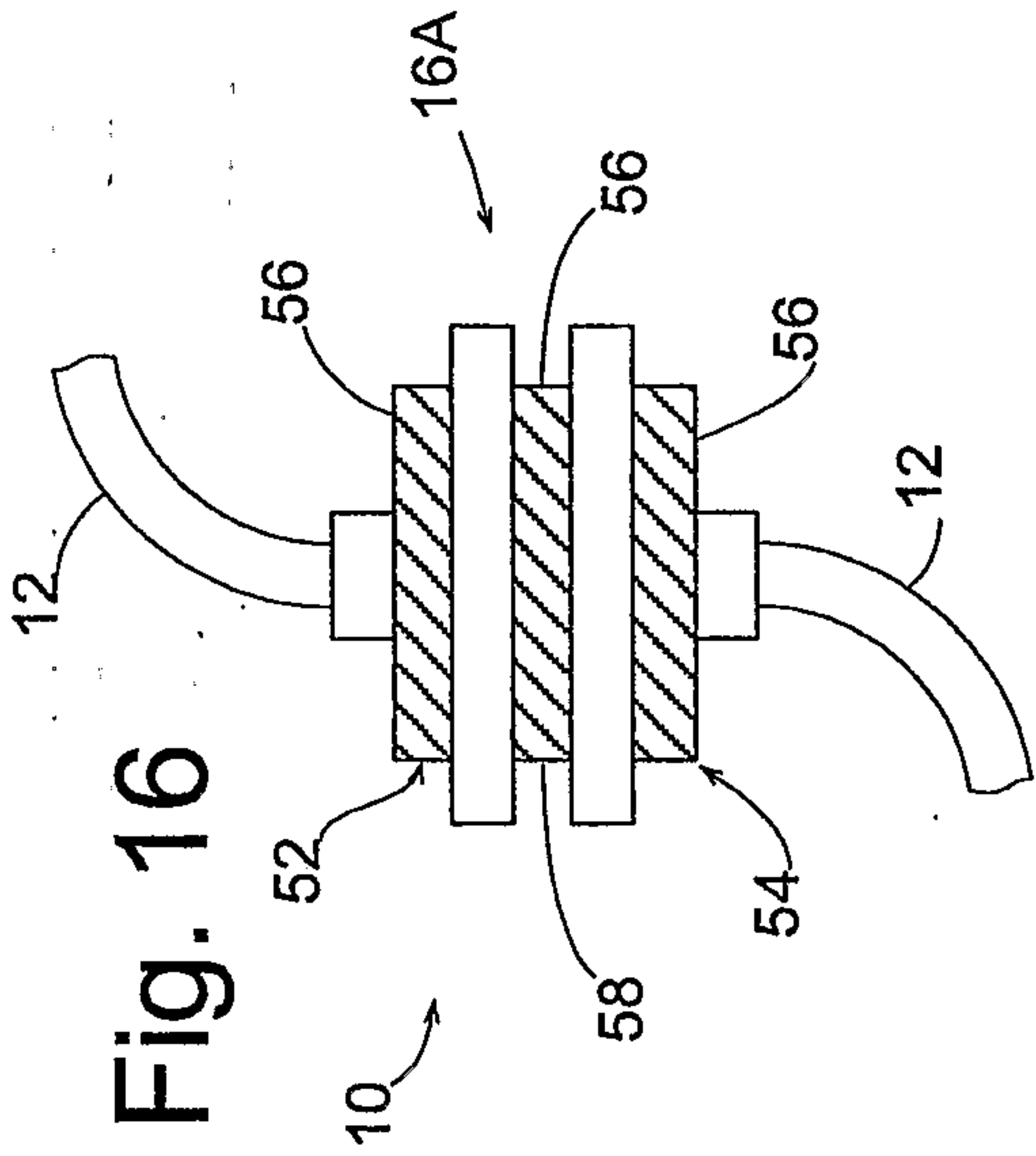

Fig. 15

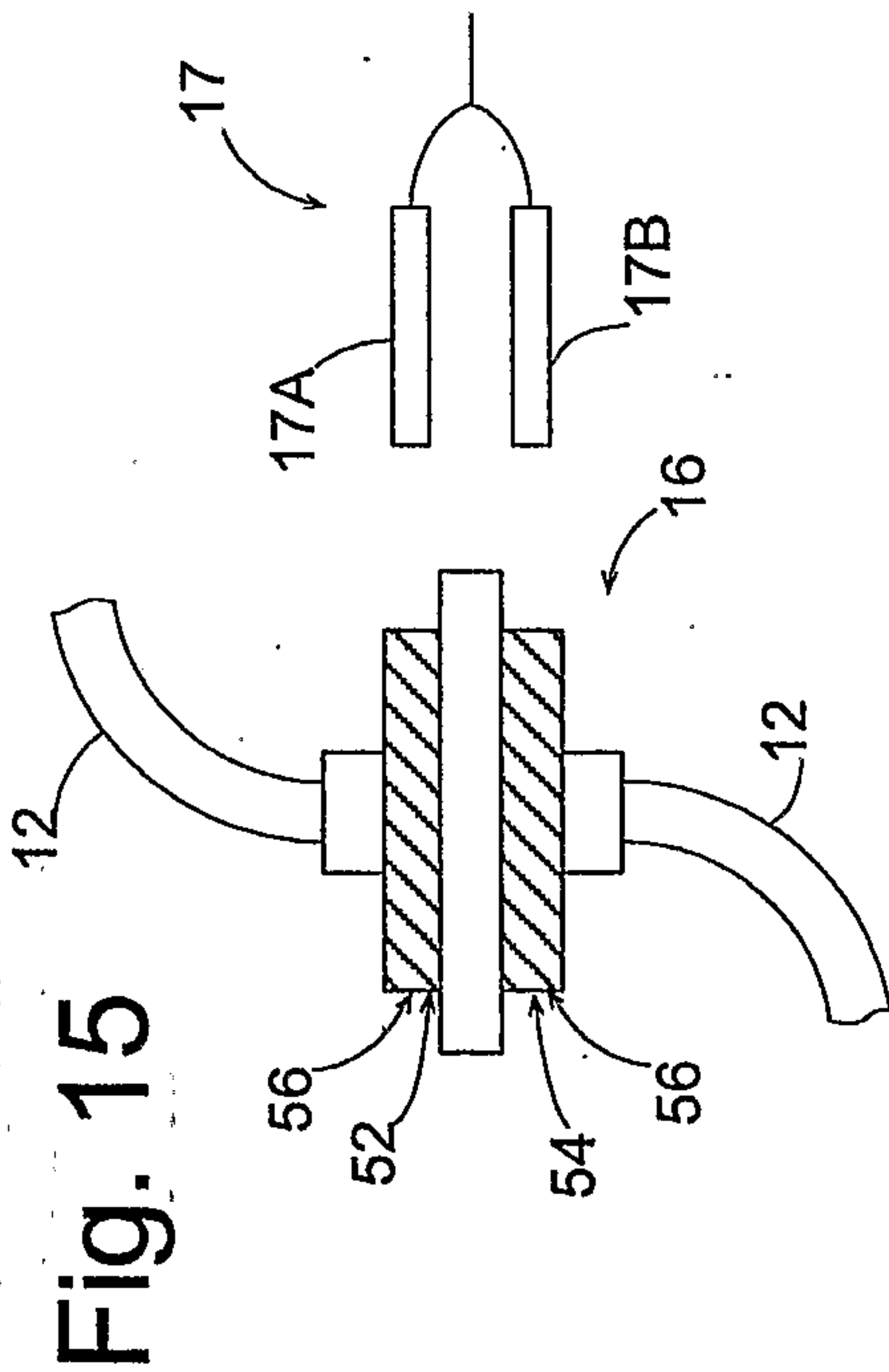
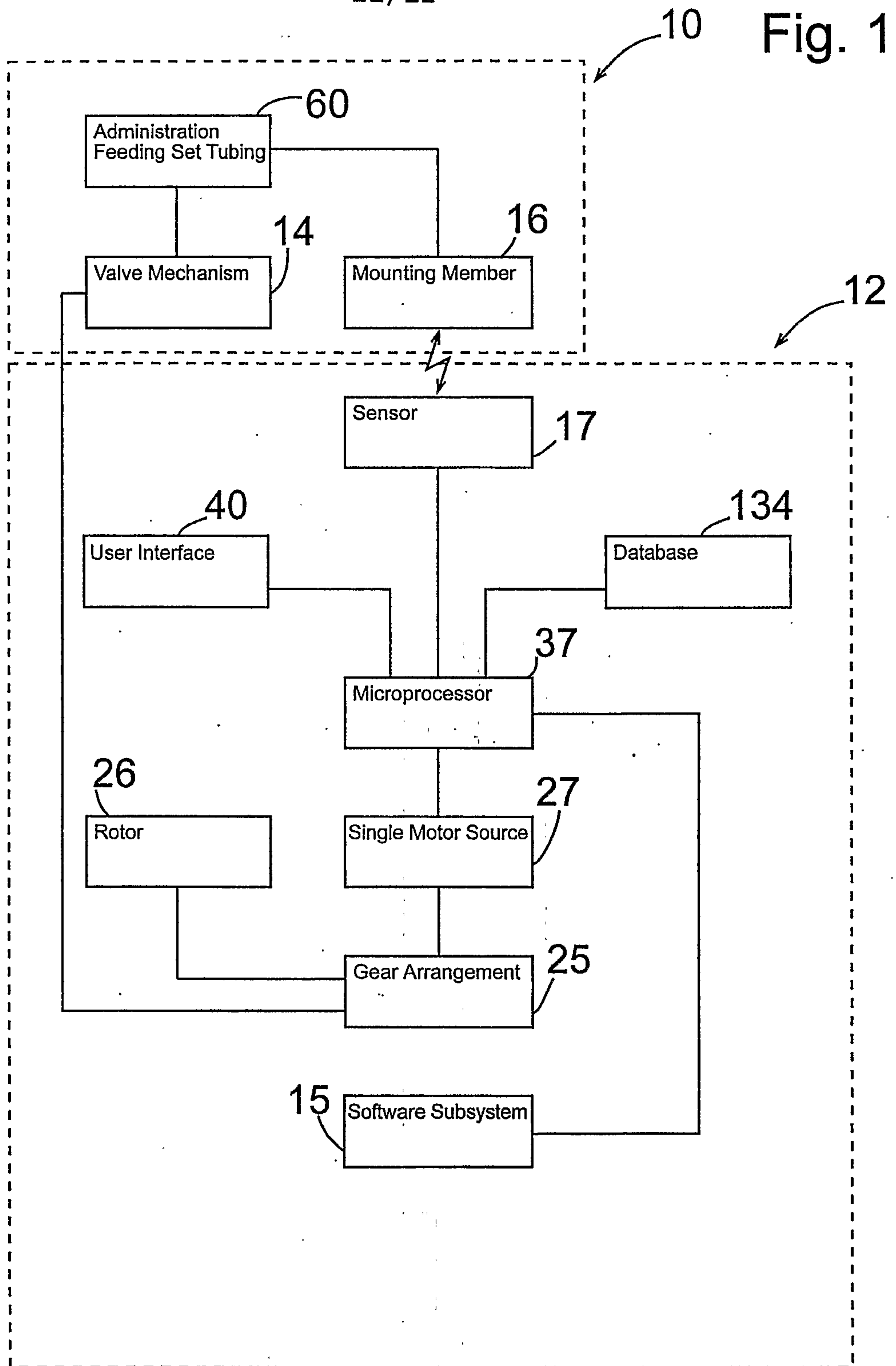

Fig. 16

Fig. 17



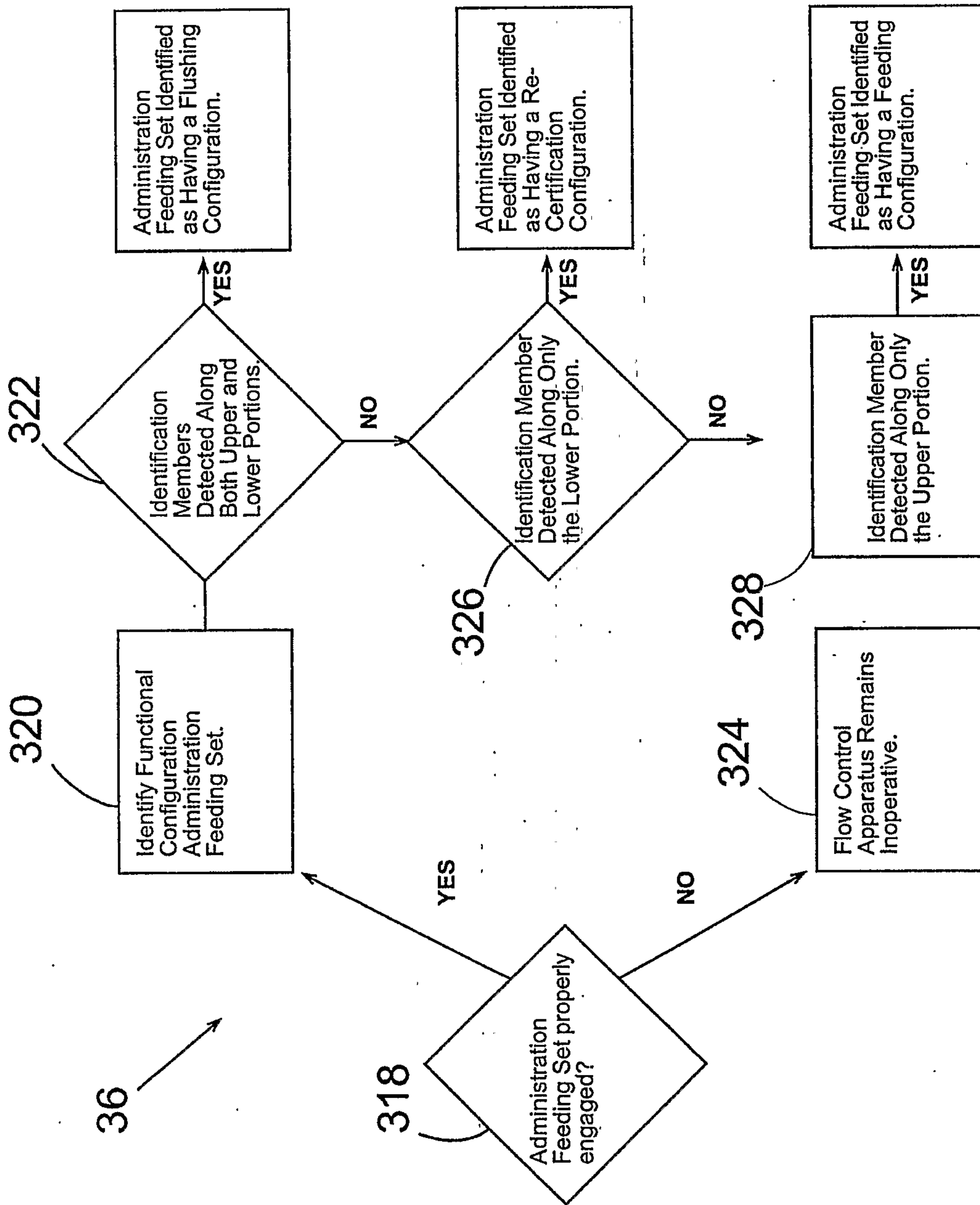

Fig. 18

From Feeding
Fluid Source

From Flushing
Fluid Source

To Patient

