



(12) **United States Patent**
Morton et al.

(10) **Patent No.:** **US 9,958,569 B2**
(45) **Date of Patent:** ***May 1, 2018**

(54) **MOBILE IMAGING SYSTEM AND METHOD FOR DETECTION OF CONTRABAND**

(71) Applicant: **Rapiscan Systems, Inc.**, Torrance, CA (US)

(72) Inventors: **Edward James Morton**, Guildford (GB); **Andreas F. Kotowski**, Rancho Palos Verdes, CA (US)

(73) Assignee: **Rapiscan Systems, Inc.**, Torrance, CA (US)

(*) Notice: Subject to any disclaimer, the term of this patent is extended or adjusted under 35 U.S.C. 154(b) by 0 days. days.
This patent is subject to a terminal disclaimer.

(21) Appl. No.: **14/556,927**

(22) Filed: **Dec. 1, 2014**

(65) **Prior Publication Data**
US 2015/0168589 A1 Jun. 18, 2015

Related U.S. Application Data
(63) Continuation of application No. 13/864,440, filed on Apr. 17, 2013, now Pat. No. 8,929,509, which is a (Continued)

(51) **Int. Cl.**
G01V 5/00 (2006.01)
G01N 23/04 (2018.01)
G01N 23/203 (2006.01)

(52) **U.S. Cl.**
CPC **G01V 5/0066** (2013.01); **G01N 23/04** (2013.01); **G01N 23/203** (2013.01); (Continued)

(58) **Field of Classification Search**
CPC G01N 23/04; G01N 2223/639; G01N 23/203; G01N 23/02; G01N 2223/419; (Continued)

(56) **References Cited**
U.S. PATENT DOCUMENTS
2,831,123 A 4/1958 Daly
2,972,430 A * 2/1961 Johnson B65D 9/18 220/1.5
(Continued)

FOREIGN PATENT DOCUMENTS
EP 0261984 A2 3/1988
EP 0864884 A2 9/1998
(Continued)

OTHER PUBLICATIONS
International Search Report and Written Opinion for PCT/US2010/041757, dated Oct. 12, 2010.
(Continued)

Primary Examiner — Irakli Kiknadze
(74) *Attorney, Agent, or Firm* — Novel IP

(57) **ABSTRACT**
The present invention provides a four-sided scanning system for vehicles that uses a combination of backscatter and transmission based X-ray imaging to achieve material discrimination. In one embodiment, the system is designed as a mobile, drive-through system, which can be folded and stowed in a truck and can be conveniently deployed at any place when required.

20 Claims, 10 Drawing Sheets

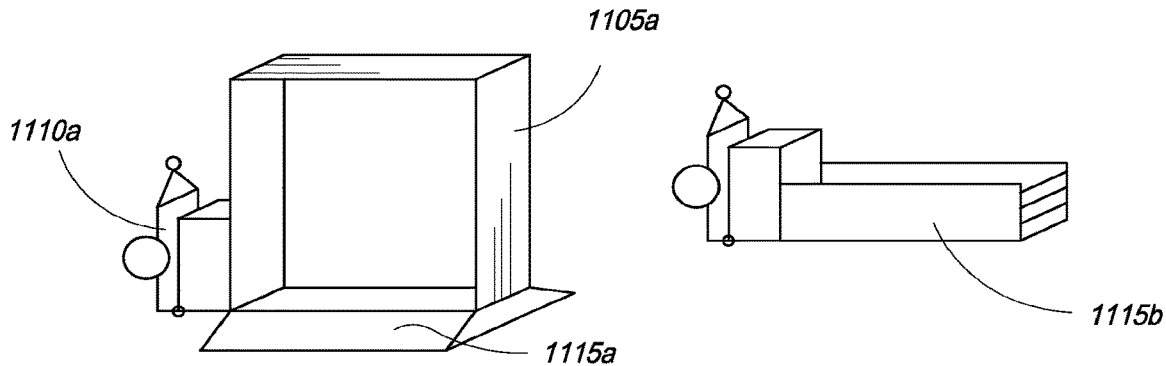

Related U.S. Application Data

(56)

References Cited

continuation of application No. 12/834,890, filed on Jul. 12, 2010, now Pat. No. 8,503,605, which is a continuation-in-part of application No. 12/784,630, filed on May 21, 2010, now Pat. No. 8,275,091, said application No. 12/834,890 is a continuation-in-part of application No. 12/853,976, filed on Apr. 5, 2010, now Pat. No. 7,995,705, which is a continuation-in-part of application No. 12/349,534, filed on Jan. 7, 2009, now Pat. No. 7,720,195, which is a continuation of application No. 10/939,986, filed on Sep. 13, 2004, now Pat. No. 7,486,768, which is a continuation-in-part of application No. 10/915,687, filed on Aug. 9, 2004, now Pat. No. 7,322,745, which is a continuation-in-part of application No. 10/201,543, filed on Jul. 23, 2002, now Pat. No. 6,843,599, said application No. 12/834,890 is a continuation-in-part of application No. 12/396,568, filed on Mar. 3, 2009, now Pat. No. 7,817,776, which is a continuation-in-part of application No. 11/948,814, filed on Nov. 30, 2007, now Pat. No. 7,517,149, which is a continuation of application No. 10/915,687, filed on Aug. 9, 2004, now Pat. No. 7,322,745, said application No. 12/834,890 is a continuation-in-part of application No. 12/395,760, filed on Mar. 2, 2009, now Pat. No. 7,876,880, which is a continuation of application No. 12/051,910, filed on Mar. 20, 2008, now Pat. No. 7,519,148, which is a continuation of application No. 11/622,560, filed on Jan. 12, 2007, now Pat. No. 7,369,643, said application No. 12/834,890 is a continuation-in-part of application No. 12/339,591, filed on Dec. 19, 2008, now Pat. No. 7,963,695, said application No. 12/834,890 is a continuation-in-part of application No. 12/263,160, filed on Oct. 31, 2008, now Pat. No. 7,783,004, said application No. 12/834,890 is a continuation-in-part of application No. 12/675,471, filed as application No. PCT/GB2008/002897 on Aug. 29, 2008, now abandoned.

(60) Provisional application No. 61/180,471, filed on May 22, 2009, provisional application No. 61/224,938, filed on Jul. 13, 2009, provisional application No. 60/493,935, filed on Aug. 8, 2003, provisional application No. 61/014,814, filed on Dec. 19, 2007, provisional application No. 60/984,786, filed on Nov. 2, 2007.

(52) **U.S. Cl.**
CPC *G01V 5/0016* (2013.01); *G01V 5/0025* (2013.01); *G01V 5/0041* (2013.01)

(58) **Field of Classification Search**
CPC G01N 23/046; G01N 23/06; G01N 23/20; G01N 2223/1016; G01N 2223/30; G01N 2223/3307; G01N 2223/423; G01N 2223/64; G01N 2223/643; G01N 23/005; G01N 23/00; G01V 5/0016; G01V 5/0025; G01V 5/0041; G01V 5/0066; G01V 5/0008; G01V 5/0033; G01V 5/0075; G01V 5/005; G01V 5/0083; G01V 5/0058; G01V 11/00; G01V 3/08; G01V 3/105; G01V 3/165; H05G 1/02; H05G 1/52; H05G 2/00; G21K 1/04; G21K 1/093; G21K 1/062
USPC 378/57, 62, 145, 153, 160, 98.8
See application file for complete search history.

U.S. PATENT DOCUMENTS

3,766,387 A	10/1973	Heffan	
3,784,837 A	1/1974	Holmstrom	
RE28,544 E	9/1975	Stein	
3,961,186 A	6/1976	Leunbach	
4,047,035 A	9/1977	Dennhoven	
4,064,440 A	12/1977	Roder	
4,139,771 A	2/1979	Dennhoven	
4,210,811 A	7/1980	Dennhoven	
4,216,499 A	8/1980	Dennhoven	
4,366,382 A	12/1982	Kotowski	
4,380,817 A	4/1983	Harding	
4,420,182 A *	12/1983	Kaneshiro	B60R 9/10 296/158
4,430,568 A	2/1984	Yoshida	
4,525,854 A	6/1985	Molbert	
4,566,113 A	1/1986	Doenges	
4,599,740 A	7/1986	Cable	
4,641,330 A	2/1987	Herwig	
4,736,401 A	4/1988	Donges	
4,788,704 A	11/1988	Donges	
4,799,247 A	1/1989	Annis	
4,809,312 A	2/1989	Annis	
4,825,454 A	4/1989	Annis	
4,864,142 A	9/1989	Gomberg	
4,870,670 A	9/1989	Geus	
4,884,289 A	11/1989	Glockmann	
4,979,202 A	12/1990	Siczek	
4,991,189 A	2/1991	Boomgaarden	
5,022,062 A	6/1991	Annis	
5,065,418 A *	11/1991	Bermbach	G01V 5/0016 250/358.1
5,091,924 A	2/1992	Bermbach	
5,098,640 A	3/1992	Gozani	
5,179,581 A	1/1993	Annis	
5,181,234 A	1/1993	Smith	
5,182,764 A	1/1993	Peschmann	
5,224,144 A	6/1993	Annis	
5,237,598 A	8/1993	Albert	
5,247,561 A	9/1993	Kotowski	
5,253,283 A	10/1993	Annis	
5,313,511 A	5/1994	Annis	
5,367,552 A	11/1994	Peschmann	
5,379,334 A	1/1995	Zimmer	
5,394,454 A	2/1995	Harding	
5,430,787 A	7/1995	Norton	
5,493,596 A	2/1996	Annis	
5,600,303 A	2/1997	Husseiny	
5,638,420 A	6/1997	Armistead	
5,642,393 A	6/1997	Krug	
5,642,394 A	6/1997	Rothschild	
5,666,393 A	9/1997	Annis	
5,687,210 A	11/1997	Maitrejean	
5,692,028 A	11/1997	Geus	
5,692,029 A	11/1997	Husseiny	
5,696,806 A	12/1997	Grodzins	
5,751,837 A	5/1998	Watanabe	
5,763,886 A	6/1998	Schulte	
5,764,683 A	6/1998	Swift	
5,768,334 A	6/1998	Maitrejean	
5,787,145 A	7/1998	Geus	
5,805,660 A	9/1998	Perion	
5,838,759 A	11/1998	Armistead	
5,903,623 A	5/1999	Swift	
5,910,973 A	6/1999	Grodzins	
5,930,326 A	7/1999	Rothschild	
5,940,468 A	8/1999	Huang	
5,974,111 A	10/1999	Krug	
6,018,562 A	1/2000	Willson	
6,031,890 A	2/2000	Bermbach	
6,058,158 A	5/2000	Eiler	
6,067,344 A	5/2000	Grodzins	
6,081,580 A	6/2000	Grodzins	
6,094,472 A	7/2000	Smith	
6,151,381 A	11/2000	Grodzins	
6,188,747 B1	2/2001	Geus	

(56)

References Cited

U.S. PATENT DOCUMENTS

6,192,101 B1 2/2001 Grodzins
 6,192,104 B1 2/2001 Adams
 6,195,413 B1 2/2001 Geus
 6,198,795 B1 3/2001 Naumann
 6,212,251 B1 4/2001 Tomura
 6,218,943 B1 4/2001 Ellenbogen
 6,236,709 B1 5/2001 Perry
 6,249,567 B1 6/2001 Rothschild
 6,252,929 B1 6/2001 Swift
 6,256,369 B1 7/2001 Lai
 6,278,115 B1 8/2001 Annis
 6,282,260 B1 8/2001 Grodzins
 6,292,533 B1 9/2001 Swift
 6,301,326 B2 10/2001 Bjorkholm
 6,320,933 B1 11/2001 Grodzins
 6,356,620 B1 3/2002 Rothschild
 6,421,420 B1 7/2002 Grodzins
 6,424,695 B1 7/2002 Grodzins
 6,434,219 B1 8/2002 Rothschild
 6,435,715 B1 8/2002 Betz
 6,442,233 B1 8/2002 Grodzins
 6,445,765 B1 9/2002 Frank
 6,453,003 B1 9/2002 Springer
 6,453,007 B2 9/2002 Adams
 6,456,684 B1 9/2002 Mun
 6,459,761 B1* 10/2002 Grodzins G01N 23/02
 378/56
 6,459,764 B1 10/2002 Chalmers
 6,473,487 B1 10/2002 Le
 RE37,899 E 11/2002 Grodzins
 6,483,894 B2 11/2002 Hartick
 6,507,025 B1 1/2003 Verbinski
 6,532,276 B1 3/2003 Hartick
 6,542,574 B2 4/2003 Grodzins
 6,542,578 B2 4/2003 Ries
 6,542,580 B1* 4/2003 Carver G01V 5/0008
 378/57
 6,543,599 B2 4/2003 Jasinetzky
 6,546,072 B1 4/2003 Chalmers
 6,552,346 B2 4/2003 Verbinski
 6,556,653 B2 4/2003 Hussein
 6,563,903 B2 5/2003 Kang
 6,567,496 B1 5/2003 Sychev
 6,580,778 B2 6/2003 Meder
 6,584,170 B2 6/2003 Aust
 6,597,760 B2 7/2003 Beneke
 6,606,516 B2 8/2003 Levine
 6,636,581 B2 10/2003 Sorenson
 6,653,588 B1 11/2003 Gillard-Hickman
 6,658,087 B2 12/2003 Chalmers
 6,663,280 B2 12/2003 Doenges
 6,665,373 B1 12/2003 Kotowski
 6,665,433 B2 12/2003 Roder
 6,763,635 B1 7/2004 Lowman
 6,785,357 B2 8/2004 Bernardi
 6,812,426 B1 11/2004 Kotowski
 6,816,571 B2 11/2004 Bijjani
 6,837,422 B1 1/2005 Meder
 6,839,403 B1 1/2005 Kotowski
 6,843,599 B2 1/2005 Le
 6,876,719 B2 4/2005 Ozaki
 6,879,657 B2 4/2005 Hoffman
 6,920,197 B2 7/2005 Kang
 7,039,159 B2 5/2006 Muenchau
 7,099,434 B2 8/2006 Adams
 7,103,137 B2 9/2006 Seppi
 RE39,396 E 11/2006 Swift
 7,162,005 B2 1/2007 Bjorkholm
 7,203,276 B2 4/2007 Arsenault
 7,207,713 B2 4/2007 Lowman
 7,218,704 B1 5/2007 Adams
 7,322,745 B2 1/2008 Agrawal
 7,333,587 B2 2/2008 De
 7,369,463 B1 5/2008 Van Dullemen

7,379,530 B2 5/2008 Hoff
 7,400,701 B1 7/2008 Cason
 7,486,768 B2 2/2009 Allman
 7,505,556 B2 3/2009 Chalmers
 7,517,149 B2 4/2009 Agrawal
 7,519,148 B2 4/2009 Kotowski
 7,551,715 B2 6/2009 Rothschild
 7,555,099 B2 6/2009 Rothschild
 7,593,506 B2 9/2009 Cason
 7,593,510 B2* 9/2009 Rothschild G21K 1/043
 378/146
 7,720,195 B2 5/2010 Allman
 7,742,568 B2 6/2010 Smith
 7,783,004 B2 8/2010 Kotowski
 7,809,109 B2 10/2010 Mastronardi
 7,817,776 B2 10/2010 Agrawal
 7,876,880 B2 1/2011 Kotowski
 7,963,695 B2 6/2011 Kotowski
 7,995,705 B2 8/2011 Allman
 8,000,436 B2 8/2011 Seppi
 8,194,822 B2 6/2012 Rothschild
 8,275,091 B2 9/2012 Morton
 8,503,605 B2 8/2013 Morton
 8,929,509 B2* 1/2015 Morton et al. 378/57
 2004/0141584 A1 7/2004 Bernardi
 2007/0009088 A1 1/2007 Edic
 2008/0037707 A1 2/2008 Rothschild
 2009/0067575 A1 3/2009 Seppi
 2009/0086907 A1 4/2009 Smith
 2009/0116617 A1 5/2009 Mastronardi

FOREIGN PATENT DOCUMENTS

EP 1135700 3/2005
 EP 1254384 1/2008
 EP 2054741 5/2009
 EP 1733213 2/2010
 EP 2049888 5/2014
 GB 2150526 A * 7/1985 A61G 3/001
 GB 2277013 A 10/1994
 WO 1998002763 A1 1/1998
 WO 1998003889 A1 1/1998
 WO 1998020366 A1 5/1998
 WO 1999039189 A2 8/1999
 WO 2004010127 A1 1/2004
 WO 2009027667 A2 3/2009

OTHER PUBLICATIONS

Chou, C, "Fourier coded-aperture imaging in nuclear medicine", IEEE Proc. Sci. Meas. Technol., vol. 141. No. 3, May 1994, pp. 179-184.
 European Patent Office Summons to attend oral proceedings pursuant to Rule 115(1) EPC, Application No. 05743513.3-2204/1733213, dated May 6, 2009, 3 pages.
 European Patent Office, International Search Report and Written Opinion of the International Searching Authority, PCT/US2005/011382, dated Oct. 21, 2005.
 European Patent Office, International Search Report, International Application No. PCT/US99/28266, dated Sep. 6, 2000, 3 pages.
 International Search Report, PCT/US2007/066936; dated Sep. 30, 2008, 5 pages.
 International Search Report, PCT/US1998/18642, dated Jul. 7, 1999, 4 pages.
 International Search Report, PCT/US1999/028035, dated Sep. 15, 2000, 6 pages.
 Written Opinion of the International Searching Authority, PCT/US2007/066936, dated Sep. 30, 2008, 7 pages.
 International Bureau of WIPO, International Preliminary Report on Patentability, PCT/US2005/011382, dated Oct. 19, 2006, 7 pages.
 Mertz, L.N., et al, "Rotational aperture synthesis for x rays", Journal. Optical Society of America, vol. 3, Dec. 1986, pp. 2167-2170.

* cited by examiner

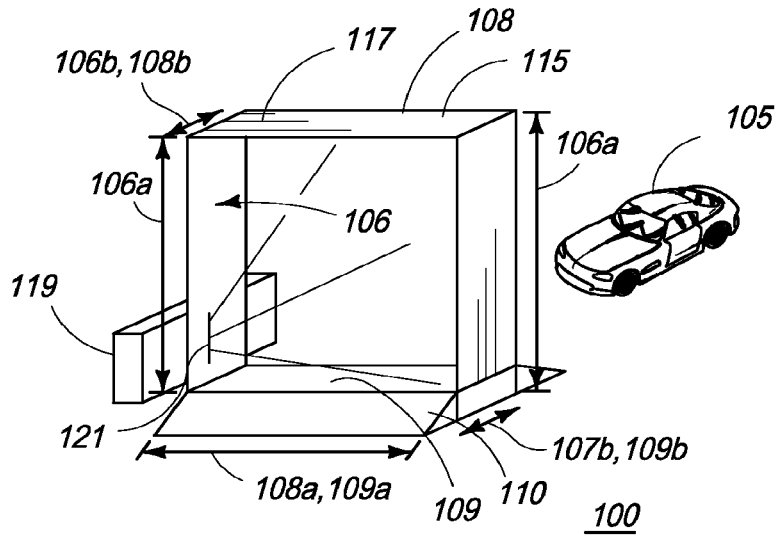

FIG. 1

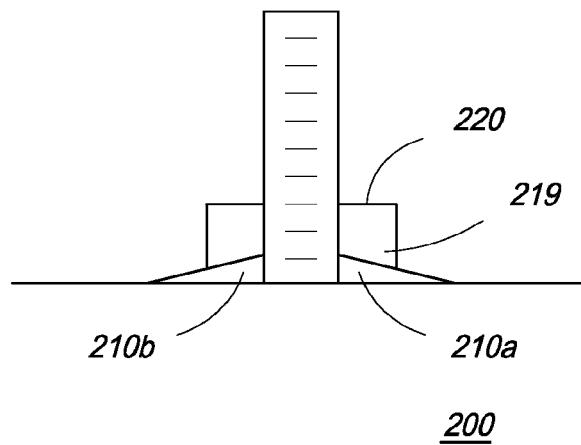
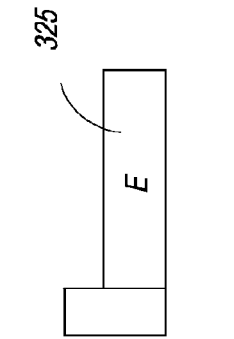
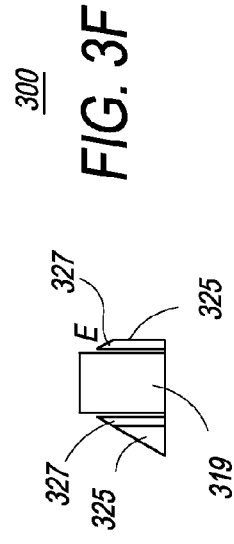
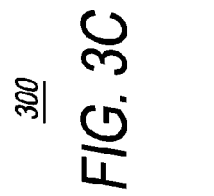
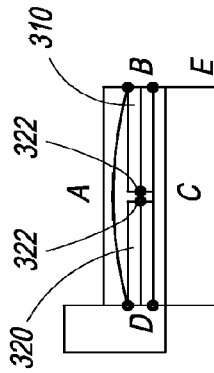
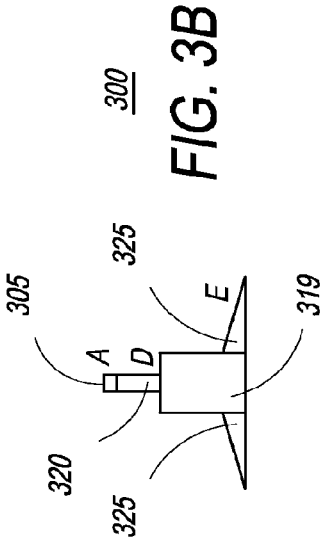

FIG. 2



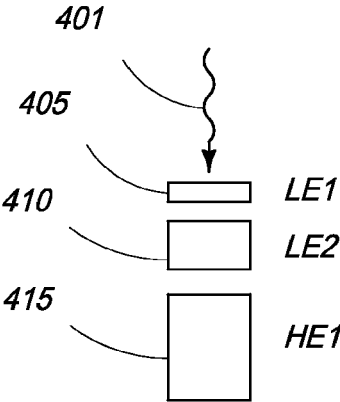

FIG. 4

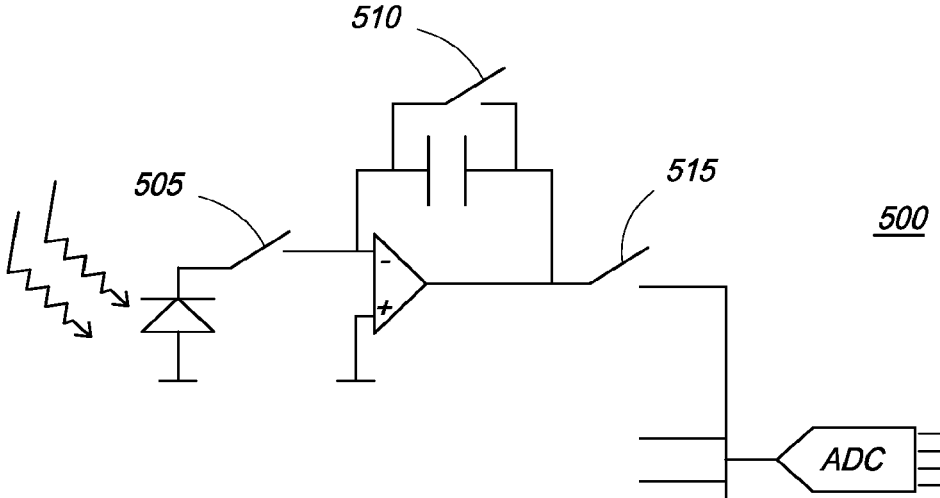

FIG. 5

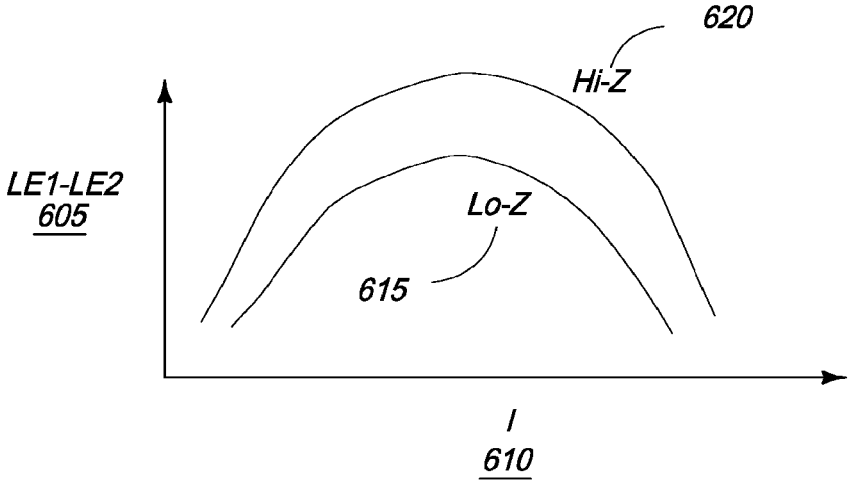

FIG. 6A

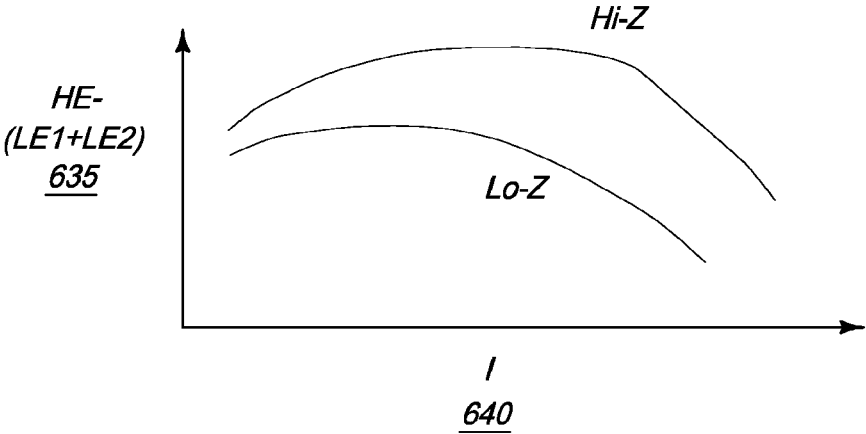

FIG. 6B

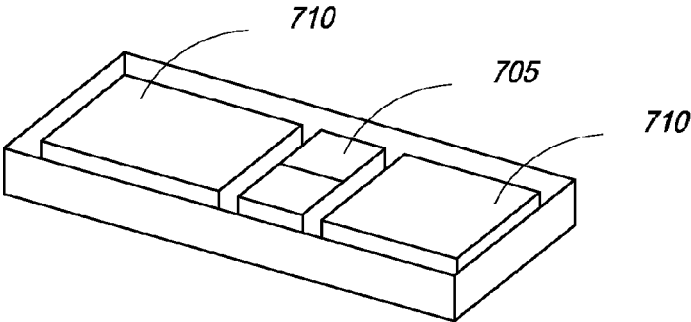

FIG. 7

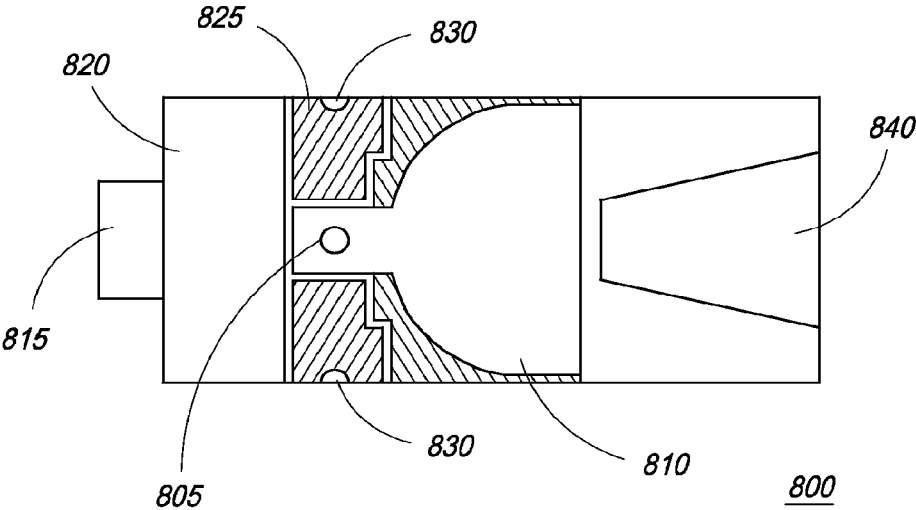

FIG. 8

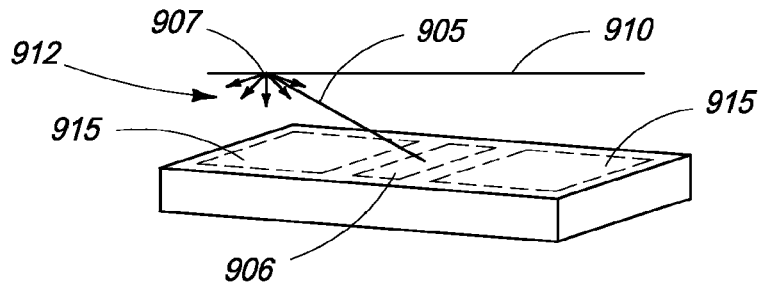

FIG. 9

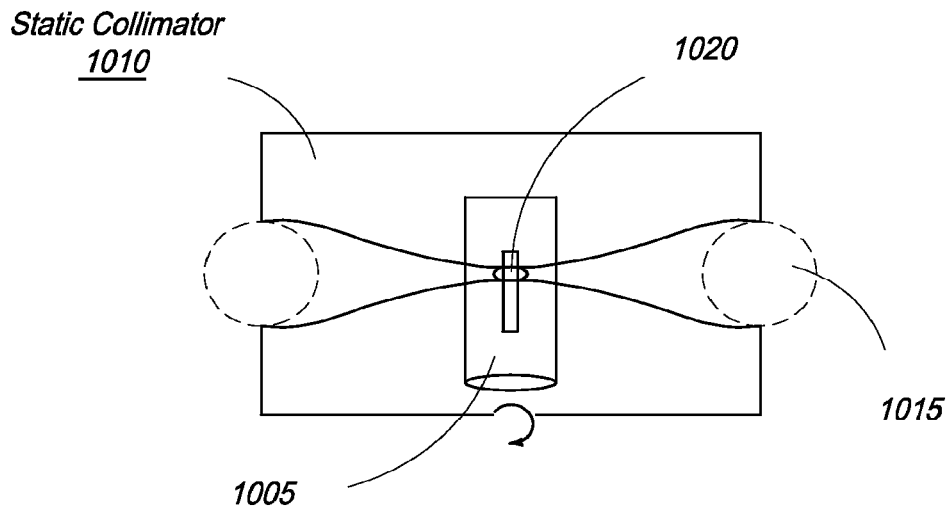

FIG. 10A

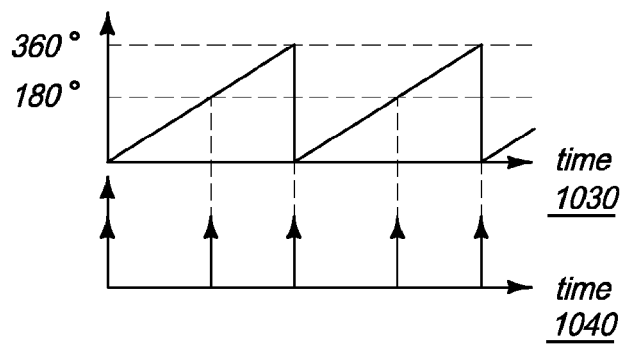

FIG. 10B

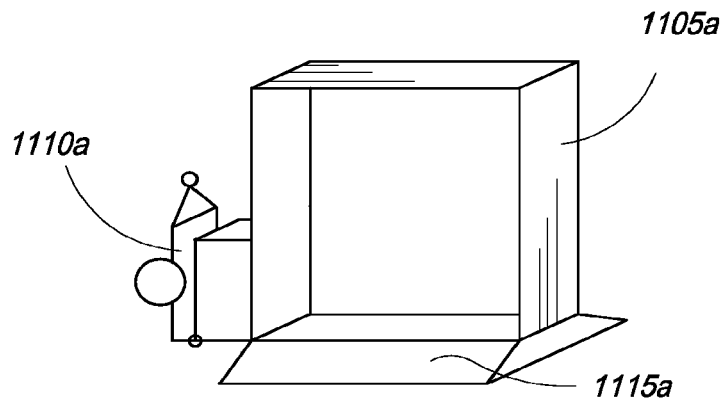

FIG. 11A

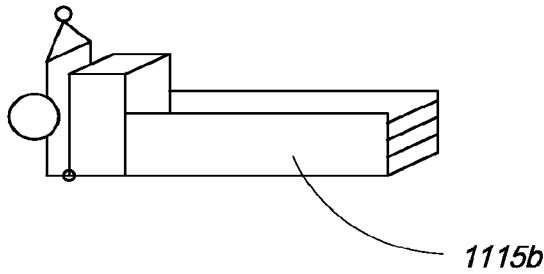

FIG. 11B

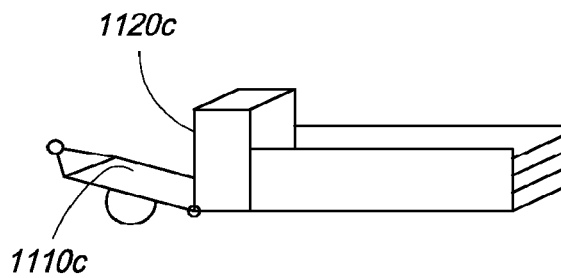

FIG. 11C

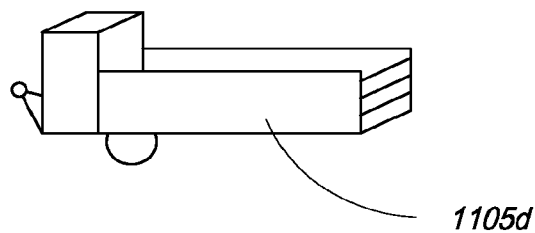

FIG. 11D

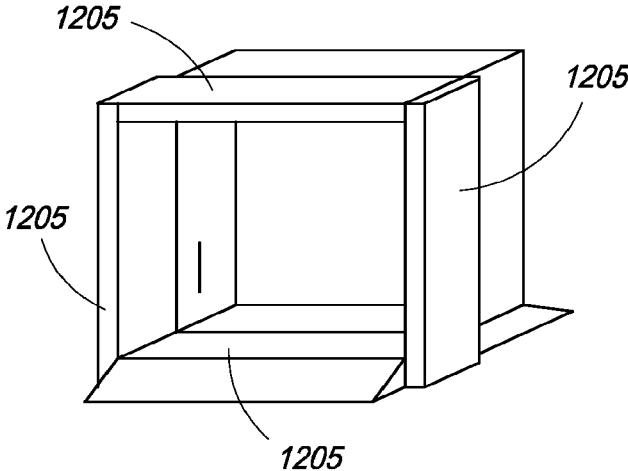

FIG. 12

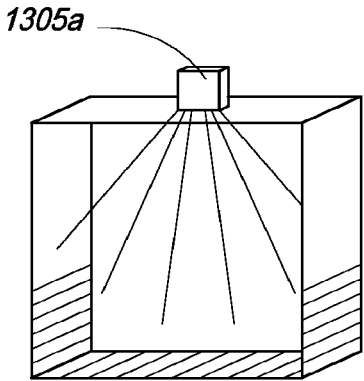

FIG. 13A

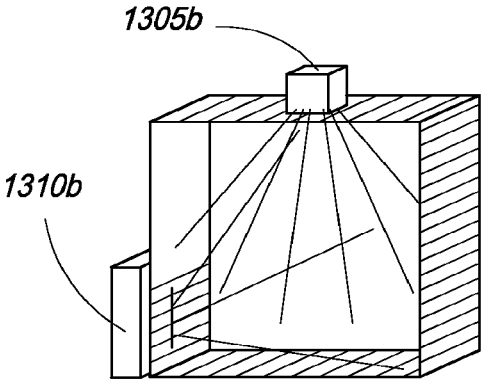

FIG. 13B

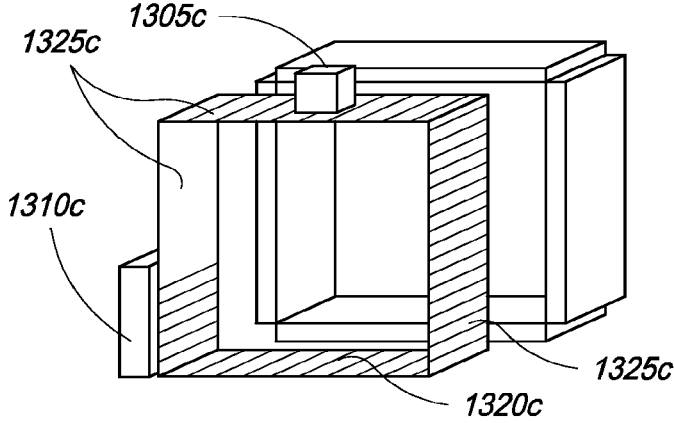

FIG. 13C

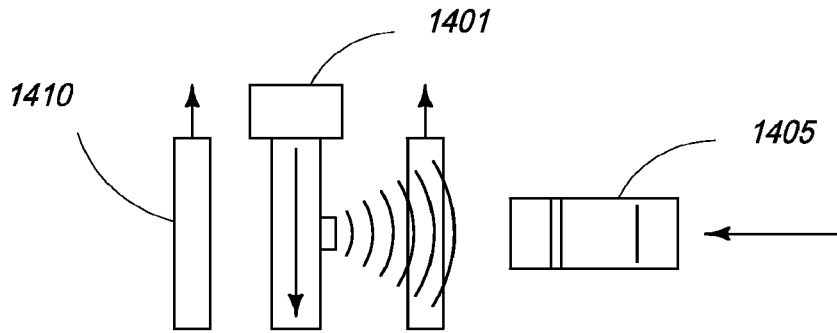

FIG. 14

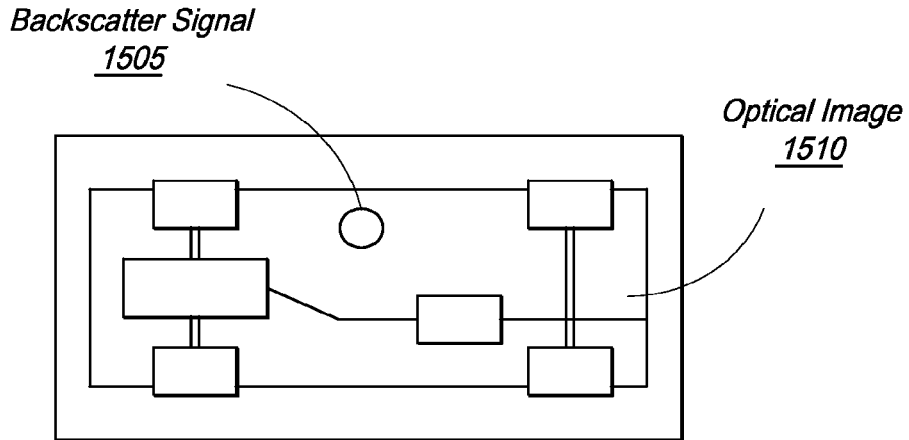

FIG. 15

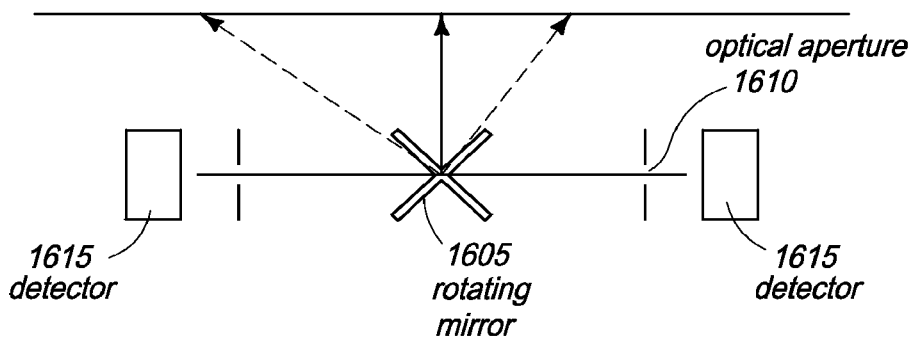

FIG. 16

**MOBILE IMAGING SYSTEM AND METHOD
FOR DETECTION OF CONTRABAND**

CROSS REFERENCE

This application relies on U.S. Patent Provisional No. 61/224,938 filed on Jul. 13, 2009 and is hereby incorporated by reference in its entirety.

The present invention is a continuation-in-part of U.S. patent application Ser. No. 12/396,568, entitled "Single Boom Cargo Scanning System", and filed on Mar. 3, 2009, which is a continuation-in-part of U.S. patent application Ser. No. 11/948,814, entitled, "Single Boom Cargo Scanning System", filed on Nov. 30, 2007, and now issued U.S. Pat. No. 7,517,149, which is a continuation of U.S. Pat. No. 7,322,745, entitled, "Single Boom Cargo Scanning System", filed on Aug. 9, 2004, which relies on, for priority, U.S. Provisional Patent Application No. 60/493,935, filed on Aug. 8, 2003 and is a continuation-in-part of U.S. patent application Ser. No. 10/201,543, entitled "Self-Contained Portable Inspection System and Method", filed on Jul. 23, 2002 and now U.S. Pat. No. 6,843,599. The '591 application further relies on U.S. Provisional Application No. 61/014,814, filed on Dec. 19, 2007, for priority.

The present invention is also a continuation-in-part of U.S. patent application Ser. No. 12/395,760, entitled "Single Boom Cargo Scanning System", and filed on Mar. 2, 2009, which is a continuation-in-part of U.S. patent application Ser. No. 12/051,910, entitled "Single Boom Cargo Scanning System", and filed on Mar. 20, 2008, now issued U.S. Pat. No. 7,519,148, which is a continuation of U.S. Pat. No. 7,369,463, of the same title, filed on Jan. 12, 2007, which is a continuation-in-part of U.S. Pat. No. 7,322,745.

The present invention is a continuation-in-part of U.S. patent application Ser. No. 12/339,591, entitled Rotatable Boom Cargo Scanning System, filed on Dec. 19, 2008, which is a continuation-in-part of U.S. patent application Ser. No. 11/948,814, described above and also a continuation-in-part of U.S. patent application Ser. No. 12/051,910, described above.

The present invention is also a continuation-in-part of U.S. patent application Ser. No. 12/753,976, entitled "Self-Contained Mobile Inspection System", and filed on Apr. 5, 2010, which is a continuation-in-part of Ser. No. 12/349,534, of the same title, and filed on Jan. 7, 2009 (and now issued U.S. Pat. No. 7,720,195) which is a continuation of U.S. patent application Ser. No. 10/939,986, entitled "Self-Contained Mobile Inspection System", and filed on Sep. 13, 2004, which is a continuation-in-part of Ser. No. 10/915,687 (issued as U.S. Pat. No. 7,322,745), which is a continuation-in-part of Ser. No. 10/201,543 (issued as U.S. Pat. No. 6,843,599) and further relies on U.S. Provisional Patent Application No. 60/502,498, filed on Sep. 12, 2003, for priority.

The present invention is also a continuation-in-part of U.S. patent application Ser. No. 12/263,160, entitled "Cargo Scanning System", and filed on Oct. 31, 2008, which further relies on U.S. Provisional Patent Application No. 60/984,786, filed on Nov. 2, 2007, for priority, and is a continuation-in-part of U.S. Pat. No. 7,322,745.

The present invention is also a continuation-in-part of U.S. patent application Ser. No. 12/675,471, entitled "Scanning Systems", and filed on Feb. 26, 2010, which is a National Stage Entry of PCT/GB08/02897.

The present invention is also a continuation-in-part of U.S. patent application Ser. No. 12/784,630, entitled "Compact Cargo Mobile Scanning System", and filed on May 21,

2010, which further relies on U.S. Provisional Patent Application No. 61/180,471, of the same title, and filed on May 22, 2009, for priority.

All of the above-listed patent applications are herein incorporated by reference in their entirety.

FIELD OF THE INVENTION

The present invention relates to X-ray scanning and detection systems for screening cars, buses, larger vehicles, and cargo containers for suspicious trade and illicit substances. More specifically, the present invention relates to a four-sided imaging system that provides high detection performance using a combination of transmission and backscatter imaging sensors.

BACKGROUND OF THE INVENTION

X-ray systems are used for medical, industrial and security inspection purposes because they can cost-effectively generate images of internal spaces not visible to the human eye. Materials exposed to X-ray radiation absorb differing amounts of X-ray radiation and, therefore, attenuate an X-ray beam to varying degrees, resulting in a transmitted or backscattered level of radiation that is characteristic of the material. The attenuated or backscattered radiation can be used to generate a useful depiction of the contents of the irradiated object. A typical single energy X-ray configuration used in security inspection equipment may have a fan-shaped or scanning X-ray beam that is transmitted through or backscattered by the object inspected. The absorption or backscattering of X-rays is measured by detectors after the beam has passed through the object and an image is produced of its contents and presented to an operator.

Trade fraud, smuggling and terrorism have increased the need for such non-intrusive inspection systems in applications ranging from curbside inspection of parked vehicles to scanning in congested or high-traffic ports because transportation systems, which efficiently provide for the movement of commodities across borders, also provide opportunities for the inclusion of contraband items such as weapons, explosives, illicit drugs and precious metals. The term port, while generally accepted as referring to a seaport, also applies to a land border crossing or any port of entry.

With an increase in global commerce, port authorities require additional sea berths and associated container storage space. Additional space requirements are typically met by the introduction of higher container stacks, an expansion of ports along the coastline or by moving inland. However, these scenarios are not typically feasible. Space is generally in substantial demand and short supply. Existing ports operate under a routine that is not easily modified without causing disruption to the entire infrastructure of the port. The introduction of new procedures or technologies often requires a substantial change in existing port operating procedures in order to contribute to the port's throughput, efficiency and operability.

With limited space and a need to expand, finding suitable space to accommodate additional inspection facilities along the normal process route remains difficult. Additionally, selected locations are not necessarily permanent enough for port operators to commit to the long term installation of inspection equipment. Moreover, systems incorporating high-energy X-ray sources, or linear accelerators (LINAC), require either a major investment in shielding material (generally in the form of concrete formations or buildings)

or the use of exclusion zones (dead space) around the building itself. In either case, the building footprint is significant depending upon the size of cargo containers to be inspected.

A mobile inspection system offers an appropriate solution to the need for flexible, enhanced inspection capabilities. Because the system is relocatable and investing in a permanent building in which to accommodate the equipment is obviated, site allocation becomes less of an issue and introducing such a system becomes less disruptive. Also, a mobile X-ray system provides operators, via higher throughput, with the ability to inspect a larger array of cargo, shipments, vehicles, and other containers.

Conventional relocatable inspection systems generally comprise at least two booms, wherein one boom will contain a plurality of detectors and the other boom will contain at least one X-ray source. The detectors and X-ray source work in unison to scan the cargo on the moving vehicle. In conventional single boom relocatable inspection systems, the X-ray source is located on a truck or flatbed and the detectors on a boom structure extending outward from the truck. These systems are characterized by moving-scan-engine systems wherein the source-detector system moves with respect to a stationary object to be inspected. Also, the detectors and the source of radiation are either mounted on a moveable bed, boom or a vehicle such that they are integrally bound with the vehicle. This limits the flexibility of dismantling the entire system for optimum portability and adjustable deployment to accommodate a wide array of different sized cargo, shipments, vehicles, and other containers. As a result these systems can be complicated to deploy and pose several disadvantages and constraints. Conventional systems are disadvantageous in that they suffer from a lack of rigidity, are difficult to implement, and/or have smaller fields of vision.

Accordingly, there is need for improved inspection methods and systems built into a fully self-contained, over-the-road-legal vehicle that can be brought to a site and rapidly deployed for inspection. The improved method and system can, therefore, service multiple inspection sites and set up surprise inspections to thwart contraband traffickers who typically divert smuggling operations from border crossings that have tough interdiction measures to softer crossings with lesser inspection capabilities. Moreover, there is an additional need for methods and systems that require minimal footprint to perform inspection and that use a sufficient range of radiation energy spectrum to encompass safe and effective scanning of light commercial vehicles as well as substantially loaded 20-foot or 40-foot ISO cargo containers. It is important that such scanning is performed without comprising the integrity of the cargo and should ideally be readily deployable in a variety of environments ranging from airports to ports of entry where a single-sided inspection mode needs to be used due to congested environments. Similar needs are addressed in U.S. Pat. No. 6,543,599, entitled "Self-Contained Portable Inspection System and Method", which is herein incorporated by reference in its entirety. In addition, there is a need for improved methods and systems that can provide comprehensive cargo scanning in portable and stationary settings.

Further, in the mobile cargo inspection systems known in the art, the boom structures are typically heavy, thereby causing the overall weight of the scanning system to be close to, or even over the allowable axle load limits. Further, the booms are bulky when stowed such that the vehicle is approximately 4 m high above road level. This makes a mobile scanning system not only difficult to manoeuvre but

also restricts its movement in different territories due to the applicable road restrictions on carriage weight. Therefore, there is also a need for a scanning system that can be stowed in a relatively compact area so that it can be easily transported on road, as well as by air. In addition, there is also a need for a scanning system which is light weight, and has a low height and center of gravity in a stowed position, thereby allowing for road transport even in challenging, steep and hilly areas.

Further, inspection typically occurs from only three or fewer directions. For example, a transmission X-ray system will be deployed in a side-shooter or top-shooter configuration while a backscatter system is generally only available in single-sided or three-sided configurations.

Therefore, what is also needed is a four-sided imaging system which provides high detection performance using a combination of transmission and backscatter imaging sensors.

SUMMARY OF THE INVENTION

In one embodiment, the present invention is a scanning system for the inspection of cargo, comprising: a portal defining an inspection area, said portal comprising a first vertical side, a second vertical side, a top horizontal side, and a horizontal base defined by a ramp adapted to be driven over by a vehicle, a first X-ray source disposed on at least one of the first vertical side, second vertical side or top horizontal side for generating an X-ray beam into the inspection area toward the vehicle, a first set of transmission detectors disposed within the portal for receiving the X-rays transmitted through the vehicle, a second X-ray source disposed within the ramp of said portal for generating an X-ray beam towards the underside of the vehicle, and a second set of detectors disposed within the ramp of said portal for receiving X-rays that are backscattered from the vehicle.

In one embodiment, the system is collapsible. In one embodiment, the ramp comprises a base platform hinged to a first angled surface and a second angled surface and wherein, when said system is collapsed, the first angled surface and second angled surface are rotated upward.

In one embodiment, the top horizontal side is connected to said first vertical side at a first end and to said second vertical side at a second end and wherein the first X-ray source is disposed at a point mid way between said first end and said second end.

In one embodiment, the first X-ray source is a high energy source having an energy ranging from 100 kVp to 2 MV. In another embodiment, the second X-ray source is a low energy source having an energy ranging from 60 kVp to 250 kVp.

In one embodiment, the system further comprises a controller, wherein said controller is adapted to activate the first X-ray source only when the second X-ray source is inactive.

In one embodiment, the system further comprises a primary rotating collimator placed adjacent to said first X-ray source, and a secondary static collimator placed adjacent to said rotating collimator and parallel to the inspection surface, wherein said secondary collimator is adapted to generate a first irradiation area in the center of the inspection area and a second irradiation area at a periphery of the inspection area and wherein said second irradiation area is larger than the first irradiation area.

In one embodiment, the system further comprises backscatter detectors in at least one of said first vertical side, said second vertical side, and said top horizontal side. In another

5

embodiment, the backscatter X-ray source is not disposed with said backscatter detectors in at least one of said first vertical side, said second vertical side, and said top horizontal side.

In another embodiment, the present invention is a method for inspecting a vehicle, comprising: providing a portal defining an inspection area, said portal comprising a first vertical side, a second vertical side, a top horizontal side, and a horizontal base defined by a ramp adapted to be driven over by a vehicle; signalling a vehicle to drive over the ramp; irradiating a vehicle with X-rays from a first source disposed on one side of the portal; detecting the X-rays transmitted through the vehicle, using transmission detectors disposed within the portal, to produce a first output signal representative of the vehicle and contents thereof; irradiating the underside of the vehicle with X-rays from a second source disposed within the ramp; detecting X-rays scattered back from the vehicle, using backscatter detectors disposed within the ramp, to produce a second output signal representative of the vehicle and contents thereof; and correlating said first output signal and said second output signal to produce a visual image of the vehicle and contents thereof. In one embodiment, the first X-ray source is operated when said second X-ray source is inactive.

In yet another embodiment, the present invention is a scanning system for inspecting a vehicle, comprising: a portal defining an inspection area, said portal comprising a first vertical side and a second vertical side spaced apart from each other and each having a top side; a third side connecting said two top sides; a ramp over adapted to be driven over by a vehicle; an X-ray source disposed on one side of the portal for generating an X-ray beam into the inspection area; a first set of detectors disposed within the portal for receiving X-rays transmitted through the vehicle; a second set of detectors disposed within the ramp and the first, second and third sides of said portal for receiving X-rays backscattered from the vehicle; and an image processor for receiving output signals from said first and second set of detectors and overlaying said output signals onto a visual image of the vehicle and contents thereof.

In one embodiment, the first set of detectors is disposed on at least two of the same sides of the portal as the second set of detectors. In one embodiment, the first set of detectors comprises a first detector and a second detector adapted to measure an energy component of X-rays transmitted through the vehicle in a range of 0 keV to 50 keV and 20 keV to 200 keV, respectively, and a third detector to measure an energy component of X-rays transmitted through the vehicle in a range of 100 keV to 2 MeV. In one embodiment, the three detectors are in a stacked configuration. In one embodiment, a difference between an output of the third detector and a sum of outputs of the first and second detectors is used to achieve material discrimination.

In one embodiment, the system further comprises a sensor to measure a speed of the vehicle as it passes through the portal. In one embodiment, the system further comprises a controller wherein said controller is in data communication with the sensor and receives the speed of vehicle and wherein said controller is adapted to modulate a pulse rate of the X-ray source to attain a substantially constant dose per unit length of the vehicle under inspection based on the speed.

BRIEF DESCRIPTION OF THE DRAWINGS

These and other features and advantages of the present invention will be appreciated, as they become better under-

6

stood by reference to the following detailed description when considered in connection with the accompanying drawings, wherein:

FIG. 1 is a schematic representation of the four-sided X-ray imaging system of the present invention;

FIG. 2 illustrates an orthogonal view of the four-sided X-ray imaging system of the present invention;

FIG. 3a is a schematic representation of one embodiment of a readily collapsible X-ray imaging system in a first configuration;

FIG. 3b illustrates an orthogonal view of one embodiment of a readily collapsible X-ray imaging system in a first configuration, as shown in FIG. 3a;

FIG. 3c is a schematic representation of one embodiment of a readily collapsible X-ray imaging system in a second configuration;

FIG. 3d illustrates an orthogonal view of one embodiment of a readily collapsible X-ray imaging system in a second configuration, as shown in FIG. 3c;

FIG. 3e is a schematic representation of one embodiment of a readily collapsible X-ray imaging system in a third configuration;

FIG. 3f illustrates an orthogonal view of one embodiment of a readily collapsible X-ray imaging system in a third configuration, as shown in FIG. 3e;

FIG. 4 is an illustration of one embodiment of a triple-stacked detector element;

FIG. 5 is an integrator circuit diagram of signal processing as signals from each detector element are passed to the integrator circuits;

FIG. 6a is a graphical representation of analyzed digital sensor values;

FIG. 6b is another graphical representation of analyzed digital sensor values;

FIG. 7 is an illustration of one embodiment of a sensor that is capable of collecting backscattered radiation information and generating a backscatter image of a region;

FIG. 8 is a representative cross-section of one embodiment of an X-ray source that may be used with the present invention;

FIG. 9 is an illustration of the X-ray beam as it comes into contact with the object under inspection and the subsequent backscatter;

FIG. 10a is an illustration of one embodiment of the present invention in which a pencil-like rotating collimator is replaced with a slot-like rotating collimator;

FIG. 10b is a graphical representation of the time at which a pulsed X-ray source can be fired to create a corresponding line of an X-ray transmission image with no interference from the backscatter detector;

FIG. 11a is an illustration of another embodiment of the present invention in which the scanning assembly may optionally be integrated with a transport trailer, in a first configuration;

FIG. 11b is an illustration of another embodiment of the present invention in which the scanning assembly may optionally be integrated with a transport trailer, in a second configuration;

FIG. 11c is an illustration of another embodiment of the present invention in which the scanning assembly may optionally be integrated with a transport trailer, in a third configuration;

FIG. 11d is an illustration of another embodiment of the present invention in which the scanning assembly may optionally be integrated with a transport trailer, in a fourth configuration;

FIG. 12 depicts another embodiment of the present invention in which a four-sided backscatter detector is mounted around the periphery of the scanning volume/tunnel;

FIG. 13a depicts another embodiment of the X-ray system of the present invention with an alternate transmission X-ray imaging geometry;

FIG. 13b depicts another embodiment of the X-ray system of the present invention with an alternate transmission X-ray imaging geometry;

FIG. 13c depicts another embodiment of the X-ray system of the present invention with an alternate transmission X-ray imaging geometry;

FIG. 14 is an illustration on another embodiment of the present invention where the system further includes vehicle detect sensors;

FIG. 15 is a composite image which overlays a backscatter signal with an optical image; and

FIG. 16 depicts an exemplary mechanism by which the optical image can be generated by taking an image signal from a mirror.

DETAILED DESCRIPTION

The present invention is directed towards a four-sided imaging system that provides high detection performance using a combination of transmission and backscatter imaging sensors. The present invention is directed towards multiple embodiments. Language used in this specification should not be interpreted as a general disavowal of any one specific embodiment or used to limit the claims beyond the meaning of the terms used therein. Reference will now be made in detail to specific embodiments of the invention. While the invention will be described in conjunction with specific embodiments, it is not intended to limit the invention to one embodiment.

FIG. 1 is a schematic representation of one embodiment of a four-sided X-ray imaging system 100. As shown in FIG. 1, vehicle 105 drives over a ramp 110 and underneath an archway 115, which defines an inspection portal. Specifically, the portal is defined by a first (left) side 106, a second (right) side 107, a top side 108 and a bottom platform 109, which is a portion of the ramp. In one embodiment, ramp 110 comprises a base, a first angled surface leading upward to a flat transition point defining the highest part of the ramp, which also functions as the bottom platform 109, and a second angled surface leading back down to the ground. The highest part of the ramp is typically between 50 and 150 mm in height. In one embodiment, archway 115 houses multiple X-ray transmission detectors 117 and at least one X-ray source 119, housed within an enclosure, shown as 220 in FIG. 2.

While FIG. 1 depicts the X-ray source 119 as being on the left side 106 of the portal, one of ordinary skill in the art would appreciate that it could be on the right side 107, with an appropriate reconfiguration of the detectors 117. In one embodiment, the first side 106 has a height 106a in a range of 2 meters to 5 meters and a width 106b in a range of 2 meters to 4 meters; the second side 107 has a height 107a in a range of 2 meters to 5 meters and a width 107b in a range of 2 meters to 4 meters; the top side 108 has a length 108a in a range of 2 meters to 5 meters and a width 108b in a range of 2 meters to 4 meters; and the bottom platform 109 has a length 109a in a range of 2 meters to 5 meters and a width 109b in a range of 2 meters to 4 meters, where the width depends upon the location of the main aperture. Further, bottom platform 109 has a height in a range of 0.2 meter to 0.4 meter, depending upon the width; in one embodiment, a

bottom platform 109 having a width of 2 meters has a height of 0.2 meter. Accordingly, the four sides, each having an interior face directed toward in the inspection region and an exterior face directed away from the inspection region, define an inspection portal having an inspection area of a minimum of 2 m² to a maximum of 20 m².

Preferably, the enclosure housing the X-ray is physically attached to the exterior face of the first side 106 and is approximately 1 meter tall. The position of the enclosure depends upon the size of the inspection portal. In one embodiment, the enclosure occupies 20% to 50% of the total height of the first side 106. Thus, in one embodiment, if first side 106 is five meters, then the enclosure occupies 20% of the total height. In another embodiment, if first side 106 is 2 meters, the enclosure occupies 50% of the height.

In one embodiment, a slit or opening 121 is provided on first side 106, through which X-rays are emitted. Slit or opening 121 extends substantially up first side 106 to approximately 100% of the height. In one embodiment, slit or opening 121 is covered with a thin coating that is easily transparent to an X-ray. In one embodiment, the thin coating is comprises of a material such as aluminium or plastic and further provides an environmental shield.

In one embodiment, the enclosure and X-ray unit further comprise a first collimator close to the source of X-rays (not shown) and a second collimator close to the exit (not shown), described in greater detail below.

Where the X-ray source enclosure is so positioned, detectors 117 are positioned on the interior face of the second side 107 and the interior face of top side 108 and occupy the full height of second side 107 and the full length of top side 108, proximate to second side 107.

In another embodiment, the enclosure housing the X-ray is physically attached to the exterior face of the second side 107 and is approximately 1 meter tall. The position of the enclosure depends upon the size of the inspection portal. In one embodiment, the enclosure occupies 20% to 50% of the total height of the first side 107. Thus, in one embodiment, if first side 107 is five meters, then the enclosure occupies 20% of the total height. In another embodiment, if first side 107 is 2 meters, the enclosure occupies 50% of the height. As described above with respect to first side 106, if the enclosure housing the X-ray is on second side 107, a slit or opening (not shown) is similarly provided on second side 107. The detectors are also similarly positioned on the interior faces of top side 108 and first side 106 when the enclosure is on second side 107.

In one embodiment, with a dual-view system, an enclosure housing an X-ray source can be provided on both the first side 106 and second side 107.

FIG. 2 illustrates an orthogonal view of the system 200, showing both inlet ramp 210a and exit ramp 210b, as well as the X-ray source enclosure 220, containing X-ray source 219.

A transmission system in a "side-shooter" configuration, where the source enclosure is positioned on the first side or second side and emit X-rays toward one side of the vehicle, provides clear inspection of the doors, seats, engine compartment, luggage compartment and roof of the vehicle under inspection. However, such an image provides poor inspection of the floor plan of the vehicle. A "down-shooter" configuration, where the source enclosure is positioned the bottom portion of the first side or second side and emit X-rays from this bottom, lower position in an upward direction, provides a limited inspection capability for the roof of the vehicle since the X-ray signal for this region is

superimposed over the complex and more attenuating X-ray signal of the floor (and passengers), thus resulting in an image of marginal value.

In order to provide good penetration of the denser, more highly attenuating objects within the vehicle, such as the engine and luggage compartments, it is advantageous to use a high energy X-ray source, even if tuned to a low output intensity. A suitable high voltage source has an energy ranging from 100 kVp to 2 MV. In one embodiment, at lower energies, a standard X-ray tube source is employed. In another embodiment, at higher energies, a pulse linear accelerator source is employed. In one embodiment of the present invention, standard operating energies are 200 kVp for the lower energy and 1 MV for the higher energy.

Referring back to FIG. 1, in order to provide a high level of inspection capability, ramp 110, over which the vehicle drives is equipped with, and contains therein, a backscatter X-ray unit which comprises a low energy X-ray source, typically having an energy ranging from 60 kVp to 250 kVp, and a plurality of detectors. It should be appreciated that the backscatter unit can be integrated into any floor structure which is movable and deployable to different locations and over which a car can drive. The backscatter signal from the floor of the vehicle is influenced strongly by regions of low atomic number material. Most regions of the vehicle floor are fabricated from high atomic number structural materials such as steel and therefore provide a small backscatter signal. The floor of a car is typically fabricated from relatively thin stamped steel, which typically has a thickness in the range of 1-2 mm. Typically, an X-ray beam can penetrate through this floor and into the objects just above. If low atomic number materials are positioned just above the floor, then these will be visible to X-ray backscatter detectors while they would be invisible to standard visual inspection.

In operating a four-sided imaging system which combines X-ray backscatter with X-ray transmission imaging, it is highly advantageous to use a pulsed accelerator based X-ray source for transmission imaging with a continuous output X-ray source for backscatter imaging since the transmission beam X-ray pulse may be timed to coincide with a period in time when the backscatter system is inactive, thus eliminating any cross-talk between the two X-ray systems and facilitating simultaneous four-sided X-ray inspection. It should also be appreciated that the transmission detectors and backscatter detectors are in data communication with a memory and processor which, in conjunction with a controller, generate one or more transmission and/or backscatter images.

Because it is highly advantageous to be able to rapidly and non-invasively deploy an X-ray system for security screening at a site in order to provide an element of surprise in the screening activity, in one embodiment, the present invention is a rapidly collapsible X-ray system that can be loaded onto a truck for transport between sites.

FIGS. 3a, 3b, 3c, 3d, 3e, and 3f depict one embodiment of a rapidly collapsible X-ray imaging system in several configurations. FIG. 3a is a schematic representation of one embodiment of a readily collapsible X-ray imaging system in a first configuration, wherein the system is in a fully deployed position. Rapidly collapsible X-ray imaging system 300 comprises horizontal X-ray sensor section 305, a vertical boom section 310, a drive-over backscatter section 315 and a vertical boom support and collimator section 320 through which the transmission beam propagates from source 319. Further, X-ray imaging system 300 comprises ramp 325 (inlet and outlet) which allows a vehicle to drive

over the X-ray backscatter unit seamlessly. FIG. 3b illustrates an orthogonal view of one embodiment of a readily collapsible X-ray imaging system as shown in FIG. 3a. FIG. 3b illustrates source 319, vertical support and collimator section 320, horizontal X-ray sensor section 305, and ramp 325.

The rapidly deployable system of the present invention can be made ready for operation in a period of only a few minutes from arrival at the inspection site. In one embodiment, in order to stow the system ready for transportation, and referring back to FIG. 3a, a set of hydraulic rams or other suitable mechanisms are used to collapse vertical boom sections 310 and 320 inward using hinges 321 and 322, respectively. Hinges 321 and 322 are positioned, in one embodiment, mid-way up the height of vertical boom sections 310 and 320, respectively. When vertical boom sections 310 and 320 are collapsed inward using hinges 321 and 322, horizontal boom section 305 is "lowered" such that it rests on top of collapsed vertical boom sections 310, 320.

FIG. 3c is a schematic representation of one embodiment of a readily collapsible X-ray imaging system in a second configuration, wherein vertical boom sections 310 and 320 are folded inwards and collapsed at hinges 321, 322. FIG. 3d illustrates an orthogonal view of one embodiment of a readily collapsible X-ray imaging system in a second configuration, as shown in FIG. 3c, further showing ramp 325 and source 319.

FIG. 3e is a schematic representation of one embodiment of a readily collapsible X-ray imaging system in a third configuration, wherein ramp sections 325 are folded upward using hydraulic rams or other suitable mechanisms. FIG. 3f illustrates an orthogonal view of one embodiment of a readily collapsible X-ray imaging system in a third configuration, as shown in FIG. 3e, illustrating ramp 325 which has been folded upwards at both the inlet and outlet. At this point, the system is ready for transport. It should be appreciated that the angled ramp outlet and inlet are hinged to the base platform and capable of moving up such that the tip 327 is directed upward, for achieving system mobility, and moving downward to form the completed ramp. The base platform preferably houses the above-described backscatter system.

In order to deploy the system, the X-ray imaging assembly is placed on site and powered on. Electrical power may be derived from a local mains electricity supply or from an integrated diesel generator. Hydraulic rams or other suitable mechanisms are then used to fold down the two portions (inlet and outlet) of the ramp 325. In one embodiment, the inlet and outlet portions of ramp 325 are folded simultaneously. Once the ramps 325 are down, a second set of hydraulic rams or other suitable mechanisms are used to open vertical boom sections 310 and 320. At this point, the system is ready for use.

In one embodiment, the X-ray imaging system of the present invention is capable of providing an image inspector with information relating to the types of material that are present in the object under inspection. In a large aperture inspection system of this type, a high energy X-ray beam is needed in order to penetrate through the object under inspection. This X-ray beam contains a broad spectrum of X-ray energies ranging from very low energies (typically less than 10 keV) up to the highest energy as determined by the tube or linear accelerator operating voltage (typically in the range of 100 keV to 2 MeV). Due to the unique composition of each material in the object under inspection, the materials each demonstrate specific attenuation of the

X-ray beam, wherein this attenuation also comprises an energy dependent component.

Conventionally, a low energy (typically less than 450 kVp) X-ray beam can yield material discrimination information when a thin front detector measures the low energy component of the beam and a thicker rear detector measures the higher energy components of the beam. Here, the two detectors analyze different materials in the object under inspection due to differential photoelectric absorption of the primary X-ray beam. In addition, in the case of a high energy beam (typically in the range 1 MV and above), the fraction of Compton scatter increases markedly. Two relatively thick detectors can be used to discriminate between materials where a first detector is used to absorb the majority of the signal below approximately 200 keV where photoelectric effect dominates while a second detector measures Compton-attenuated signal only.

FIG. 4 is a depiction of a triple-stacked detector. As shown in FIG. 4, incident X-ray beam 401 passes through two low energy detectors, LE₁ 405 and LE₂ 410, prior to passing through a high energy detector HE 415. Each detector may be formed from a range of X-ray detection materials such as a scintillator (which converts X-ray energy to optical radiation), a semiconductor (which converts X-ray energy to conduction band electrons) or a gas ionization detector (which converts X-ray energy to electron-ion pairs). In one embodiment, the detector configuration described with respect to FIG. 4 is employed with a 1 to 2 MeV system, where the beam energy is above 450 kVp. In one embodiment, first detector LE₁ 405 is capable of measuring an energy component of X-rays transmitted through the object in the range of 0 to 50 keV. In one embodiment, second detector LE₂ 410 is capable of measuring an energy component of X-rays transmitted through the object in the range of 20 to 200 keV. In one embodiment, third detector HE 415, is capable of measuring an energy component of X-rays transmitted through the object in the range of 100 keV to 2 MeV.

In each case, signals from each detector element are passed to integrator circuits, as shown in FIG. 5. In this embodiment, but not limited to such embodiment, a scintillation detector is employed in which an electrical signal generated in a photodiode is converted to a digital value which is directly proportional to the detected X-ray intensity. Independent scintillator/photodiode/integrator circuits are used for each of the three detector elements 405, 410, and 415, shown in FIG. 4.

Referring back to FIG. 5, in operation, integrator 500 is set with switches 505, 510, and 515 in an open position. Just prior to X-ray exposure, switch 505 is closed and integration starts. At the end of the exposure, switch 505 is opened and the stored charge is held on the capacitor. When the analog to digital converter (ADC) is available, switch 515 is closed, and the stored signal is converted to a digital value. At the end of conversion, switch 515 is opened again and switch 510 is closed. This resets the integrator 500 so that it is ready for the next acquisition cycle.

The obtained digital sensor values may then be analyzed, using the above described processor, as shown in FIGS. 6a and 6b. In FIG. 6a, the difference 605 between the two low energy sensors LE₁ and LE₂, is analyzed as a function of transmitted X-ray beam intensity 610. At both significantly low and significantly high attenuation regions, where there is either no information or where the object is thick and there is no transmission, respectively, the difference between the two sensors is small, but at intermediate intensities, the difference increases to yield material-specific dependence.

Two or more thresholds as a function of intensity can be derived to allow materials to be segmented, for example, into organic (Low-Z) and inorganic (High-Z) types, 615 and 620, respectively. Since this method relies on differential absorption of X-rays through the photoelectric effect, the technique does not provide a significant discrimination result at attenuation equivalent to a steel thickness of more than about 20 mm for an energy of about 180 keV or 40 mm for an energy of about 1 MeV.

As shown in FIG. 6b, using the processor to determine the ratio of Compton to photoelectric signals provides materials discrimination over a wider range of object attenuations and is suited to operation at larger material thicknesses. Thus in FIG. 6b, the difference 635 between the high energy sensor HE and the sum of the two low energy sensors LE₁ and LE₂ [i.e., HE-(LE₁+LE₂)] is analyzed as a function of transmitted X-ray beam intensity 640. Combining the two effects provides a significant improvement over using just two low energy sensors (LE₁ and LE₂) or a single low energy (LE₁ or LE₂) and a single high energy (HE) sensor.

Using the separately obtained X-ray backscattering signals, an alternate materials analysis can be performed. Here, the Compton interaction of an X-ray with an electron results in incoherent scattering in which the scattered X-ray has less energy than the incident X-ray. The ability of a material to scatter is dominated by its atomic number (which is roughly proportional to density for solid materials)—the higher the density or atomic number the better it is at scattering. However, dense materials are also very good at absorbing X-rays compared to low density materials. For this reason, low density materials tend to result in a stronger backscattering signal than high density materials. Such a backscatter signal can be used advantageously in a security inspection process.

It should be noted that a signal from an X-ray source falls off as the inverse square of the distance from the source, and thus becomes weaker the farther it is away from the object, with the same effect being true of the scattered radiation from the object. Further, the low energy backscattered signal is strongly absorbed by high density materials such as steel which means that this is a good technique for analysis of the steel floor pan in a car or similar small vehicle where one is interested in locating regions of low density material.

FIG. 7 is an illustration of one embodiment of a sensor that is capable of collecting backscattered radiation information and generating a backscatter image of a region. X-ray source 705 generates a thin pencil beam of radiation which, from within the base platform, sweeps rapidly from left to right over the two detector regions 710. The X-ray beam sweeps across the field of view of the object to be inspected typically in a time period of much less than a second and generally ranging from 5 ms to 100 ms. As the beam sweeps across the object under inspection the X-ray backscatter detectors 710 receive scattered signal from the adjacent interaction point of the primary X-ray beam with the object under inspection. The strength of the backscattered signal is dependent on the density at that region of the object. By temporal synchronisation readout of the detector element with the position of the primary beam location, a one-dimensional backscatter image can be obtained. Knowing the speed at which the vehicle moves past the sensor allows a two-dimensional image to be recreated from the set of one-dimensional image sections.

In one embodiment, the detectors are advantageously formed using a large area scintillation detector where the X-ray generated light is reflected into a large area photosensor such as a photomultiplier tube. An alternative

embodiment may comprise a gas ionization chamber with a drift field to speed up collection of ion and electron signal currents.

FIG. 8 is a representative cross-section of an X-ray source that may be used with the present invention. Radiation source **800**, with an extended anode **805**, is shown whereby anode **805** operates at ground potential with a cathode **810** at a negative high voltage. It will be apparent to one skilled in the art that alternative configurations with a grounded cathode and differential systems with a cathode at negative potential and anode at positive potential are also possible. The X-ray source is shielded by suitable materials, such as tungsten and lead, to prevent unwanted radiation from the X-ray tube from reaching the object under inspection.

An electric motor **815** and a gearbox **820** drive a collimator **825** which comprises a solid block of tungsten or a combined tungsten/lead/steel assembly forming one or more predetermined voids, spaces, or holes **830** which allow radiation to be emitted in a pencil-beam fashion in a direction perpendicular to the axis of rotation of the collimator **825**. Two such collimator holes **830** are shown diametrically opposed in FIG. 8. A high voltage connection **840** provides a point for electrical connection to the X-ray tube such that the high voltage power supply can be mounted remotely away from the X-ray inspection area.

While in operation, the axis of rotation of the collimator is in the direction of motion of the object under inspection such that the primary X-ray beam sweeps in a direction perpendicular to the motion of the object under inspection. As shown in FIG. 9, the X-ray beam **905** emerges from the source assembly **906** in a first direction and, at the point of intersection **907** of the primary beam **905** with the object to be inspected **910**, generates backscattered radiation **912**, which interacts with the adjacent X-ray detector **915**.

As described above, the intensity of the primary beam averaged over an area is dependent upon the distance of that measurement point from the source origin. For this reason, the signal received at the periphery of the scanning zone will be less intense than that received nearer to the center of the inspection zone for an identical scattering surface. To address this issue, as shown in FIG. **10a**, in one embodiment of the present invention, the pencil-like rotating collimator section is replaced with a slot-like rotating collimator section **1005**. A second collimation aperture **1010** is then placed adjacent to the rotating collimator and parallel to the inspection surface. The secondary collimator **1010** is narrow at the center of the inspection area **1015** (directly above the rotating slot collimator **1005**) and widens out at distance from the rotating slot collimator. This provides a small irradiation area **1020** in the centre of the inspection region where the primary beam intensity is high and a larger irradiation at the periphery of the inspection region where the primary beam intensity is lower. This preserves the dynamic range of the signal and makes it easier to both collect the data with good signal to noise ratio and to reconstruct the individual scan line object density.

In order to minimize cross talk between the backscatter imaging component and the transmission X-ray imaging system, it is advantageous to synchronize the operation of the two systems. For a rotating backscatter collimator with two apertures, each located substantially opposite to the other (i.e. one rotated at 180 degrees from the other) there are moments in time where neither collimator is emitting a beam onto the object. This occurs with the collimator at both 0 degrees and 180 degrees relative to the scanning plane.

Accordingly, As shown in FIG. **10b**, it is preferred to activate a pulsed X-ray source at time T_{1-N} **1030** to generate

a corresponding line of the transmission X-ray image when the collimator is not emitting a backscatter beam onto the object, shown as times T_{1-N} **1040**, thereby avoiding interference with the backscatter detector. In one embodiment, for an X-ray source pulsing at 100 Hz, the backscatter imaging collimator needs to operate at 50 revolutions per second or 300 RPM. By placing a phase lock loop or equivalent feedback circuit between the collimator motor controller and the X-ray transmission source controller, it is possible to adjust the frequency of the collimator and X-ray source to take into account variation in speed of the object under inspection as it passes through the X-ray imaging system.

As shown in FIGS. **11a**, **11b**, **11c**, and **11d**, in another embodiment of the present invention, the mechanical scanning assembly may optionally be integrated with a trailer to permit towing of the equipment behind a vehicle. FIG. **11a** shows system **1105a** in a first configuration, deployed and ready for use where the transport trailer **1110a** is folded up at the side of the inspection system and vehicle ramps **1115a** are in an open and ready to be drive-over position. When it is time to stow the equipment, the detector arrays are folded down and the vehicle ramps **1115b** are folded up, as shown in FIG. **11b** such that the system is in a second configuration. As shown in FIG. **11c**, in a third configuration, the trailer **1110c** is lowered, lifting up one end of the imaging equipment **1120c**. As shown in FIG. **11d**, a winch or other mechanism is then used to pull the X-ray system **1105d** onto the trailer ready for transport, in a fourth configuration. To deploy the system, the above described process is implemented in reverse. Advantageously, the vehicle which is used to tow the trailer is provided with image inspection computers, which one or more operators can use to analyze images and so divert and stop vehicles for further search as required and which comprises the aforementioned memory and processors used to process incoming backscatter and transmission data signals.

FIG. **12** depicts another embodiment of the present invention in which a four-sided backscatter detector **1205** is mounted around the periphery of the scanning tunnel. Each panel of the detector is similar to the sensor described with reference to FIGS. **7**, **8**, **9**, and **10a**, but now a four-sided backscatter image may also be generated. Advantageously, the backscatter detectors are mounted to the same frame as the transmission X-ray system such that simultaneous transmission and backscatter image data can be acquired. This allows overlay of backscatter and transmission X-ray images by suitable image manipulation. In this embodiment, backscatter detectors, and not a backscatter X-ray source, are integrated into one or more of the first side **106**, second side **107**, and top side **108**. Alternatively, backscatter detectors, and not a backscatter X-ray source, may be integrated into all three of the first side **106**, second side **107**, and top side **108**. Alternatively, backscatter detectors with a backscatter X-ray source may be integrated into one or more of the first side **106**, second side **107**, and top side **108**.

FIGS. **13a**, **13b**, and **13c** depict other embodiments of the X-ray system of the present invention with alternate transmission X-ray imaging geometries. FIG. **13a** shows the X-ray source **1305a** in a "down-shooter" configuration, while FIG. **13b** shows a combination or dual-view system that includes both "down-shooter" **1305b** and "side-shooter" **1310b**. FIG. **13c** shows a dual-view system, with both down-shooter **1305c** and side-shooter **1310c**, further comprising a four-sided backscatter system, with a backscatter source and backscatter detectors integrated into the base of the system **1320c** and backscatter detectors, together with

15

transmission detectors, integrated into each of the remaining three sides **1325c**. It should be evident to those of ordinary skill in the art that other configurations can be derived based on this disclosure.

FIG. **14** is an illustration of one embodiment of the present invention where the system further comprises at least one, and preferably a combination of two, vehicle presence detection sensors **1405** and **1410**, to the right and left, respectively, of the main gantry **1401**. Sensor **1405** is used to turn the X-ray beam on when the vehicle approaches. This is the right-most sensor when the vehicle approaches from the right as shown in the diagram. Sensor **1410** (the left most sensor in the diagram) is used to turn the X-ray beam off once the vehicle has passed through the imaging plane. In one embodiment, an additional sensor may be used to measure the speed of the vehicle as it passes through the sensor. Vehicle speed may be used to modulate the speed of collimator rotation and source pulse rate to ensure that good image quality is maintained independent of vehicle speed. This also allows a constant dose per unit length of the vehicle under inspection to be delivered which helps to ensure a known and safe dose to the driver and other occupants of the vehicle during X-ray screening.

FIG. **15** shows a composite image which overlays the X-ray backscatter signal **1505** from the underside of the vehicle under inspection to be correlated with an optical image **1510** of the same vehicle that is acquired using a suitable optical system at the same time the X-ray image is acquired.

FIG. **16** shows an exemplary mechanism by which the optical image can be generated by taking an image signal from a mirror **1605** which rotates with the X-ray collimator through one or more optical filters **1610** to one or more photo detectors **1615**. This configuration ensures the optical image is captured at a known time relative to the generation of a transmission image.

While there has been illustrated and described what is at present considered to be a preferred embodiment of the present invention, it will be understood by those skilled in the art that various changes and modifications may be made, and equivalents may be substituted for elements thereof without departing from the true scope of the invention. In addition, many modifications may be made to adapt a particular situation or material to the teachings of the invention without departing from the central scope thereof. Therefore, it is intended that this invention not be limited to the particular embodiment disclosed as the best mode contemplated for carrying out the invention, but that the invention will include all embodiments falling within the scope of the appended claims.

We claim:

1. A mobile scanning system for inspecting cargo carried by a vehicle, the mobile scanning system having a first configuration and a second configuration, comprising:

a portal defining an inspection area, said portal comprising a first side, a second side, a top side, and a base, wherein the base further comprises a first ramp and a second ramp;

a first X-ray source disposed on at least one of the first side, second side or top side for generating an X-ray beam into the inspection area toward the vehicle; and
a first set of transmission detectors disposed within the portal for receiving the X-rays transmitted through the vehicle,

wherein, in the first configuration,

(i) the first ramp and second ramp are inclined and positioned substantially horizontally,

16

(ii) the first side is positioned vertically and on a different side of the mobile scanning system relative to the first ramp and second ramp,

(iii) the second side is positioned vertically and on a different side of the mobile scanning system relative to the first ramp and second ramp, and

(iv) the top side is positioned horizontally atop the first side and second side, and

wherein, in the second configuration,

(i) the first ramp and second ramp are folded upward, such that the first and second ramps are positioned substantially vertically,

(ii) the first side is folded downward such that it is positioned horizontally,

(iii) the second side is folded downward such that it is positioned horizontally, and

(iii) the top side is positioned horizontally adjacent the first side and second side.

2. The mobile scanning system of claim 1 further comprising a second X-ray source disposed within the base of said portal for generating an X-ray beam towards an underside of the vehicle.

3. The mobile scanning system of claim 2, wherein said second X-ray source is a low energy source having an energy ranging from 60 kVp to 250 kVp.

4. A method of scanning cargo using the mobile scanning system of claim 2 comprising, when the mobile scanning system is operated, activating the first X-ray source only when the second X-ray source is inactive.

5. The mobile scanning system of claim 1 further comprising a second set of detectors disposed within the base of said portal for receiving X-rays that are backscattered from the vehicle.

6. The mobile scanning system of claim 1 further comprising a trailer attached to at least one of the first side or second side.

7. The mobile scanning system of claim 6 wherein, in the first configuration, the trailer is folded up toward at least one of the first side and second side and wherein, in the second configuration, the trailer is lowered such that at least one of the first side and second side is lifted upward.

8. The mobile scanning system of claim 1 wherein, in the second configuration, the first ramp and second ramp are folded upward, such that the first side, second side, and top side are positioned between the first ramp and the second ramp.

9. The mobile scanning system of claim 1, wherein said first X-ray source is a high energy source having an energy ranging from 100 kVp to 2 MV.

10. A mobile scanning system for inspecting cargo, the mobile scanning system having a first configuration and a second configuration, comprising:

a portal defining an inspection area, said portal comprising a first side, a second side, a top side, and a ramp, wherein the ramp further comprises a base platform hinged to a first angled surface and a second angled surface;

a first X-ray source disposed on at least one of the first side, second side or top side for generating an X-ray beam into the inspection area; and

a first set of detectors disposed within the portal for receiving the X-rays transmitted through the cargo,

wherein, in the first configuration,

(i) the first angled surface and second angled surface are positioned substantially horizontally,

17

(ii) the first side is positioned vertically and on a different side of the mobile scanning system relative to the first angled surface and second angled surface,

(iii) the second side is positioned vertically and on a different side of the mobile scanning system relative to the first angled surface and second angled surface, and

(iv) the top side is positioned horizontally atop the first side and second side, and

wherein, in the second configuration,

(i) the first angled surface and second angled surface are rotated upward, such that the first and second angled surfaces are positioned substantially vertically,

(ii) the first side is folded such that it is positioned horizontally,

(iii) the second side is folded such that it is positioned horizontally, and

(iv) the top side is positioned adjacent the first side and second side.

11. The mobile scanning system of claim 10 further comprising a second X-ray source disposed within the ramp of said portal for generating an X-ray beam towards an underside of the cargo.

12. The mobile scanning system of claim 10 further comprising a second set of detectors disposed within the base of said portal for receiving X-rays that are backscattered from the cargo.

13. The mobile scanning system of claim 10 further comprising a trailer attached to at least one of the first side or second side.

14. The mobile scanning system of claim 13 wherein, in the first configuration, the trailer is folded up toward at least one of the first side or second side and wherein, in the second configuration, the trailer is lowered such that at least one of the first side or second side is lifted upward.

18

15. The mobile scanning system of claim 10 wherein, in the second configuration, the first angled surface and second angled surface are folded upward, such that the first side, second side, and top side are positioned between the first ramp and the second ramp.

16. The mobile scanning system of claim 10 further comprising a primary rotating collimator placed adjacent to said first X-ray source, and a secondary static collimator placed adjacent to said rotating collimator and parallel to the inspection area, wherein said secondary collimator has a first structure that generates a first irradiation area in the center of the inspection area and a second structure that generates a second irradiation area at a periphery of the inspection area and wherein said second irradiation area is larger than the first irradiation area.

17. The mobile scanning system of claim 10 further comprising a backscatter detector in at least one of said first side, said second side, and said top side.

18. The mobile scanning system of claim 10, wherein said first set of detectors comprises a first detector and a second detector configured to detect an energy component of X-rays transmitted through the cargo in a range of 0 keV to 50 keV and 20 keV to 200 keV, respectively, and a third detector configured to detect an energy component of X-rays transmitted through the cargo in a range of 100 keV to 2 MeV.

19. The mobile scanning system of claim 18, wherein said three detectors are in a stacked configuration.

20. The mobile scanning system of claim 18, wherein a difference between an output of the third detector and a sum of outputs of the first and second detectors is used to achieve material discrimination.

* * * * *