

C. R. HALL.
CAR FENDER.

No. 523,427.

Patented July 24, 1894.

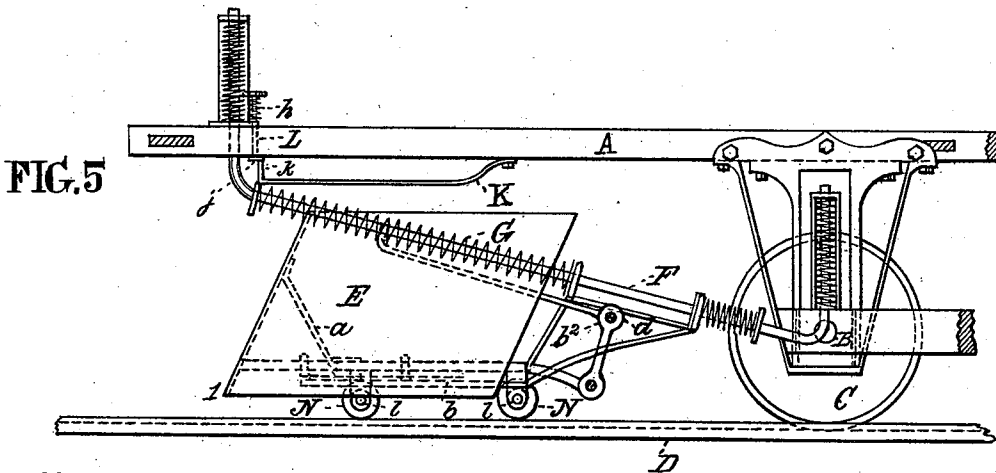
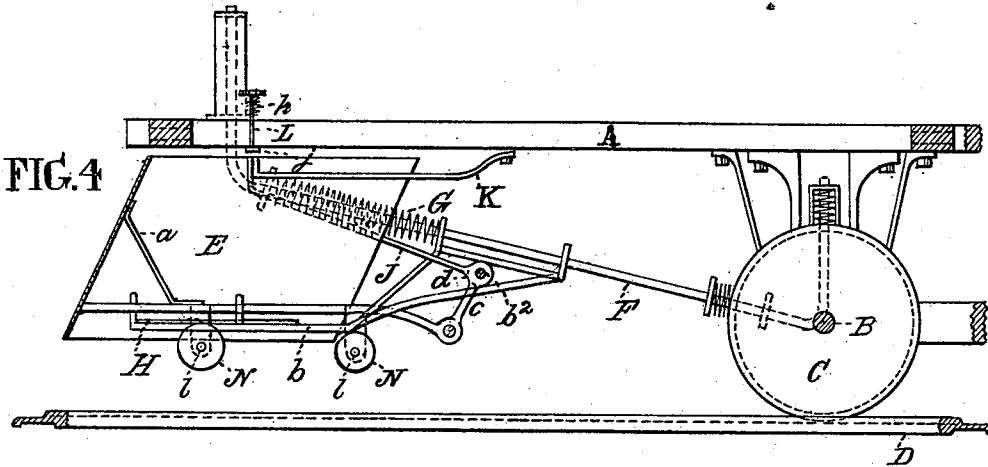
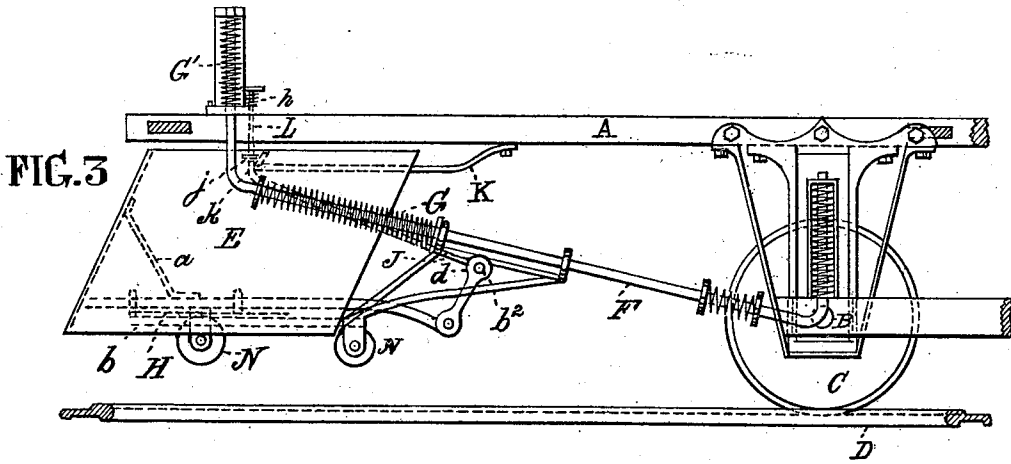

WITNESSES.

L. & W. Bewley.
M. Barnes.

INVENTOR.

Charles R. Hall.
per Thomas J. Bewley, atty.

UNITED STATES PATENT OFFICE.

CHARLES R. HALL, OF PHILADELPHIA, PENNSYLVANIA, ASSIGNOR OF ONE-THIRD TO CHARLES E. JONES, OF SAME PLACE.

CAR-FENDER.

SPECIFICATION forming part of Letters Patent No. 523,427, dated July 24, 1894.

Application filed May 24, 1894. Serial No. 512,268. (No model.)

To all whom it may concern:

Be it known that I, CHARLES R. HALL, a citizen of the United States, residing at Philadelphia, in the county of Philadelphia and State of Pennsylvania, have invented certain new and useful Improvements in Mechanism for Operating Fenders for Street-Railway Cars, of which the following is a specification.

The invention relates to an improvement in automatic fenders for street railway cars, for the removal of bodies, or obstructing masses from the surface of the bed of the rail-road, and thereby avoiding the passage of the car over the same. And consists of a fender constructed of sheet metal, placed at the front, or forward end of the car, below the under surface of the platform, and in front of the wheels, it being held in an advanced and elevated position, by means of suitable mechanism controlled by the operator, and capable of being lowered rapidly in an emergency, to remove obstacles from the surface of the track, by means of the release of the same from the mechanism controlling it, which permits of the descent of said fender to within a short distance of the surface of the rail, thus preventing the car passing over the interposed obstruction, and at the same time brush the obstacle from the tracks, as will be more fully understood in its construction and operation from the following detailed description.

In the accompanying drawings which make a part of this specification, Figure 1, Sheet No. 1, is a plan view of the improved fender, and operating mechanism, connected with the end of a car. Fig. 2, is an end elevation. Fig. 3, Sheet No. 2, represents a side elevation showing the fender held in its elevated position. Fig. 4, represents a longitudinal section of the framework of the car, with the fender in section, showing the operating mechanism. Fig. 5, represents a side elevation showing the fender released from its elevated position and lowered to the tracks.

Like letters of reference in all the figures indicate the same parts.

A, represents a portion of the platform of a railway car. B, the axle, and C, C, a pair of wheels fast thereon.

D, is the track, or road bed.

E, is the fender, which is constructed of

sheet metal, of the usual form incident to railway cars, with its apex protruding forward in a central line longitudinally with the body of the car, the rigidity of its superficial area being increased by the braces *a*, extending to the bar, or rod *b*. The inner ends of these braces have pivotal connection with the rod *b'*, and through the intermediate arms *c*, *c*, to the rod *b''*, which is capable of partial rotary movement in the bearings *d*, *d*, which have sliding movement on the side rods F, F, which are rigidly connected at their ends to the sides of the platform, and the truck of the car.

G, G', are helical springs which slide freely over the rods F.

H, is an auxiliary semi-elliptical spring whose center is attached to the bar, or rod *b*, and whose free ends bear against the inner surface of the fender E, the object of this spring is to present a resistance to the action of the bell crank lever J, whose upper and free end bears against the end of the stop plate K, secured to the under side of the platform A, of the car.

L, is a vertical push rod, whose upper end extends through and above the platform, and is maintained in its elevated position by means of the helical spring *h*, which surrounds it, this rod has a foot *j*, upon its lower end, arranged at right angles to said rod, which rests upon the surface of the upper end of the elbow *k*, of the bell crank lever J.

N are a series of cone-shaped rollers, which revolve on bearings *l*, connected to the rod P the object of these rollers being to permit of the free passage of the fender over the tracks, when in its lowered position during the turning of curves in the road bed.

The operation is as follows: The fender being drawn forward into the position shown in Fig. 3, of the drawings, with the elbow *k*, of the bell crank lever J, resting against the forward end of the stop plate K, which retains the fender in its forward and elevated position. When it is desired to permit of the descent of the fender, the operator presses his foot upon the upper and exposed end of the push rod L, that extends above the surface of the platform A, (and is held up by means of the spring *h*) which in the descent of said rod causes the foot, or cross piece *j*, on its lower

end to press downward upon the adjoining
 end of the elbow *k*, of the bell crank lever J,
 thus freeing said lever from connection with
 the plate K, when the resiliency, or expan- 5
 sion of the helical springs which have been
 confined during the elevation of the fender,
 causes them to open and carry the fender to
 its lower position, as seen in Fig. 5, of the
 drawings,—the rollers N, permitting the fen- 10
 der to travel easily over the tracks, the prox-
 imity of the lower edge of the fender to the
 surface of the road bed, preventing any object
 from reaching the wheels of the car; by push-
 ing the obstruction forward and to one side. 15
 The main object of the forward vertical
 springs F, is to allow freedom of movement
 of the fender in the oscillating motions of the
 car. Pressure exerted upon the lower edge
 of the fender by reason of the resistance of an
 20 obstruction, will cause its withdrawal from
 the upward, and retained position upon the
 plate K, and cause it to descend to the level
 of the track.

I claim as my invention and desire to secure
 25 by Letters Patent—

1. In combination with a platform of the
 body of a railway car, the fender E, actuated
 in its elevated and depressed movements by
 the springs G, G', on the rods F, substantially
 30 in the manner herein shown and described.

2. The fender E, of a railway car, actuated

by the springs G, G', on the rods F, the plate
 K, the bell crank lever J, having elbow *k*, the
 rod L, with the foot *j*, and the spring *h*, sub- 35
 stantially in the manner and for the purpose
 herein shown and described.

3. A fender for railway cars, capable of ver- 40
 tical movements to elevate, or depress the
 same to, or from the railway surface, in com-
 bination with the helical springs G, G', mov-
 ing on the side rods F; the stop plate K, bell
 crank lever J, having elbow *k*, and the push
 rod L, provided with the foot *j*, substantially
 as herein shown and described, for the pur- 45
 pose set forth.

4. The auxiliary semi-elliptical spring H, in
 combination with the fender of a railway car,
 for presenting resistance to the bell crank le- 50
 ver J, when the fender is in an elevated posi-
 tion and for causing an oscillating motion of
 the same when lowered, for forcing an ob-
 structive body to the side of the car track,
 substantially in the manner herein described.

5. The frame work, or carrier for the fender
 E consisting of the V shaped rod *b*, supported 55
 in suitable bearings, and sliding on the rods
 F, provided with cone-shaped wheels N, sub-
 stantially as herein shown and described.

CHARLES R. HALL.

Witnesses:

THOMAS J. BEWLEY,
 ARNOLD KATZ.