



(12) **EUROPEAN PATENT APPLICATION**

(43) Date of publication:
17.10.2007 Bulletin 2007/42

(51) Int Cl.:
H05B 3/00 (2006.01) H05B 3/28 (2006.01)

(21) Application number: **07425197.6**

(22) Date of filing: **03.04.2007**

(84) Designated Contracting States:
AT BE BG CH CY CZ DE DK EE ES FI FR GB GR HU IE IS IT LI LT LU LV MC MT NL PL PT RO SE SI SK TR
 Designated Extension States:
AL BA HR MK YU

(71) Applicant: **ALPER srl**
36060 Romano d'Ezzellino, VI (IT)

(72) Inventors:
 • **Ragazzon, Daniele**
31030 Borso del Grappa Treviso (IT)
 • **Bresolin, Valerio**
36020 Pove del Grappa Vicenza (IT)

(30) Priority: **11.04.2006 IT VE20060022**

(54) **Radiant panel for the heating of environments**

(57) In a panel (10) for the heating of environments comprising a radiant covering element (20) and film re-

sistive heating means (30), said radiant covering element (20) is a stone or ceramic slab.

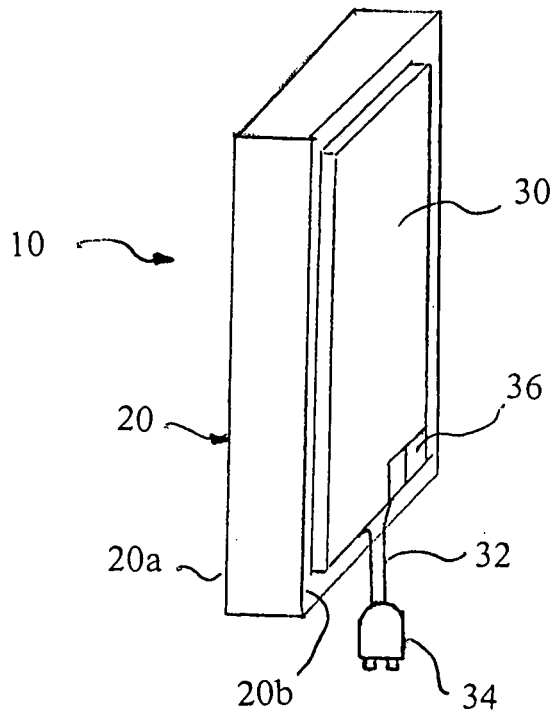

Fig. 1

Description

[0001] The present invention relates to a panel for the heating of environments made up of a radiant element on the rear surface on which there are heating resistive elements.

[0002] Heating panels of this type are known where a radiant element consists of a steel plate or metal sheet having a front surface, with a possible decoration in order to embellish the panel, and a rear surface onto which there are heating resistive elements.

[0003] The heating elements are essentially electrical wire resistances or film resistive elements fed by the standard voltage of an electrical system, i.e. 220-240V.

[0004] By electrically feeding the resistive elements, these elements warm due to the Joule effect, and transmit the heat to the steel plate that, due to its well-known heat conductive propriety, it warms and irradiates heat into the environment.

[0005] Considering that the temperature reached by the resistive elements is about 90 °C and that the steel, or whatever the metallic material is, is a good conductor of heat, the outer surface of the steel plate reaches a temperature of approximately 80 °C, an ideal temperature for heating. In fact, this temperature is similar to those of the radiators, thus allowing an efficient heating of the environment, but at the same time, avoiding burns in case of accidental or brief physical contact.

[0006] Although these heating panels are efficient, they have several drawbacks.

[0007] In fact, the metal is also a good conductor of electricity and, since the heating resistive elements are fed by the system electrical voltage of 220-240V, there are electrical risks due to the accidental contacts with parts in tension, in case failures or malfunctionings of the panel should occur.

[0008] This requires that appropriate precautions be taken, as well as the minimum safety measures in order to assure one's safety.

[0009] For example, it is necessary to connect the metallic plate to the ground so that, if the radiant element should come into contact with electrical parts under tension due to malfunctionings or failures of the insulating protection of the radiant element, because of the operation of the electrical safety devices (such as the residual current circuit-breaker), the electrical feeding is immediately switched off and people's safety is assured.

[0010] In this maner, the metallic plate is not able to reach dangerous voltages for people, however, other problems arise.

[0011] In fact, since the feeding voltage and thus the generated electric current are alternate, there are capacitive leakage currents. Bear in mind that the resistive heating element, whatever it is, is made of a real and proper resistance and of an insulating protective element. Therefore, the panel acts exactly as if it were a condenser or a capacitor where one plate is the steel plate and the other one is the electrical resistance, whereas the die-

lectric material interposed between the two plates is the insulating protective element.

[0012] Then, there are continuous leakages of electric currents towards the ground that may cause even the operation of the safety devices, such as the residual current circuit-breaker, which interrupting the feeding of the whole electrical installation, causes serious problems to the user.

[0013] Another drawback is due to the fact that the metallic plate is thin and that the specific heat of the metallic material is very low, therefore the thermal capacity for accumulating heat is extremely reduced. Then, as soon as the feeding of the panel is switched off, the emission of the heat is interrupted, thus causing an unpleasant sensation of cold in the room.

[0014] In order to overcome this drawback, elements able to accumulate heat are used, such as an oil container since oil has a high specific heat.

[0015] These devices make the radiant panel more complex and, they do not solve the above-mentioned problem efficiently.

[0016] The aim of the present invention is to make a panel for the heating of environments which is able to overcome the drawbacks described in the above-mentioned prior art.

[0017] In particular, a panel which is simple in construction and efficient in the operation. Moreover, it does not have electrical risks for people, even in case of failures and malfunctionings. It must have a sufficient thermal capacity in order to accumulate heat and then be able to release it when the panel is not electrically fed. The panel must also be able to withstand thermal shocks to which it is subjected.

[0018] Another aim is to obtain a heating panel which is very aesthetically appealing.

[0019] These and other aims are achieved by a panel for the heating of environments of the initially described type, comprising a radiant covering element having a front radiant surface opposite a rear surface and film resistive heating means applied onto said rear surface of said radiant covering element, characterized in that said radiant covering element is a stone or ceramic slab.

[0020] Thanks to the propriety of the stone or ceramic material, namely a material with a low electrical conductivity and that is an electrically insulating material, there is no electrical risk for people, even in the event that the covering slab of stone or ceramic material should come into contact with electrical parts under tension.

[0021] The panel is so intrinsically safe and thus does not need any kind of expedient or electrical safety device in order to ensure people's safety whatever occurs.

[0022] Furthermore, the stone or the ceramic material has a specific heat quite high, then it easily accumulates heat for releasing it in case of necessity when the panel is not for a moment electrically fed, thus operating as a thermal accumulator. Therefore, the new panel does not require any kind of device for accumulating heat, since it is sufficient the heat accumulated in the stone or ce-

ramic material.

[0023] In particular, the stone or ceramic slab has a thickness between 3mm and 3cm., preferably 1cm, in order to ensure the maximum safety from the electrical point of view and an optimum capacity for accumulating heat.

[0024] Usually, materials which are bad conductors of electricity are also bad conductors of heat, such as the stone or ceramic material which is not a good conductor of heat, in contrast, for example with the metallic materials.

[0025] However, by doing tests, it has nevertheless been discovered that such a heating panel is efficient from the thermal point of view, since by electrically feeding the resistive heating means, the radiant covering element easily reaches the desired temperature.

[0026] It can be noted that by using a stone or ceramic material slab, the panel is much more physically attractive.

[0027] These and other aims will be more evident by the following detailed description provided for illustrative purposes with reference to the enclosed drawings, wherein:

- fig. 1 is a perspective view of a heating panel for environments;
- fig. 2 is a perspective view of a complete heating panel obtained from the panel of figure 1.

[0028] In fig 1, a heating panel for environments is entirely indicated with reference 10 comprising a stone or ceramic slab 20 and a film resistive heating element 30.

[0029] The stone or ceramic slab 20 has a radiant front surface 20a and an opposite rear surface 20b where the resistive heating element 30 is applied.

[0030] The stone slab may be of natural stone, such as marble, granite, porphyry and so on, but more preferably an agglomerate stone slab.

[0031] An agglomerate stone slab is usually obtained by a process which consists of a first step of mixing to form a mix made up of a granular inert material, an organic or inorganic binder and a filler. These materials are intimately mixed together in order to obtain a homogeneous mix. The next step consists in distributing the mix thus prepared in a mould and, at last, the mix is compacted by a press (which is optionally placed into a vacuum room) and laying the mould on a vibrating plate. Finally, the compacted slab undergoes a hardening step by means of catalysis of the organic binder (such as a resin) or setting of the inorganic binder such as cement.

[0032] An agglomerate stone slab is preferred to a natural stone slab, since it has a homogeneous structure and there is no defects. Therefore, it is extremely resistant both to mechanical stresses and thermal shocks, in contrast with what occurs with natural stone where there are always flaws such as cavities and cracks which make the stone slab very brittle. Moreover, the use of a binder, makes the agglomerate stone slab more resistant.

[0033] A stone or ceramic slab has a thickness between 3mm and 3 cm, but preferably a thickness of 1 cm. Obviously, the stone or ceramic slab may have different dimensions, both in length or in width.

[0034] The film heating resistive element 30 is composed of pellicular resistive elements of "etched foiled" or PTF type (polymer thick film); the latter is formed by a lower layer of insulating material which forms the support on which, by means of depositing methods, resistive ink is applied which is covered by an upper layer of insulating material too.

[0035] The resistive ink layer is laid down in strips and may have characteristics of PTC type (positive temperature coefficient) whereby as the temperature increases, the electric resistance value increases, thus limiting by itself the current intensity avoiding dangerous overheating.

[0036] The resistive heating element 30 is applied on the stone or ceramic slab 20 by adhesive means, that is a tape which is adhesive on both sides, which is previously applied to the heating element 30. Subsequently, the surface of heating element 30 with the adhesive tape is applied on the rear surface 20b of the slab 20.

[0037] The surface of the resistive heating element 30 has an area essentially equal to the area of the rear surface 20b of the stone or ceramic slab 20, so as to efficiently heat the slab 20 on the whole surface.

[0038] Two electric wires 32 come out from the resistive heating element 30 and they are connected to an electric plug 34 which, when it is connected to an electric energy source, usually 220-240V, electrically feed the panel 10.

[0039] There is also a switch 36 which allows to feed the panel 10 or to interrupt the electric feeding.

[0040] Finally, in order to maintain a regular room temperature, the panel 10 is provided with an adjustable thermostat, not represented in the figures.

[0041] For the operation of the panel 10, it is sufficient to connect the plug 34 into any electric socket and to turn the switch 36 on.

[0042] In this way, the heat generated by the electric resistance contained in the resistive heating element 30 is transferred to the stone or ceramic slab 20 which irradiates it in the environment by means of the front radiant surface 20a.

[0043] As already stated, thanks to the low electric conductivity of the stone or ceramic slab, there is no electric risk to the user if, due to a failure, there should be an accidental direct contact between the resistive heating element 30 and the slab 20. Moreover, the stone or ceramic slab is able to accumulate sufficient heat and then, to release it when the feeding of the panel is interrupted, so acting as a thermal capacity for making the temperature regular and then more uniform.

[0044] The above described panel 10 is ready to be used and, it does not need further elements or work, since it is only necessary to fix it to a wall or, if there are suitable supports, it can be laid on the floor.

[0045] Then, the panel is very simple to construct, very resistant and attractive.

[0046] In figure 2 a heating panel 50 is represented according to a second variant of the invention.

[0047] The panel 50 is obtained by joining the above described panel 10 with an insulating slab 60 which is applied on the resistive heating element 30.

[0048] The insulating slab 60 may be made, for example, of wood, plastic or fibrous materials (such as mineral wool, glass wool or fiberglass) or others.

[0049] In this manner, the transmission of heat occurs almost entirely towards the stone or ceramic slab 20, thus increasing the thermal efficiency of the panel.

[0050] The insulating slab 60 is joined together by using, for example, a biadhesive tape, as already described for applying the resistive heating element 30 on the stone or ceramic slab 20.

[0051] The panel 10 or 50, as above described, is represented in the figures in a flat arrangement, but it is possible to obtain a curve panel instead of a flat panel, by manufacturing and using a curve agglomerate stone slab.

[0052] It is evident that variations or changes conceptually or functionally equivalent fall within the scope of the present invention.

[0053] For example, it is possible to employ a resistive heating element divided in two or more elements, so as to vary the power of the panel according to the number of heating elements which are fed.

[0054] Furthermore, in order to fix the resistive heating element to the stone or ceramic slab or to fix the insulating slab, it is possible to employ other methods such as direct glueing.

Claims

1. Panel (10) for the heating of environments comprising a radiant covering element (20) having a front radiant surface (20a) opposite a rear surface (20b) and film resistive heating means (30) applied onto said rear surface (20b) of said radiant covering element (20), **characterized in that** said radiant covering element is a stone or ceramic slab (20).
2. Panel according to claim 1, **characterized in that** said stone slab (20) is an agglomerate stone slab.
3. Panel according to claim 1 or 2, **characterized in that** said stone or ceramic slab (20) has a thickness between 3mm and 3cm.
4. Panel according to any of the previous claims, **characterized in that** said resistive heating means (30) are essentially applied on the entire rear surface (20b) of said stone or ceramic slab (20).
5. Panel according to any of the previous claims, **char-**

acterized in that said resistive heating means (30) are applied on the rear surface (20b) of said stone or ceramic slab (20) by glueing means.

6. Panel according to claim 5, **characterized in that** said glueing means consists of a biadhesive tape.
7. Panel according to any of the previous claims, **characterized in that** said film resistive heating means (30) comprise at least one resistance PTC.
8. Panel according to claims 7, **characterized in that** said PTC film resistive heating means (30) are fed by an electric voltage of 220-240V.
9. Heating panel (50) comprising a panel (10) according to any of the previous claims, **characterized in that** it comprises an insulating slab (60) applied on said film resistive heating means (30) on the opposite part of the stone or ceramic slab (20), so that said film resistive heating means (30) are interposed between said stone or ceramic slab (20) and said insulating slab (60).
10. Heating panel according to claim 10, **characterized in that** said insulating slab (60) is a wood or plastic slab or a slab made up of fibrous materials.
11. Heating panel (10 or 50) according to any of the previous claims, **characterized in that** said stone or ceramic slab (20) is flat.
12. Heating panel (10 or 50) according to any of the previous claims 1 to 10, **characterized in that** said stone or ceramic slab (20) is curved.
13. Method for manufacturing a panel for heating of environments, **characterized in that** a stone or ceramic slab (20) is coupled with film resistive heating means (30).
14. Method according to claim 13, **characterized in that** said coupling is achieved by means of a biadhesive tape.
15. Method according to claim 13, **characterized in that** said film resistive heating means (30) are coupled with an insulating slab (60), so that said said film resistive heating means (30) are interposed between said stone or ceramic slab (20) and said insulating slab (60).

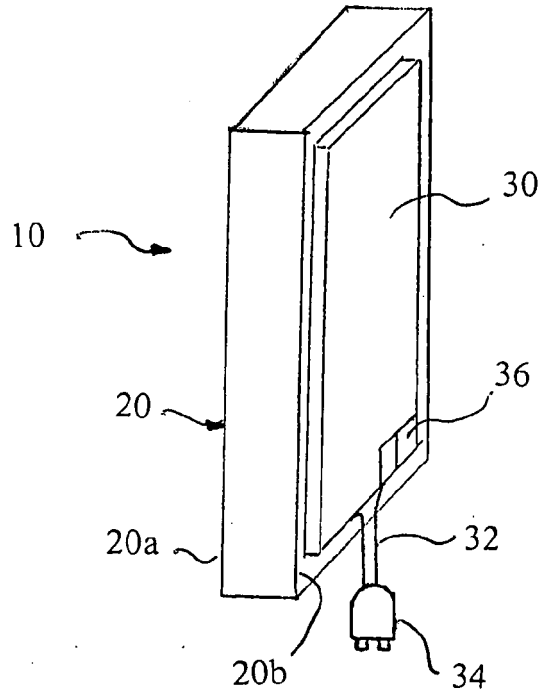

Fig. 1

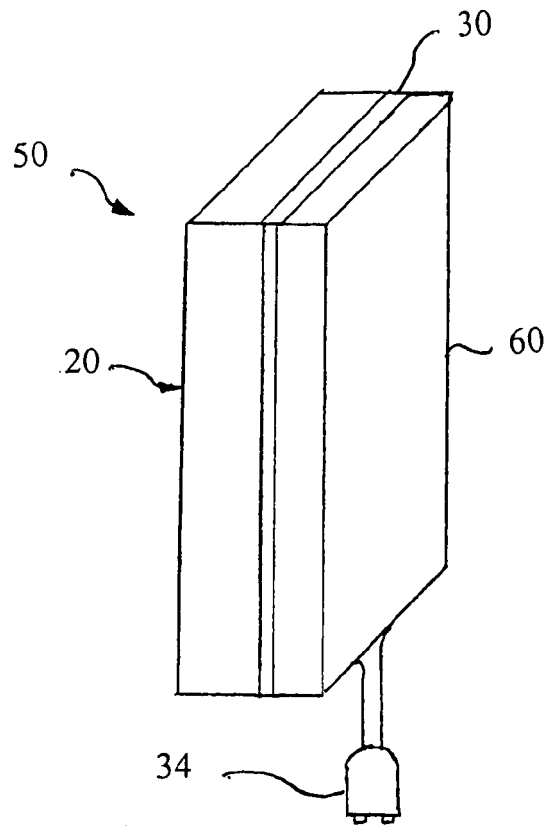

Fig. 2