



US009392374B2

(12) **United States Patent**
Hirayama et al.

(10) **Patent No.:** **US 9,392,374 B2**
(45) **Date of Patent:** ***Jul. 12, 2016**

(54) **ACOUSTIC GENERATOR, ACOUSTIC GENERATION DEVICE, AND ELECTRONIC DEVICE**

(71) Applicant: **KYOCERA Corporation**, Kyoto-shi, Kyoto (JP)

(72) Inventors: **Takeshi Hirayama**, Kirishima (JP);
Shuichi Fukuoka, Kirishima (JP);
Noriyuki Kushima, Kirishima (JP);
Saneaki Akieda, Nagoya (JP); **Hiroshi Ninomiya**, Kirishima (JP)

(73) Assignee: **Kyocera Corporation**, Kyoto-shi, Kyoto (JP)

(*) Notice: Subject to any disclaimer, the term of this patent is extended or adjusted under 35 U.S.C. 154(b) by 0 days.

This patent is subject to a terminal disclaimer.

(21) Appl. No.: **14/410,816**

(22) PCT Filed: **Jul. 31, 2013**

(86) PCT No.: **PCT/JP2013/070806**

§ 371 (c)(1),

(2) Date: **Dec. 23, 2014**

(87) PCT Pub. No.: **WO2014/024756**

PCT Pub. Date: **Feb. 13, 2014**

(65) **Prior Publication Data**

US 2015/0201281 A1 Jul. 16, 2015

(30) **Foreign Application Priority Data**

Aug. 10, 2012 (JP) 2012-179066

(51) **Int. Cl.**
H04R 17/00 (2006.01)
H04R 7/10 (2006.01)

(52) **U.S. Cl.**
CPC . **H04R 17/00** (2013.01); **H04R 7/10** (2013.01)

(58) **Field of Classification Search**
CPC H04R 2440/00–2440/07; H04R 17/02; H04R 2217/00–2217/03; H04R 7/04
USPC 381/152, 173, 190, 431
See application file for complete search history.

(56) **References Cited**

U.S. PATENT DOCUMENTS

6,278,790 B1 * 8/2001 Davis et al. 381/190
2003/0048914 A1 * 3/2003 Yi et al. 381/190

(Continued)

FOREIGN PATENT DOCUMENTS

JP 2012-015760 A 1/2012
JP 2012-060513 A 3/2012
JP 2012-110018 A 6/2012

OTHER PUBLICATIONS

International Search Report, PCT/JP2013/070806, Sep. 30, 2013, 1 pg.

Primary Examiner — Suhan Ni

(74) Attorney, Agent, or Firm — Volpe and Koenig, P.C.

(57) **ABSTRACT**

An acoustic generator according to an aspect of an embodiment includes a frame, a vibration body, and a piezoelectric vibration element. The vibration body is provided at an inner side of the frame. The piezoelectric vibration element is provided on the vibration body. The vibration body has a configuration in which a thin plate-like first portion and a thin plate-like second portion having different elastic moduli are laminated.

20 Claims, 6 Drawing Sheets

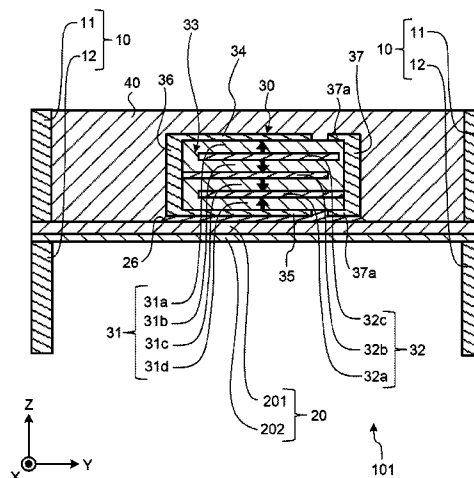
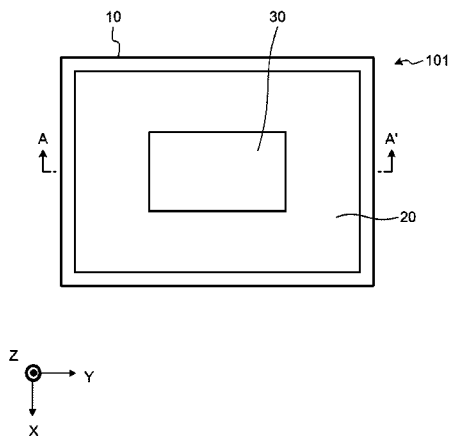

(56)

References Cited

U.S. PATENT DOCUMENTS

2013/0094681 A1	4/2013	Fukuoka et al.	
2013/0322663 A1 *	12/2013	Melcher et al.	381/190
2014/0314255 A1	10/2014	Fukuoka et al.	
2012/0148073 A1 *	6/2012	Kim et al.	381/190

* cited by examiner

FIG.1A

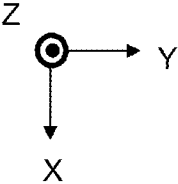
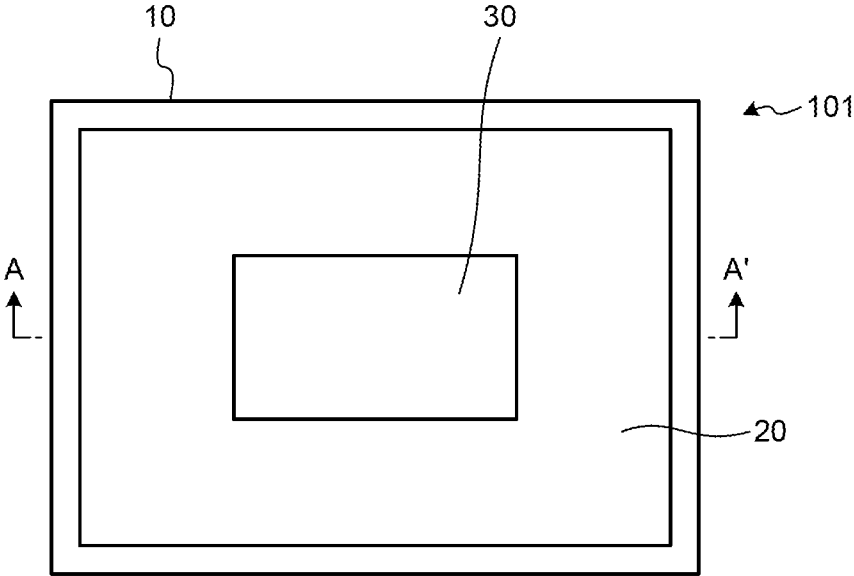

FIG. 1B

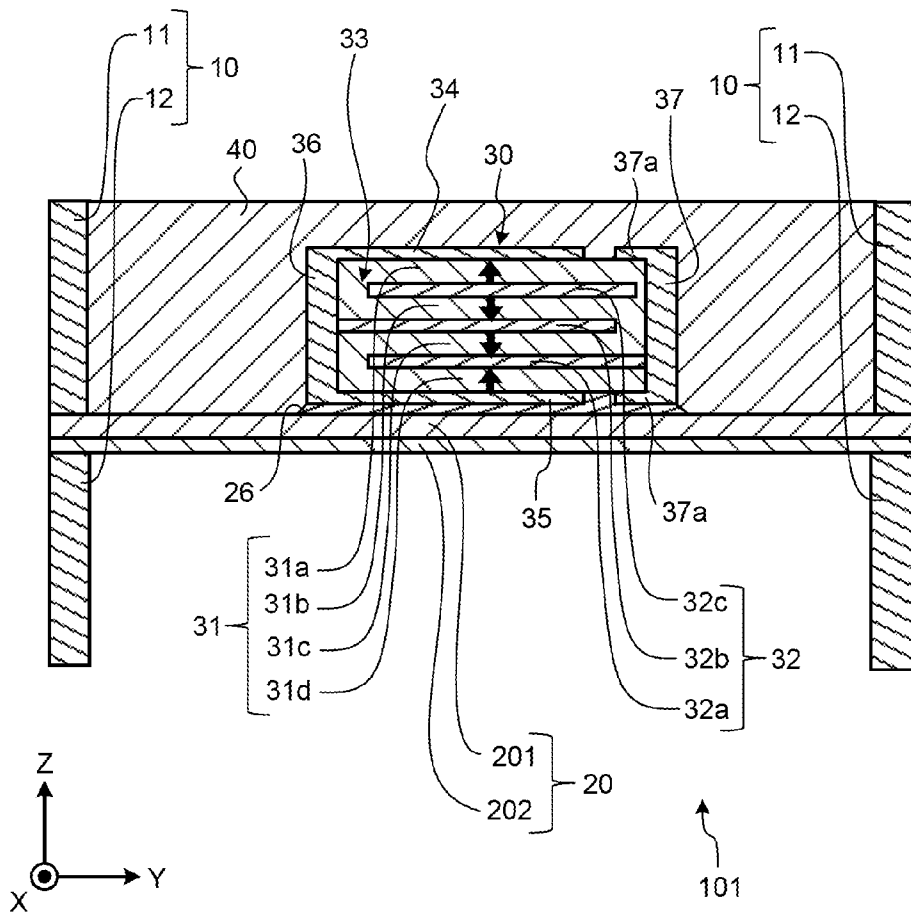

FIG.2A

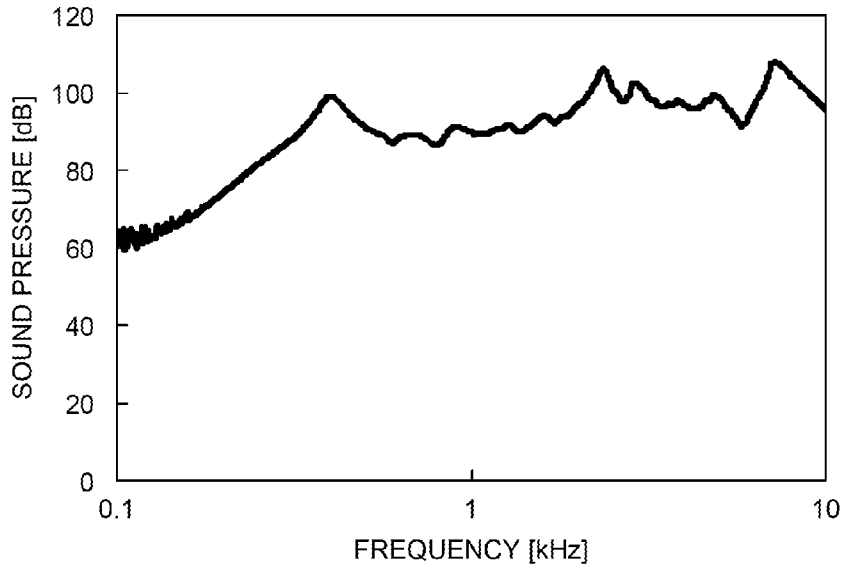

FIG.2B

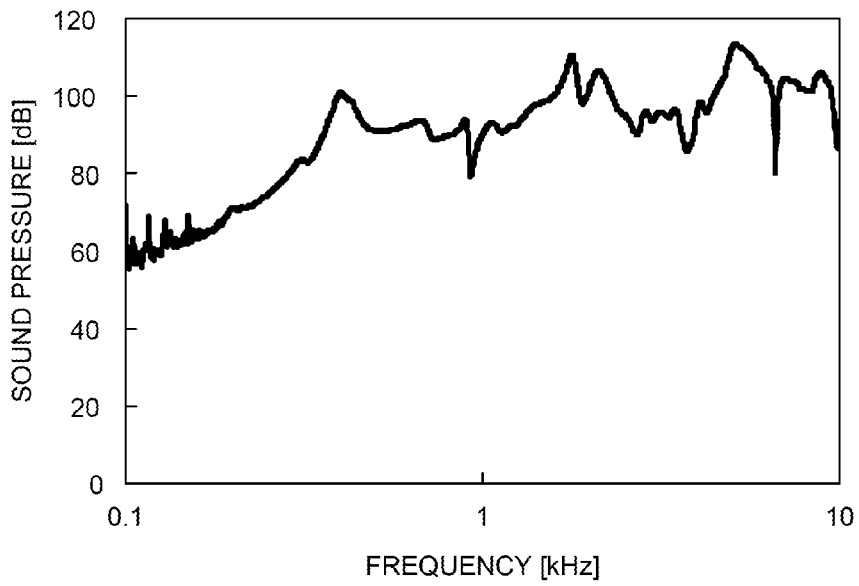

FIG.3

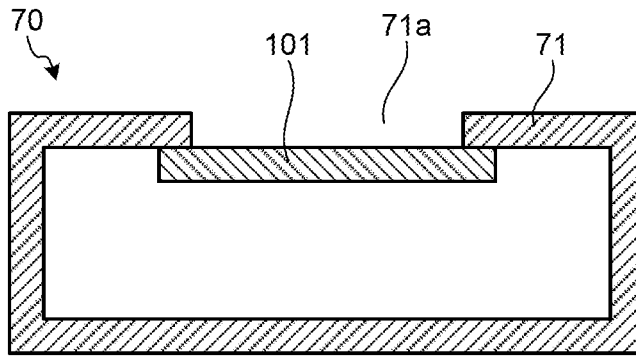

FIG.4

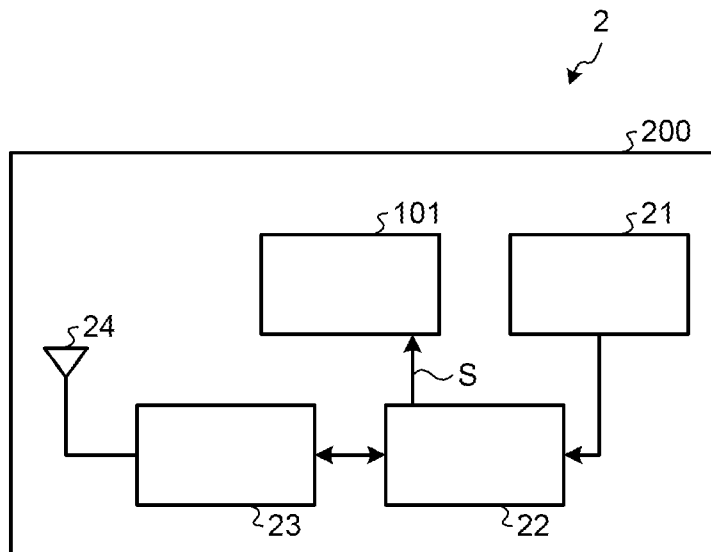

FIG.5A

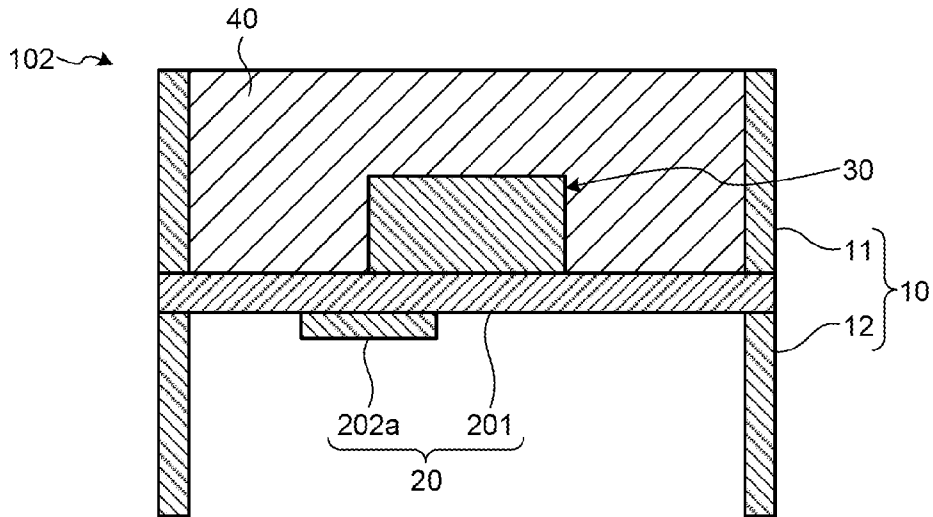

FIG.5B

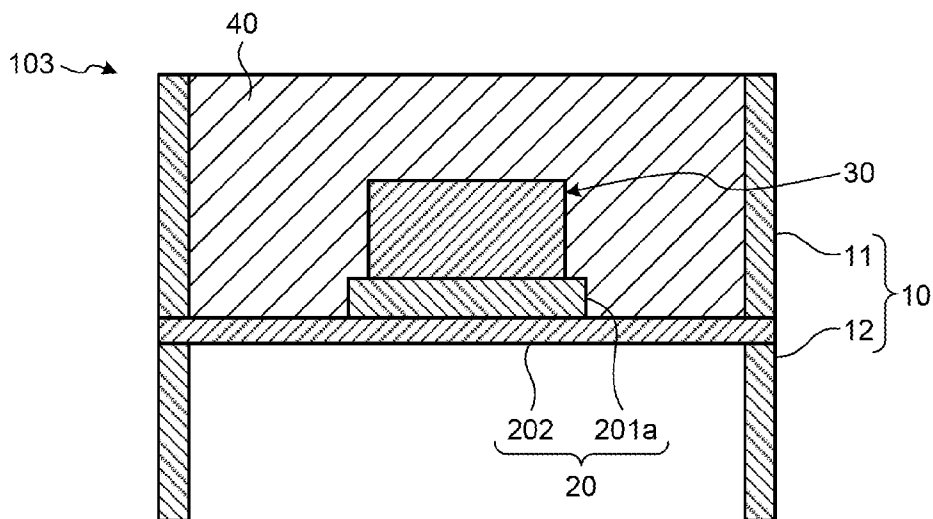

FIG. 6

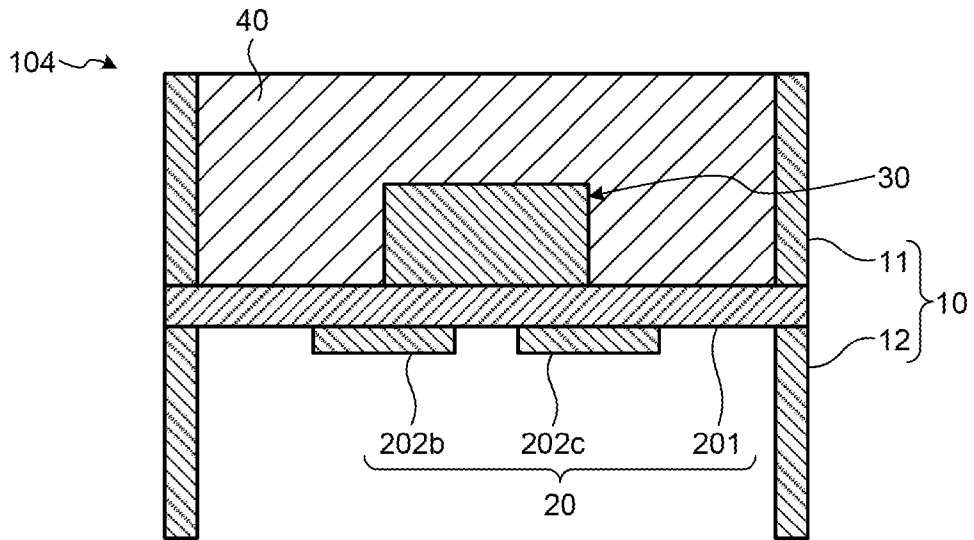
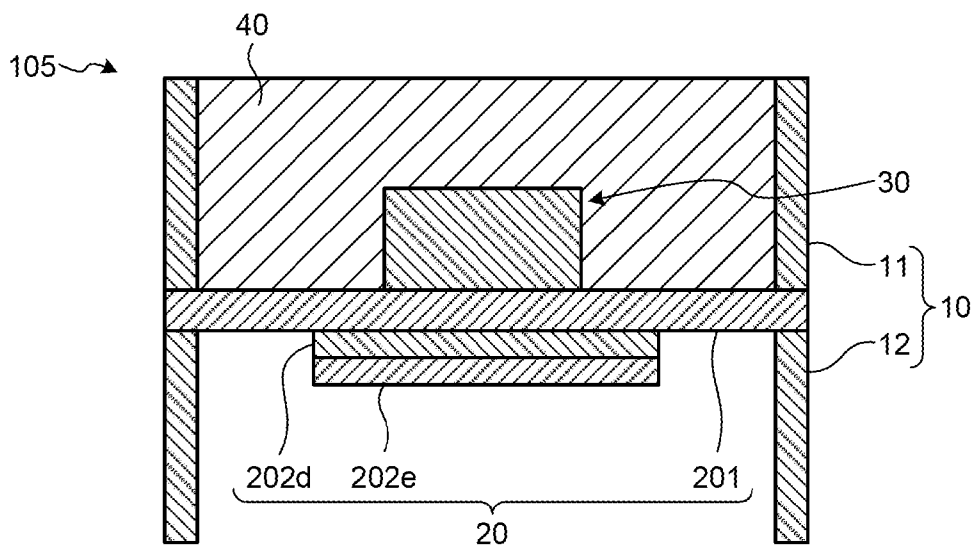

FIG. 7



1

ACOUSTIC GENERATOR, ACOUSTIC GENERATION DEVICE, AND ELECTRONIC DEVICE

CROSS-REFERENCE TO RELATED APPLICATIONS

This application is national stage application of International Application No. PCT/JP2013/070806, filed on Jul. 31, 2013, which designates the United States, incorporated herein by reference, and which claims the benefit of priority from Japanese Patent Application No. 2012-179066, filed on Aug. 10, 2012, the entire contents of which are incorporated herein by reference.

FIELD

The disclosed embodiments relate to an acoustic generator, an acoustic generation device, and an electronic device.

BACKGROUND

Conventionally, piezoelectric speakers have been known as small-sized thin acoustic generators. As the conventional piezoelectric speakers, there is exemplified a piezoelectric speaker including a rectangular frame, a film provided on the frame in a tension manner, and a piezoelectric vibration element provided on the film (for example, see Patent Literature 1).

CITATION LIST

Patent Literature

Patent Literature 1: Japanese Patent Application open No. 2012-60513

SUMMARY

Technical Problem

The piezoelectric speaker disclosed in Patent Literature 1, however, has the following problem. That is, peaks (portions having sound pressure higher than the periphery) and dips (portions having sound pressure lower than the periphery) are generated in frequency characteristics of the sound pressure due to a resonance phenomenon, and drastic frequency-related variation of the sound pressure occurs. In addition, there is a problem that frequency-related variation also occurs in average sound pressure obtained by averaging the peaks and the dips because distribution of the peaks due to the resonance phenomenon is uneven and so on.

Solution to Problem

An acoustic generator according to an aspect of an embodiment includes a frame, a vibration body, and a piezoelectric vibration element. The vibration body is provided at an inner side of the frame. The piezoelectric vibration element is provided on the vibration body. The vibration body has a configuration in which a thin plate-like first portion and a thin plate-like second portion having different elastic moduli are laminated.

BRIEF DESCRIPTION OF DRAWINGS

FIG. 1A is a plan view schematically illustrating an acoustic generator according to a first embodiment.

2

FIG. 1B is a cross-sectional view cut along line I-I' in FIG. 1A.

FIG. 2A is a graph illustrating an example of frequency dependence of sound pressure in the acoustic generator in the first embodiment.

FIG. 2B is a graph illustrating an example of frequency dependence of sound pressure in an acoustic generator according to a comparison example.

FIG. 3 is a view for explaining the configuration of an acoustic generation device according to a second embodiment.

FIG. 4 is a diagram for explaining the configuration of an electronic device according to a third embodiment.

FIG. 5A is a cross-sectional view schematically illustrating an acoustic generator according to a fourth embodiment.

FIG. 5B is a cross-sectional view schematically illustrating an acoustic generator according to a fifth embodiment.

FIG. 6 is a cross-sectional view schematically illustrating an acoustic generator according to a sixth embodiment.

FIG. 7 is a cross-sectional view schematically illustrating an acoustic generator according to a seventh embodiment.

DESCRIPTION OF EMBODIMENTS

Hereinafter, embodiments of an acoustic generator, an acoustic generation device, and an electronic device that are disclosed by the present application will be described with reference to the accompanying drawings. It should be noted that the respective embodiments as will be described below do not limit the invention.

First Embodiment

The configuration of an acoustic generator **101** according to a first embodiment will be described with reference to FIG. 1A and FIG. 1B. FIG. 1A is a plan view illustrating the acoustic generator **101** in the first embodiment when seen from the thickness direction (direction perpendicular to the main surface and +Z direction in FIG. 1A) of a vibration body **20**. FIG. 1B is a cross-sectional view cut along line I-I' in FIG. 1A. In order to facilitate understanding, FIG. 1A illustrates a state where a resin layer **40** is seen through and FIG. 1B illustrates the acoustic generator **101** while enlarging it in the Z-axis direction.

As illustrated in FIG. 1A and FIG. 1B, the acoustic generator **101** in the first embodiment includes a frame **10**, the vibration body **20** provided at the inner side of the frame **10**, a piezoelectric vibration element **30** provided on the vibration body **20**, and the resin layer **40**. The vibration body **20** has a configuration in which a thin plate-like first portion **201** and a thin plate-like second portion **202** having different elastic moduli are laminated.

The first portion **201** is made of a material having an elastic modulus different from that of a material of the second portion **202**, so that the elastic modulus of the first portion **201** is different from that of the second portion **202**. To be specific, the elastic modulus of the first portion **201** is set to be lower than that of the second portion **202**. Furthermore, the first portion **201** is made of a material having a mechanical Q value (mechanical quality factor) lower than that of a material of the second portion **202**. The mechanical Q value of the first portion **201** is set to be lower than that of the second portion **202**.

The first portion **201** can be made of various materials having a low elastic modulus and a low mechanical Q value, for example, resin or rubber. For example, a film formed by resin such as polyethylene and polyimide can be preferably

used as the first portion **201**. The thickness of the first portion **201** can be set to 10 to 200 μm , for example. It is desirable that the first portion **201** be formed by porous resin for improving sound quality and be formed to have a thickness larger than that of the second portion **202**. The difference in the thickness between the first portion **201** and the second portion **202** can be appropriately determined in accordance with desired sound pressure and sound quality.

The second portion **202** can be made of various materials having a high elastic modulus and a high mechanical Q value, for example, metal or ceramics. For example, the thickness of the second portion **202** can be set to 10 to 200 μm . Metal foil like aluminum foil can be preferably used as the second portion **202**, for example.

The frame **10** is configured by an upper frame member **11** and a lower frame member **12** having the same shape (rectangular shape). A peripheral edge portion of the vibration body **20** is interposed between the upper frame member **11** and the lower frame member **12** to be fixed. The peripheral edge portion of the vibration body **20** is supported by the frame **10** in a state where a portion of the vibration body **20** at the inner side of the frame **10** can vibrate. Thus, the frame **10** plays a role in holding the vibration body **20** such that the vibration body **20** can vibrate, and fixes the vibration body **20** in a state where a predetermined tensile force is applied to the vibration body **20**. That is to say, the vibration body **20** is provided (stretched) at the inner side of the frame **10** in a state where the tensile force is applied thereto. This configuration provides the acoustic generator **101** including the vibration body **20** with small variation such as deflection even if it is used for a long period of time.

The material of the frame **10** is not particularly limited and various known materials such as metal, plastic, glass, ceramic, and wood can be used. Among the various known materials, for example, stainless can be preferably used because it is excellent in mechanical strength and corrosion resistance. The thickness of the frame **10** is not also particularly limited and can be set appropriately depending on situations. For example, the thickness of the frame **10** can be set to appropriately 100 to 1000 μm .

The upper and lower main surfaces of the piezoelectric vibration element **30** have rectangular plate-like shapes. The piezoelectric vibration element **30** includes a laminate body **33**, surface electrode layers **34** and **35**, and first to third external electrodes. The laminate body **33** is formed by alternately laminating four piezoelectric layers **31** (**31a**, **31b**, **31c**, **31d**) and three internal electrode layers **32** (**32a**, **32b**, **32c**). The surface electrode layers **34** and **35** are formed on the upper and lower surfaces of the laminate body **33**, respectively. The first to third external electrodes are provided on end portions of the laminate body **33** in the lengthwise direction (Y-axis direction).

This first external electrode **36** is arranged on an end portion of the laminate body **33** in the -Y direction and is connected to the surface electrode layers **34** and **35** and the internal electrode layer **32b**. This second external electrode **37** and this third external electrode (not illustrated) are arranged on an end portion of the laminate body **33** in the +Y direction with an interval therebetween in the X-axis direction. The second external electrode **37** is connected to the internal electrode layer **32a** and the third external electrode (not illustrated) is connected to the internal electrode layer **32c**.

Upper and lower end portions of the second external electrode **37** extend to the upper and lower surfaces of the laminate body **33** and folded external electrodes **37a** are formed thereon. These folded external electrodes **37a** are provided to

extend so as to be spaced from the surface electrode layers **34** and **35** by predetermined distances such that they do not make contact with the surface electrode layers **34** and **35** formed on the surfaces of the laminate body **33**. In the same manner, upper and lower end portions of the third external electrode (not illustrated) extend to the upper and lower surfaces of the laminate body **33** and folded external electrodes (not illustrated) are formed thereon. These folded external electrodes (not illustrated) are provided to extend so as to be spaced from the surface electrode layers **34** and **35** by predetermined distances such that they do not make contact with the surface electrode layers **34** and **35** formed on the surfaces of the laminate body **33**.

The piezoelectric layers **31** (**31a**, **31b**, **31c**, **31d**) are polarized in the directions as indicated by arrows in FIG. 1B. A voltage is applied to the first external electrode **36**, the second external electrode **37**, and the third external electrode such that the piezoelectric layers **31c** and **31d** expand when the piezoelectric layers **31a** and **31b** contract and the piezoelectric layers **31c** and **31d** contract when the piezoelectric layers **31a** and **31b** expand. Thus, the piezoelectric vibration element **30** is a bimorph-type piezoelectric element, and bends and vibrates in the Z-axis direction such that amplitude thereof changes in the Y-axis direction when an electric signal is input thereto.

Existing piezoelectric ceramics such as lead zirconate (PZ), lead zirconium titanate (PZT), Bi-layered compound, and a lead-free piezoelectric material like a tungsten bronze structure compound can be used as the piezoelectric layers **31**. The thicknesses of the piezoelectric layers **31** can be set appropriately in accordance with desired vibration characteristics. For example, the thicknesses of the piezoelectric layers **31** can be set to 10 to 100 μm from a viewpoint of driving at a low voltage.

The internal electrode layers **32** can be made of various existing conductive materials. For example, the internal electrode layers **32** can contain a metal component made of silver and palladium and a material component forming the piezoelectric layers **31**. The internal electrode layers **32** contain the ceramic component forming the piezoelectric layers **31**, so that stress due to difference in the thermal expansion between the piezoelectric layers **31** and the internal electrode layers **32** can be reduced. The internal electrode layers **32** may not contain the metal component made of silver and palladium or may not contain the material component forming the piezoelectric layers **31**.

The surface electrode layers **34** and **35** and the first to third external electrodes can be made of various existing conductive materials. For example, they can contain a metal component made of silver and a glass component. Thus, the surface electrode layers **34** and **35** and the first to third external electrodes contain the glass component, so that strong adhesion force can be provided between the surface electrode layers **34** and **35** and the first to third external electrode and the piezoelectric layers **31** and the internal electrode layers **32**. Note that they are not limited to contain the glass component.

Furthermore, the main surface of the piezoelectric vibration element **30** at the vibration body **20** side is bonded to the vibration body **20** with an adhesive **26**. The thickness of the adhesive **26** is desirably equal to or smaller than 20 μm , more desirably equal to or smaller than 10 μm . When the thickness of the adhesive **26** is equal to or smaller than 20 μm , vibration of the laminate body **33** is easy to be transmitted to the vibration body **20**.

The adhesive **26** can be formed, by curing well-known adhesives such as epoxy-based resin, silicone resin, and poly-

5

ester-based resin. As a method of curing the adhesive, any method of thermal curing, photo-curing, and anaerobic curing may be used. It should be noted that an adhesive material other than the adhesive, such as double-stick tape, may be used as the adhesive **26**.

Furthermore, in the acoustic generator **101** in the embodiment, a cover layer formed by the resin layer **40** covers at least a part of the surface of the vibration body **20**. To be specific, in the acoustic generator **101** in the embodiment, a resin is filled at the inner side of the upper frame member **11** so as to embed therein the vibration body **20** and the piezoelectric vibration element **30**, and the resin layer **40** is formed by the filled resin.

The resin layer **40** can be formed by epoxy-based resin, acryl-based resin, silicon-based resin, rubber, or the like. In consideration of reduction of the peaks and the dips, the resin layer **40** preferably covers the piezoelectric vibration element **30** completely but may not cover the piezoelectric vibration element **30** completely. Furthermore, the resin layer **40** may not necessarily cover the entire vibration body **20** and the resin layer **40** may be provided so as to cover a part of the vibration body **20** depending on cases. The thickness of the resin layer **40** can be appropriately set, for example, is set to approximately 0.1 mm to 1 mm. The resin layer **40** may not be provided depending on cases.

Thus, resonance of the vibration body **20** can be moderately damped by providing the resin layer **40** as described above. This can reduce the peaks and the dips in the frequency characteristics of the sound pressure that are generated due to the resonance phenomenon to be small, thereby reducing frequency-related variation of the sound pressure.

As described above, in the acoustic generator **101** in the embodiment, the vibration body **20** has a configuration in which the thin plate-like first portion **201** and the thin plate-like second portion **202** having different elastic moduli are laminated. This configuration can generate high-quality sound with small frequency-related variation of the sound pressure for the following reason. The sound pressure is high in a low frequency region with vibration of only the first portion **201** having a low elastic modulus and the sound pressure is high in a high frequency region with vibration of only the second portion **202** having a high elastic modulus. That is, it is considered that variation of the sound pressure in a wide frequency band can be reduced macroscopically by causing the vibration body **20** to have the configuration in which the first portion **201** and the second portion **202** are laminated.

In the acoustic generator **101** in the embodiment, the piezoelectric vibration element **30** is provided on the main surface of the vibration body **20** at the side of the first portion **201** having a relatively low elastic modulus and is attached to the first portion **201**. This configuration can prevent the sound pressure in a high-frequency region from being too high.

Furthermore, in the acoustic generator **101** in the embodiment, the piezoelectric vibration element **30** is provided on the main surface of the vibration body **20** at the side of the first portion **201** having a relatively low mechanical Q value and is attached to the first portion **201**. This configuration enhances an effect that the resonance is damped and can reduce the peaks and the dips in the frequency characteristics of the sound pressure that are generated due to the resonance phenomenon to be small, thereby reducing variation of the sound pressure in a narrow frequency range microscopically.

In the acoustic generator **101** in the embodiment, the thickness of the first portion **201** is set to be larger than that of the second portion **202**. This configuration can enhance an effect of the reduction in the variation of the sound pressure by the

6

first portion **201**. In addition, the thickness of the first portion **201** having a relatively low elastic modulus is set to be larger than that of the second portion **202**, thereby improving sound quality while keeping the mechanical strength.

In the acoustic generator **101** in the embodiment, the first portion **201** is made of resin and the second portion **202** is made of metal. This provides the acoustic generator **101** that is capable of generating high-quality sound, has high mechanical strength, and can be manufactured easily. Moreover, the first portion **201** is made of porous resin. This further enhances the effect that the resonance is damped and can further reduce the peaks and the dips in the frequency characteristics of the sound pressure that are generated due to the resonance phenomenon to be small, thereby reducing variation of the sound pressure in a narrow frequency range microscopically.

In the acoustic generator **101** in the embodiment, the entirety of the vibration body **20** has the configuration in which the first portion **201** and the second portion **202** are laminated. With this configuration, the entirety of the vibration body **20** can vibrate uniformly so as to generate higher-quality sound.

In the acoustic generator **101** in the embodiment, the resin is filled at the inner side of the upper frame member **11** so as to embed therein the vibration body **20** and the piezoelectric vibration element **30**, and the cover layer (resin layer **40**) is formed by the filled resin. That is to say, in the acoustic generator **101** in the embodiment, the cover layer further covers at least a part of the surface of the vibration body **20** at the side at which the piezoelectric vibration element **30** is arranged. This configuration further enhances the effect that the resonance is damped and can further reduce the peaks and the dips in the frequency characteristics of the sound pressure that are generated due to the resonance phenomenon to be small, thereby reducing variation of the sound pressure in a narrow frequency range microscopically.

FIG. 2A is a graph illustrating an example of frequency dependence of sound pressure in the acoustic generator **101** in the embodiment. FIG. 2B is a graph illustrating an example of frequency dependence of sound pressure in an acoustic generator in a comparison example. The acoustic generator in the comparison example has a configuration that is the same as that of the acoustic generator **101** in the embodiment other than a point that the vibration body **20** is formed by only one resin film. In the graphs as illustrated in FIG. 2A and FIG. 2B, the transverse axis indicates the frequency and the longitudinal axis indicates the sound pressure.

As will be obvious from comparison between FIG. 2A and FIG. 2B, the acoustic generator **101** in the embodiment can generate high-quality sound with small frequency-related variation of the sound pressure in comparison with the acoustic generator in the comparison example.

The magnitude relation between the elastic modulus of the first portion **201** and the elastic modulus of the second portion **202** is obtained as follows. For example, it is sufficient that the indentation hardness test is executed on each of the surfaces of the first portion **201** and the second portion **202** to measure elastic moduli of the respective surfaces and the magnitude relation thereof is compared. The indentation hardness test is a test in which an indenter is pressed into a surface of a material the elastic modulus of which is to be measured by gradually applying load, and then, the load is gradually cancelled so as to calculate hardness and the elastic modulus based on a relation between change in the load and change in a displacement amount of the indenter. For example, the indentation hardness test can be executed using various test machines (referred to as a hardness test machine, an indenta-

tion hardness test machine, or the like) like a hardness test machine DUH-211S manufactured by Shimadzu Corporation.

Next, an example of a method of manufacturing the acoustic generator **101** in the embodiment will be described. The piezoelectric vibration element **30** is prepared initially. First of all, a binder, a dispersant, a plasticizer, and a solvent are kneaded into powder of a piezoelectric material so as to produce slurry. As the piezoelectric material, any of lead-based and lead-free materials can be used.

Subsequently, a green sheet is produced by shaping the slurry into a sheet form. Then, conductive pastes are printed on the green sheet so as to form a conductive pattern serving as the internal electrode. Three green sheets on which the electrode patterns are formed are laminated on one another and a green sheet on which the electrode pattern is not printed is laminated thereon so as to produce a laminate molded body. Then, the laminate molded body is degreased, sintered, and cut to have a predetermined dimension so as to provide the laminate body **33**.

Thereafter, the outer peripheral portion of the laminate body **33** is processed if necessary. Conductive pastes for forming the surface electrode layers **34** and **35** are printed on both the main surfaces of the laminate body **33** in the laminate direction. Subsequently, conductive pastes for forming the first to third external electrodes are printed on both the end surfaces of the laminate body **33** in the lengthwise direction (Y-axis direction). Then, the electrodes are baked at a predetermined temperature. In this manner, the piezoelectric vibration element **30** as illustrated in FIG. 1A and FIG. 1B can be provided.

Thereafter, in order to give piezoelectric property to the piezoelectric vibration element **30**, a direct-current voltage is applied thereto through the first to third external electrodes so as to polarize the piezoelectric layers **31** of the piezoelectric vibration element **30**. The DC voltage is applied such that the polarization is performed in the directions as indicated by the arrows in FIG. 1B.

Then, the vibration body **20** is prepared and the outer peripheral portion of the vibration body **20** is interposed between the frame members **11** and **12** so as to be fixed in a state where a tensile force is applied to the vibration body **20**. Thereafter, the adhesive forming the adhesive **26** is applied onto the vibration body **20**. The piezoelectric vibration element **30** at the surface electrode **34** side is pressed against the vibration body **20**. Then, the adhesive is cured by irradiating it with heat or ultraviolet rays. The resin before cured is made to flow to the inner side of the frame member **11**, and is cured so as to form the resin layer **40**. In this manner, the acoustic generator **101** in the embodiment can be manufactured.

Second Embodiment

Next, the configuration of an acoustic generation device **70** according to a second embodiment will be described. FIG. 3 is a view illustrating an example of the configuration of the acoustic generation device **70** including the acoustic generator **101** according to the above-mentioned first embodiment. In FIG. 3, only constituent components necessary for explanation are illustrated and the detail configuration and common constituent components of the acoustic generator **101** are not illustrated.

The acoustic generation device **70** in the embodiment is an acoustic generation device such as a what-is-called speaker. As illustrated in FIG. 3, for example, the acoustic generation device **70** includes a housing **71** and the acoustic generator **101** attached to the housing **71**. The housing **71** has a box-like

shape of rectangular parallelepiped and has an opening **71a** on one surface. For example, the housing **71** can be made of a known material such as plastic, metal, and wood. The housing **71** is not limited to have the box-like shape of rectangular parallelepiped and may have various shapes such as a circular cylindrical shape and a frustum shape.

The acoustic generator **101** is attached to the opening **71a** of the housing **71**. The acoustic generator **101** corresponds to the acoustic generator in the above-mentioned first embodiment and description of the acoustic generator **101** is omitted. The acoustic generation device **70** having the configuration generates sound using the acoustic generator **101** generating high-quality sound, thereby generating high-quality sound. The acoustic generation device **70** can resonate the sound generated from the acoustic generator **101** in the housing **71** so as to increase the sound pressure in a low-frequency band, for example. A place at which the acoustic generator **101** is attached can be set freely. The acoustic generator **101** may be attached to the housing **71** through another member.

Third Embodiment

Next, the configuration of an electronic device according to a third embodiment will be described. FIG. 4 is a view illustrating an example of the configuration of an electronic device **2** including the acoustic generator **101** in the above-mentioned first embodiment. In FIG. 4, only constituent components necessary for explanation are illustrated and the detail configuration and common constituent components of the acoustic generator **101** are not illustrated. The electronic device **2** includes a case **200**, the acoustic generator **101** provided in the case **200**, and an electronic circuit connected to the acoustic generator **101**.

To be specific, as illustrated in FIG. 4, the electronic device **2** includes an electronic circuit including a control circuit **21**, a signal processing circuit **22**, and a communication circuit **23**; an antenna **24**; and the case **200** accommodating these. Other electric members (for example, devices such as a display and a microphone and circuits) included in the electronic device **2** are not illustrated.

The communication circuit **23** receives a signal input from the antenna **24** and outputs it to the signal processing circuit **22**. The signal processing circuit **22** processes the signal input from the communication circuit **23** to generate a sound signal S, and outputs it to the acoustic generator **101**. The acoustic generator **101** generates sound based on the sound signal S. The control circuit **21** controls the entirety of the electronic device **2** including the signal processing circuit **22** and the communication circuit **23**.

The electronic device **2** having the configuration includes the acoustic generator **101** capable of generating high-quality sound with small frequency-related variation of the sound pressure, thereby generating high-quality sound.

Although FIG. 4 illustrates an example in which the acoustic generator **101** is attached directly to the case **200** of the electronic device **2**, the acoustic generator **101** is not limited to be attached in this manner. For example, the acoustic generation device **70** in which the acoustic generator **101** is attached to the housing **71** as illustrated in FIG. 3 may be attached to the case **200** of the electronic device **2**.

The electronic device **2** on which the acoustic generator **101** is mounted is not limited to conventionally well-known electronic devices that generate sound, such as mobile phones, tablet terminals, televisions, and audio devices. The electronic device **2** on which the acoustic generator **101** is

mounted may be electric products such as refrigerators, microwaves, vacuum cleaners, and washing machines.

Fourth Embodiment

Next, the configuration of an acoustic generator **102** according to a fourth embodiment will be described with reference to FIG. 5A. FIG. 5A is a cross-sectional view schematically illustrating the configuration of the acoustic generator **102** in the embodiment. In FIG. 5A, illustration of the configuration of the piezoelectric vibration element **30** and the adhesive **26** is omitted. In the embodiment, only points different from the acoustic generator **101** in the above-mentioned first embodiment are described, and the same reference numerals denote the same constituent components and overlapped description thereof is omitted.

As illustrated in FIG. 5A, in the acoustic generator **102** in the embodiment, the vibration body **20** is configured by the first portion **201** and a second portion **202a**. The second portion **202a** is locally provided on a part of the lower main surface (at the side opposite to the piezoelectric vibration element **30**) of the first portion **201**. That is to say, in the acoustic generator **102** in the embodiment, one of the first portion **201** and the second portion **202a** is locally provided on the other of the first portion **201** and the second portion **202a**. This configuration can reduce frequency-related variation of sound pressure and can finely adjust a vibration state of the vibration body **20**.

The second portion **202a** is provided on a portion of a composite vibration body configured by the first portion **201** and the piezoelectric vibration element **30** on which stiffness is changed when seen from the above. The portion of the composite vibration body configured by the first portion **201** and the piezoelectric vibration element **30** on which the stiffness changes is a boundary between a portion on which the piezoelectric vibration element **30** is present and a portion on which the piezoelectric vibration element **30** is absent. The second portion **202a** is provided across the boundary, that is, across both the portion on which the piezoelectric vibration element **30** is present and the portion on which the piezoelectric vibration element **30** is absent. Stress is concentrated on the portion on which the stiffness changes. This configuration can improve the sound quality of sound that is generated. In the specification, when the acoustic generator is seen from the above, it is seen from the above along the thickness direction (direction perpendicular to the main surface of the vibration body **20**, Z-axis direction in FIG. 5A) of the vibration body **20** unless otherwise described.

Fifth Embodiment

Next, the configuration of an acoustic generator **103** according to a fifth embodiment will be described with reference to FIG. 5B. FIG. 5B is a cross-sectional view schematically illustrating the configuration of the acoustic generator **103** in the embodiment. In FIG. 5B, illustration of the configuration of the piezoelectric vibration element **30** and the adhesive **26** is omitted. In the embodiment, only points different from the acoustic generator **101** in the above-mentioned first embodiment are described, and the same reference numerals denote the same constituent components and overlapped description thereof is omitted.

As illustrated in FIG. 5B, in the acoustic generator **103** in the embodiment, the vibration body **20** is configured by a first portion **201a** and the second portion **202**. The first portion **201a** is provided on a part of the upper main surface (at the side of the piezoelectric vibration element **30**) of the second

portion **202** and the piezoelectric vibration element **30** is attached onto the first portion **201a**. As in the acoustic generator **101** in the first embodiment and the acoustic generator **102** in the fourth embodiment, the acoustic generator **103** in the embodiment having this configuration can also generate high-quality sound with small frequency-related variation of sound pressure.

Sixth Embodiment

Next, the configuration of an acoustic generator **104** according to a sixth embodiment will be described with reference to FIG. 6. FIG. 6 is a cross-sectional view schematically illustrating the configuration of the acoustic generator **104** in the sixth embodiment. In FIG. 6, illustration of the configuration of the piezoelectric vibration element **30** and the adhesive **26** is omitted. In the embodiment, only points different from the acoustic generator **102** in the above-mentioned fourth embodiment are described, and the same reference numerals denote the same constituent components and overlapped description thereof is omitted.

In the acoustic generator **104** in the sixth embodiment, as illustrated in FIG. 6, the vibration body **20** is configured by the first portion **201** and two second portions (**202b**, **202c**) and the two second portions **202b** and **202c** are provided on the lower main surface (at the side opposite to the piezoelectric vibration element **30**) of the first portion **201** with a predetermined space therebetween in the direction parallel with the main surface. The two second portions **202b** and **202c** have different elastic moduli. For example, when any one of the two second portions **202b** and **202c** is formed by aluminum foil, the other thereof is formed by another metal foil having different elastic modulus desirably. The acoustic generator **104** in the embodiment having this configuration can generate high-quality sound with small frequency-related variation of sound pressure.

Although the two second portions **202b** and **202c** are provided on the other main surface of the first portion **201** in FIG. 6, equal to or more than three second portions can be

Seventh Embodiment

Next, the configuration of an acoustic generator **105** according to a seventh embodiment will be described with reference to FIG. 7. FIG. 7 is a cross-sectional view schematically illustrating the acoustic generator **105** in the seventh embodiment. In FIG. 7, illustration of the configuration of the piezoelectric vibration element **30** and the adhesive **26** is omitted. In the embodiment, only points different from the acoustic generator **102** in the above-mentioned fourth embodiment are described, and the same reference numerals denote the same constituent components and overlapped description thereof is omitted.

In the acoustic generator **105** in the embodiment, as illustrated in FIG. 7, the vibration body **20** is configured by the first portion **201** and two second portions **202d** and **202e**. The first portion **201** and the two second portions **202d** and **202e** are sequentially laminated and the elastic moduli of the respective layers are set to be higher gradually as they are farther from the first portion **201**. To be specific, in the acoustic generator **105** in the embodiment, the two second portions **202d** and **202e** laminated on each other are provided on the lower main surface of the first portion **201**. The elastic modulus of the second portion **202e** as a second layer is set to be higher than that of the second portion **202d** as a first layer that is provided directly on the first portion **201**.

In this case, for example, when the second portion **202d** as the first layer is formed by aluminum foil, the second portion **202e** as the second layer is formed by another metal foil having an elastic modulus higher than that of the aluminum foil. In contrast, when the second portion **202e** as the second layer is formed by aluminum foil, the second portion **202d** as the first layer is formed by another metal foil having an elastic modulus lower than that of the aluminum foil.

The acoustic generator **105** in the embodiment having this configuration can generate higher-quality sound with smaller frequency-related variation of sound pressure. Although the two second portions **202d** and **202e** are provided on the other side surface of the first portion **201** in the example as illustrated in FIG. 7, equal to or more than three second portions may be laminated. Although it is desirable that types of the metal foils of the respective layers be varied and the elastic moduli thereof be set to be higher gradually as they are farther from the first portion **201**, they are not necessarily limited to this configuration. Furthermore, the thicknesses of the metal foils of the respective layers can be also varied appropriately.

Modifications

The invention is not limited to the above-mentioned embodiments and various changes or improvements can be made in a range without departing from a concept of the invention.

For example, although the piezoelectric vibration element **30** is provided on the main surface of the vibration body at the side of the first portion **201** having the relatively low elastic modulus in the above-mentioned embodiments, the piezoelectric vibration element **30** may be provided on the surface thereof at the side of the second portion **202** having the relatively high elastic modulus depending on cases.

Although the examples in which the thickness of the first portion **201** is set to be larger than the thickness of the second portion **202** are indicated in the above-mentioned embodiments, the thickness of the first portion **201** may be smaller than the thickness of the second portion **202**.

Although the examples in which one piezoelectric vibration element **30** is arranged on the vibration body **20** are indicated in the above-mentioned embodiments, a plurality of piezoelectric vibration elements **30** may be arranged on the vibration body **20**. Although the piezoelectric vibration element **30** has the rectangular shape when seen from the above in the above-mentioned embodiments, for example, the piezoelectric vibration element **30** may have another shape such as an elliptical shape.

Although the examples in which the bimorph-type piezoelectric vibration element **30** is employed are indicated in the above-mentioned embodiments, the piezoelectric vibration element **30** is not limited thereto. For example, the same effects can be provided even by using a unimorph-type piezoelectric vibration element configured by bonding a plate made of metal or the like to one main surface of the piezoelectric vibration element that vibrates to expand and contract in the plane direction, instead of the bimorph-type piezoelectric vibration element. Alternatively, the piezoelectric vibration elements that vibrate to expand and contract in the plane direction may be provided on both the surfaces of the vibration body **20**, that is, the unimorph-type or bimorph-type piezoelectric vibration elements may be provided on both the surfaces of the vibration body **20**.

Those skilled in the art can derive additional effects and modifications easily. A wider aspect of the invention is not limited by specific details and representative embodiments that are represented and described as described above.

Accordingly, various changes can be made without departing from the spirit or the scope of the general concept of the invention defined by the accompanying scope of the invention and equivalents thereof.

The invention claimed is:

1. An acoustic generator comprising:

a frame;
a vibration body provided at an inner side of the frame;
a piezoelectric vibration element provided on the vibration body; and
a resin layer provided on the vibration body so as to cover the piezoelectric vibration element, wherein the vibration body has a configuration in which a thin plate-like first portion and a thin plate-like second portion having different elastic moduli are laminated.

2. The acoustic generator according to claim 1, wherein the first portion has a lower elastic modulus than the second portion,

the piezoelectric vibration element is provided on an outer surface of the vibration body, and
the piezoelectric vibration element is provided on the first portion.

3. The acoustic generator according to claim 1, wherein the first portion has a larger thickness than that of the second portion.

4. The acoustic generator according to claim 1, wherein the first portion is made of resin and the second portion is made of metal.

5. The acoustic generator according to claim 1, wherein the first portion is made of porous resin.

6. The acoustic generator according to claim 1, wherein entirety of the vibration body has a configuration in which the first portion and the second portion are laminated.

7. The acoustic generator according to claim 1, wherein one of the first portion and the second portion of the vibration body is locally provided on the other of the first portion and the second portion.

8. The acoustic generator according to claim 7, wherein a composite vibration body is comprised of the piezoelectric vibration element and the other of the first portion and the second portion, and the one of the first portion and the second portion is provided on a portion of the composite vibration body on which stiffness changes when seen from the above.

9. The acoustic generator according to claim 1, wherein at least a part of a surface of the vibration body at a side at which the piezoelectric vibration element is arranged is further covered by a cover layer.

10. The acoustic generator according to claim 1, wherein the vibration body and the piezoelectric vibration element are bonded to each other with an adhesive.

11. An acoustic generation device comprising at least:

a housing; and
the acoustic generator according to claim 1 that is provided on the housing.

12. An electronic device comprising at least:

a case;
the acoustic generator according to claim 1 that is provided on the case; and
an electronic circuit connected to the acoustic generator, wherein the electronic device has a function of generating sound from the acoustic generator.

13. An acoustic generator comprising:

a frame;
a vibration body provided inside of the frame;

13

a piezoelectric vibration element provided on the vibration body; and
a resin layer provided on the vibration body so as to cover the piezoelectric vibration element, wherein the vibration body has a configuration in which a first portion and a second portion are laminated, and the first portion and the second portion each have different elastic moduli.

14. The acoustic generator according to claim **13**, wherein each of the first portion and the second portion has a shape like a thin plate.

15. The acoustic generator according to claim **1**, wherein the first portion has a lower elastic modulus than the second portion, the piezoelectric vibration element is provided on an outer surface of the vibration body, and the piezoelectric vibration element is provided on the first portion.

16. The acoustic generator according to claim **13**, wherein the first portion has a larger thickness than the second portion.

17. The acoustic generator according to claim **13**, wherein entirety of the vibration body has a configuration in which the first portion and the second portion are laminated.

14

18. The acoustic generator according to claim **13**, wherein one of the first portion and the second portion of the vibration body is locally provided on the other of the first portion and the second portion,

a composite vibration body is comprised of the piezoelectric vibration element and the other of the first portion and the second portion, and

the one of the first portion and the second portion is provided on a portion of the composite vibration body on which stiffness changes when viewed in a plan view.

19. An acoustic generation device comprising:
a housing; and
the acoustic generator according to claim **13** that is provided on the housing.

20. An electronic device comprising:
a case;
the acoustic generator according to claim **13** that is provided on the case; and
an electronic circuit connected to the acoustic generator.

* * * * *