

(19)
(12)

(KR)
(B1)

(51) 。 Int. Cl.7
G06F 3/03

(45)
(11)
(24)

2004 03 26
10-0399563
2003 09 16

(21) 10-1995-0033684
(22) 1995 10 02

(65)
(43)

10-1996-0015343
1996 05 22

(30) 08/317952 1994 10 04 (US)

(73) 136-1

95134 3101

(72) 80917 2765

(74)

:

(54)

가 . 0 n-1 가 (, n).
가 가 , , .

1

, , , , , , , ,

1
2

3
4
*
10:
12:
16:

11:
13:

(digitizing tablet)

(shielding)

가

가

4,644,102

(copper strips)

(matched filter)

(dem

odulator)

4,636,582

(stylus)

(handw

ritten)

4,497,977

(handheld)

3,974,332

(apertures)

(crosstalk)

3,732,369

x, y

x, y

4,956,526

4,853,497

(nonferrous)

(digitizer)

5,124,509

(submultip

le)

5,218,173

(electromagnetic)

) 가

, (,

2 , 가 (21, 23) (12) (10) 가 (12)
 . 가 (27) (25) . , (12)
 가 (27) (18a) (18b) (16) 가 ,
 (27) (29) . 가 (23) (16) 가 ,
 (16) (16) . (.)
 , (29) , ,
 가 3 . (12) 가 (21, 23) 가 (25) 2
 31) (33) . (12), , (25) (가) ()
 (18a) (18b) . (33) , 2 ,
 (16) (12)가 - (quasi-floating) , 가
 (12) , (41) , 3 . (1)
 2) (12) 4 , 가 (43) (47) (47)
 (47) (45) () ,
 (45) (47) (common mode rejection)
 (401, 403) . (401, 403) (16) .

(57)

1.

(stylus)

1 2 가 , 1 2
 ; ;
 ; ; 1
 ; ;
 가 , - ;
 2 ,

2.

1

3.

가 ,
 - ;
 1 2 가 , 1 ; 2
 , 2 2 - ; 1 1 -
 2 2

4.
 3 , n 가 , 0 n-1 가

5.
 3 , 2

6.
 5 ,
 7. (common mode rejection stage)

- , -

1 2 가 , 1 ; 2
 , 2 , 1

8.
 7 , 가 (conductive coating)

9.
 7 , - -

10.
 7 , 2

11.
 - ; ,

1 2 가 , 1 ; 2
 2 , 1 ,

12.
 11 ,

13.
 11 ,

1

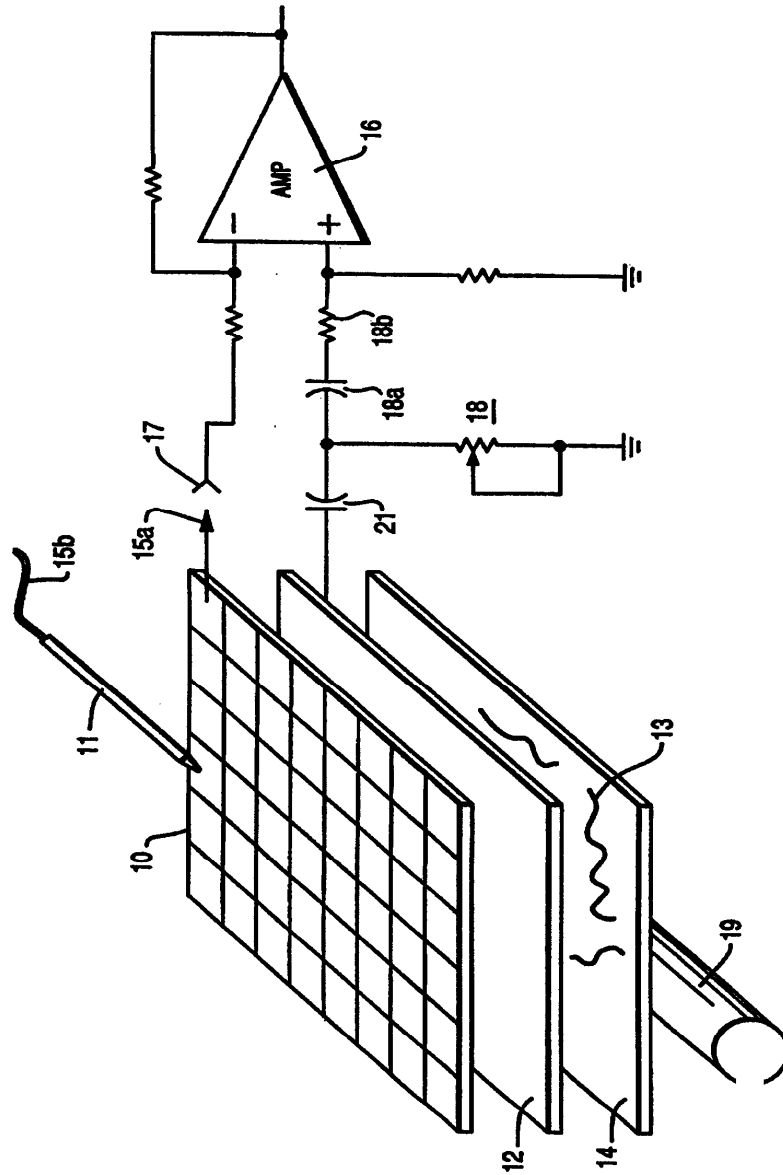

2

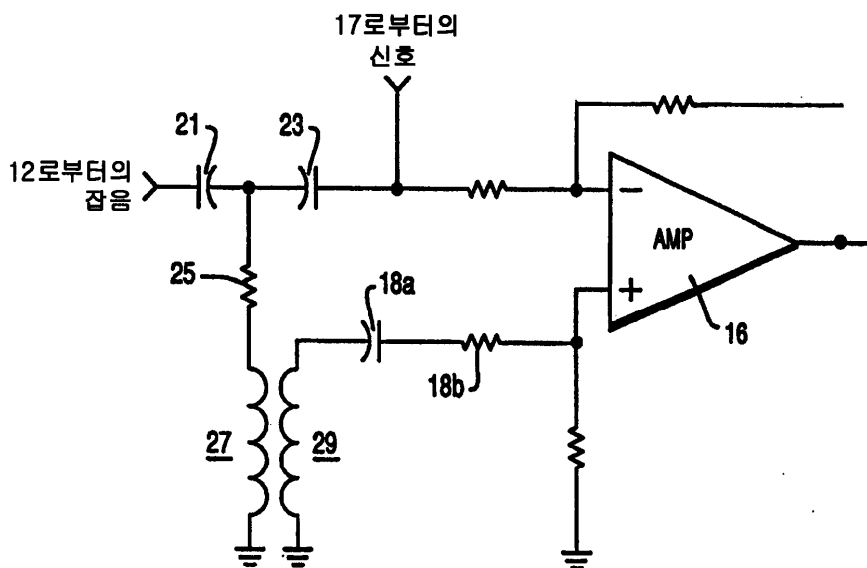

3

