

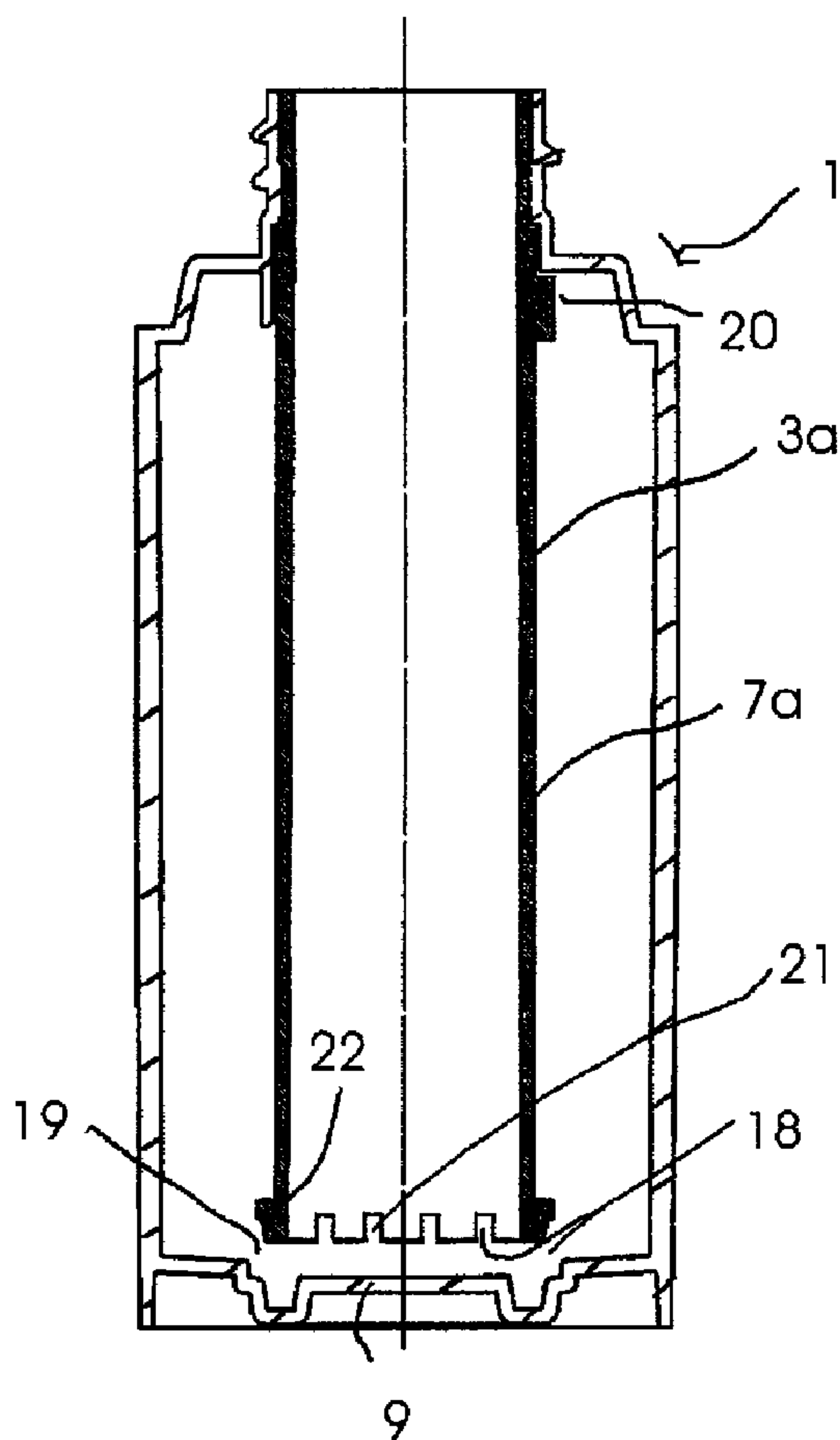

(22) Date de dépôt/Filing Date: 2008/05/29
 (41) Mise à la disp. pub./Open to Public Insp.: 2008/11/30
 (45) Date de délivrance/Issue Date: 2011/04/26
 (30) Priorité/Priority: 2007/05/31 (EP07 010 826.1)

(51) Cl.Int./Int.Cl. *B01L 3/00* (2006.01),
B65D 23/00 (2006.01), *B65D 51/24* (2006.01),
G01N 35/00 (2006.01)
 (72) Inventeurs/Inventors:
 SENFTER, GOTTFRIED, DE;
 WINKENBACH, MARKUS, DE
 (73) Propriétaire/Owner:
 F. HOFFMANN-LA ROCHE AG, CH
 (74) Agent: BORDEN LADNER GERVAIS LLP

(54) Titre : RECIPIENT AVEC CHEMINEE A EXTRACTION VARIABLE
 (54) Title: LIQUID CONTAINER WITH VARIABLE EXTRACTION CHIMNEY



(57) Abrégé/Abstract:

The invention proposes a liquid container having a top opening and having a tube-like extraction chimney which extends into the container in alignment with the opening and is intended for the withdrawal of liquid by means of a liquid-withdrawal element which

(57) **Abrégé(suite)/Abstract(continued):**

can be introduced into the extraction chimney, the extraction chimney having a liquid-permeable zone in its bottom end region, which is adjacent to the container base. In respect of the liquid permeability of the liquid-permeable zone, the extraction chimney can be adjusted between a defined limit setting for minimal liquid permeability and a defined setting for greater liquid permeability, while remaining in the container.

ABSTRACT

The invention proposes a liquid container having a top opening and having a tube-like extraction chimney which extends into the container in alignment with the opening and is intended for the withdrawal of liquid by means of a liquid-withdrawal element which can be introduced into the extraction chimney, the extraction chimney having a liquid-permeable zone in its bottom end region, which is adjacent to the container base. In respect of the liquid permeability of the liquid-permeable zone, the extraction chimney can be adjusted between a defined limit setting for minimal liquid permeability and a defined setting for greater liquid permeability, while remaining in the container.

Liquid container with variable extraction chimney**Description**

5 The invention relates to a liquid container having a top opening and having a tube-like extraction chimney which extends into the container in alignment with the top opening and is intended for the extraction of liquid by means of an extraction element, in particular
10 a pipette, which can be introduced into the extraction chimney from above, the extraction chimney having a liquid-permeable zone in its bottom end region, which is adjacent to the container base.

15 The invention concerns, in particular, liquid containers which are used as reagent liquid vessels in automatic analysers. When used in such an automatic analyser, the liquid containers have reagent liquid extracted from them by automatic pipetting. This takes
20 place, in more modern systems, at high speeds, in order to allow a high throughput of relevant analysis operations. The liquid containers here are supplied quickly to the pipetting station by a transporting means, e.g. in the form of a rotor, and are braked
25 there, whereupon the automatic pipette or suction needle penetrates through the top opening of the liquid container into the extraction chimney in order to extract liquid by suction. In the case of automatic analysers for a high throughput, only extremely short
30 cycle times of a few seconds are available for each individual pipetting operation, including the positioning of the liquid container in the pipetting zone. This gives rise to the problem where, when the liquid container is stopped abruptly in the pipetting
35 zone, the liquid sloshes in the container, and possibly sprays upwards, in which case any kind of evened out liquid level is often established only after a respective waiting period, which lasts longer than the short pipetting cycle time which is required for high

throughput operation. Pipetting in the presence of a liquid level which is still fluctuating to a pronounced extent in the extraction chimney is usually to be avoided since the pipette tip here is undesirably wetted with the liquid on its outside, over a relatively large region, and thus a comparatively large volume of entrained liquid remains on the outside of the pipette tip as the pipette is drawn back out of the liquid container, and this then gives rise to contamination in the case of further pipetting operations. In order to avoid this, the pipette tip, during pipetting, should only penetrate to a slight extent into the liquid which is to be pipetted, and the filling level in the liquid container should be, as far as possible, at rest. The situation where the pipette entrains air on account of a fluctuating liquid level should also be avoided. Furthermore, the formation of foam in the extraction chimney should be prevented.

In respect of the prior art relating to reaction liquid containers with an extraction chimney, reference may be made, for example, to WO 97/12677 A1, to US 5,102,631 or to DE 38 38 278 C1. In the case of the liquid container from WO 97/12677 A1, the tubular extraction chimney is provided, at its top end, with a radially outwardly projecting flange, by way of which it is supported in a hanging state on a nozzle of the container opening. The completely open bottom end of the extraction chimney here extends into the vicinity of the base of the liquid container, in which case, by way of the bottom opening of the extraction chimney, liquid communication between the extraction chimney and the interior region of the liquid container which encloses it can take place only via a narrow base gap. In order that pressure equalization can take place between the interior of the container and the surroundings during pipetting, slot-like wall-thickness reductions are provided in the top region of the extraction chimney, and these are intended to allow air

- 3 -

to flow in between the opening nozzle of the liquid container and the lateral surface of the extraction chimney.

5 DE 38 38 278 C1 discloses a liquid container having an extraction chimney in the case of which the cross section of the extraction chimney is significantly smaller than the cross section of the top container opening, this extraction chimney passing through a
10 screw top, which is screwed to the opening nozzle, and being fixed to the same. A through-hole in the screw top allows pressure equalization between the container interior and the external surroundings. The extraction chimney extends into the vicinity of the container
15 base, in which case, the exchange of liquid between the extraction chimney and the container interior which encloses it can take place by way of the open underside of the extraction chimney. In the case of a further exemplary embodiment of DE 38 38 278 C1, the outer
20 circumference of the extraction chimney at the top end of the latter and the inner circumference of the nozzle which encloses the extraction chimney at its top end are only slightly different, in which case there is no ventilation path of sufficient magnitude for pressure
25 equalization between the container interior and the surroundings remaining between the outside of the extraction chimney and the inner surface of the nozzle. For pressure-equalization purposes, a through-bore is provided in the lateral surface of the extraction
30 chimney, at the top end of the latter. The extraction chimney is essentially completely open at its bottom end, spacing webs being provided at the bottom end of the extraction chimney.

35 The liquid container which is known from US 5,102,631 is of similar construction to the last-mentioned exemplary embodiment from DE 38 38 278 C1 and thus likewise has a through-hole in the lateral surface of the extraction chimney, at the top end of the latter.

The extraction chimney extends to the base of the liquid container, although large lateral openings are provided in the lateral surface of the extraction chimney, at the bottom end of the latter.

5

In accordance with the functional principle of the extraction chimney, it is provided in the case of the known examples that there is only a small spacing, and thus only a narrow flow gap for forming a high flow
10 resistance, between the bottom end of the extraction chimney and the container base located opposite, in which case fluctuations in the container volume outside the extraction chimney can act within the extraction chimney at best only in a damped state. The known
15 extraction chimneys thus have, in their end region adjacent to the container base, a liquid-permeable zone with a low level of liquid permeability.

However, this restriction of the liquid permeability,
20 which is necessary for the desired functioning of the extraction chimney, is also associated with the disadvantages, namely in the case of such liquid containers of the type in question here which are to be filled with liquid in the first instance through the
25 extraction chimney from the top opening. Filling has to take place very slowly since, on account of the low level of liquid permeability of the liquid-permeable zone, the filling level in the extraction chimney rises very much more quickly than the filling level in the
30 container region outside the extraction chimney. Overly quick filling may result in the liquid overflowing at the top opening of the container.

Even conventional liquid containers in which the
35 extraction chimney is to be inserted only after the liquid has been introduced have posed the problem that an overflow of liquid through the top container opening can only be avoided if the extraction chimney is introduced comparatively slowly into the container

- 5 -

since, on account of the low level of liquid permeability of the liquid-permeable zone, the liquid cannot rise up quickly enough into the chimney at the bottom end of the latter.

In one aspect of the invention, there is provided, a liquid container of the type mentioned in the introduction which can be filled, if required, quickly through the top opening and through the extraction chimney and nevertheless, during liquid-extraction operation, has the desired properties in respect of the liquid level within the extraction chimney settling in relation to the fluctuations in the container region. outside the extraction chimney.

In order to achieve this, taking a liquid container of the type mentioned in the introduction as the departure point, the invention proposes that, in respect of the liquid permeability of the liquid-permeable zone, the extraction chimney can be adjusted between a defined limit setting for minimal liquid permeability and a defined setting for greater liquid permeability, while remaining in the container.,

For filling operation of the liquid container, the extraction chimney, and thus the liquid-permeable zone, can be set, for example, such that its liquid permeability is at a relatively high level. Following the filling operation, the liquid-permeable zone can then be returned to a state of low liquid permeability, in which case the extraction chimney can perform its desired function during liquid-extraction operation of the liquid container. In particular, the liquid permeability of the liquid-permeable zone is not fully suppressed in any of the settings of the extraction chimney. In the position for minimal liquid permeability, the exchange of liquid can thus take place between the extraction chimney and the container body which encloses it.

- The liquid-permeable zone preferably comprises at least one opening in the bottom end region of the extraction chimney with an effective opening cross section which can be adjusted, it preferably being possible for this to take place by a rotary movement and/or lifting movement of the extraction chimney, or of a part of the same, relative to the liquid-container base.
- 10 Stop means and/or latching means and/or markings are preferably provided on the extraction chimney and/or on the container body in order to define the limit settings for minimal liquid permeability and greater liquid permeability of the liquid-permeable zone.
- 15 According to a preferred embodiment of the invention, the extraction chimney has a tube portion extending downwards from the top container opening as well as a tube holder for the tube portion, this tube holder
- 20 being provided on the container base, it being possible for the tube portion and the tube holder to be plugged one inside the other, and adjusted relative to one another, in order to change the effective opening cross section of the liquid-permeable zone. In the case of
- 25 such an embodiment of the invention, the liquid-permeable zone incorporates lateral openings in the tube portion and lateral openings in the tube holder in the bottom end region of the extraction chimney, it being possible for lateral openings of the tube portion
- 30 and lateral openings of the tube holder to be aligned relative to one another in order to increase the effective opening cross section of the liquid-permeable zone.
- 35 In another version of the invention, the permeability of the liquid-permeable zone is changed simply by a tube portion of the extraction chimney, this tube portion extending from the top container opening into the vicinity of the container base, being moved up

- 7 -

closer to the container base, in which case, only a small throughflow gap remains between the container base and the bottom end of the tube portion. This is then the state for the lower level of liquid permeability of the liquid-permeable zone. By virtue of the tube portion being raised, and of the associated increase in the spacing between the bottom end of the tube portion and the container base, the liquid permeability of the liquid-permeable zone is then increased.

The extraction chimney is preferably secured in the liquid container, in which case, even when the liquid container is open, it cannot be removed from the latter under normal handling conditions.

In one aspect, there is provided a liquid container having: a top opening, and a tube-like extraction chimney which extends into the liquid container in alignment with the top opening for withdrawal of liquid by means of a liquid-withdrawal element for introduction into the extraction chimney, the extraction chimney having a bottom end region comprising a liquid-permeable zone which is adjacent to a base of the container, and at least one opening in the bottom end region with an effective opening cross section, wherein, to change the liquid permeability of the liquid-permeable zone by changing the effective opening cross section, the extraction chimney is adjustable between a defined limit setting for minimal liquid permeability and a defined setting for greater liquid permeability, while remaining in the container, and wherein the effective opening cross section of the liquid-permeable zone is settable by a rotary movement or a lifting movement of the

- 7a -

5 extraction chimney, or a part thereof, relative to the base, between at least two defined stop positions or latching positions which are assigned to different effective opening cross sections.

The invention also relates to a method of preparing a liquid container for providing a liquid in an automatic analyser, comprising the following steps:

- 10 - providing the liquid container in an automatic filling station,
- ensuring that, for a following introduction step, the extraction chimney in the liquid container has been set to the position for a relatively high level of liquid permeability of the liquid-
- 15 permeable zone,
- introducing the liquid through the extraction chimney into the liquid container with the extraction chimney set to the position for a relatively high level of liquid permeability of the liquid-
- 20 permeable zone,
- closing the liquid container,
- setting the extraction chimney to the position for minimal liquid permeability of the liquid-
- 25 permeable zone as a preparation step for the extraction of liquid from the container.

Setting the extraction chimney to the position for greater liquid permeability can take place prior to the

30

35

- 8 -

liquid container being introduced into the automatic filling station or thereafter. The critical factor is for the normally automatic and rapidly carried out introduction step to take place with the extraction chimney set to the position for greater liquid permeability of the liquid-permeable zone.

Setting the extraction chimney to the position for minimal liquid permeability takes place following the filling operation, it being possible for this preparation step for the extraction of liquid from the contain to take place prior to the liquid container being closed or thereafter and, if appropriate, at a different location, for example in an automatic analyser.

A particularly advantageous use of the liquid container according to the invention is thus proposed in which the liquid can be introduced in a high-speed automatic filling station, during high throughput operation, in order to prepare the liquid container for subsequently providing the liquid in a high-speed automatic analyser, the extraction of liquid in the automatic analyser taking place by virtue of liquid being extracted from the liquid container by suction using a pipette or the like, with the extraction chimney set to the position for minimal liquid permeability of the liquid-permeable zone. High throughput operation in the automatic filling station and high throughput operation in the automatic analyser are thus possible using the liquid container according to the invention without it being necessary to accept disadvantages over the prior art in respect of the liquid containers of the generic type.

Exemplary embodiments of the invention are explained in more detail hereinbelow with reference to the figures, in which

- 9 -

5 Figures 1a and 1b show a sectional illustration of a first exemplary embodiment of a liquid container according to the invention having an extraction chimney with two different limit settings for the opening cross section of the liquid-permeable zone of the extraction chimney,

10 Figures 2a and 2b show a second exemplary embodiment of a liquid container according to the invention having an extraction chimney with two different limit settings for the liquid permeability of the liquid-permeable zone of the extraction chimney, and

15 Figures 3a and 3b show a variant of the second exemplary embodiment.

20 In the figures, the vertical longitudinal section runs centrally through the extraction chimney 3 or 3a.

25 The liquid container 1 is a reagent liquid vessel which is used in automatic analysers in the manner which has been described in the introduction.

30 The liquid container 1 has, at its top end, a screw-closure opening 5, from which a tube portion 7 of the extraction chimney 3 extends vertically into the container interior. The container base 9 has a tube holder 11 which is of cup-like form with two, for example, rectangular cutouts 13 which are open towards the top. As seen in the viewing direction of Figures 1a and 1b, the cutouts 13 are aligned one behind the other on diametrically opposite sides of the tube holders 11.

35 The tube portion 7 has its bottom end accommodated in the tube holder 11, to be precise such that its outer

- 10 -

circumference is closely adjacent to the inner circumference of the tube holder 11 and is preferably located opposite the same, in contact therewith. The tube holder 11 thus forms a rotary bearing for the tube portion 7 of the extraction chimney 3, in which case the tube portion 7 can be rotated about the vertical axis of rotation 15 between two defined rotary stop positions. It is possible here for lateral cutouts 17, which are provided on diametrically opposite regions of the tube portion 7 and do not extend upwards beyond the uppermost periphery of the tube holder 11, to be rotated relative to the cutouts 13 of the tube holder. The cutouts 17 and 13 constitute lateral openings in the tube portion 7 and in the tube holder and, together, form a liquid-permeable zone 18 of the extraction chimney 3, the effective opening cross section of this zone depending on the extent to which the lateral openings 17 of the tube portion 7 are aligned with the lateral openings 13 of the tube holder 11. In Figure 1a, the lateral openings 17 of the tube portion 7 are fully aligned with the lateral openings 13, in which case the openings 13, 17 exhibit a maximum overlap. This is the limit position for the maximum effective opening cross section of the liquid-permeable zone 18 of the extraction chimney 3, i.e. the defined setting for the relatively high level of liquid permeability of the liquid-permeable zone. It is possible in this situation for relatively good exchange of liquid to take place between the interior of the extraction chimney and the container volume outside the extraction chimney 3, which is important for the operation of filling the liquid container 1 through the opening 5 and the extraction chimney 3.

For subsequent liquid-extraction operation, in the case of which liquid is to be extracted by suction from the extraction chimney 3 from above using a pipette or suction needle, good liquid communication between the interior of the extraction chimney and the container

- 11 -

volume outside the extraction chimney is very disadvantageous since fluctuations of the liquid in the container volume outside the extraction chimney 3 are quickly transferred, with only low-level damping, to the interior of the extraction chimney 3. This problem is solved by the liquid container according to Figures 1a and 1b in that, by virtue of the tube portion 7 being rotated relative to the tube holder 11 of the extraction chimney 3, the common effective opening cross section of the lateral openings 13 and 17 of the tube portion 7 and of the tube holder 11 can be set to a smaller value, as illustrated in Figure 1b. Figure 1b shows the extraction chimney 3 in the limit position for minimal liquid permeability of the zone 18, with a small effective opening cross section of the liquid-permeable zone 18, as should be selected for liquid-extraction operation. Rotary stops which prevent the tube portion 7 from being rotated beyond the limit settings shown are not shown in Figures 1a and 1b.

20

It should be noted that the figures do not depict ventilation channels or spacing indents between the inner surface 6 of the screw-closure nozzle and the outer circumference of the tube portion 7 or ventilation openings in the top region of the tube portion 7, which ensure pressure equalization between the external surroundings and the container interior, since they do not form part of the main aspect of the present invention. However, such ventilation measures should be taken in practice. Use can be made, for this purpose, of the wide variety of different proposals from the prior art. This also applies to the second exemplary embodiment according to Figures 2a and 2b.

35

In the case of the illustration of the second exemplary embodiment in Figures 2a and 2b, identical designations have been used for elements which essentially correspond, in terms of functioning, to the elements in Figures 1a and 1b. For an understanding of the second

- 12 -

exemplary embodiment, it is thus possible, in this respect, to refer to the explanations given for the first exemplary embodiment according to Figures 1a and 1b. The following explanations may thus be restricted to the differences of the second exemplary embodiment in relation to the first exemplary embodiment.

In the case of the second exemplary embodiment, the liquid permeability of the liquid-permeable zone 18 is varied by a lifting movement of the tube portion 7a relative to the vessel base 9. The liquid-permeable zone is defined by the annular gap 19, which is larger when the extraction-chimney tube portion 7a is raised according to Figure 2a than when it is lowered according to Figure 2b, and by the crenellation interspaces 21. Stop means 20 and 22 ensure that defined end positions are possible for the lifting adjustment of the tube portion 7a, as can be seen in Figures 2a and 2b. Figure 2a shows a limit setting of the extraction chimney 3a, which is provided for the operation of filling the container 1. Figure 2b shows that limit setting of the extraction chimney 3a which is advantageous for liquid-extraction operation. Even in the setting for minimal liquid permeability of the liquid-permeable zone according to Figure 2b, exchange of liquid can take place through the zone 18.

A variant of the second exemplary embodiment with a modification of the bottom end of the tube portion 7a is shown in Figures 3a and 3b.

In the case of the embodiment according to Figures 3a and 3b, the tube portion 7a has, at its bottom end, four spacing webs 22 which ensure that, in the lowered state of the tube portion 7a according to Figure 3b, the tube portion does not have its bottom periphery resting with closing action on the base 9, and also a collar 24 running around the tube-portion circumference maintains a spacing from the vessel base 9, in which

- 13 -

case liquid communication between the interior of the extraction chimney 3a and the container volume outside the extraction chimney can take place through the liquid-permeable zone 18 in Figure 3b with reduced liquid permeability. Figure 3a shows a setting of the extraction chimney 3a which is provided for the operation of filling the container 1. Figure 3b shows that position of the extraction chimney 3a which is advantageous for liquid-extraction operation.

10

Numerous modifications of the exemplary embodiments described are conceivable. Thus, for example, the extraction chimney can be adjusted, for example, by a combined lifting and rotary movement. This may be, in particular, a screwing-action movement of the extraction chimney.

15

The extraction chimney can be fitted in the liquid container in particular even before the latter is filled.

20

CLAIMS:

1. A liquid container having:

a top opening, and

a tube-like extraction chimney which extends into the liquid container in alignment with the top opening for withdrawal of liquid by means of a liquid-withdrawal element for introduction into the extraction chimney, the extraction chimney having a bottom end region comprising a liquid-permeable zone which is adjacent to a base of the container, and at least one opening in the bottom end region with an effective opening cross section,

wherein, to change the liquid permeability of the liquid-permeable zone by changing the effective opening cross section, the extraction chimney is adjustable between a defined limit setting for minimal liquid permeability and a defined setting for greater liquid permeability, while remaining in the container, and wherein the effective opening cross section of the liquid-permeable zone is settable by a rotary movement or a lifting movement of the extraction chimney, or a part thereof, relative to the base, between at least two defined stop positions or latching positions which are assigned to different effective opening cross sections.

2. The liquid container according to claim 1, wherein the extraction chimney has a tube portion extending downwards from the top opening, a tube holder for the tube portion being provided on the base, the tube portion and the tube holder being pluggable one inside the other and adjustable relative to one another for changing the effective opening cross section of the liquid-permeable zone.

3. The liquid container according to claim 2, wherein the liquid-permeable zone incorporates lateral openings in the tube portion and lateral openings in the tube holder in the bottom end region of the extraction chimney, and the lateral openings of the tube portion and the lateral openings of the tube holder are alignable relative to one another for increasing the effective opening cross section of the liquid-permeable zone.

4. The liquid container according to any one of claims 1 to 3, wherein the extraction chimney is secured in the liquid container and cannot be drawn out of the container under normal handling conditions, even when the liquid container is open.

5. A method of preparing a liquid container according to any one of claims 1 to 4 for providing a liquid in an automatic analyser, comprising the following steps:

providing the liquid container in an automatic filling station;

ensuring that, prior to introducing the liquid, the extraction chimney in the liquid container has been set to a position for a relatively high level of liquid permeability of the liquid permeable zone;

introducing the liquid through the extraction chimney into the liquid container with the extraction chimney set to the position for a relatively high level of liquid permeability of the liquid-permeable zone;

closing the liquid container; and

setting the extraction chimney to a position of minimal liquid permeability of the liquid-permeable zone in preparation for extraction of the liquid from the container.

1/3

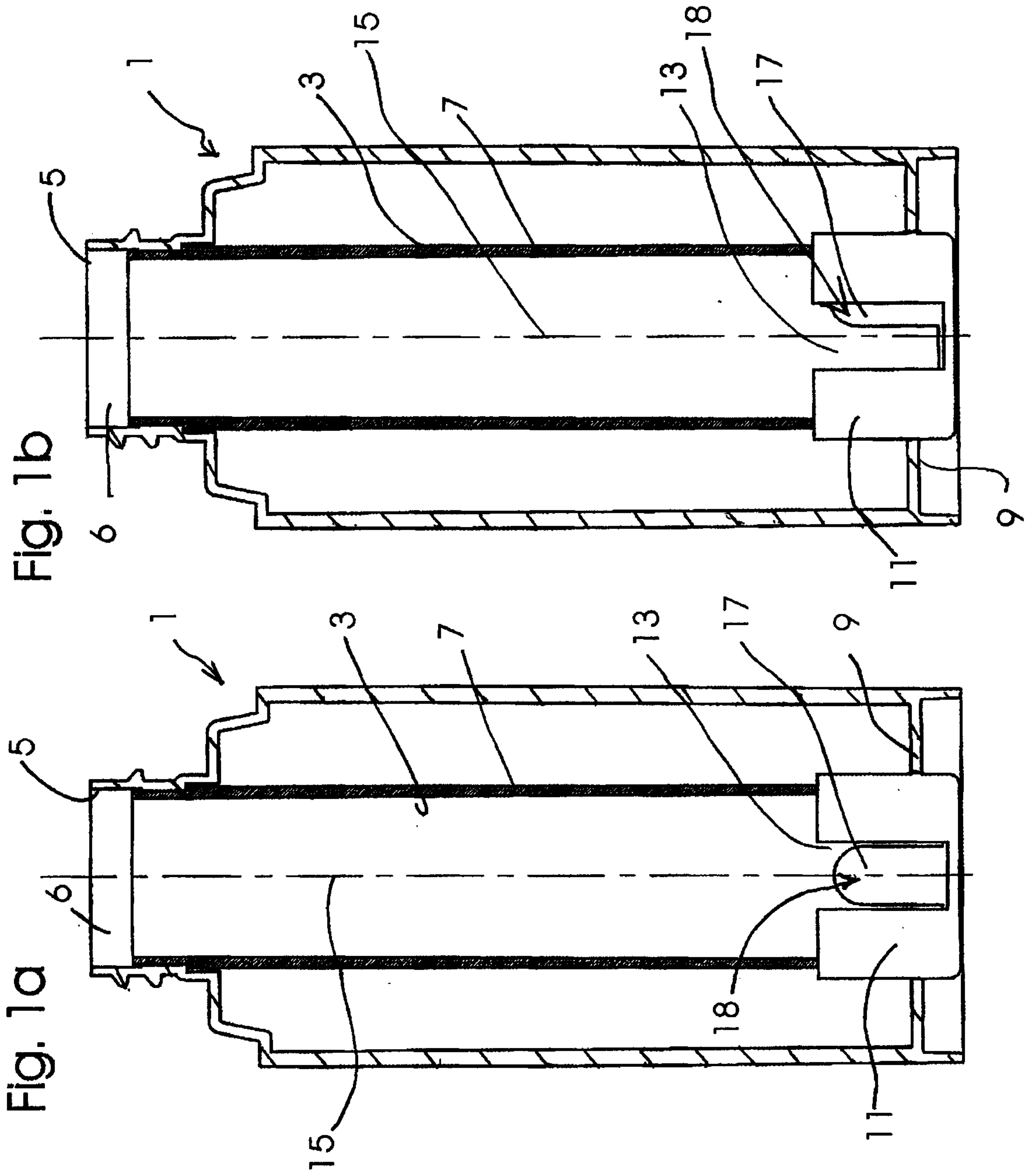

Fig. 1b

Fig. 1a

Fig. 2a

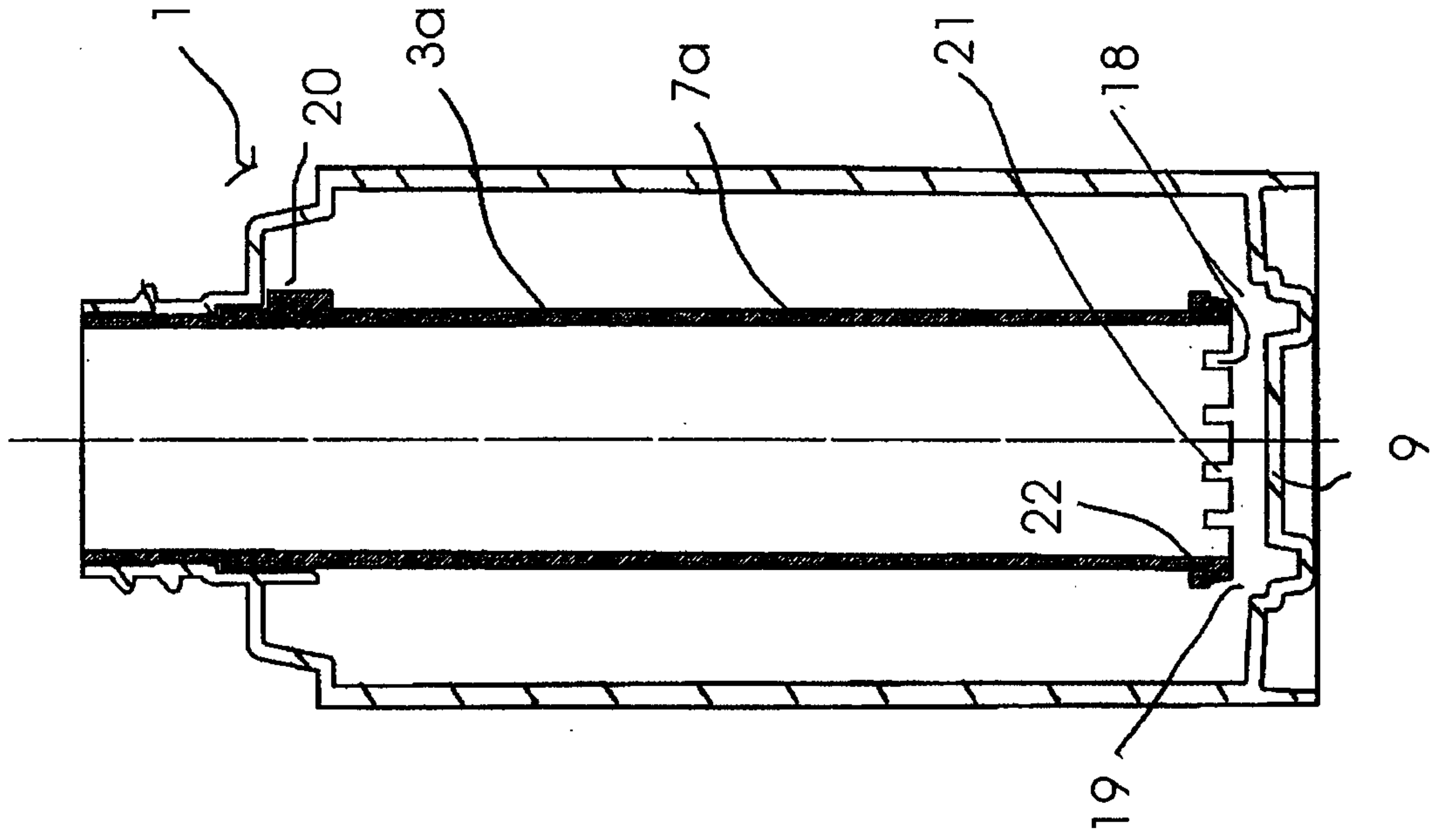

Fig. 2b

