

(19)
(12)

(KR)
(B1)

(51) 。 Int. Cl.7
H01L 27/108

(45)
(11)
(24)

2004 04 28
10-0428595
2004 04 12

(21) 10-2001-0037087
(22) 2001 06 27

(65)
(43)

10-2002-0000845
2002 01 05

(30) 2000-194742 2000 06 28 (JP)

(73) 가 가 1 1 1

(72) 가 가 3-12-1 1101

(74)

:

(54)

가 1 2 , 2 1 2 , 2 1 2 , 1 1 1 1 2 , 2 가 , 2 , 2

3

, , , , ,

1a 1c MOS
2a 2c

가
 < 3a > 3c 1 MOS
 3a A3 A4 (30)
 STI(Shallow Trench Isolation) (31)
 MOS (32a) (30)
 가 (33a) (32a) CVD (Chemical Vapor Depo
 sition) (33a) n, p MOS
 (50-1) (33a) (50-1) (33a)
 3b A4 10^{13} cm^{-3} 10^{15} cm^{-3}
 가 (33a) A4 (32a) (32b)
 (50-1) 가 (33b) (33a)
 CVD (33a) (33b) MOS 3c (33)
 3c (33) (30),
 MOS (33) (30) 가
 (32b) A4 A3 MOS
 (32a) (32b)
 , MOS , 가 ,
 MOS MOS
 2 4a 4c MOS 4a 4c
 4a (31) A3 A4 p (30)
 가 (33a) MOS (32a) (30)
 (33) (33a) (33b) (32a)
 가 (33) A4 (33) (33b)
 (50-2) (50-2)
 4b n (33) (30) (33) 가 (33) (33)
 b) (33a) (32a) (30) (33) A4 (33)
) (30) n (51) (30) A4
 (51) (33) 가 (51a, 51b) (51a) (33)
 (33) (51b) (33)

(4c) (30) MOS (30) (52) .
 , A4 (51a) (53) (52) (52) .
 , (53) (54) (52) (51b) 가
 MOS (32b) (33) .
 (30) (30) (51) .
 , 가 1 , , ,
 , 3 , 5a 5c MOS , 5a 5c 5b 5
 a . 5a 5a 5c .
 , 2 4a .
 n . (33) (50-3) (33) (50-3) 가
 (32a) p (30) (33) , 5b (33) (33)
 (30) (32a) (33) (32b) , (33)
 5c (51) (53) (53) (52) (30) ,
 (54) (53) (53) (53) (53)
 MOS (32b) (33) (51) 가
 (30) (30) , (33) (33)
 51) (33) (33) (33) (33)
 , 가 2 , (33)
 , 가 (33) 가 ,
 , (33) , 2 ,
 가 , 4 , 6a 6b , 6a
 6b . 6a 6b MOS , 6a 6b , 6a
 , 1 , 3a , (50-4) (50-4)
 . 6a (30) (32a) (30) 가 ,
 (33a) (32b) (30)
 (51) (51) (33a) 가 (33b)
 (50-4) , 6b (33a) (33b)
 , (33) 가 (33a) (33b)
 (30) MOS (33) (30) (52)
 (53) (54) (51) (53) (52) (52)

MOS (32b) (33) (51) 가

가 1, 2

가 가

가

5 가

7a 7d 7a 7d

DRAM

7a A4 (31) (30) (30) (32) A3

(33) A3 (32) (30) (34) (34)

A4 (35) (30) (35)

BPSG(Boron Phosphorous Silicate Glass) TEOS(tetraethylorthosili

cate ; Si(OC₂H₅)₄) (37) (35) (36) (35)

7b (35, 36) A4 (34)

(38) (38) (39) (41) (4)

0a), (39) (36) (40a) (41)

A3 A4 (50-5) (36) (50-5)

7c A4 (50-5) (41) (40a) (40b)

가 (40a) (40a) (40a)

(40a)

(50-5) (42) (36) (41) (43)

(44) (42) (42) (45)

7d DRAM DRAM 8a 8b 8a

8b DRAM 7d (60), (61), (62)

DRAM (63) (64)가 (60) (62)

(60) (61) (60) (63) (60) (60)

8b (64) (64) (64) (64)

(70) (71) (71) (71) (60)

(72) 7d (72) (73) (73) (72) (72)

가 가

(73) DRAM (39) (41)

가 (40b) DRAM 가

가

가

, DRAM

DRAM

1 5

(MOS)

가

DRAM

2 4

1 5

(32a)
(30)
(32b)

5

1 4

(32a)

, DRAM

MOS

9a 9c

1 3

9a 9b 9c

9a

(33a)
(52)
(54)

(33b)

(32a)
(52)
(33)

(30)
(54a)
(54)

(54b)

(33)
(33b)
(52)
(52)

9b
2a)
(55)

(33),
(56)

(33)

(55)

(33)
(55)
(55)

(30)

(3)

9c
(57, 57)

(52)

(52)

(57, 57)

가

2

(52)

2
(57, 57)

(57,

57)

가

가

가

(57)

1.

2.

1 MOS ; 1 , 1 1
 2 가 2 , 2 1 , 1
 , 2 2 가 ,

3.

2 ,
 2 2 ,
 2 2 ,

4.

3 , , 2

5.

6.

1 , ; ; ,

7.

1 , 1, 2 ; ;
 ; , 1 2 ;
 ; 1, 2 , , 1, 2 MOS
 , , 2 , 2 2
 1 , 2 , 2 2

8.

9.

1 , 1, 2 ;

2
 ;
 1, 2, 2, 1, 2 MOS ;

2, 2, 2
 1, 2

10.
 9
 2, 2, 2, 1, 2 ;

11.
 10
 1, 2, 2

12.
 1
 1, 2 ;
 2, 2, 2, 1

13.
 12
 1, 2, 2, 1, 2 MOS ;

14.
 13
 1, 2, 2, 1, 2 ;

15.
 12
 1, 2, 2, 1, 2 MOS ;

16.

15 , 2
1 , 1, 2 2 2
, 1, 2 ;

17.

1, 2 ;
1 ; 1 MOS
, 2 ; 1 , 2
1 1 , 2
, , , , .

18.

17 , 1 2

19.

3 , 2

20.

1 MOS ; 1 1 1
2 가 , 2 2 2 2
; , 2 ,
2 , 2 2 2

21.

20 , 2

22.

20 , 2

(종래 기술)

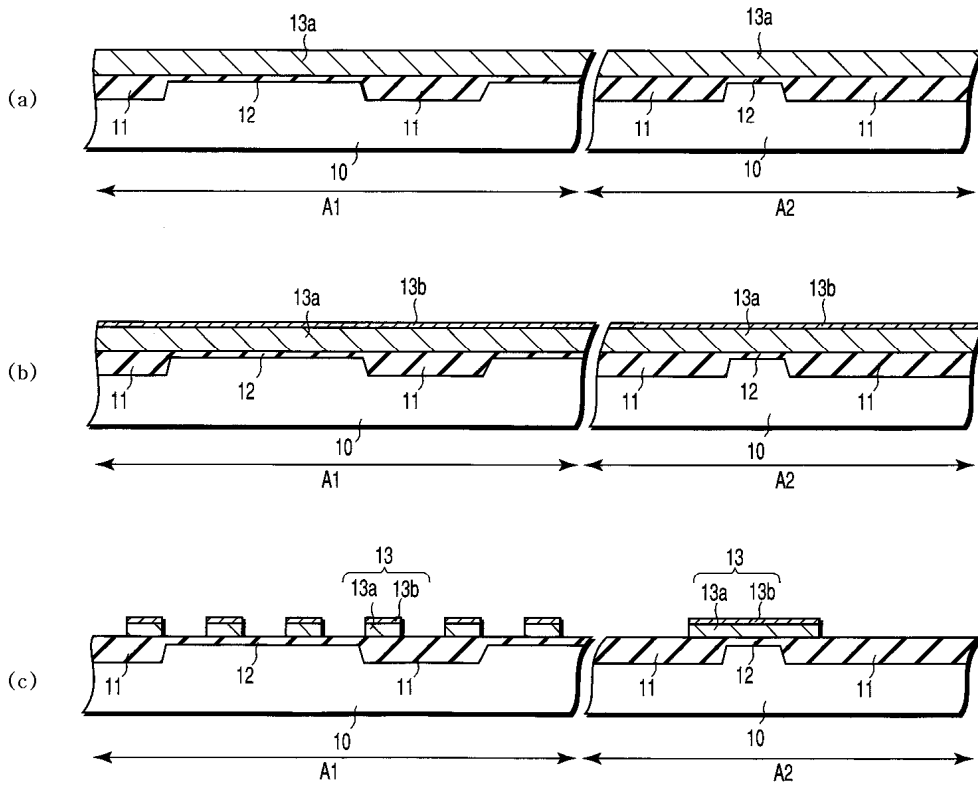

2a

(종래 기술)

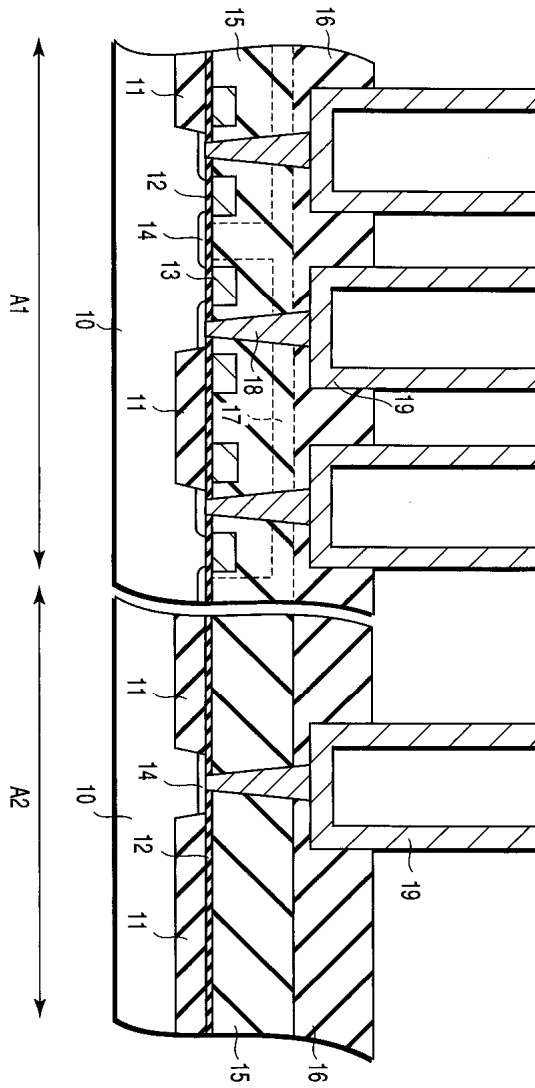

2b

(종래 기술)

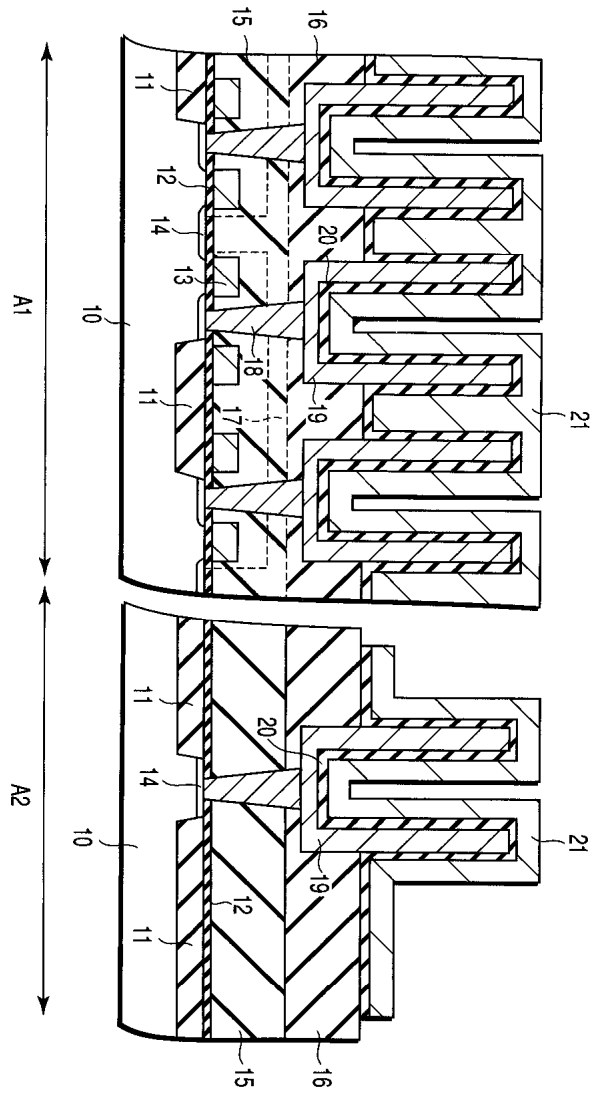

2c

(종래 기술)

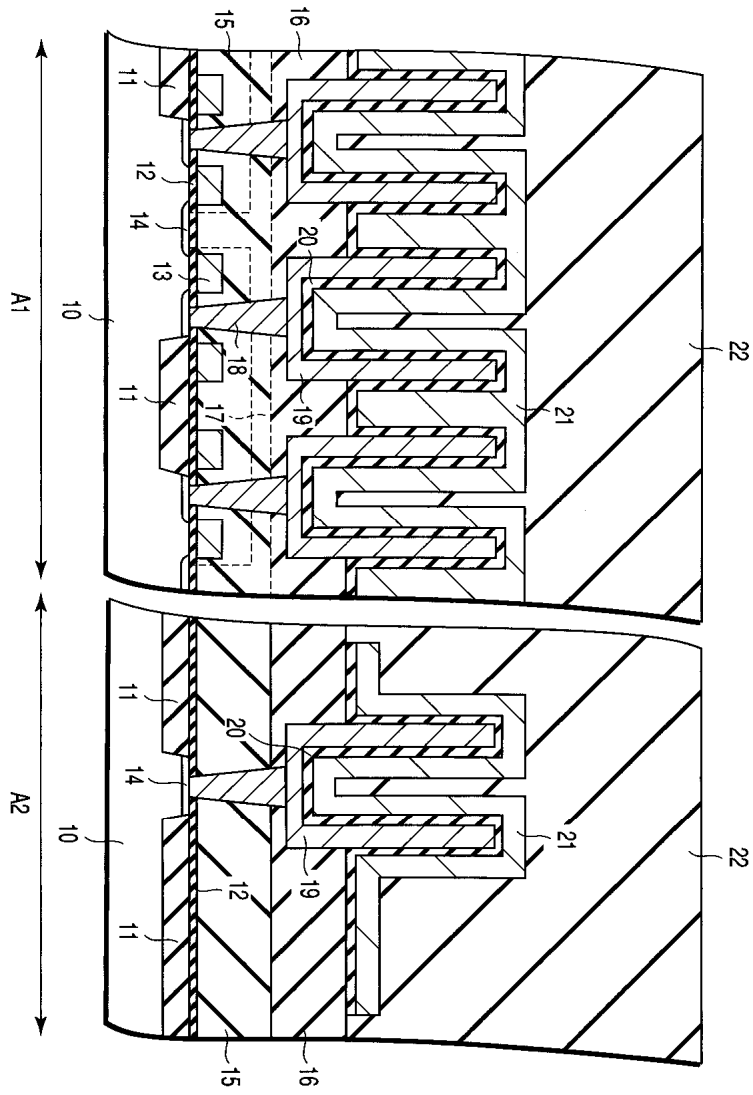

3

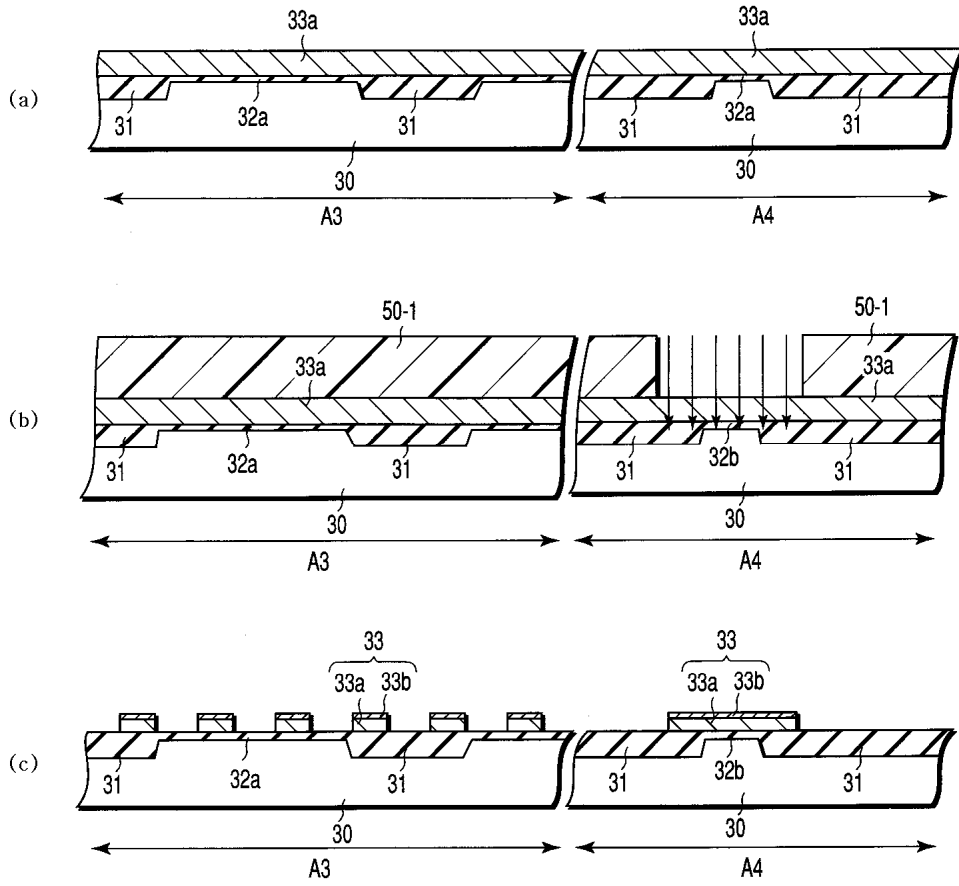

4

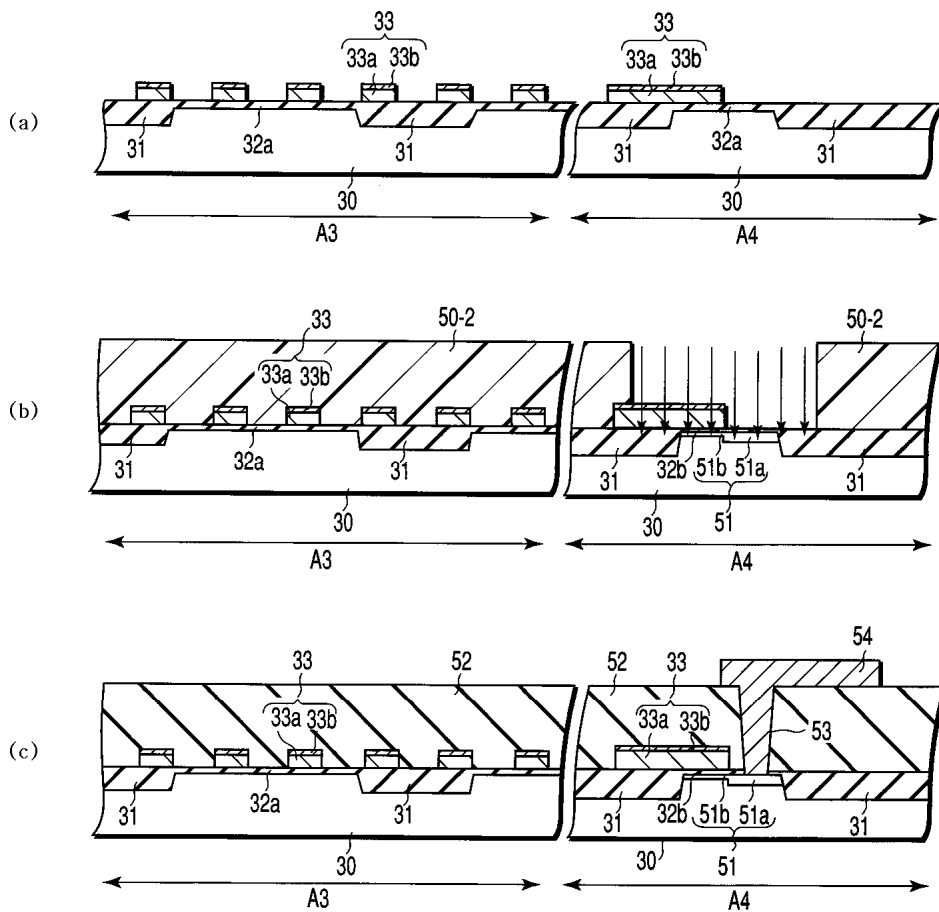

5a

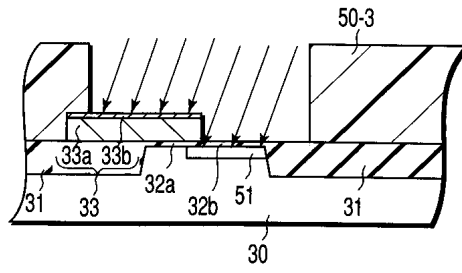

5b

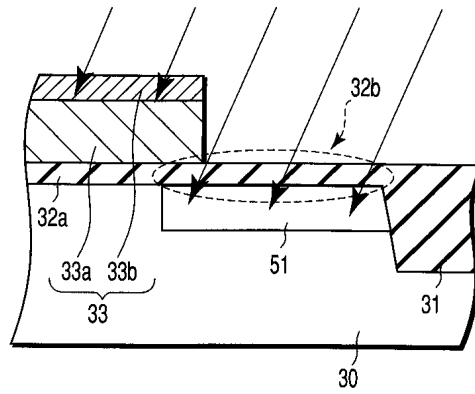

5c

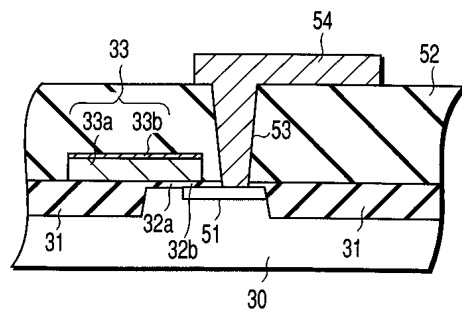

6a

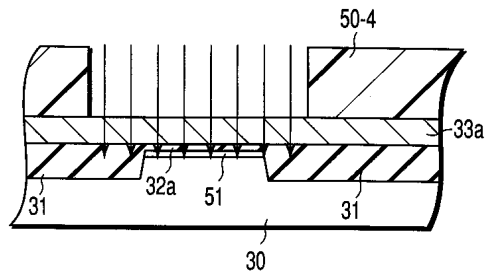

6b

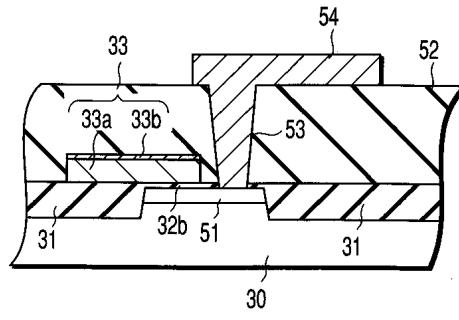

7a

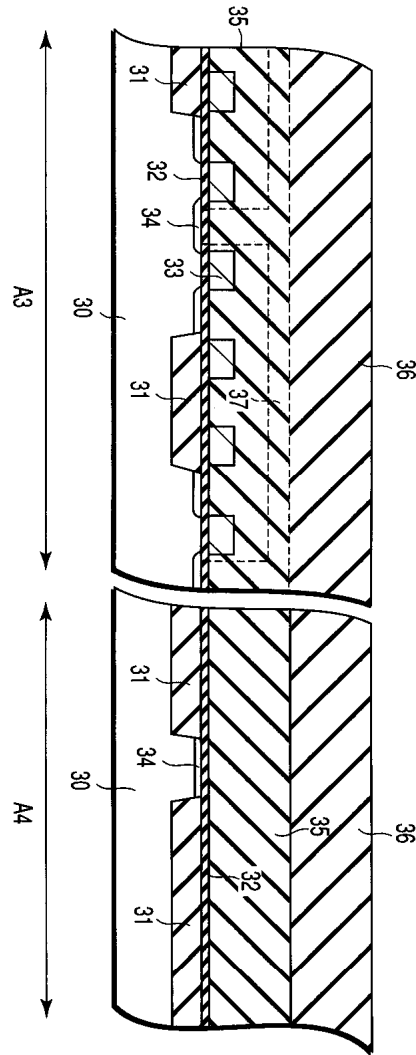

7b

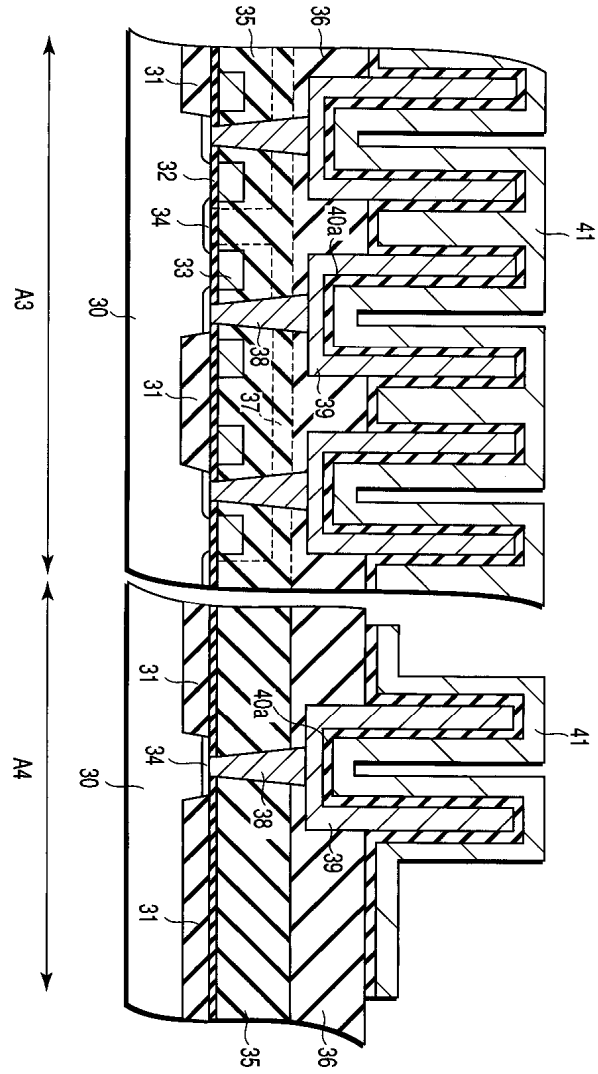

7c

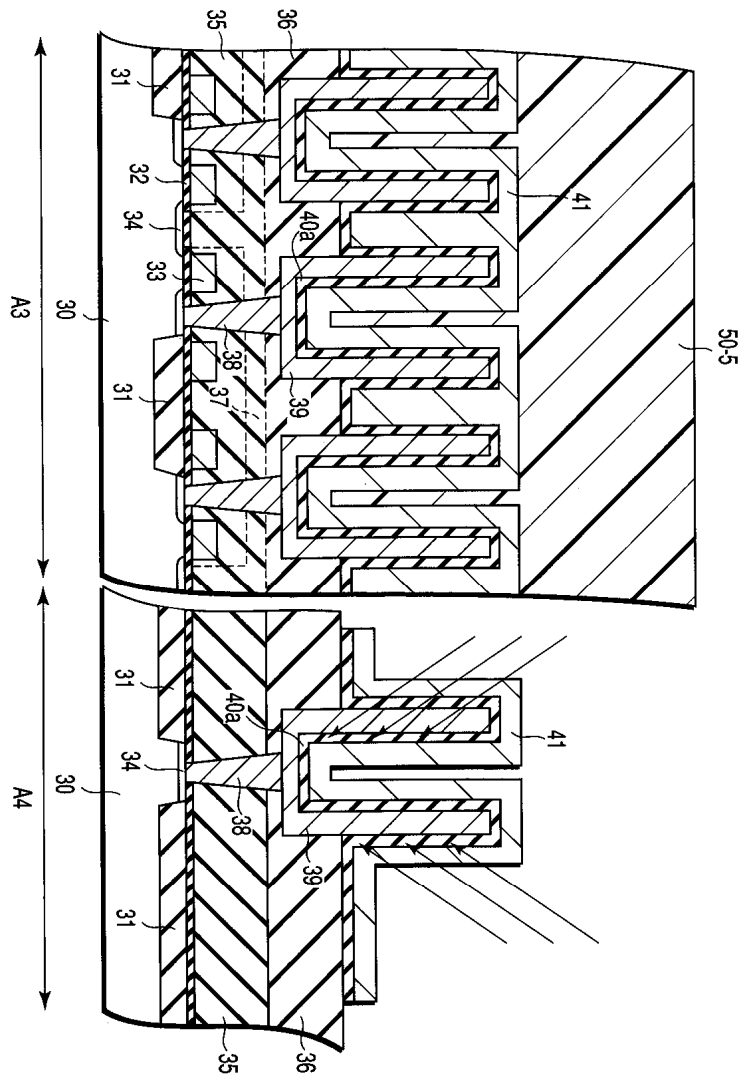

7d

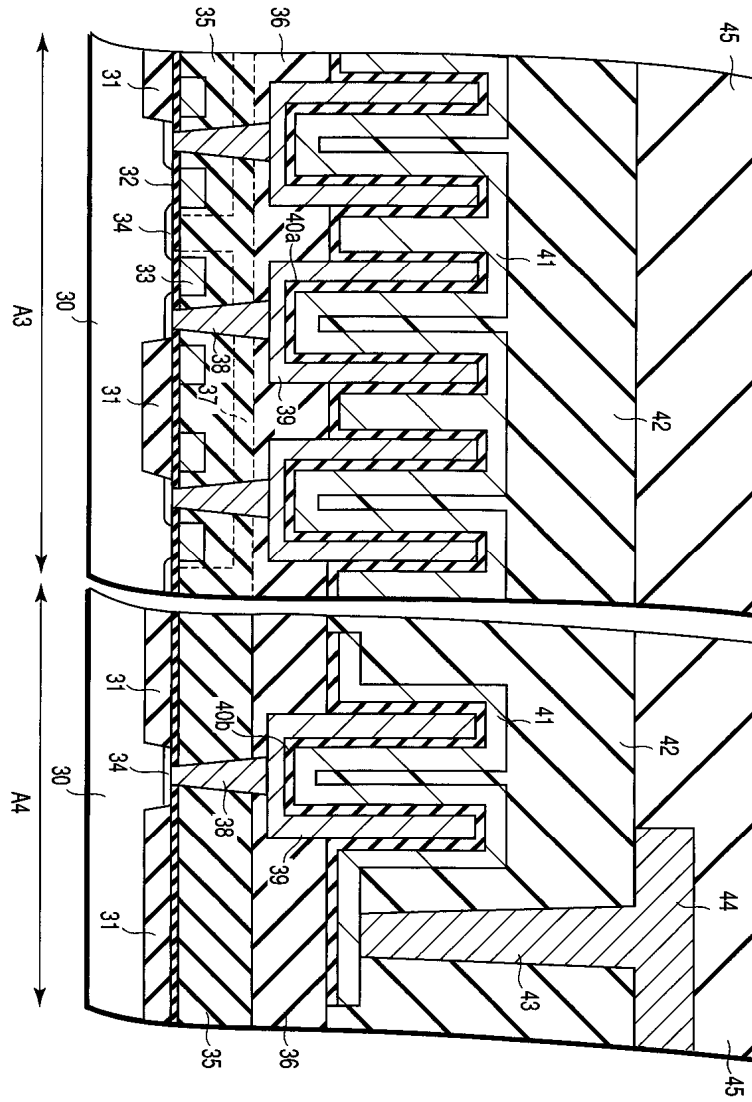

8a

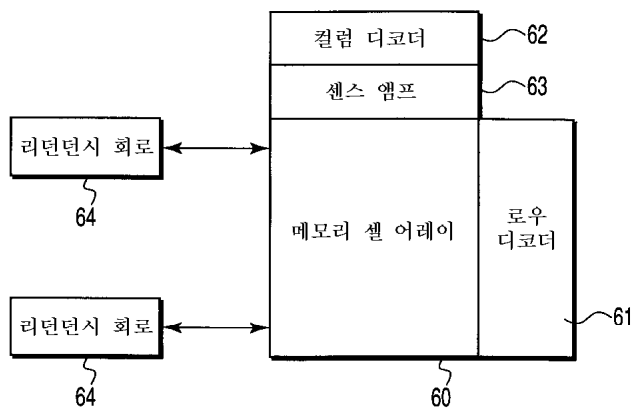

8b

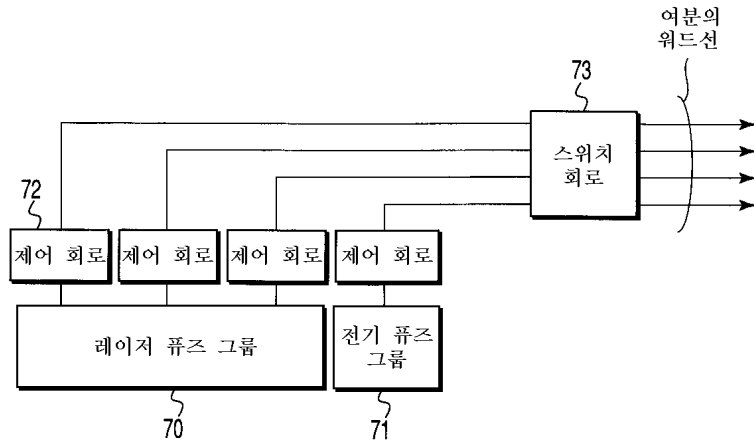

9a

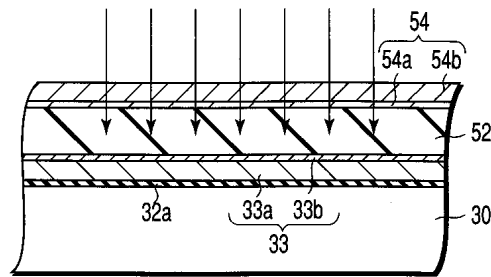

9b

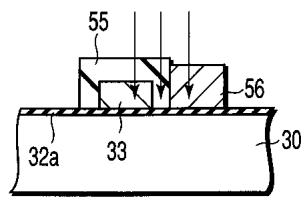

9c

