



(51) International Patent Classification:

G04F 10/02 (2006.01) G07C 1/24 (2006.01)  
A63B 71/06 (2006.01)

(21) International Application Number:

PCT/US2019/015237

(22) International Filing Date:

25 January 2019 (25.01.2019)

(25) Filing Language:

English

(26) Publication Language:

English

(71) Applicant: **EVERLAST CLIMBING INDUSTRIES, INC.** [US/US]; 42 Northern Stacks Drive, Suite 100, Minneapolis, Minnesota 55421 (US).

(72) Inventors: **STOCKINGER, Chris**; 1519 Gloria Ct., Loveland, Colorado 80537 (US). **JACOBS, Craig**; P.O. Box

1133, Lyons, Colorado 80540 (US). **JORDAN, Anne**; 1018 Pica Run, Fort Collins, Colorado 80524 (US). **MEDINA-BRODSKY, Michael**; 18 Vassar Ct., Longmont, Colorado 80503 (US). **BEDNARSKI, Vwodek**; 8353 Sheridan Ct., Arvada, Colorado 80003 (US).

(74) Agent: **SHERIDAN, Philip H.**; McAndrews, Held & Malloy, Ltd., 500 W. Madison, 34th Floor, Chicago, Illinois 60661 (US).

(81) Designated States (unless otherwise indicated, for every kind of national protection available): AE, AG, AL, AM, AO, AT, AU, AZ, BA, BB, BG, BH, BN, BR, BW, BY, BZ, CA, CH, CL, CN, CO, CR, CU, CZ, DE, DJ, DK, DM, DO, DZ, EC, EE, EG, ES, FI, GB, GD, GE, GH, GM, GT, HN, HR, HU, ID, IL, IN, IR, IS, JO, JP, KE, KG, KH, KN, KP, KR, KW, KZ, LA, LC, LK, LR, LS, LU, LY, MA, MD, ME, MG, MK, MN, MW, MX, MY, MZ, NA, NG, NI, NO, NZ, OM, PA, PE, PG, PH, PL, PT, QA, RO, RS, RU, RW, SA,

(54) Title: SYSTEM AND METHOD FOR SYNCHRONIZING ELECTRONIC TIMING DEVICES IN A WIRELESS TIMING SYSTEM

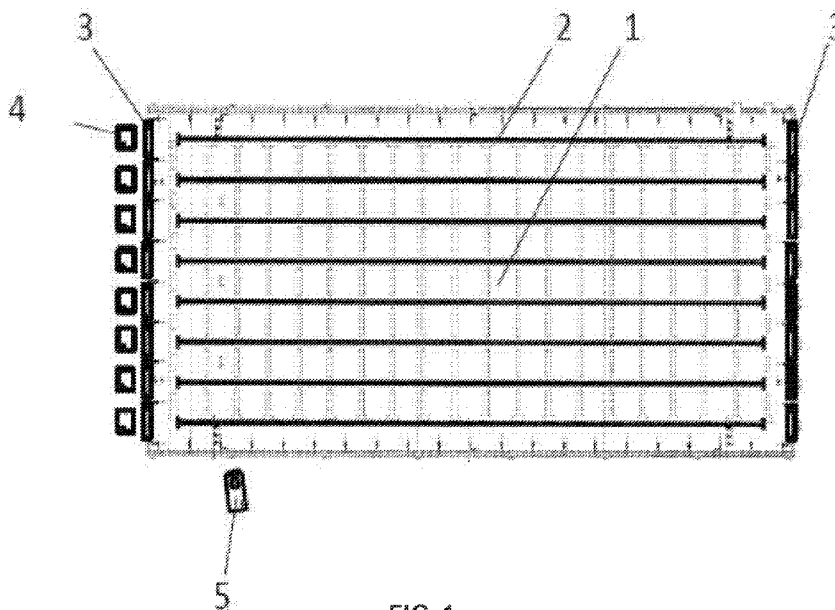

FIG. 1

(57) Abstract: Various embodiments provide a system and method for synchronizing electronic timing devices in a wireless timing system. The system may include at least one timing device having a communication component, a high accuracy synchronization receiver, and a processor. The communication component may be configured to transmit and receive information over a wireless network. The high accuracy synchronization receiver may be independent of the communication component and may be configured to periodically receive a high accuracy synchronization signal. The processor may include a local counter controlled by a local oscillator. The processor may be communicatively coupled to the communication component, the high accuracy synchronization receiver, and at least one timing component. The processor may be configured to receive the high accuracy synchronization signal from the high accuracy synchronization receiver and process the high accuracy synchronization signal to set the local counter to a defined value.



SC, SD, SE, SG, SK, SL, SM, ST, SV, SY, TH, TJ, TM, TN,  
TR, TT, TZ, UA, UG, US, UZ, VC, VN, ZA, ZM, ZW.

**(84) Designated States** (*unless otherwise indicated, for every kind of regional protection available*): ARIPO (BW, GH, GM, KE, LR, LS, MW, MZ, NA, RW, SD, SL, ST, SZ, TZ, UG, ZM, ZW), Eurasian (AM, AZ, BY, KG, KZ, RU, TJ, TM), European (AL, AT, BE, BG, CH, CY, CZ, DE, DK, EE, ES, FI, FR, GB, GR, HR, HU, IE, IS, IT, LT, LU, LV, MC, MK, MT, NL, NO, PL, PT, RO, RS, SE, SI, SK, SM, TR), OAPI (BF, BJ, CF, CG, CI, CM, GA, GN, GQ, GW, KM, ML, MR, NE, SN, TD, TG).

**Published:**

— *with international search report (Art. 21(3))*

---

SYSTEM AND METHOD FOR SYNCHRONIZING ELECTRONIC TIMING  
DEVICES IN A WIRELESS TIMING SYSTEM

FIELD

**[01]** Certain embodiments relate to electronic timing and scoring systems. More specifically, certain embodiments relate to a system and method for synchronizing timing devices in a wireless timing and scoring system that may be installed at swimming pools for timing and scoring aquatic sports. The wireless timing and scoring system includes a wireless network and a wireless synchronization channel independent of the wireless network to improve accuracy for measuring timing events.

## BACKGROUND

**[02]** Existing timing and scoring systems use timing devices configured to receive and process timing event inputs to measure times of competing athletes. For example, a timing and scoring system may be installed in a swimming pool to measure swim times. The timing and scoring system may include timing components, such as touch pads, pushbuttons, relay judging platforms, speakers, lights, or any suitable device or system that creates or presents a timing signal to at least one timing device. One or more of these timing components may be installed at ends of each swimming lane and connected to timing devices through mechanisms such as connection hubs, cable harnesses, and/or wireless communication components to form a timing and scoring system.

**[03]** More specifically, a touch pad may be located in the water at the end of a swimming lane and can create a timing signal when touched by a swimmer. Push buttons can be activated by timing officials when a swimmer finishes a race. A relay judging platform may detect when an athlete leaves a starting block. A start system may create a start signal, a start tone, and/or a visual start signal when activated by a swim official. Other timing components may communicate information to athletes, timing officials, and spectators. For example, one or more speakers may communicate commands and the start tone created by the start device. A light or series of lights may communicate a visual start signal. These timing components create timing signals, each of which may be provided to timing devices.

**[04]** Timing and scoring systems used for swim competitions may include at least two timing devices, each including an independent processing unit. The timing devices may each have its respective processing unit running in a local time domain controlled by a local oscillator. The timing devices may be configured to create a timing event having a signature of the timing device and a timestamp derived from the local time domain in response to receiving a timing signal from a timing component. The aggregate of all timing events of a system

is processed to calculate the results of a swim competition for further processing and display.

**[05]** The processor of the timing device may include a timer, also referred to as a counter, running in the local time domain that counts up by one in regular intervals, referred to as ticks. The timer may be used by the processor to generate the timestamp corresponding with a timing event. It is established practice for timers used in swim timing to have a tick resolution of at least one millisecond, and more preferably, higher resolutions, such as 250 microseconds. The processor of the timing device generates a timestamp having the current value of the timer in response to a received timing signal. The difference between the timestamps of two events can in principle be as small as one tick, such as 250 microseconds in the present example.

**[06]** The deviation of timestamps generated by a timing system for the duration of a race should be defined and repeatable relative to the official world time broadcasted by the National Institute of Standards and Technology. For example, the deviation of timestamps may be defined as less than one tick in 15 minutes, which is the range of world record times for the longest event recognized by FINA (Fédération internationale de natation, English: International Swimming Federation), the international federation recognized by the International Olympic Committee for administering international competition in aquatic sports. A frequency stability of a system having a deviation of one tick with a resolution of 250 microseconds in 15 minutes amounts to 278 parts per billion (ppb).

**[07]** In physical devices that are not constantly connected to the official world time generator, there is a difference between the counting rates, referred to as absolute drift. The absolute drift may be controlled by one higher accuracy oscillator and a limited duration of a given time measurement, such as 15 minutes for a race, for example. Once a new time measurement is started, the absolute drift is defined as being zero. Typically, one timing device of a system may be equipped with such a higher accuracy oscillator. The high cost of higher

accuracy oscillators makes it impractical for a swim timing system to utilize them in every timing device. Therefore, in a practical embodiment of a swim timing system, one higher accuracy oscillator is used in one timing device and lower accuracy oscillators are used in the at least one other timing device.

**[08]** In addition, the local time domains are synchronized at the beginning of a time measurement to a same value so that the timestamps of timing events are comparable with each other. Synchronization may occur by transmitting a signal that arrives at the counters of all timing devices to reset them. Ideally, the counters of the timing devices would be reset at the same time. In a typical system, however, the counters may be reset within a finite time span that is a fraction of the timing ticks employed. For example, the finite time span, also referred to as synchronization jitter, may be 50 microseconds when the tick resolution is 250 microseconds. The synchronization jitter may be dependent on the different processing times of the synchronization signal by the processors involved. For example, a first processor may be performing a task such that it is unable to process the synchronization request to reset the local counter until the task is completed. A second processor, however, may process the synchronization request immediately. Accordingly, the first processor may take a longer time than the second processor to execute the synchronization task. The time difference for executing the synchronization task is referred to as synchronization jitter.

**[09]** If multiple timing signals are received by respective timing devices at an exact same time, the resulting timestamps should be the same or within an allowed difference of one tick. Accordingly, the timers running in the local time domains of the timing devices should be within one tick at any given moment. To realize this feature, the timers of the timing device are set to a same value (i.e., synchronized) at the beginning of the time measurement and then count up according the respective local time domains. In physical devices that are not constantly connected, there is a difference between the counting rates, which is called relative drift, because the local time domains do not count at an exact same rate. In timing systems employing one higher accuracy oscillator and at

least one lower accuracy oscillator, the relative drift is primarily provided by the lower accuracy oscillator. For example, a lower accuracy oscillator may have a drift of 2000 ppb or 5000 ppb.

**[10]** To compensate for the relative drift of at least one other timing device, synchronization may be applied in regular intervals to synchronize the local time domains back to the same value. The value of the relative drift and the allowed difference in ticks defines the time interval at which synchronization should be applied. For example, if two local time domains have a relative drift of 5000 ppb and the allowed tick difference of the two local time domains is 250 microseconds, synchronization is applied every 50 seconds or less. Moreover, as mentioned above, the synchronization signal may be processed within the jitter time span, which is added to the synchronization requirements to arrive at a defined accuracy of the overall system.

**[11]** In timing systems having timing devices connected by wires, the above-mentioned synchronization requirements can be realized as demonstrated, for example, in the Gen7 system of Colorado Time Systems and as described in U.S. Patent No. 10,137,353 by Stockinger et al, which is incorporate by reference herein in its entirety. In the wired system, the timing devices with lower accuracy are connected by a bus to a timer with a higher accuracy oscillator. The timer periodically synchronizes the timing devices to compensate for absolute and relative drifts.

**[12]** In timing systems having wirelessly-connected timing devices, the above-mentioned synchronization requirements may not be realized using typical wireless radios to create networks (e.g., ZigBee) of timing devices. Specifically, existing networks of wireless radios are typically capable of a synchronization accuracy of about two milliseconds, which is eight times greater than the preferred tick resolution of 250 microseconds for an aquatic timing system. Moreover, creating a proprietary software stack of wireless radios to provide a wireless timing system with better quality synchronization and higher accuracy may be cost prohibitive. Wirelessly-connected timing systems with lower

accuracy have been realized as demonstrated in the product "Dolphin" by Colorado Time Systems developed according to the U.S. Patent No. 8,085,623 by Frantz, which is incorporated by reference herein in its entirety.

**[13]** Further limitations and disadvantages of conventional and traditional approaches will become apparent to one of skill in the art, through comparison of such systems with some aspects of the present disclosure as set forth in the remainder of the present application with reference to the drawings.

## BRIEF SUMMARY

**[14]** A system and/or method is provided for synchronizing electronic timing devices in a wireless timing system, substantially as shown in and/or described in connection with at least one of the figures, as set forth more completely in the claims.

**[15]** These and other advantages, aspects and novel features of the present disclosure, as well as details of an illustrated embodiment thereof, will be more fully understood from the following description and drawings.

## BRIEF DESCRIPTION OF SEVERAL VIEWS OF THE DRAWINGS

**[16]** FIG. 1 is a plan view of an exemplary pool with a start system and timing components having timing devices, in accordance with various embodiments.

**[17]** FIG. 2A is a side elevation view of an exemplary wireless start system with an independent synchronization transmitter, in accordance with various embodiments.

**[18]** FIG. 2B is a front elevation view of an exemplary wireless start system with an independent synchronization transmitter, in accordance with various embodiments.

**[19]** FIG. 2C is a plan view of an exemplary wireless start system with an independent synchronization transmitter, in accordance with various embodiments.

**[20]** FIG. 3A is a side elevation view of an exemplary wireless touchpad timing device with an independent synchronization receiver, in accordance with various embodiments.

**[21]** FIG. 3B is a front elevation view of an exemplary wireless touchpad timing device with an independent synchronization receiver, in accordance with various embodiments.

**[22]** FIG. 3C is a plan view of an exemplary wireless touchpad timing device with an independent synchronization receiver, in accordance with various embodiments.

**[23]** FIG. 4A is a side elevation view of an exemplary wireless relay judging platform timing device with an independent synchronization receiver, in accordance with various embodiments.

**[24]** FIG. 4B is a front elevation view of an exemplary wireless relay judging platform timing device with an independent synchronization receiver, in accordance with various embodiments.

**[25]** FIG. 4C is a plan view of an exemplary wireless relay judging platform timing device with an independent synchronization receiver, in accordance with various embodiments.

**[26]** FIG. 5 is a plan view of an exemplary pool with a start system and timing components having timing devices that are communicating wirelessly, in accordance with various embodiments.

**[27]** FIG. 6 is a plan view of an exemplary pool with a start system and timing components having timing devices during synchronization via an independent synchronization channel, in accordance with various embodiments.

**[28]** FIG. 7 is a block diagram of an exemplary timing device communicatively coupled with a timing component, in accordance with various embodiments.

**[29]** FIG. 8 is a block diagram of an exemplary high accuracy synchronization device, in accordance with various embodiments.

**[30]** FIG. 9 is a block diagram of an exemplary timing device configured to accept inputs from more than one timing component, in accordance with various embodiments.

## DETAILED DESCRIPTION

**[31]** Certain embodiments relate to electronic timing and scoring systems. More specifically, certain embodiments relate to a system and method for synchronizing timing devices in a wireless timing and scoring system that may be installed at swimming pools for timing and scoring aquatic sports. An example embodiment aids users by including the technical effect of providing timers (also referred to as counters) of timing devices running in local time domains having a high tick resolution (e.g., 250 microseconds) that improves accuracy for measuring timing events. The technical effect of high accuracy synchronization is achieved by providing a wireless timing and scoring system that includes a wireless network and a synchronization channel independent of the wireless network. For example, the timing devices may communicate wirelessly via radios forming a wireless network incapable of synchronizing the timing devices to a desired accuracy, such as the 250 microseconds. Accordingly, the high accuracy synchronization may be provided using a synchronization channel independent of the wireless network radios to at least some of the timing devices in the system. In various embodiments, the independent synchronization channel may be implemented using one or more mediums, such as light (e.g., infrared light, visible light, ultraviolet light, laser light, or the like), radio signals (e.g., the 27 MHz industrial, scientific, and medical (ISM) band or other frequencies in the ISM band), ultrasound, sonar, or any medium or combinations of media suitable for achieving the desired synchronization accuracy.

**[32]** The foregoing summary, as well as the following detailed description of certain embodiments will be better understood when read in conjunction with the appended drawings. To the extent that the figures illustrate diagrams of the functional blocks of various embodiments, the functional blocks are not necessarily indicative of the division between hardware circuitry. Thus, for example, one or more of the functional blocks (e.g., processors) may be implemented in a single piece of hardware (e.g., a general purpose signal processor or a block of random access memory, hard disk, or the like) or multiple

pieces of hardware. Similarly, the programs may be stand-alone programs, may be incorporated as subroutines in an operating system, may be functions in an installed software package, and the like. It should be understood that the various embodiments are not limited to the arrangements and instrumentality shown in the drawings. It should also be understood that the embodiments may be combined, or that other embodiments may be utilized and that structural, logical and electrical changes may be made without departing from the scope of the various embodiments of the present disclosure. The following detailed description is, therefore, not to be taken in a limiting sense, and the scope of the present disclosure is defined by the appended claims and their equivalents.

**[33]** As used herein, an element recited in the singular and proceeded with the word “a” or “an” should be understood as not excluding plural of the elements, unless such exclusion is explicitly stated. Furthermore, references to “an embodiment,” “one embodiment,” “a representative embodiment,” “an exemplary embodiment,” “various embodiments,” “certain embodiments,” and the like are not intended to be interpreted as excluding the existence of additional embodiments that also incorporate the recited features. Moreover, unless explicitly stated to the contrary, embodiments “comprising,” “including,” or “having” an element or a plurality of elements having a particular property may include additional elements not having that property.

**[34]** Furthermore, the term processor or processing unit, as used herein, refers to any type of processing unit that can carry out the disclosed calculations, such as single or multi-core: CPU, Graphics Board, DSP, FPGA, ASIC or a combination thereof.

**[35]** FIG. 1 is a plan view of an exemplary pool 1 with a start system 5 and timing components 3, 4 having timing devices, in accordance with various embodiments. Referring to FIG. 1, the pool 1 includes a plurality of lanes 2. A timing and scoring system is installed at the pool 1 and includes timing components 3, 4 and at least one start system 5. The timing components may include touchpads 3, relay judging platforms 4, and/or any suitable timing

components. The timing components 3, 4, may be configured at one or more lanes 2 of the pool 1 to record times of swimmers competing with each other. For example, the pool 1 of FIG. 1 includes 8 lanes with touchpads 3 on each end and one relay judging platform 4 at the start end. In the example of FIG. 1, there are sixteen (16) touchpads 3, eight (8) relay judging platforms 4, and one start system 5. In various embodiments, the timing components 3, 4 and the at least one start system 5 are each integrated and/or communicatively coupled with timing devices. The timing devices each include a radio communicatively coupled via a network and a high accuracy synchronization device independent of the radio as described below.

**[36]** FIG. 2A is a side elevation view of an exemplary wireless start system 5 with an independent synchronization transmitter 9, in accordance with various embodiments. FIG. 2B is a front elevation view of an exemplary wireless start system 5 with an independent synchronization transmitter 9, in accordance with various embodiments. FIG. 2C is a plan view of an exemplary wireless start system 5 with an independent synchronization transmitter 9, in accordance with various embodiments. In various embodiments, the wireless start system 5 of FIGS. 2A–C may be the start system 5 of FIG. 1. Referring to FIGS. 2A–C, the start system 5 comprises a strobe 6, a radio with antenna 7, a speaker 8, a high accuracy synchronization device 9, and a control panel 10. The start system 5 may be mounted on a structure to provide the desired positioning at the pool for starting a race and transmitting high accuracy synchronization signals to receivers in timing devices of the timing and scoring system, such as timing devices corresponding with each of the timing components 3, 4 of FIG. 1.

**[37]** Still referring to FIGS. 2A–C, the strobe 6 may be configured to provide visual start indications and other meet guidance in response to signals received from control panel 10 and/or an external controller remote from the start system 5. The radio with antenna 7 may comprise suitable logic, circuitry, interfaces and/or code that may be operable to wirelessly transmit and receive signals with other radios having antennas, such as radios corresponding with timing components 3, 4 of a timing and scoring system. For example, the radio with

antenna 7 may be configured to transmit and receive signals corresponding with timing events, meet results, and the like. The speaker 8 may be configured to provide auditory start signals in response to signals received from control panel 10 and/or an external controller. The control panel 10 may comprise suitable logic, circuitry, interfaces and/or code that may be operable to receive user input for controlling the start system 5 and/or the timing and scoring system.

**[38]** The high accuracy synchronization device 9 may comprise suitable logic, circuitry, interfaces and/or code that may be operable to transmit synchronization signals to one or more synchronization receivers provided at timing devices of timing components 3, 4 of a timing and scoring system. For example, the high accuracy synchronization device 9 may be configured to transmit synchronization signals to receivers at timing devices of timing components 3, 4 installed at a pool 1 as shown in FIG. 1. Additionally and/or alternatively, the high accuracy synchronization device 9 may be independent from the start system 5 or integrated with other timing devices other than the start system 5.

**[39]** In an exemplary embodiment, the high accuracy synchronization device 9 may transmit the synchronization signals via light (e.g., infrared light, visible light, ultraviolet light, laser light, or the like), radio signals (e.g., the 27 MHz ISM band or other frequencies in the ISM band), ultrasound, sonar, or any medium or combinations of media suitable for achieving the desired synchronization accuracy. The high accuracy synchronization device 9 is configured to periodically transmit the synchronization signals, which are received and processed by the timing devices to periodically synchronize the local time domains of the timing devices. For example, if two local time domains have a relative drift of 5000 ppb and the allowed tick difference of the two local time domains is 250 microseconds, the high accuracy synchronization device 9 may transmit the synchronization signals at least every 50 seconds or less to achieve the desired system accuracy. In various embodiments, the high accuracy synchronization device 9 may transmit the synchronization signals at smaller intervals, such as one every second, to ensure that the synchronization signals are received and synchronization is performed in a timely fashion. For example,

the more frequent synchronization signal transmissions may help ensure timely synchronization to achieve the desired high accuracy in cases where some of the synchronization signals may not be received by the high accuracy synchronization receivers at the timing devices, such as if an infrared light synchronization signal is obstructed or shadowed by swimmers, officials, waves, splashes, or the like.

**[40]** FIG. 3A is a side elevation view of an exemplary wireless touchpad timing device 12 with an independent synchronization receiver 13, in accordance with various embodiments. FIG. 3B is a front elevation view of an exemplary wireless touchpad timing device 12 with an independent synchronization receiver 13, in accordance with various embodiments. FIG. 3C is a plan view of an exemplary wireless touchpad timing device 12 with an independent synchronization receiver 13, in accordance with various embodiments. Referring to FIGS. 3A–C, the wireless touchpad timing device 12 may be integrated with or communicatively coupled to a touchpad 3 configured to receive a touch input that is provided to the timing device 12. The touchpad 3 may include a target marking 11 to provide a visual target for a swimmer. The touchpad 3 may include suitable logic, circuitry, interfaces and/or code that may be operable to generate and transmit a signal to the timing device 12 in response to a force (e.g., a touch input) provided at a surface of the touchpad 3.

**[41]** The timing device 12 may comprise suitable logic, circuitry, interfaces and/or code that may be operable to create a timing event having a signature of the timing device 12 and a timestamp derived from a local time domain in response to receiving the timing signal corresponding to the touch input from the touchpad timing component 3. For example, the timing device 12 may include a processing unit running in a local time domain controlled by a local oscillator. In various embodiments, the timing device 12 may include a radio and an independent synchronization receiver 13. The radio may comprise suitable logic, circuitry, interfaces and/or code that may be operable to communicate timing events, meet results, and the like via a wireless network to the start system 5 and/or other timing devices in the timing and scoring system. The

synchronization receiver 13 may comprise suitable logic, circuitry, interfaces and/or code that may be operable to receive synchronization signals, independent of wireless communications signals transmitted and/or received by the radio, that are provided to the timing device 12. The timing device 12 may be configured to synchronize the local time domain controlled by the local oscillator in response to the synchronization signals received via the synchronization receiver 13. The synchronization receiver 13 may be configured to receive synchronization signals transmitted via light (e.g., infrared light, visible light, ultraviolet light, laser light, or the like), radio signals (e.g., the 27 MHz ISM band or other frequencies in the ISM band), ultrasound, sonar, or any medium or combinations of media suitable for achieving the desired synchronization accuracy. For example, the synchronization receiver 13 may be configured to receive synchronization signals from a high accuracy synchronization device 9 as described above with respect to FIGS. 2A–C.

**[42]** FIG. 4A is a side elevation view of an exemplary wireless relay judging platform timing device 14 with an independent synchronization receiver 15, in accordance with various embodiments. FIG. 4B is a front elevation view of an exemplary wireless relay judging platform timing device 14 with an independent synchronization receiver 15, in accordance with various embodiments. FIG. 4C is a plan view of an exemplary wireless relay judging platform timing device 14 with an independent synchronization receiver 15, in accordance with various embodiments. Referring to FIGS. 4A–C, the wireless relay judging platform timing device 14 may be integrated with or communicatively coupled to a relay judging platform 4 configured to receive a pressure release input that is provided to the timing device 14, for example, when a swimmer leaves a starting block. For example, the relay judging platform 4 may be secured to a top surface of a swimming starting block such that a swimmer is on top of the relay judging platform 4 before the start of the race. The relay judging platform 4 may include suitable logic, circuitry, interfaces and/or code that may be operable to generate and transmit a signal to the timing device 14 in response to a force being removed from a surface of the relay judging platform 4, such as when a swimmer

dives off of the relay judging platform 4 secured to the starting block into the pool 1.

**[43]** The timing device 14 may comprise suitable logic, circuitry, interfaces and/or code that may be operable to create a timing event having a signature of the timing device 14 and a timestamp derived from a local time domain in response to receiving the timing signal corresponding to the touch input from the relay judging platform timing component 4. For example, the timing device 14 may include a processing unit running in a local time domain controlled by a local oscillator. In various embodiments, the timing device 14 may include a radio and an independent synchronization receiver 15. The radio may comprise suitable logic, circuitry, interfaces and/or code that may be operable to communicate timing events, meet results, and the like via a wireless network to the start system 5 and/or other timing devices in the timing and scoring system. The synchronization receiver 15 may comprise suitable logic, circuitry, interfaces and/or code that may be operable to receive synchronization signals, independent of wireless communications signals transmitted and/or received by the radio, that are provided to the timing device 14. The timing device 14 may be configured to synchronize the local time domain controlled by the local oscillator in response to the synchronization signals received via the synchronization receiver 15. The synchronization receiver 15 may be configured to receive synchronization signals transmitted via light (e.g., infrared light, visible light, ultraviolet light, laser light, or the like), radio signals (e.g., the 27 MHz ISM band or other frequencies in the ISM band), ultrasound, sonar, or any medium or combinations of media suitable for achieving the desired synchronization accuracy. For example, the synchronization receiver 15 may be configured to receive synchronization signals from a high accuracy synchronization device 9 as described above with respect to FIGS. 2A–C.

**[44]** FIG. 5 is a plan view of an exemplary pool 1 with a start system 5 and timing components 3, 4 having timing devices that are communicating wirelessly, in accordance with various embodiments. Referring to FIG. 5, the pool 1 may include lanes 2 and a timing and scoring system installed at the pool 1. For

example, FIG. 5 illustrates relay judging platforms 4 positioned at the start end of each of the eight (8) pool lanes 2, touchpads 3 positioned at both ends of each of the pool lanes 2, and a start system 5 positioned adjacent the pool 1. The bowed arrows 16 are a simplified representation of exemplary wireless network communication signals transmitted between radios in the timing devices of the timing components 3, 4 and start system 5 of the timing and scoring system. The wireless network sub-system may be configured to provide the communication within the system with the exception of the high accuracy synchronization provided by an independent synchronization channel.

**[45]** FIG. 6 is a plan view of an exemplary pool 1 with a start system 5 and timing components 3, 4 having timing devices during synchronization via an independent synchronization channel, in accordance with various embodiments. Referring to FIG. 6, a timing and scoring system is installed at a pool 1 having multiple lanes 2. The timing and scoring system may include a start system 5 positioned at or near the pool 1, touchpad timing components 3 installed at each end of each lane 2, and relay judging platform components 4 installed at the start end of each lane 2. The start system 5 may include a high accuracy synchronization device 9 comprising suitable logic, circuitry, interfaces and/or code that may be operable to transmit synchronization signals 17 to one or more synchronization receivers provided at timing devices of the timing components 3, 4. The timing devices of the timing components 3, 4 may comprise suitable logic, circuitry, interfaces and/or code that may be operable to receive and process the synchronization signals 17 to synchronize the local time domains controlled by each of the local oscillators of each of the timing devices, such that the timing devices operate with a high accuracy corresponding with a desired tick resolution. The synchronization signals 17 are transmitted by the high accuracy synchronization device 9 and received by high accuracy synchronization receivers independent from the wireless network sub-system described above with respect to FIG. 5.

**[46]** FIG. 7 is a block diagram of an exemplary timing device 18 communicatively coupled with a timing component 25, in accordance with various

embodiments. Referring to FIG. 7, a timing device 18 connected to a timing component 25 is shown. The timing component 25 may be, for example, a touchpad 3, relay judging platform 4, or any suitable timing component. The timing device 18 may include a radio 19, a high accuracy synchronization receiver 21, and a processing unit 23. The radio 19 may include an antenna 20 configured to transmit and receive wireless signals 16. For example, the wireless signals 16 may include timing events, meet results, and/or any suitable information other than synchronization signals.

**[47]** The processing unit 23 may comprise a local counter 24 and a local oscillator 26. The processing unit 23 comprises suitable logic, circuitry, interfaces and/or code that may be operable to generate a timestamp having a current value of the local counter 24 in response to receiving a timing signal from the timing component 25. The processing unit 23 may create a timing event having a signature of the timing device 18 and the timestamp. The timing event may be buffered and provided to the radio 19 for wireless transmission 16 to a start system 5 or timing device 18 via the antenna 20. The wireless communications signals 16 may be received by the start system 5 or other timing device 18 after a time duration that is considered non-critical. The start system 5 or other timing device 18 collects and processes the received timestamped timing events to calculate times and scores. The calculated times and scores may be transmitted from the start system 5 or other timing device 18 for storage and/or display, for example, at scoreboards, timers, and web databases, among other things.

**[48]** The high accuracy synchronization receiver 21 may comprise a receiving structure 22 configured to receive high accuracy synchronization signals 17. The receiving structure 22 may correspond with the type of synchronization signals being received, such as light (e.g., infrared light, visible light, ultraviolet light, laser light, or the like), radio signals (e.g., the 27 MHz ISM band or other frequencies in the ISM band), ultrasound, sonar, or any medium or combinations of media suitable for achieving the desired synchronization accuracy. The high accuracy synchronization receiver 21 may provide the high accuracy

synchronization signals 17 received via the receiving structure 22 to the processing unit 23 for synchronizing the local counter 24 within a synchronization jitter. For example, the processing unit 23 may process the high accuracy synchronization signals 17 to set the local counter 24 to a defined value. The same high accuracy synchronization signals 17 may be received by several timing devices 18 at a same time such that the local counter 24 of each timing device is set to a same value and the system is synchronized within the synchronization jitter. In various embodiments, the local oscillator 26 may have a lower accuracy compared to the oscillator for which the synchronization signals 17 are based. As time elapses, the processing unit 23 counts up the local counter 24 with the local oscillator 26 having the lower accuracy, thereby accruing absolute and relative drifts that may be reset by synchronizing the local oscillator 26 in response to received synchronization signals 17. The synchronization signals 17 may be repeatedly sent at a time interval determined to maintain the absolute and relative drifts within a defined value, such as a 250 microsecond tick resolution.

**[49]** FIG. 8 is a block diagram of an exemplary high accuracy synchronization device 27, in accordance with various embodiments. In various embodiments, the high accuracy synchronization device 27 may be integrated and/or communicatively coupled with a start system 5, such as the start system 5 illustrated in FIGS. 1, 2A–C, 5 and 6. Referring to FIG. 8, the high accuracy synchronization device 27 may comprise a radio 19, a high accuracy synchronization transmitter 28, and a processing unit 30. The radio 19 may include an antenna 20 configured to transmit and receive wireless signals 16. For example, the wireless signals 16 may include timing events, meet results, and/or any suitable information other than synchronization signals.

**[50]** The processing unit 30 may comprise a master counter 32 that is controlled by a high accuracy oscillator 31. The high accuracy oscillator 31 may have a higher accuracy than local oscillators 26 used in timing devices 18 as described above with respect to FIG. 7, for example. The processing unit 30 comprises suitable logic, circuitry, interfaces and/or code that may be operable to

calculate a time interval determined suitable to maintain the absolute and relative drifts of the local oscillators 26 of the timing devices 18 within a certain value, such as a 250 microsecond tick resolution, based on values in the master counter 32. The processing unit 30 may be configured to trigger the high accuracy synchronization transmitter 28 to transmit a high accuracy synchronization signal 17 via the transmitting device 29 to receiving timing devices 18 in range of the high accuracy synchronization transmitter 28 when the calculated timer interval has elapsed. The processing unit 30 may be configured to collect and process timestamped timing events wirelessly transmitted 18 from timing devices 18 and received at radio 19 via antenna 20. The timestamped timing events may be processed by the processing unit 30 to calculate times and scores. The calculated times and scores may be transmitted from the high accuracy synchronization device 27 for storage and/or display, for example, at scoreboards, timers, and/or web databases, among other things.

**[51]** The high accuracy synchronization transmitter 28 may comprise a transmitting device 29 configured to transmit high accuracy synchronization signals 17 to timing devices 18. The transmitting device 29 may correspond with the type of synchronization signals being transmitted, such as light (e.g., infrared light, visible light, ultraviolet light, laser light, or the like), radio signals (e.g., the 27 MHz ISM band or other frequencies in the ISM band), ultrasound, sonar, or any medium or combinations of media suitable for achieving the desired synchronization accuracy.

**[52]** For example, the transmitting device 29 may be an infrared diode with an optical lens arranged to reach the desired timing devices of timing components 3, 4 in a pool 1 as shown in FIG. 6 if the synchronization signals 17 are transmitted via infrared light. In the case of infrared light, the path of the higher accuracy synchronization signal 17 may be obstructed or shadowed by swimmers, officials, waves, splashes, and the like. Since a meet is a highly dynamic environment where athletes get in and out of the water constantly and officials move around, there may be time spans where no obstructions occur between the transmitting device 29 and corresponding receiving structure 22 in a given timing

device 18 and time spans where obstructions do occur. The high accuracy synchronization device 27 may utilize a higher frequency of synchronizations than needed, called over-synchronization, to reduce the likelihood of timing devices 18 getting out of synchronization because the synchronization signal 17 has been obstructed. In various embodiments, an obstruction may occur for the time duration it takes for a timing device 18 with lower accuracy to fall out of synchronization. For example, if a maximum synchronization time of 50 seconds corresponds to the desired accuracy and the synchronization signals are sent every second, an obstruction may occur at any point in time that is up to 50 seconds long before the obstructed timing device 18 falls out of synchronization. If indeed an obstruction exceeds the maximum synchronization time and one or more timing devices 18 fall out of synchronization, the system may switch to a lower accuracy synchronization via wireless signals 16 transmitted and received using radios 19 having antennas 20. The timing events generated during the lower accuracy synchronization may be marked to indicate that the timing events were generated during the non-synchronized state. The timing system and/or the user may determine whether to use such timing events with lower accuracy synchronization. In an exemplary embodiment, additional measures may be taken to validate that the receiving structure 22 of a given timing device 18 received the infrared light signal 17 from the transmitting device 29 before the system is used for timing with higher accuracy synchronization. For example, the timing device 18 may transmit a wireless signal 16 via the radio 19 with the antenna 20 to the high accuracy synchronization device 27 to confirm receipt of the high accuracy synchronization signals 17.

**[53]** As another example, the transmitting device 29 may be a radio configured for the generation and transmission of higher accuracy synchronization signals, such as in the ISM band. The timing devices 18 are equipped with the corresponding receiver structure 22 and processing operability for synchronizing the local time domains. In an exemplary embodiment, over-synchronization may be utilized as a safety measure in such a configuration to reduce the likelihood of timing devices 18 getting out of synchronization because the synchronization

signal 17 has been obstructed, for example, in the case of water splashed on the receiver structure 22 of a timing device 18 obscuring the synchronization signal 17. In certain embodiments, additional measures may be taken to validate that at least one receiver structure 22 of a given timing device 18 received the radio signal 17 from the transmitting device 29 before the system is used for timing with higher accuracy synchronization. For example, the timing device 18 may transmit a wireless signal 16 via the radio 19 with the antenna 20 to the high accuracy synchronization device 27 to confirm receipt of the high accuracy synchronization signals 17.

**[54]** Additionally and/or alternatively, the transmitting device 29 may be configured to transmit the high accuracy synchronization signals 17 using a laser light in the invisible light spectrum or the visible light spectrum. The timing devices 18 are equipped with the corresponding receiver structure 22 and processing operability for synchronizing the local time domains. In certain embodiments, over-synchronization may be utilized as a safety measure in such a configuration to reduce the likelihood of timing devices 18 getting out of synchronization because the synchronization signal 17 has been obstructed, for example, in the case of the receiver structure 22 of a timing device 18 being shaded by swimmers, officials, waves, splashes, or the like. In an exemplary embodiment, additional measures may be taken to validate that at least one receiver structure 22 of a given timing device 18 received the laser signal 17 from the transmitting device 29 before the system is used for timing with higher accuracy synchronization. For example, the timing device 18 may transmit a wireless signal 16 via the radio 19 with the antenna 20 to the high accuracy synchronization device 27 to confirm receipt of the high accuracy synchronization signals 17.

**[55]** As another example, the transmitting device 29 may be an ultrasound transducer configured to generate and transmit high accuracy synchronization ultrasound signals 17. The timing devices 18 are equipped with the corresponding ultrasound transducer receiver structure 22 and processing operability for synchronizing the local time domains. In a representative

embodiment, over-synchronization may be utilized as a safety measure in such a configuration to reduce the likelihood of timing devices 18 getting out of synchronization because the synchronization signal 17 has been obstructed, for example, in the case of the receiver structure 22 of a timing device 18 being exposed to loud noises or hits by the athletes or others obscuring the synchronization signal 17. In various embodiments, additional measures may be taken to compensate for the slow propagation speed of a sound signal in air compared to electromagnetic waves. For example, the parameters of the air affecting the propagation speed and the distribution of the system may be determined and the distances between the transmitting device 29 and each receiver structure 22 may be calculated. The time delay stemming from the propagation of the synchronization sound signal 17 may be calculated from the spatial distances and the air parameters and applied by the high accuracy synchronization device 27 to synchronize the timing device 18 to higher accuracy. As an example, the high accuracy synchronization device 27 may consider that the propagation time, also referred to as time delay of sound, over 50 meters is about 146 milliseconds or about 584 times a tick of 250 microseconds. In various embodiments, additional measures may be taken to validate that at least one receiver structure 22 of a given timing device 18 received the ultrasound signal 17 from the transmitting device 29 before the system is used for timing with higher accuracy synchronization. For example, the timing device 18 may transmit a wireless signal 16 via the radio 19 with the antenna 20 to the high accuracy synchronization device 27 to confirm receipt of the high accuracy synchronization signals 17.

**[56]** In certain embodiments, the transmitting device 29 may be a sonar (underwater sound) transmitter configured to generate and transmit high accuracy synchronization ultrasound signals 17. The sonar transmitting device 29 is positioned to reach into the water. The timing devices 18 are equipped with the corresponding receiver structure 22 that reaches into the water and processing operability for synchronizing the local time domains. In an exemplary embodiment, over-synchronization may be utilized as a safety measure in such a

configuration to reduce the likelihood of timing devices 18 getting out of synchronization because the synchronization signal 17 has been obstructed, for example, in the case of the receiver structure 22 of a timing device 18 being exposed to loud noises or hits by the athletes or others obscuring the synchronization signal 17. In various embodiments, additional measures may be taken to compensate for the slow propagation speed of a sound signal in water compared to electromagnetic waves. For example, the parameters of the water affecting the propagation speed and the distribution of the system may be determined and the distances between the transmitting device 29 and each receiver structure 22 may be calculated. The time delay stemming from the propagation of the synchronization sound signal 17 may be calculated from the spatial distances and the water parameters and applied by the high accuracy synchronization device 27 to synchronize the timing device 18 to higher accuracy. As an example, the high accuracy synchronization device 27 may consider that the propagation time over 50 meters is about 33 milliseconds or about 132 times a tick of 250 microseconds. In various embodiments, additional measures may be taken to validate that at least one receiver structure 22 of a given timing device 18 received the sonar signal 17 from the transmitting device 29 before the system is used for timing with higher accuracy synchronization. For example, the timing device 18 may transmit a wireless signal 16 via the radio 19 with the antenna 20 to the high accuracy synchronization device 27 to confirm receipt of the high accuracy synchronization signals 17.

**[57]** In various embodiments, two or more types of transmitting devices 29 (e.g., laser, radio, and/or ultrasound) may be configured to generate and transmit the high accuracy synchronization signals 17. The timing devices 18 are equipped with at least one of the corresponding receiver structures 22 and processing operability for synchronizing the local time domains according to at least one of the transmission media. The use of multiple transmitting devices 29 and receiver structures 22 provides redundancy and increased robustness in the case one or several of the synchronization signals 17 are shadowed or obscured, preventing them from reaching the appropriate receiver structure 22 and thus

being utilized for high accuracy synchronization. In certain embodiments, one or more of the transmitting devices 29 may implement over-synchronization as an additional safety measure in such a system.

**[58]** FIG. 9 is a block diagram of an exemplary timing device 18 configured to accept inputs from more than one timing component 3, 4, 33, in accordance with various embodiments. Referring to FIG. 9, a timing device 18 connected to multiple timing components 3, 4, 33 is shown. The timing components may include, for example, a touchpad 3, relay judging platform 4, push buttons 33, or any suitable timing component. The timing device 18 may include a radio 19, a high accuracy synchronization receiver 21, and a processing unit 23. The radio 19 may include an antenna 20 configured to transmit and receive wireless signals 16. For example, the wireless signals 16 may include timing events, meet results, and/or any suitable information other than synchronization signals. The timing devices 18 connected with multiple inputs 3, 4, 33 may be advantageous at least because the costs for radios 19, receivers 21, and processing units 23 can be shared between more than one timing component 3, 4, 33. The resulting wireless system formed by the radios 19 includes fewer wireless participants, which reduces the complexity of the operation of the wireless system.

**[59]** The processing unit 23 may comprise a local counter 24 and a local oscillator 26. The processing unit 23 comprises suitable logic, circuitry, interfaces and/or code that may be operable to generate a timestamp having a current value of the local counter 24 in response to receiving a timing signal from a timing component 3, 4, 33. The processing unit 23 may create a timing event having a signature corresponding with the appropriate timing component 3, 4, 33 and the timestamp. The timing event may be buffered and provided to the radio 19 for wireless transmission 16 to a start system 5, a high accuracy synchronization device 27, or other timing device 18 via the antenna 20. The wireless communications signals 16 may be received by the start system 5, the high accuracy synchronization device 27, or other timing device 18 after a time duration that is considered non-critical. The start system 5, the high accuracy

synchronization device 27, or other timing device 18 collects and processes the received timestamped timing events to calculate times and scores. The calculated times and scores may be transmitted from the start system 5, the high accuracy synchronization device 27, or other timing device 18 for storage and/or display, for example, at scoreboards, timers, and/or web databases, among other things.

**[60]** The high accuracy synchronization receiver 21 may comprise a receiving structure 22 configured to receive high accuracy synchronization signals 17. The receiving structure 22 may correspond with the type of synchronization signals being received. The high accuracy synchronization receiver 21 may provide the high accuracy synchronization signals 17 received via the receiving structure 22 to the processing unit 23 for synchronizing the local counter 24 within a synchronization jitter. In various embodiments, the local oscillator 26 may have a lower accuracy compared to the oscillator for which the synchronization signals 17 are based. As time elapses, the processing unit 23 counts up the local counter 24 with the local oscillator 26 having the lower accuracy, thereby accruing absolute and relative drifts that may be reset by synchronizing the local oscillator 26 in response to received synchronization signals 17. The synchronization signals 17 may be repeatedly sent at a time interval determined to maintain the absolute and relative drifts within a defined value, such as a 250 microsecond tick resolution.

**[61]** In accordance with various embodiments, a system and method for synchronizing electronic timing devices 12, 14, 18 in a wireless timing system is provided. The system may comprise at least one timing device 12, 14, 18 comprising a timing device communication component 19, 20, a high accuracy synchronization receiver 13, 15, 21 and a timing device processor 23. The timing device communication component 19, 20 may be configured to transmit and receive information 16 over a wireless network. The high accuracy synchronization receiver 13, 15, 21 is independent of the timing device communication component 19, 20 and may be configured to periodically receive a high accuracy synchronization signal 17. The timing device processor 23 may

comprise a local counter 24 controlled by a local oscillator 26. The timing device processor 23 may be communicatively coupled to the timing device communication component 19, 20, the high accuracy synchronization receiver 13, 15, 21 and at least one timing component 3, 4, 25, 33. The timing device processor 23 may be configured to receive the high accuracy synchronization signal 17 from the high accuracy synchronization receiver 13, 15, 21. The timing device processor 23 may be configured to process the high accuracy synchronization signal 17 to set the local counter 24 to a defined value.

**[62]** In an exemplary embodiment, the timing device processor 23 may be configured to receive a timing signal from the at least one timing component 3, 4, 25, 33. The timing device processor 23 may be configured to generate a timestamp having a current value of the local counter 24 associated with a time the timing signal is received. The timing device processor 23 may be configured to create a timing event comprising the timestamp and a signature associated with one or both of the timing device 12, 14, 18 and the at least one timing component 3, 4, 25, 33. The timing device processor 23 may be configured to communicate the timing event 16 via the timing device communication component 19, 20. In a representative embodiment, the at least one timing component 3, 4, 25, 33 may be a plurality of timing components 3, 4, 25, 33. The timing device processor 23 may be configured to create the timing event based on the timestamp generated in response to the timing signal received from any of the plurality of timing components 3, 4, 25, 33.

**[63]** In certain embodiments, the high accuracy synchronization receiver 13, 15, 21 comprises a receiver structure 22 corresponding to a type of the high accuracy synchronization signal 17 being periodically received. In various embodiments, the type of the high accuracy synchronization signal 17 is one of infrared light, visible light, ultraviolet light, or laser light. In an exemplary embodiment, the type of the high accuracy synchronization signal 17 is a radio signal. In a representative embodiment, the radio signal 17 may be provided in an industrial, scientific, and medical (ISM) band. In certain embodiments, the type of the high accuracy synchronization signal 17 is an ultrasound signal. In

various embodiments, the type of the high accuracy synchronization signal 17 is a sonar signal.

**[64]** In a representative embodiment, the timing device processor 23 is configured to communicate a wireless signal 16 via the timing device communication component 19, 20 to confirm receipt of the high accuracy synchronization signal 17. In certain embodiments, the high accuracy synchronization receiver 13, 15, 21 is configured to periodically receive the high accuracy synchronization signal 17 of a first type. The at least one timing device 12, 14, 18 may comprise an additional high accuracy synchronization receiver 13, 15, 21 independent of the timing device communication component 19, 20, configured to periodically receive an additional high accuracy synchronization signal 17 of a second type that is different from the first type. In various embodiments, the system comprises a plurality of the at least one timing device 12, 14, 18.

**[65]** In an exemplary embodiment, the system comprises a high accuracy synchronization device 9, 27 that may include a high accuracy synchronization device communication component 7, 19, 20, a high accuracy synchronization transmitter 28, 29, and a high accuracy synchronization device processor 30. The high accuracy synchronization device communication component 7, 19, 20 may be configured to transmit and receive information 16 over the wireless network. The high accuracy synchronization transmitter 28, 29 may be independent of the high accuracy synchronization device communication component 19, 20 and may be configured to periodically transmit the high accuracy synchronization signal 17. The high accuracy synchronization device processor 30 may comprise a master counter 32 controlled by a high accuracy oscillator 31. The high accuracy synchronization device processor 30 may be communicatively coupled to the a high accuracy synchronization device communication component 7, 19, 20 and the high accuracy synchronization transmitter 28, 29. The high accuracy synchronization device processor 30 may be configured to calculate a time interval based at least in part on one or both of a relative drift and an absolute drift of the local oscillator of the at least one timing

device 12, 14, 18. The high accuracy synchronization device processor 30 may be configured to trigger the high accuracy synchronization transmitter 28, 29 to transmit the high accuracy synchronization signal 17 when the time interval has elapsed.

**[66]** In various embodiments, the time interval may be defined based at least in part on a desired tick resolution. In certain embodiments, the desired tick resolution may be 250 microseconds or less. In a representative embodiment, the time interval may be defined to provide over-synchronization such that a plurality of high accuracy synchronization signals 17 are transmitted by the high accuracy synchronization transmitter 28, 29 prior to a maximum time interval for achieving the desired tick resolution. In an exemplary embodiment, each of the timing device communication component 19, 20 and the high accuracy synchronization device communication component 7, 19, 20 may comprise a transceiver 19 and an antenna 20. In various embodiments, the high accuracy synchronization device 9, 27 is one of integrated with or communicatively coupled to a start system 5. In certain embodiments, the high accuracy oscillator 31 has a higher accuracy than the local oscillator 26 of the at least one timing device 12, 14, 18. In a representative embodiment, the high accuracy synchronization transmitter 28, 29 may comprise a transmitting device 29 having an infrared diode with an optical lens. In an exemplary embodiment, the at least one timing component 3, 4, 33 is one or more of a touch pad 3, a push button 33, and a relay judging platform 4.

**[67]** In certain embodiments, the high accuracy synchronization transmitter 28, 29 may comprise a transmitting device 29 having an ultrasound transducer configured to transmit the high accuracy synchronization signal 17 as an ultrasound signal. The high accuracy synchronization device processor 30 may be configured to compensate for a propagation speed of the ultrasound signal 17 in air by determining a distance between the high accuracy synchronization transmitter 28, 29 and the high accuracy synchronization receiver 13, 15, 21 and calculating a time delay based at least in part on the distance and air parameters. In various embodiments, the high accuracy synchronization transmitter 28, 29

may comprise a transmitting device 29 having a sonar transmitter configured to transmit the high accuracy synchronization signal 17 as a sonar signal. The high accuracy synchronization device processor 30 may be configured to compensate for a propagation speed of the sonar signal 17 in water by determining a distance between the high accuracy synchronization transmitter 28, 29 and the high accuracy synchronization receiver 13, 15, 21 and calculating a time delay based at least in part on the distance and water parameters.

**[68]** As utilized herein the term “circuitry” refers to physical electronic components (i.e. hardware) and any software and/or firmware (“code”) which may configure the hardware, be executed by the hardware, and or otherwise be associated with the hardware. As used herein, for example, a particular processor and memory may comprise a first “circuit” when executing a first one or more lines of code and may comprise a second “circuit” when executing a second one or more lines of code. As utilized herein, “and/or” means any one or more of the items in the list joined by “and/or”. As an example, “x and/or y” means any element of the three-element set {(x), (y), (x, y)}. As another example, “x, y, and/or z” means any element of the seven-element set {(x), (y), (z), (x, y), (x, z), (y, z), (x, y, z)}. As utilized herein, the term “exemplary” means serving as a non-limiting example, instance, or illustration. As utilized herein, the terms “e.g.,” and “for example” set off lists of one or more non-limiting examples, instances, or illustrations. As utilized herein, circuitry or other components are “operable” or “configured” to perform a function whenever the circuitry or component comprises the necessary hardware, code (if any is necessary), and/or other structure to perform the function, regardless of whether performance of the function is disabled, or not enabled, by some user-configurable setting.

**[69]** Other embodiments may provide a computer readable device and/or a non-transitory computer readable medium, and/or a machine readable device and/or a non-transitory machine readable medium, having stored thereon, a machine code and/or a computer program having at least one code section executable by a machine and/or a computer, thereby causing the machine and/or

computer to perform the steps as described herein for synchronizing electronic timing devices in a wireless timing system.

**[70]** Accordingly, aspects of the present disclosure may be realized in hardware, software, or a combination of hardware and software. Certain embodiments may be realized in a centralized fashion in at least one computer system, or in a distributed fashion where different elements are spread across several interconnected computer systems. Any kind of computer system or other apparatus adapted for carrying out the methods described herein is suited. A typical combination of hardware and software may be a general-purpose computer system with a computer program that, when being loaded and executed, controls the computer system such that it carries out the methods described herein.

**[71]** Various embodiments may also be embedded in a computer program product, which comprises all the features enabling the implementation of the methods described herein, and which when loaded in a computer system is able to carry out these methods. Computer program in the present context means any expression, in any language, code or notation, of a set of instructions intended to cause a system having an information processing capability to perform a particular function either directly or after either or both of the following: a) conversion to another language, code or notation; b) reproduction in a different material form.

**[72]** Although devices, methods, and systems according to the present disclosure may have been described in connection with a preferred embodiment, it is not intended to be limited to the specific form set forth herein, but on the contrary, it is intended to cover such alternative, modifications, and equivalents, as can be reasonably included within the scope of the various embodiments as defined by this disclosure and appended diagrams.

**[73]** While the present disclosure has been described with reference to certain embodiments, it will be understood by those skilled in the art that various changes may be made and equivalents may be substituted without departing

from the scope of the present disclosure. In addition, many modifications may be made to adapt a particular situation or material to the teachings of the present disclosure without departing from its scope. Therefore, it is intended that the present disclosure not be limited to the particular embodiment disclosed, but that the present disclosure will include all embodiments falling within the scope of the appended claims.

## CLAIMS

What is claimed is:

1. A system comprising:

at least one timing device comprising:

a timing device communication component configured to transmit and receive information over a wireless network;

a high accuracy synchronization receiver, independent of the timing device communication component, configured to periodically receive a high accuracy synchronization signal; and

a timing device processor comprising a local counter controlled by a local oscillator, the timing device processor communicatively coupled to the timing device communication component, the high accuracy synchronization receiver, and at least one timing component, the timing device processor configured to:

receive the high accuracy synchronization signal from the high accuracy synchronization receiver; and

process the high accuracy synchronization signal to set the local counter to a defined value.

2. The system of claim 1, wherein the timing device processor is configured to:

receive a timing signal from the at least one timing component;

generate a timestamp having a current value of the local counter associated with a time the timing signal is received;

create a timing event comprising the timestamp and a signature associated with one or both of the timing device and the at least one timing component; and

communicate the timing event via the timing device communication component.

3. The system of claim 2, wherein the at least one timing component is a plurality of timing components, and wherein the timing device processor is configured to create the timing event based on the timestamp generated in response to the timing signal received from any of the plurality of timing components.

4. The system of claim 1, wherein the high accuracy synchronization receiver comprises a receiver structure corresponding to a type of the high accuracy synchronization signal being periodically received.

5. The system of claim 4, wherein the type of the high accuracy synchronization signal is one of:

infrared light;

visible light;

ultraviolet light; or

laser light.

6. The system of claim 4, wherein the type of the high accuracy synchronization signal is a radio signal.

7. The system of claim 6, wherein the radio signal is provided in an industrial, scientific, and medical (ISM) band.

8. The system of claim 4, wherein the type of the high accuracy synchronization signal is an ultrasound signal.

9. The system of claim 4, wherein the type of the high accuracy synchronization signal is a sonar signal.

10. The system of claim 1, wherein the timing device processor is configured to communicate a wireless signal via the timing device communication component to confirm receipt of the high accuracy synchronization signal.

11. The system of claim 1, wherein:

the high accuracy synchronization receiver is configured to periodically receive the high accuracy synchronization signal of a first type; and

the at least one timing device comprises an additional high accuracy synchronization receiver, independent of the timing device communication component, configured to periodically receive an additional high accuracy synchronization signal of a second type that is different from the first type.

12. The system of claim 1, comprising a plurality of the at least one timing device.

13. The system of claim 1, comprising a high accuracy synchronization device comprising:

a high accuracy synchronization device communication component configured to transmit and receive information over the wireless network;

a high accuracy synchronization transmitter, independent of the high accuracy synchronization device communication component, configured to periodically transmit the high accuracy synchronization signal; and

a high accuracy synchronization device processor comprising a master counter controlled by a high accuracy oscillator, the high accuracy synchronization device processor communicatively coupled to the a high accuracy synchronization device communication component and the high accuracy synchronization transmitter, the high accuracy synchronization device processor configured to:

calculate a time interval based at least in part on one or both of a relative drift and an absolute drift of the local oscillator of the at least one timing device; and

trigger the high accuracy synchronization transmitter to transmit the high accuracy synchronization signal when the time interval has elapsed.

14. The system of claim 13, wherein the time interval is defined based at least in part on a desired tick resolution.

15. The system of claim 14, wherein the desired tick resolution is 250 microseconds or less.

16. The system of claim 14, wherein the time interval is defined to provide over-synchronization such that a plurality of high accuracy synchronization signals are transmitted by the high accuracy synchronization transmitter prior to a maximum time interval for achieving the desired tick resolution.

17. The system of claim 13, wherein each of the timing device communication component and the high accuracy synchronization device communication component comprises a transceiver and an antenna.

18. The system of claim 13, wherein the high accuracy synchronization device is one of integrated with or communicatively coupled to a start system.

19. The system of claim 13, wherein the high accuracy oscillator has a higher accuracy than the local oscillator of the at least one timing device.

20. The system of claim 13, wherein the high accuracy synchronization transmitter comprises a transmitting device having an infrared diode with an optical lens.

21. The system of claim 13, wherein:

the high accuracy synchronization transmitter comprises a transmitting device having an ultrasound transducer configured to transmit the high accuracy synchronization signal as an ultrasound signal; and

the high accuracy synchronization device processor is configured to compensate for a propagation speed of the ultrasound signal in air by determining a distance between the high accuracy synchronization transmitter and the high accuracy synchronization receiver and calculating a time delay based at least in part on the distance and air parameters.

22. The system of claim 13, wherein:

the high accuracy synchronization transmitter comprises a transmitting device having a sonar transmitter configured to transmit the high accuracy synchronization signal as a sonar signal; and

the high accuracy synchronization device processor is configured to compensate for a propagation speed of the sonar signal in water by determining a distance between the high accuracy synchronization transmitter and the high accuracy synchronization receiver and calculating a time delay based at least in part on the distance and water parameters.

23. The system of claim 1, wherein the at least one timing component is one or more of:

a touch pad;

a push button; and

a relay judging platform.

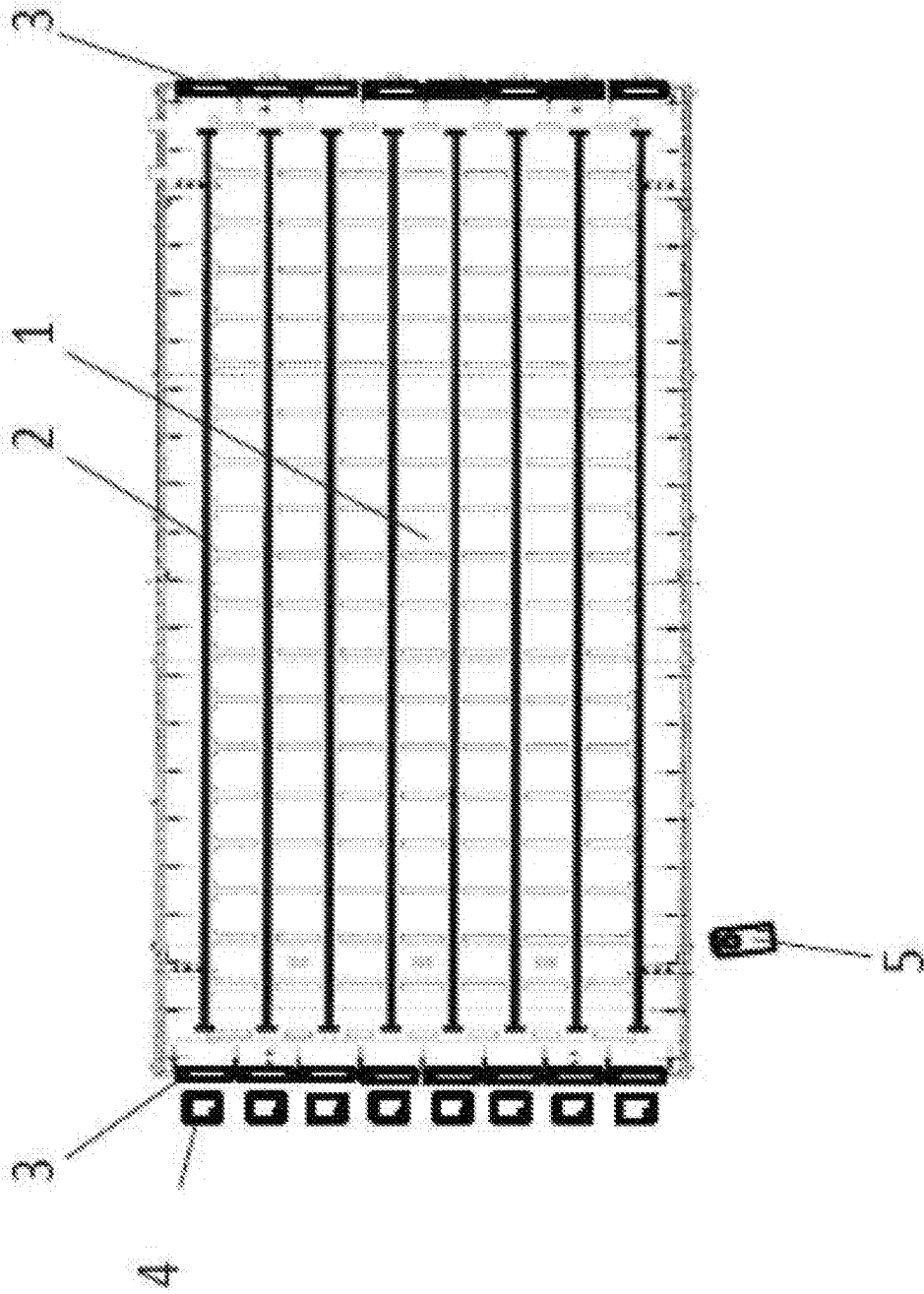

FIG. 1

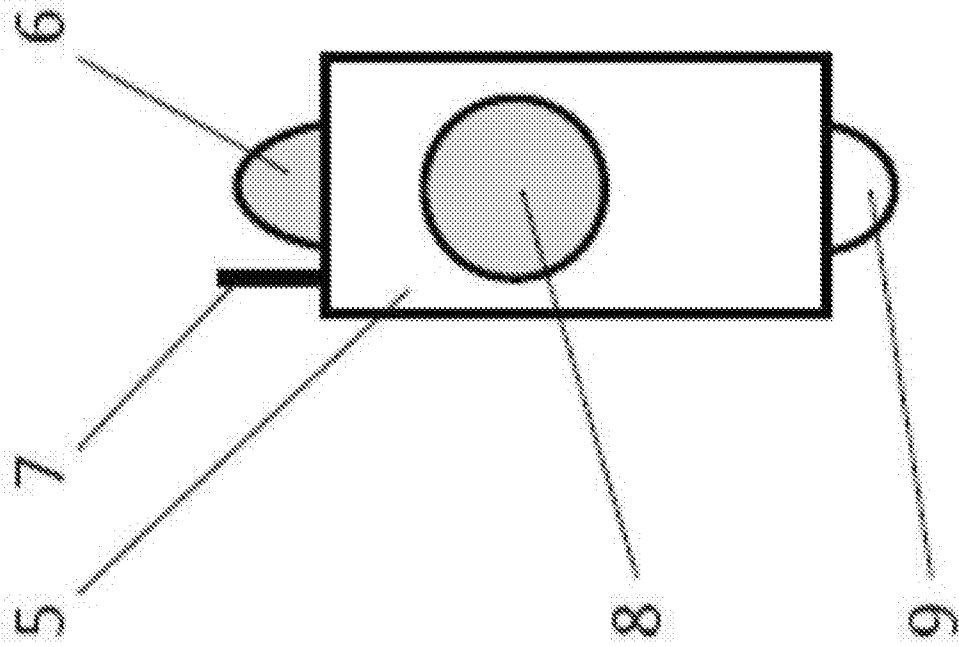

FIG. 2A

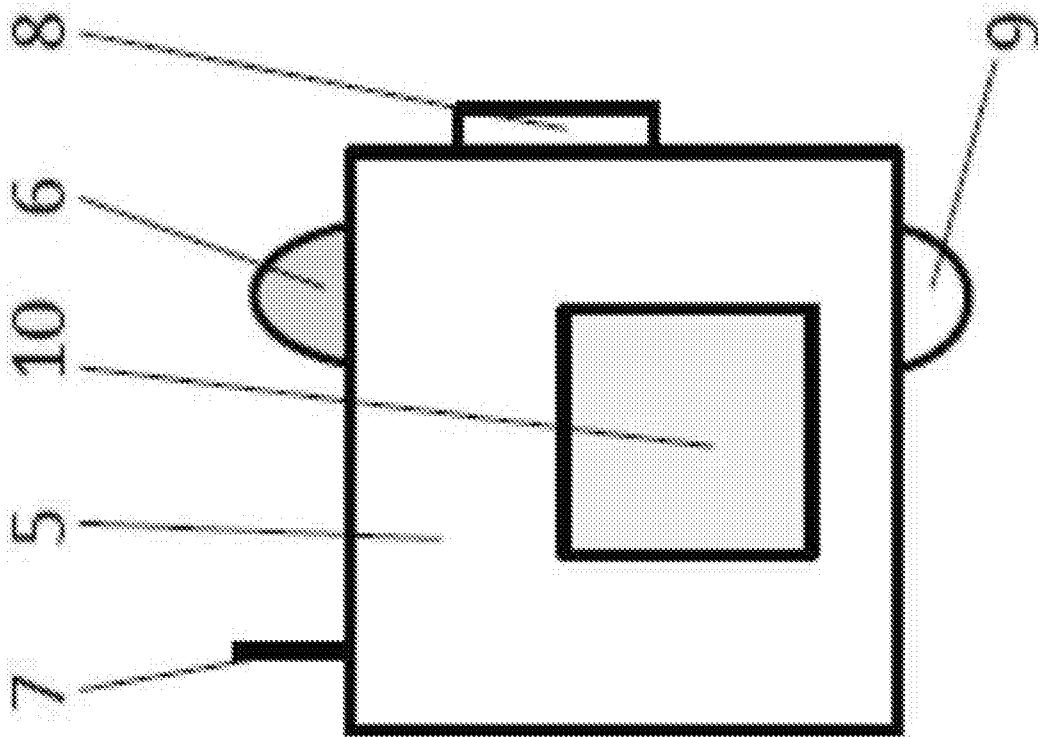

FIG. 2B

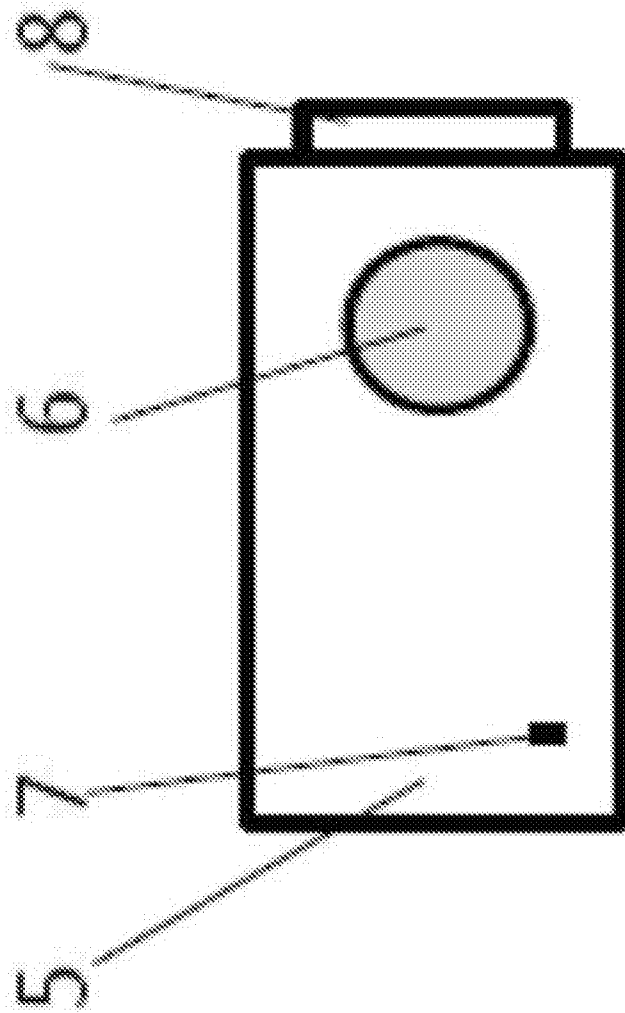

FIG. 2C

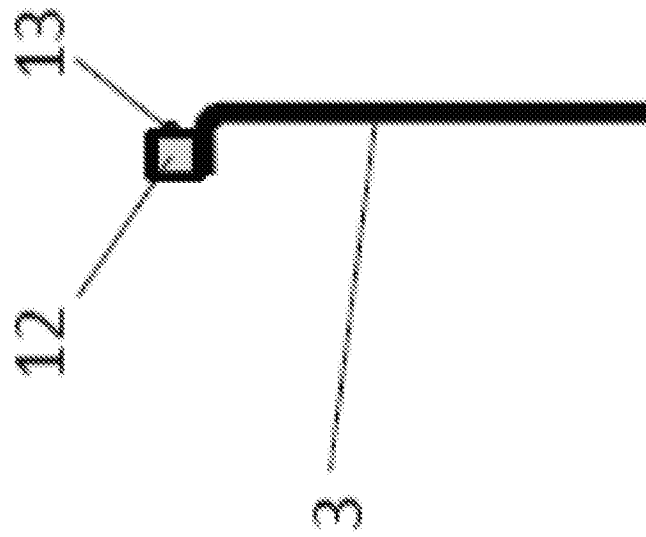

FIG. 3A

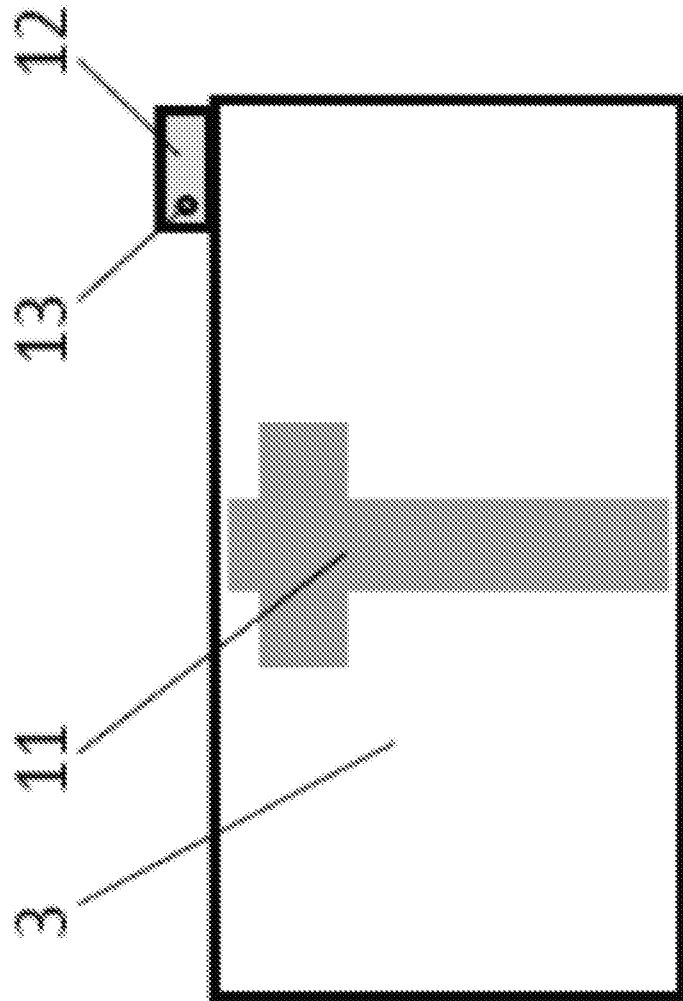

FIG. 3B

7/15

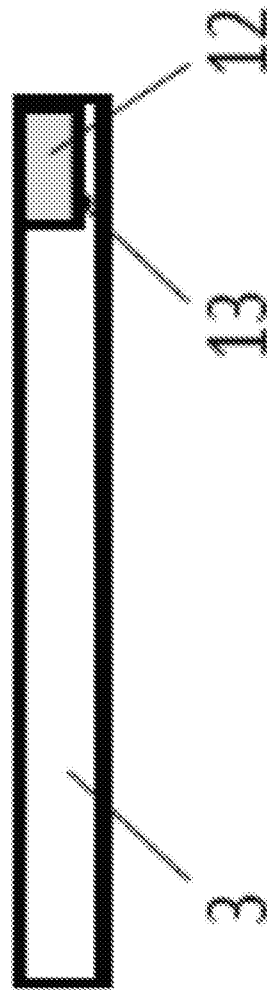

FIG. 3C

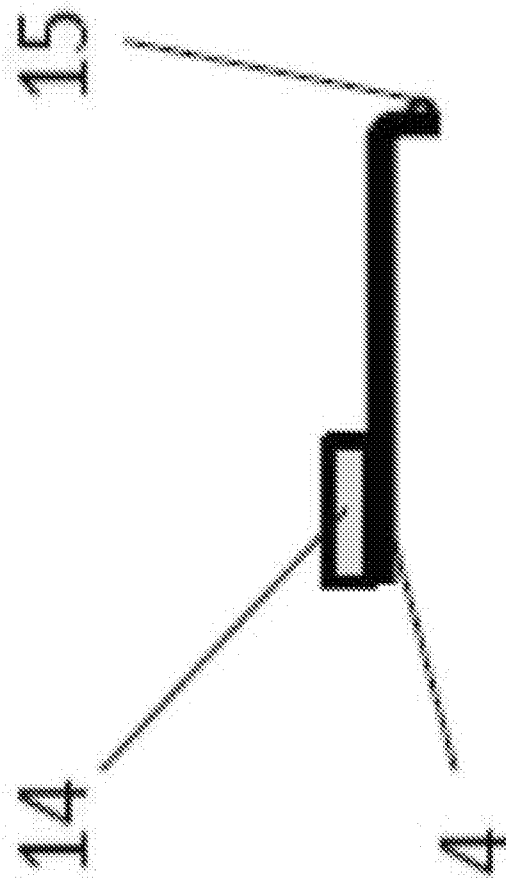

FIG. 4A

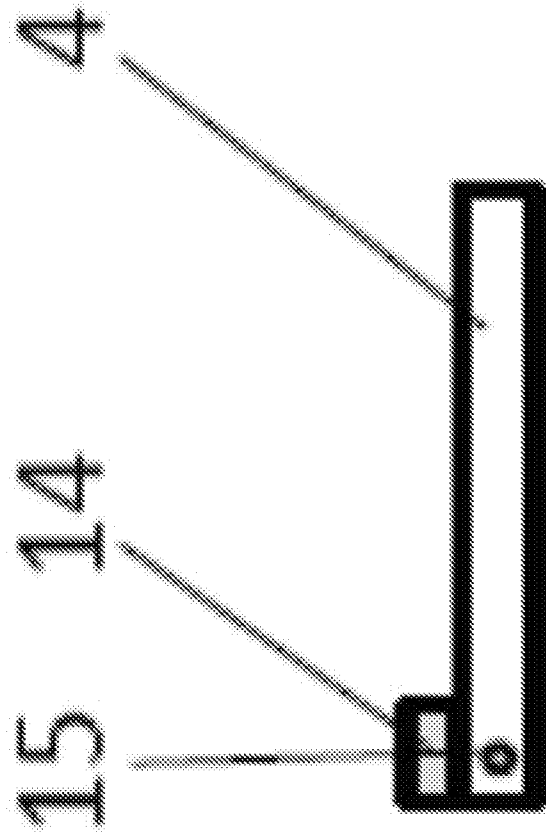

FIG. 4B

10/15

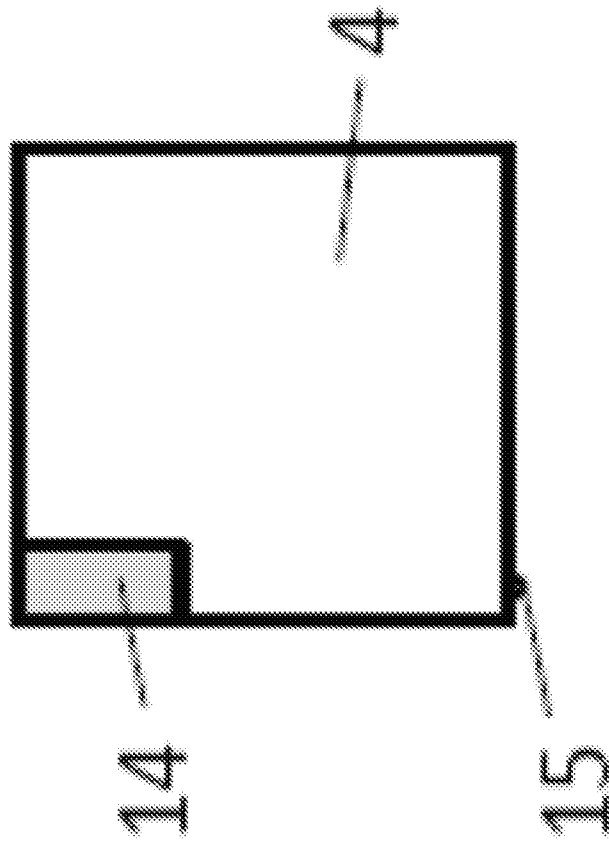

FIG. 4C

11/15

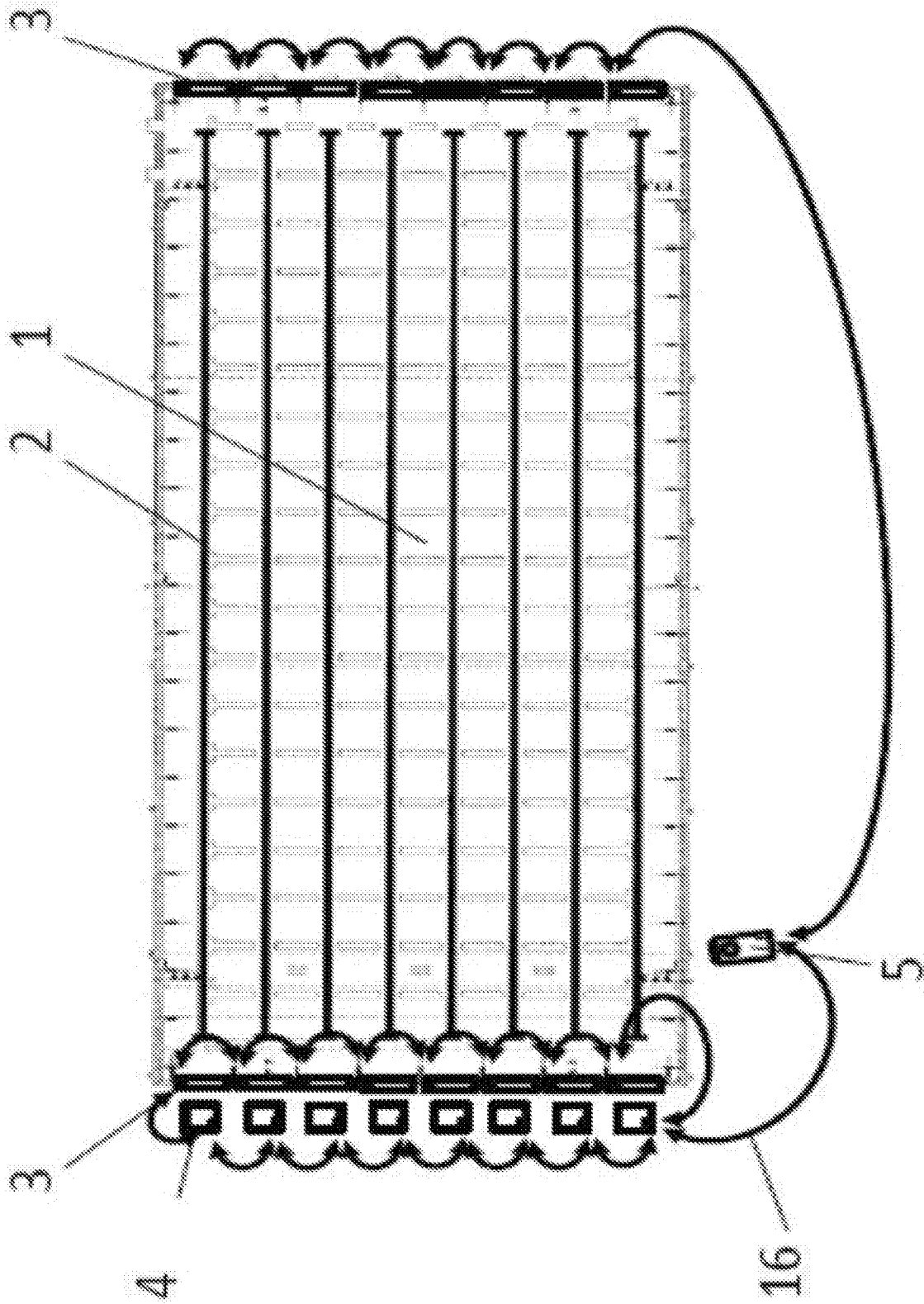

FIG. 5



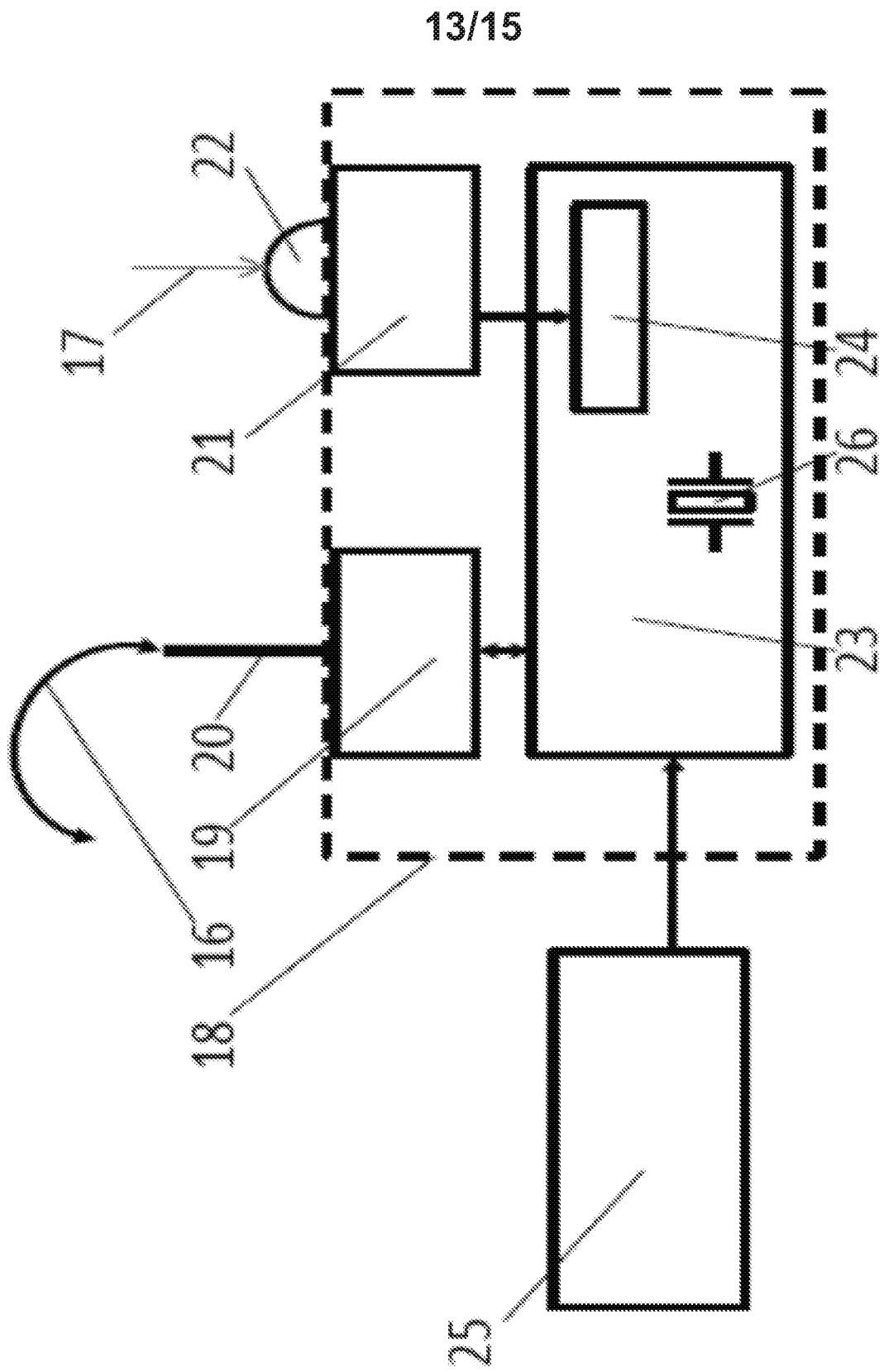

FIG. 7

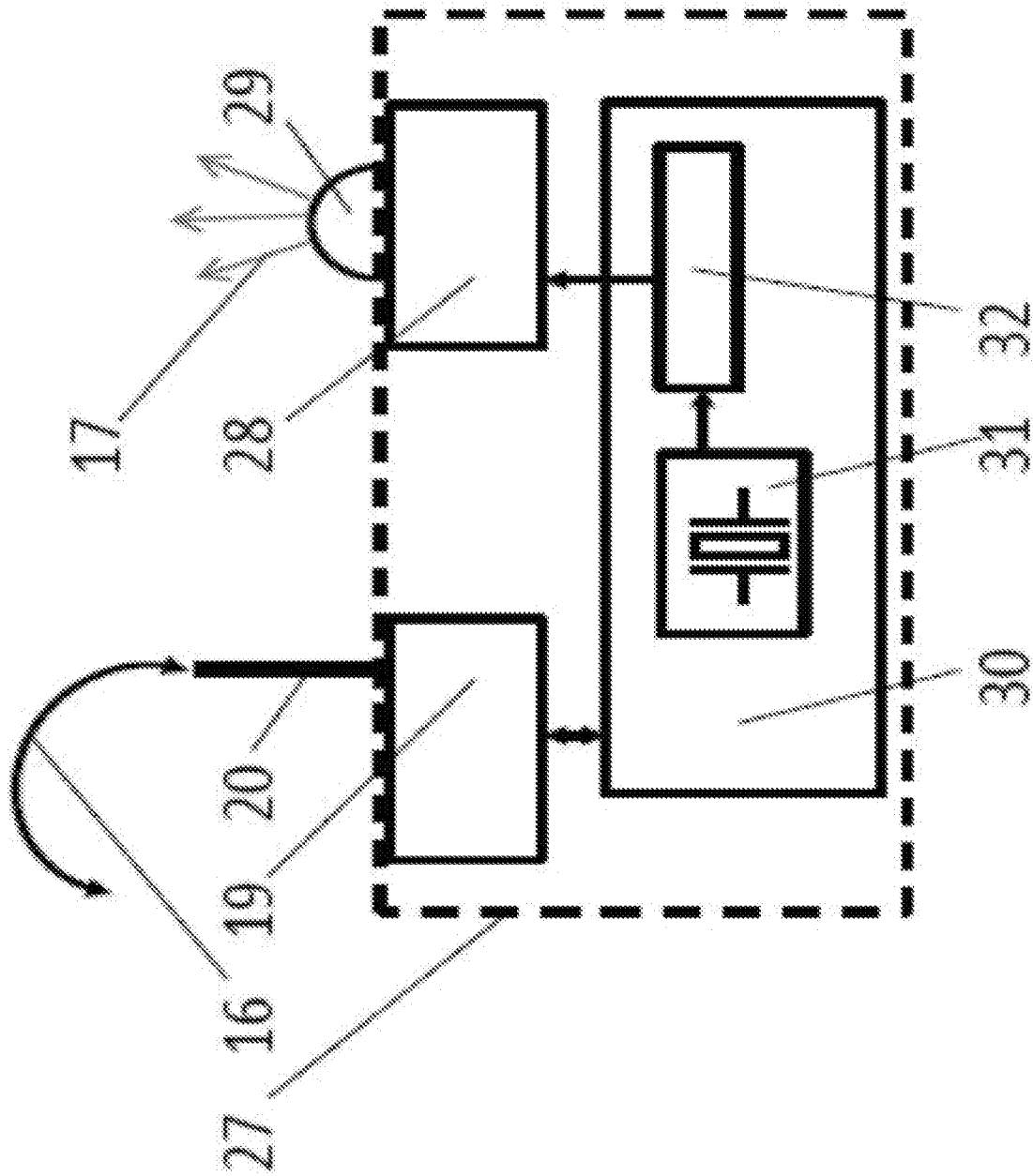

FIG. 8

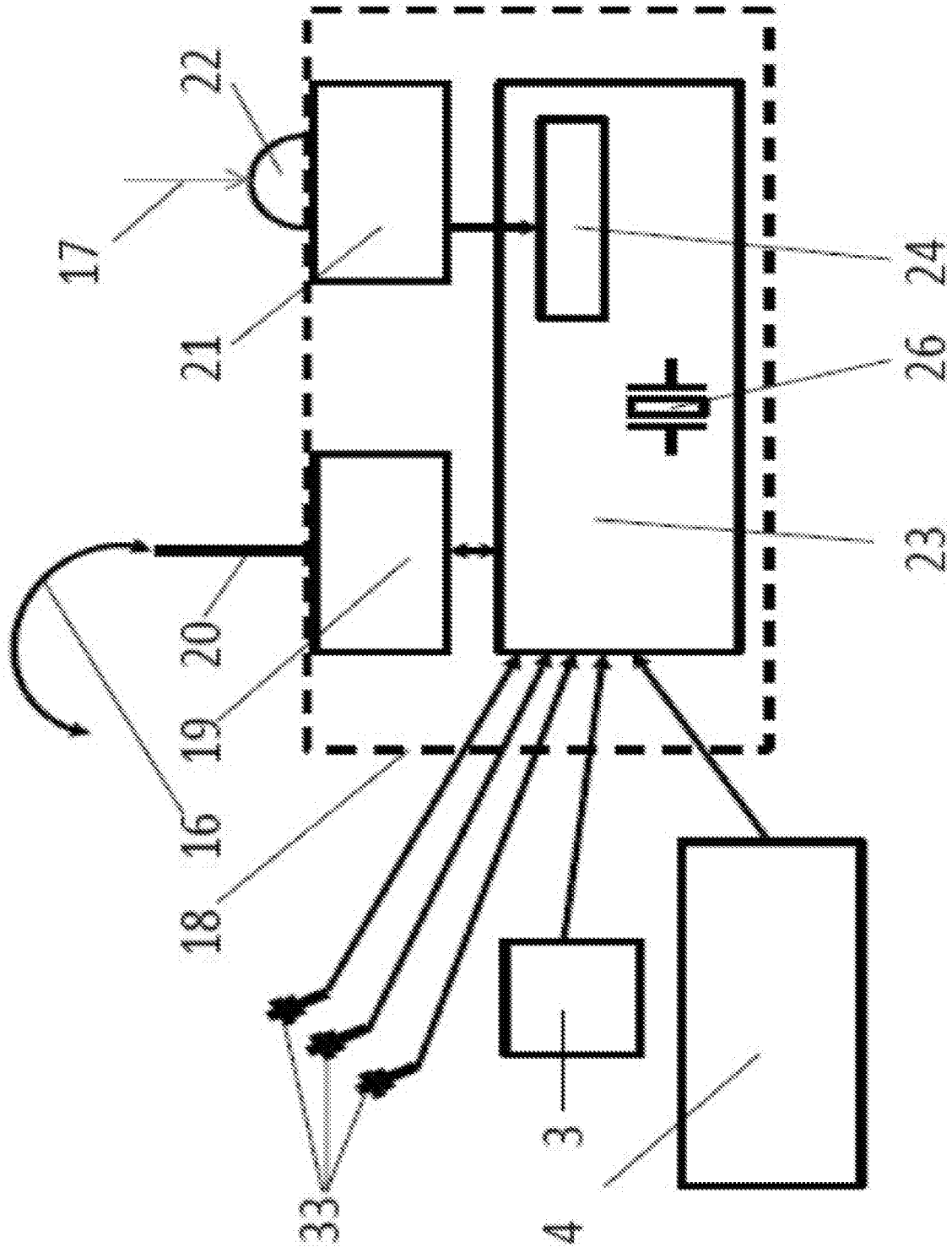

FIG. 9

INTERNATIONAL SEARCH REPORT

International application No.

PCT/US19/15237

A. CLASSIFICATION OF SUBJECT MATTER  
 IPC - G04F 10/02; A63B 71/06; G07C 1/24 (2019.01)  
 CPC - A63B 71/0686; G07C 1/24; G04F 10/02

According to International Patent Classification (IPC) or to both national classification and IPC

B. FIELDS SEARCHED

Minimum documentation searched (classification system followed by classification symbols)  
 See Search History document

Documentation searched other than minimum documentation to the extent that such documents are included in the fields searched  
 See Search History document

Electronic data base consulted during the international search (name of data base and, where practicable, search terms used)  
 See Search History document

C. DOCUMENTS CONSIDERED TO BE RELEVANT

Category*	Citation of document, with indication, where appropriate, of the relevant passages	Relevant to claim No.
A	US 8,384,590 B2 (HUANG, P et al.) 26 February 2013, entire document	1-23
A	US 5,440,313 A (OSTERDOCK, T et al.) 08 August 1995, entire document	1-23
A	EP 1223435 A1 (TOY BUILDERS) 17 July 2002, entire document	1-23
A	JP 2006-30002 A (SEIKO PRECISION) 02 February 2006 (02.02.2006), entire document with translation	1-23
A	JP 11-160466 (ISHIKAWA SHOJI KK) 18 June 1999 (18.06.1999), entire document with translation	1-23
A	US 2012/0025944 A1 (HANSEN) 02 February 2012 (02.02.2012), entire document	1-23

Further documents are listed in the continuation of Box C.

See patent family annex.

\* Special categories of cited documents:  
 "A" document defining the general state of the art which is not considered to be of particular relevance  
 "E" earlier application or patent but published on or after the international filing date  
 "L" document which may throw doubts on priority claim(s) or which is cited to establish the publication date of another citation or other special reason (as specified)  
 "O" document referring to an oral disclosure, use, exhibition or other means  
 "P" document published prior to the international filing date but later than the priority date claimed

"T" later document published after the international filing date or priority date and not in conflict with the application but cited to understand the principle or theory underlying the invention  
 "X" document of particular relevance; the claimed invention cannot be considered novel or cannot be considered to involve an inventive step when the document is taken alone  
 "Y" document of particular relevance; the claimed invention cannot be considered to involve an inventive step when the document is combined with one or more other such documents, such combination being obvious to a person skilled in the art  
 "&" document member of the same patent family

Date of the actual completion of the international search  
 26 March 2019 (26.03.2019)

Date of mailing of the international search report  
**30 APR 2019**

Name and mailing address of the ISA/  
 Mail Stop PCT, Attn: ISA/US, Commissioner for Patents  
 P.O. Box 1450, Alexandria, Virginia 22313-1450  
 Facsimile No. 571-273-8300

Authorized officer  
 Shane Thomas  
 PCT Helpdesk: 571-272-4300  
 PCT OSP: 571-272-7774