



US 20130172726A9

(19) **United States**  
(12) **Patent Application Publication**  
**SAADAT et al.**

(10) **Pub. No.: US 2013/0172726 A9**  
(48) **Pub. Date: Jul. 4, 2013**  
**CORRECTED PUBLICATION**

(54) **IN-VIVO VISUALIZATION SYSTEMS**

(75) Inventors: **Vahid SAADAT**, Atherton, CA (US); **Zachary J. MALCHANO**, San Francisco, CA (US); **Jason Paul WATSON**, San Jose, CA (US); **Antony Jonathan FIELDS**, San Francisco, CA (US); **Chris A. ROTHE**, San Mateo, CA (US); **Bryan WYLIE**, San Jose, CA (US); **Veerappan SWAMINATHAN**, Sunnyvale, CA (US)

(60) Provisional application No. 61/177,618, filed on May 12, 2009, provisional application No. 60/804,801, filed on Jun. 14, 2006, provisional application No. 60/806,924, filed on Jul. 10, 2006, provisional application No. 60/806,926, filed on Jul. 10, 2006, provisional application No. 60/871,415, filed on Dec. 21, 2006, provisional application No. 60/871,424, filed on Dec. 21, 2006, provisional application No. 60/888,242, filed on Feb. 5, 2007.

**Publication Classification**

(73) Assignee: **Voyage Medical, Inc.**, Redwood City, CA (US)

(51) **Int. Cl.**  
**A61B 5/05** (2006.01)

(21) Appl. No.: **12/778,878**

(52) **U.S. Cl.**  
USPC ..... **600/407**

(22) Filed: **May 12, 2010**

**Prior Publication Data**

(57) **ABSTRACT**

(15) Correction of US 2010/0292558 A1 Nov. 18, 2010  
See (63) and (60) Related U.S. Application Data.

In vivo visualization systems are described which facilitate tissue treatment by a user in utilizing real time visualized tissue images with generated three-dimensional models of the tissue region of interest, such as the left atrial chamber of a subject's heart. Directional indicators on the visualized tissue as well as the imaging systems may be utilized while other variations may utilize image rotation or manipulation of visualized tissue regions to facilitate catheter control. Moreover, visualized tissue regions may be combined with imaged tissue regions as well as navigational information to further facilitate tissue treatments.

(65) US 2010/0292558 A1 Nov. 18, 2010

**Related U.S. Application Data**

(63) Continuation-in-part of application No. 11/763,399, filed on Jun. 14, 2007.

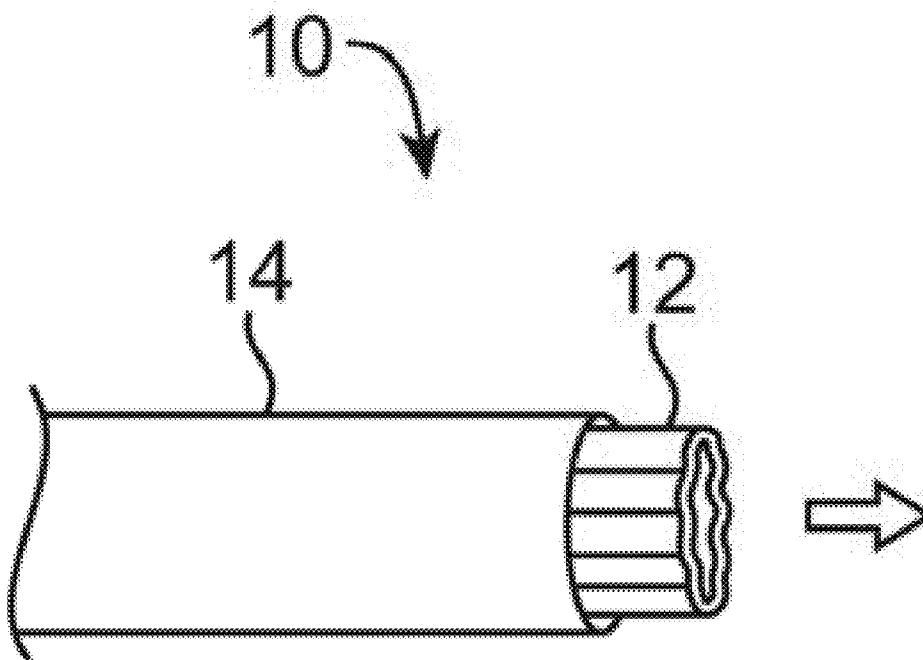

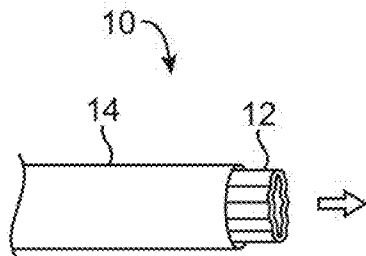

FIG. 1A

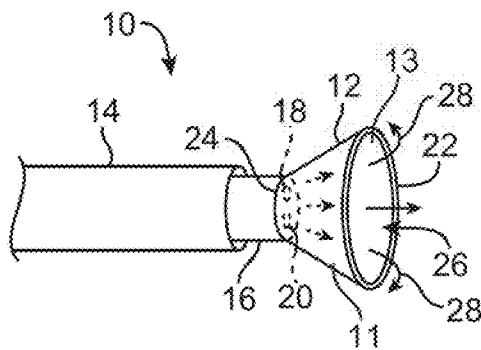

FIG. 1B

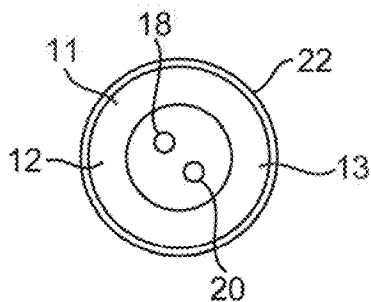

FIG. 1C

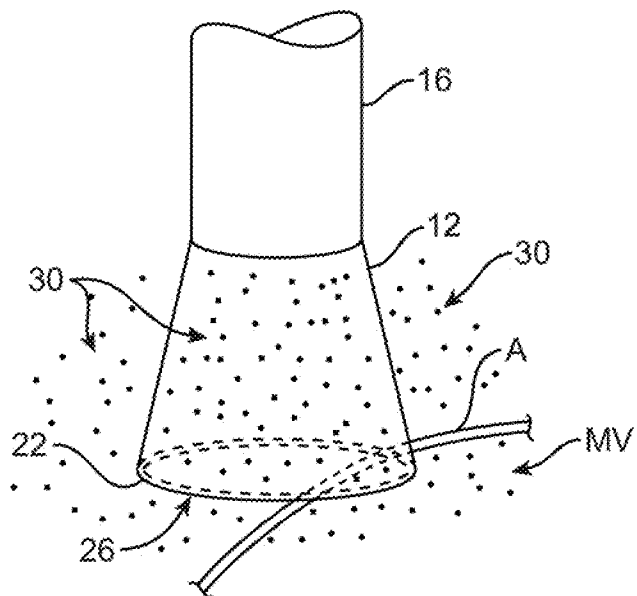

FIG. 2A

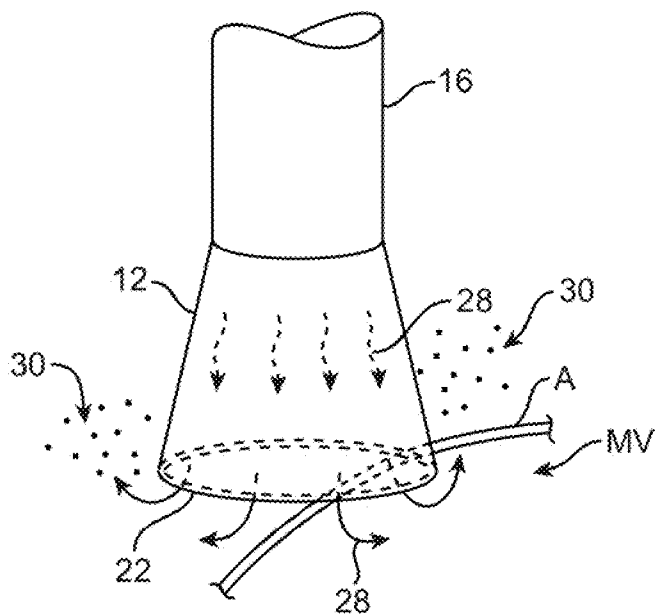

FIG. 2B

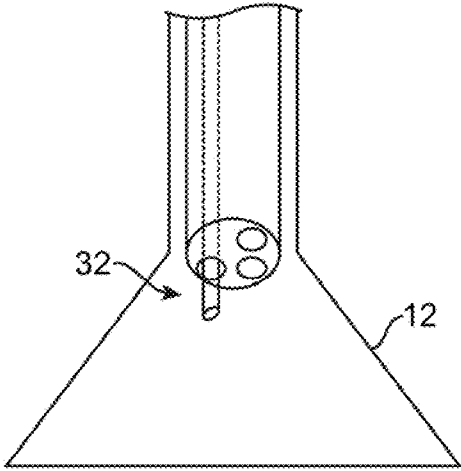

FIG. 3A

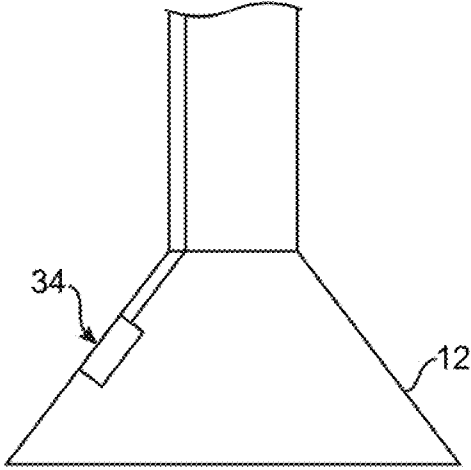

FIG. 3B

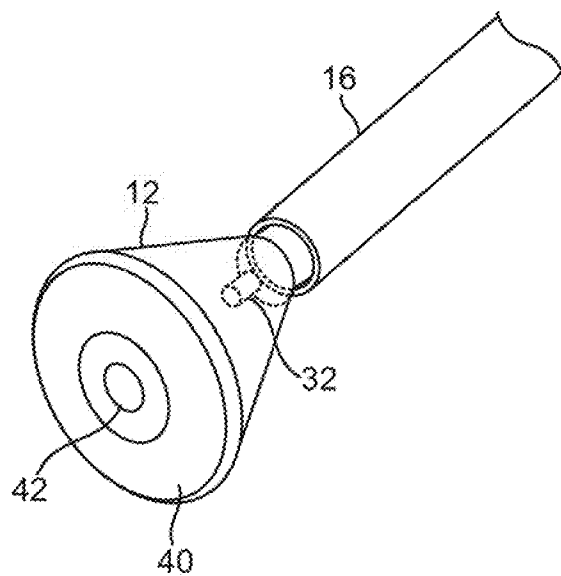

FIG. 4A

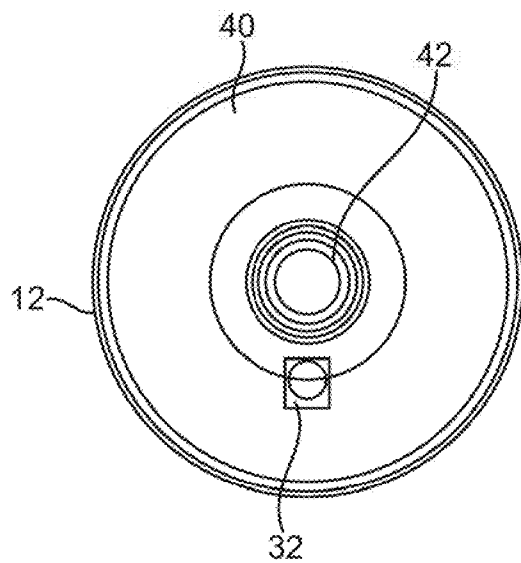

FIG. 4B

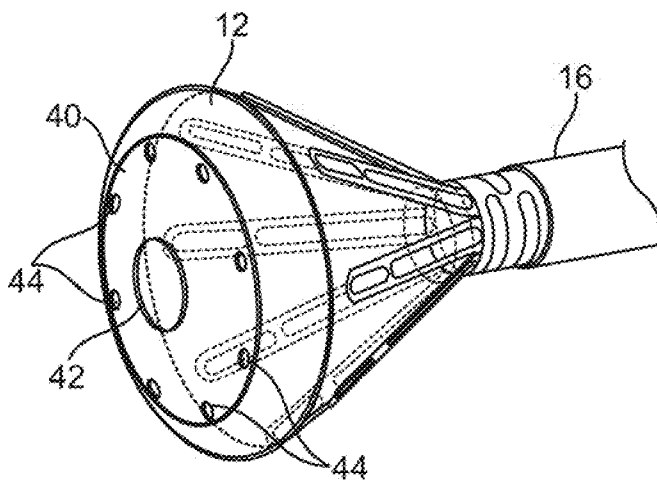

FIG. 5A

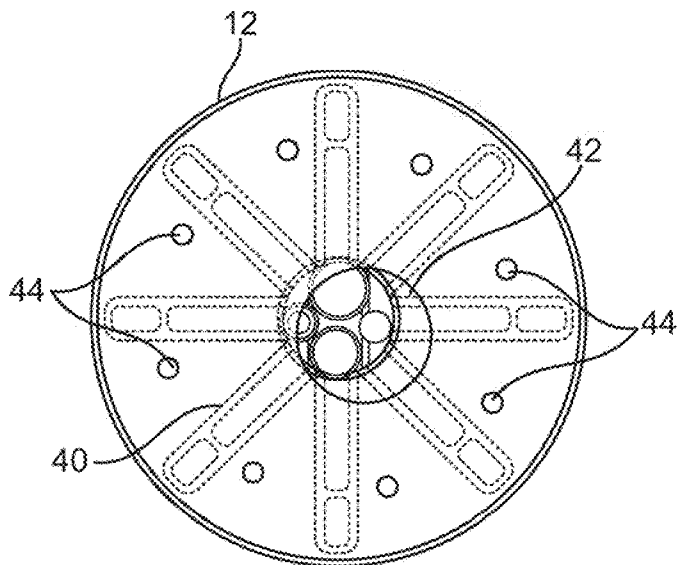
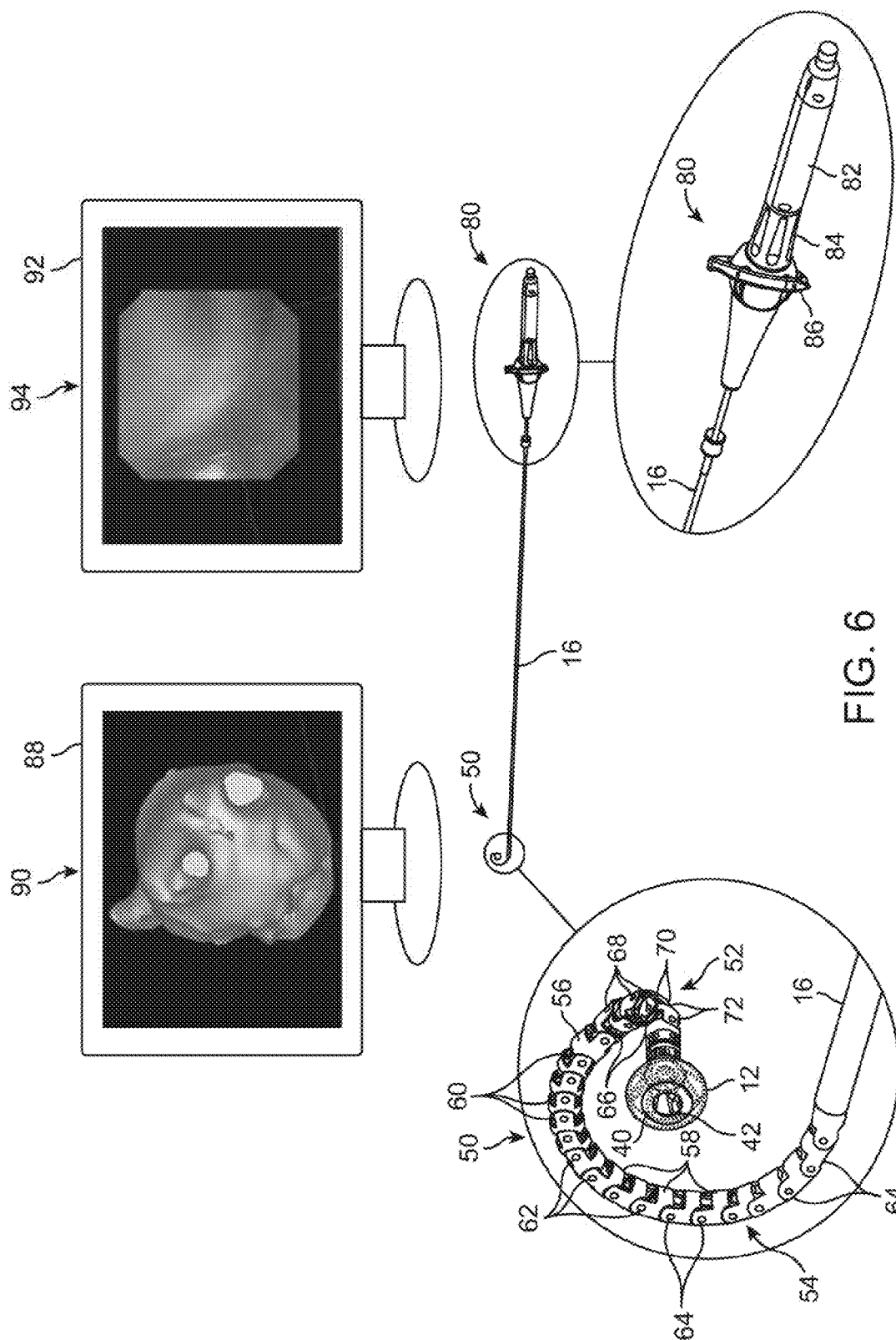

FIG. 5B



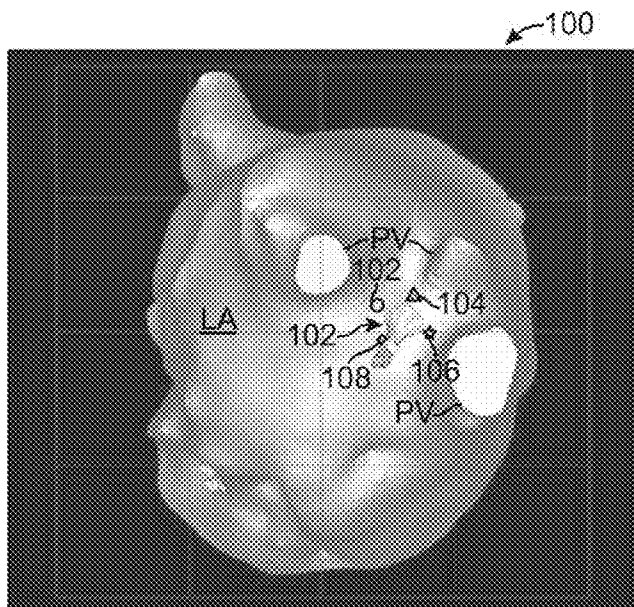

FIG. 7A

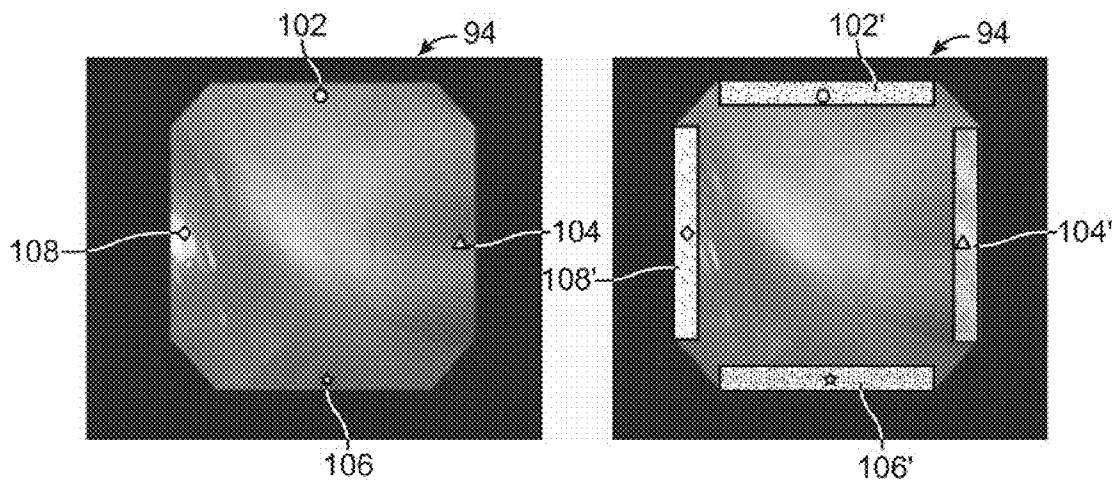

FIG. 7B

FIG. 7C



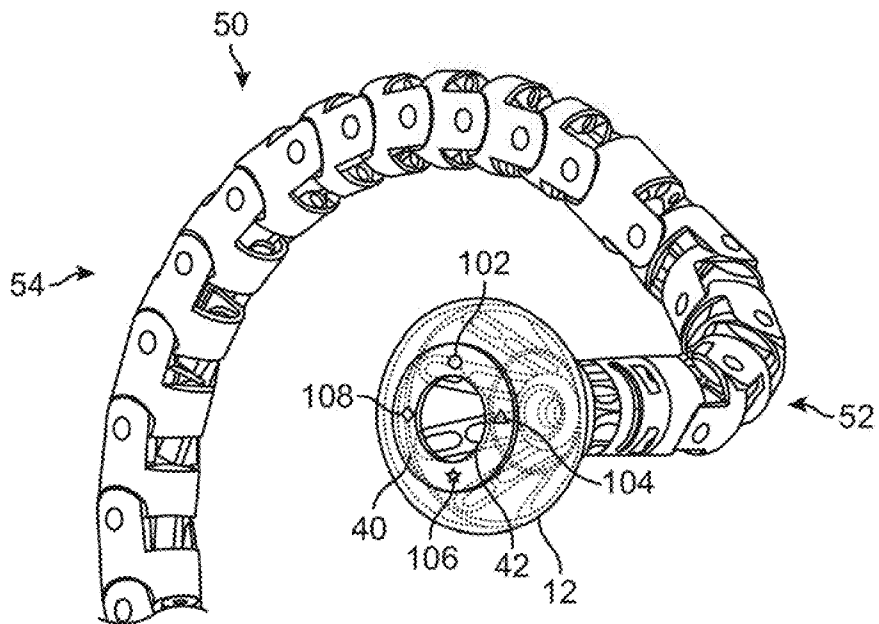

FIG. 8A

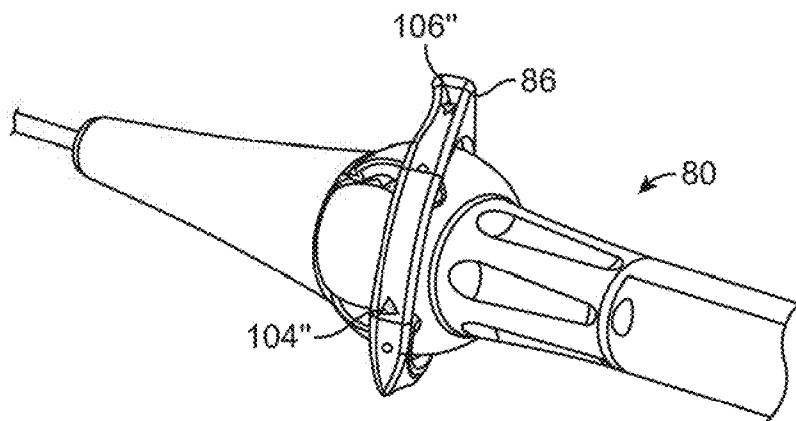

FIG. 8B

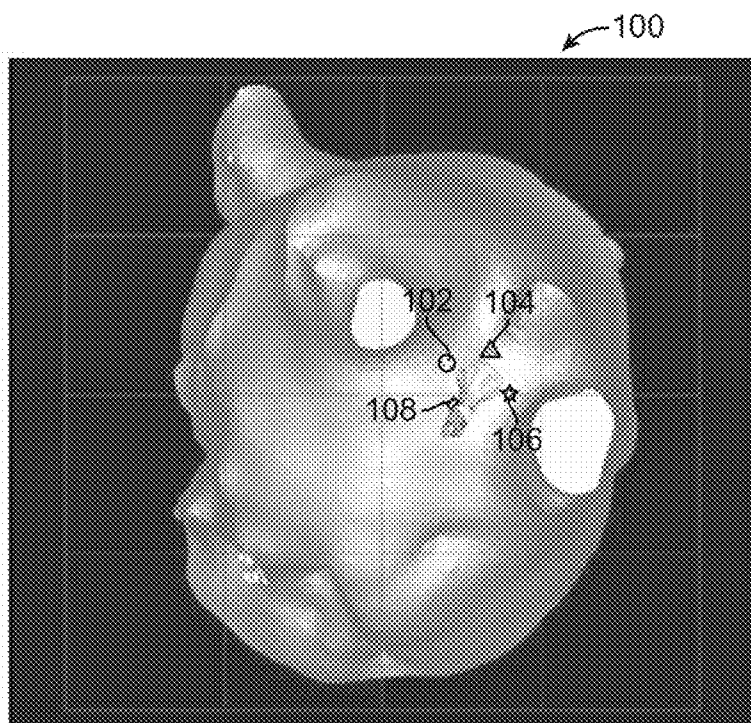

FIG. 9A

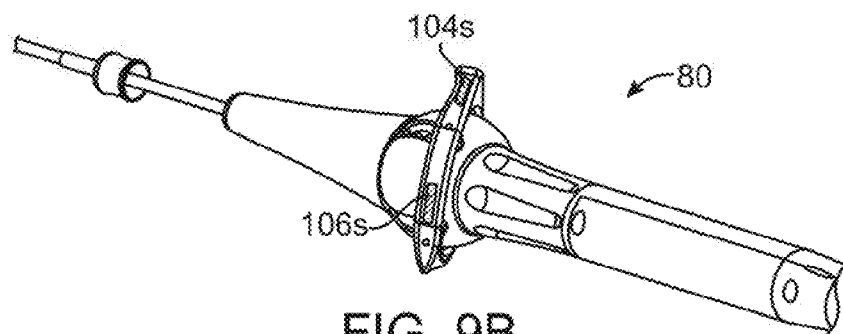

FIG. 9B

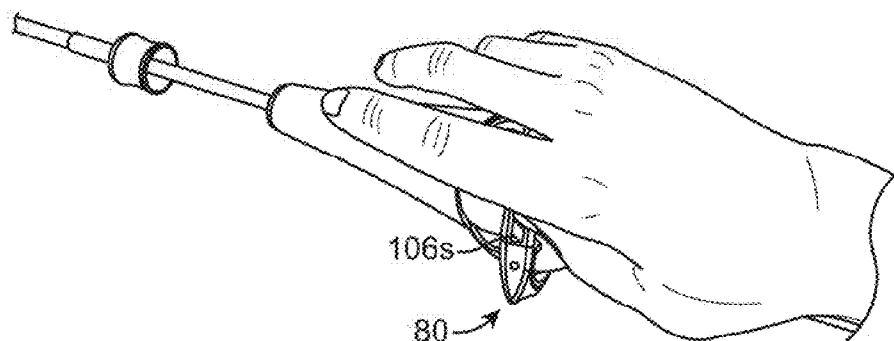

FIG. 9C

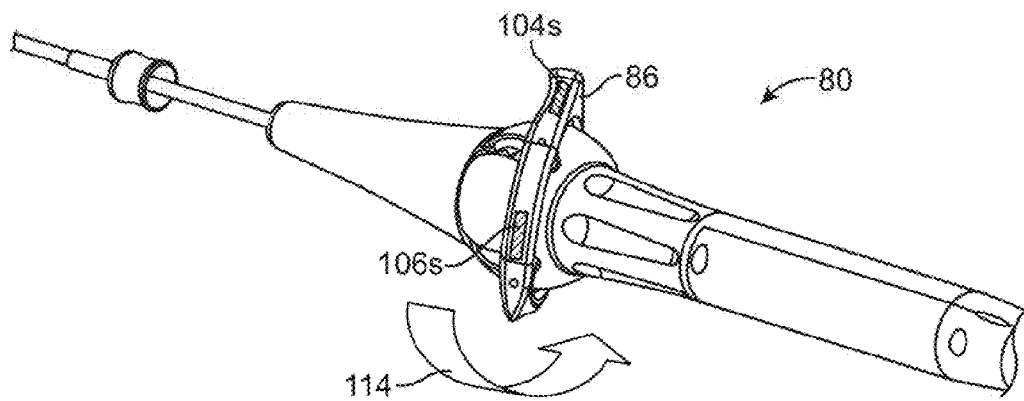

FIG. 10A

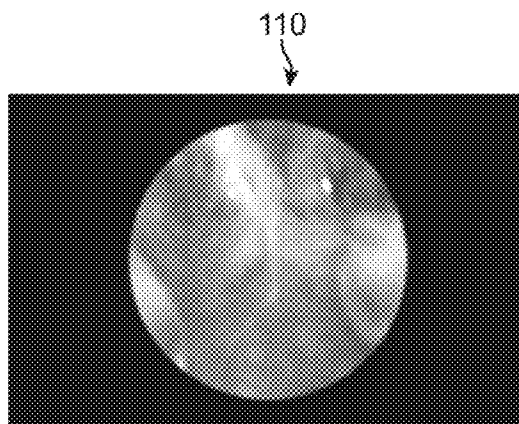

FIG. 10B

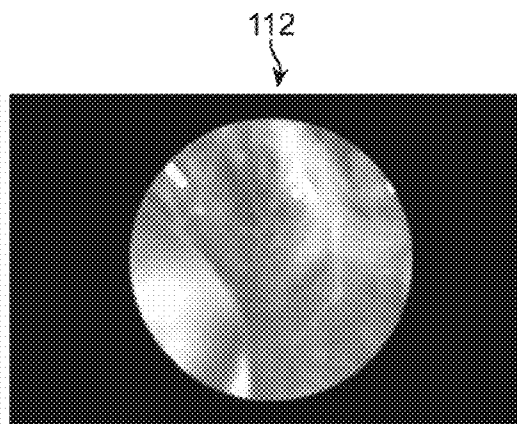

FIG. 10C

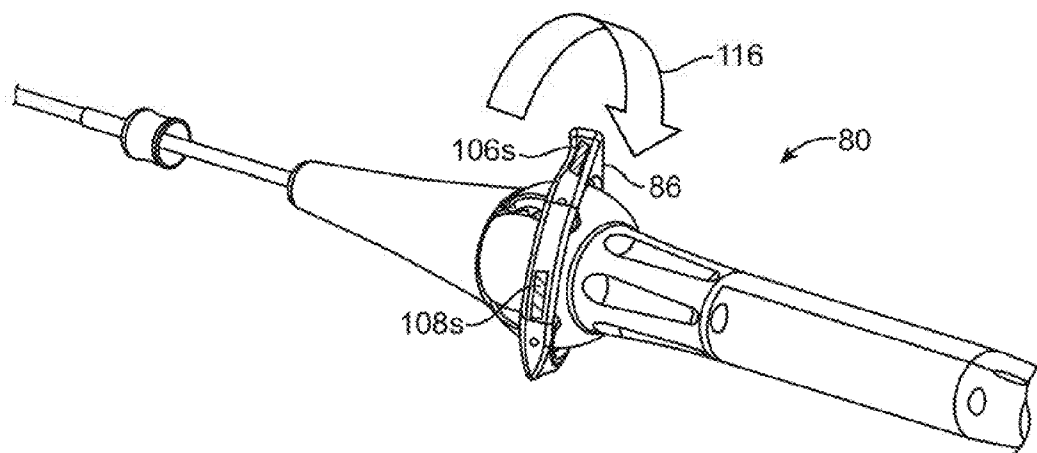

FIG. 11A

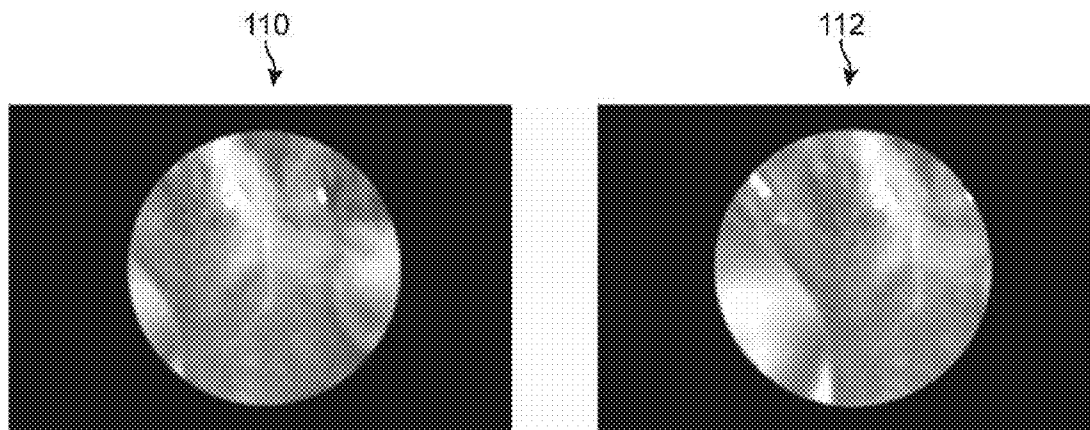

FIG. 11B

FIG. 11C

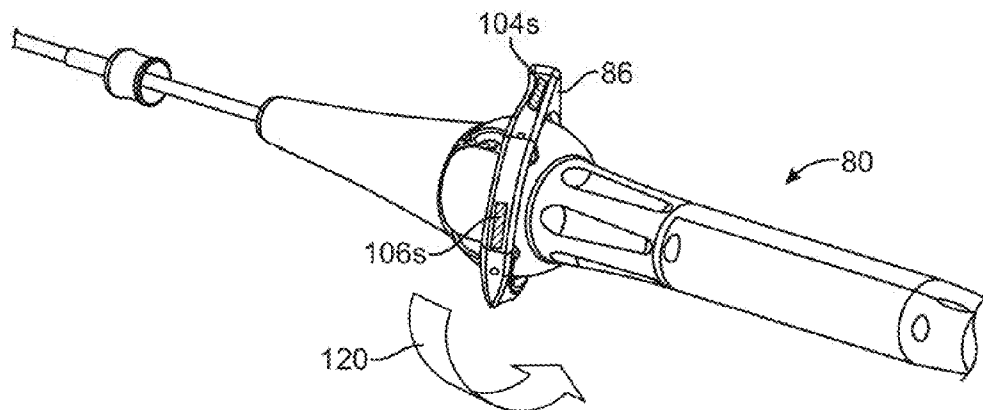

FIG. 12A

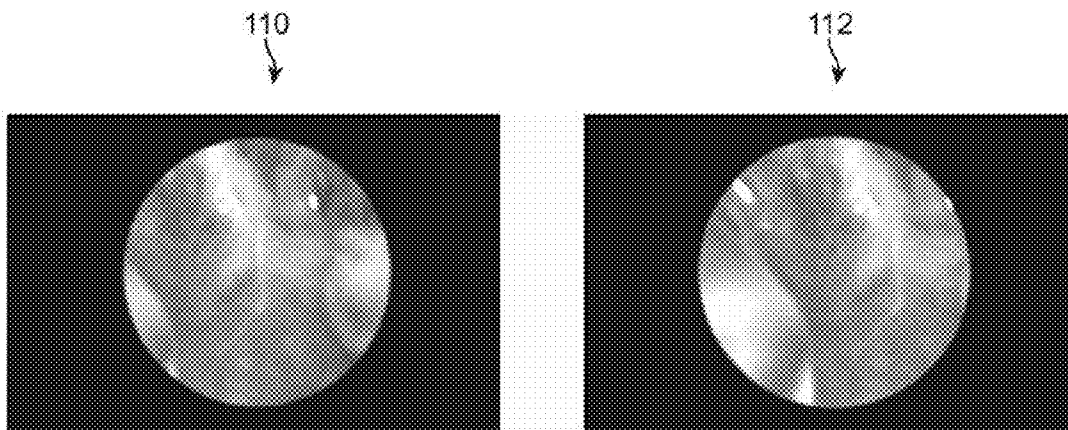

FIG. 12B

FIG. 12C

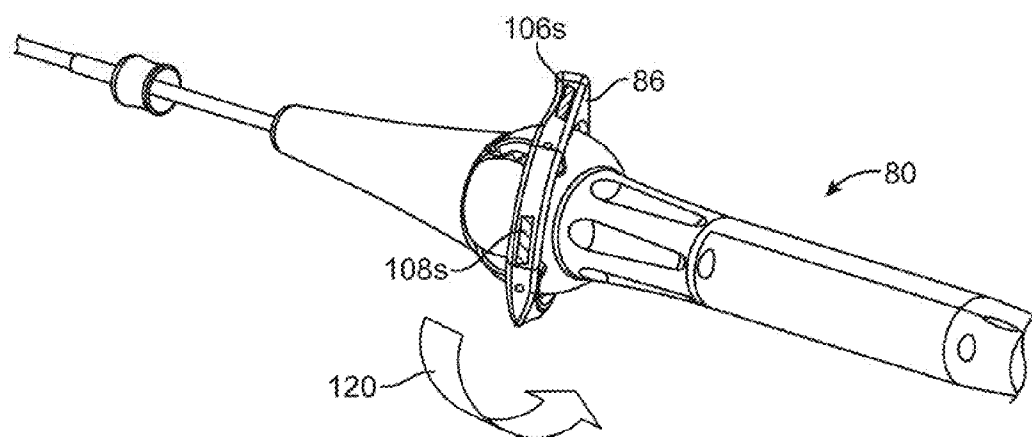

FIG. 13A

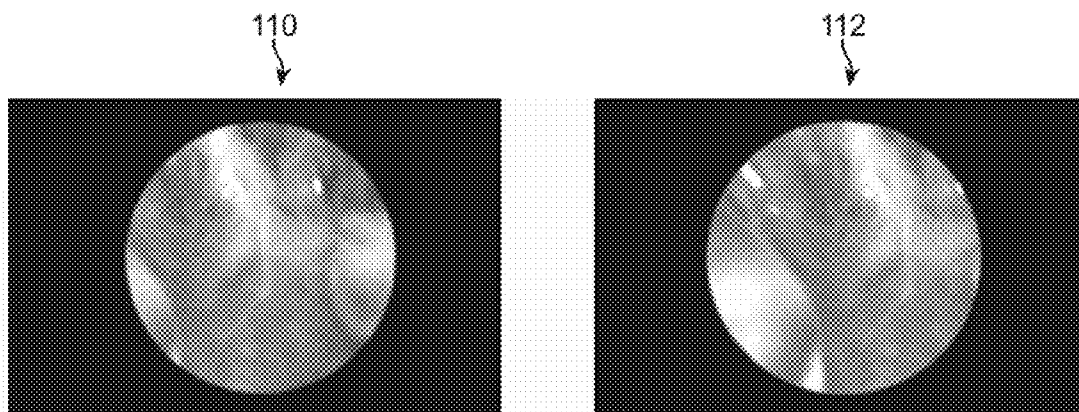

FIG. 13B

FIG. 13C

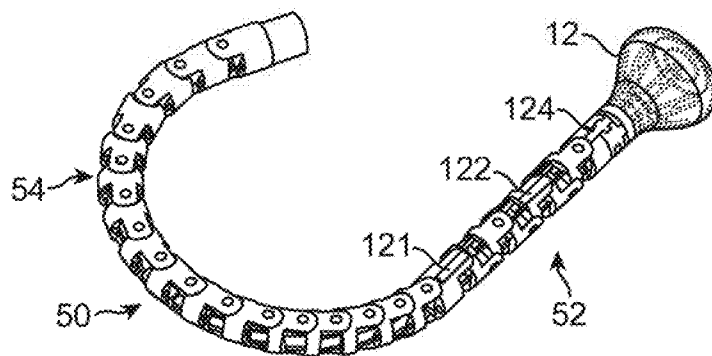

FIG. 14A

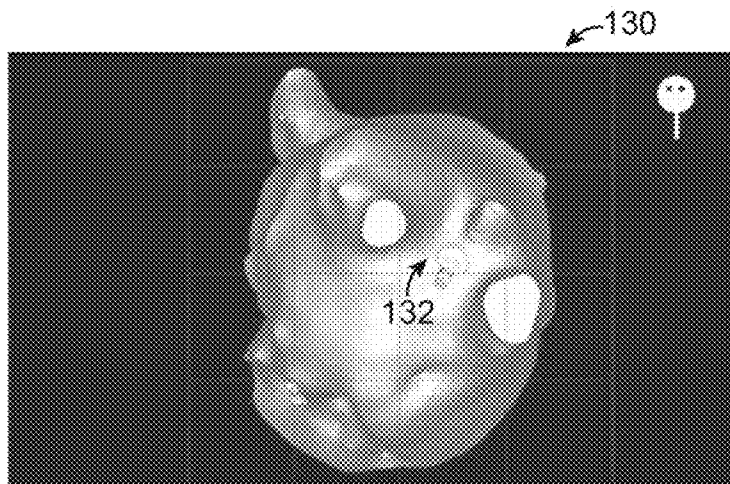

FIG. 14B

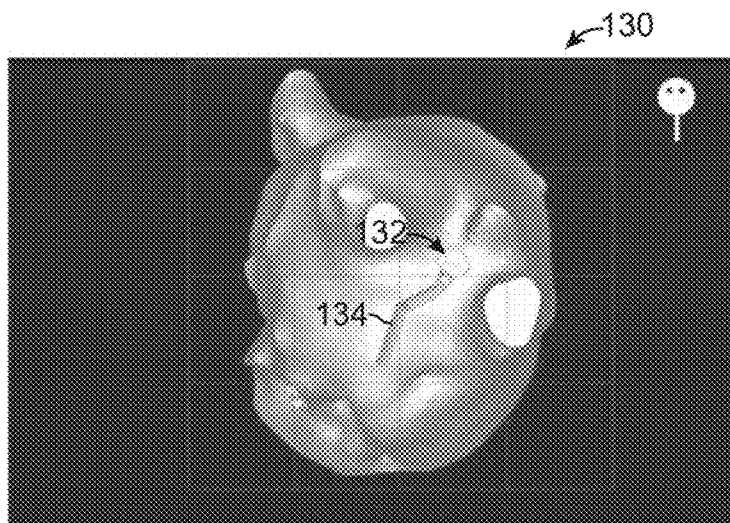

FIG. 14C

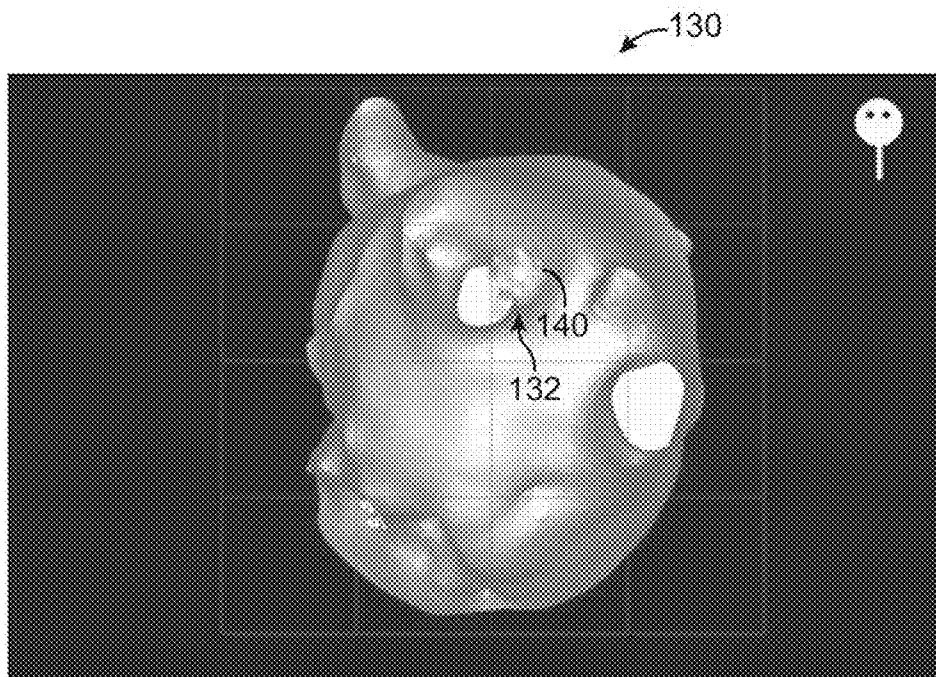

FIG. 15A

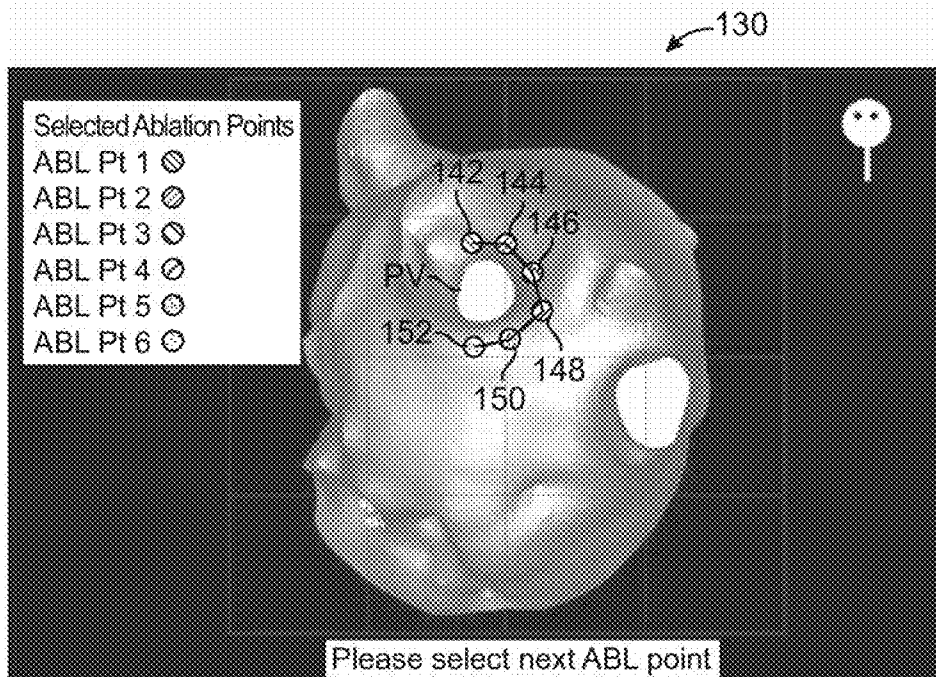

FIG. 15B



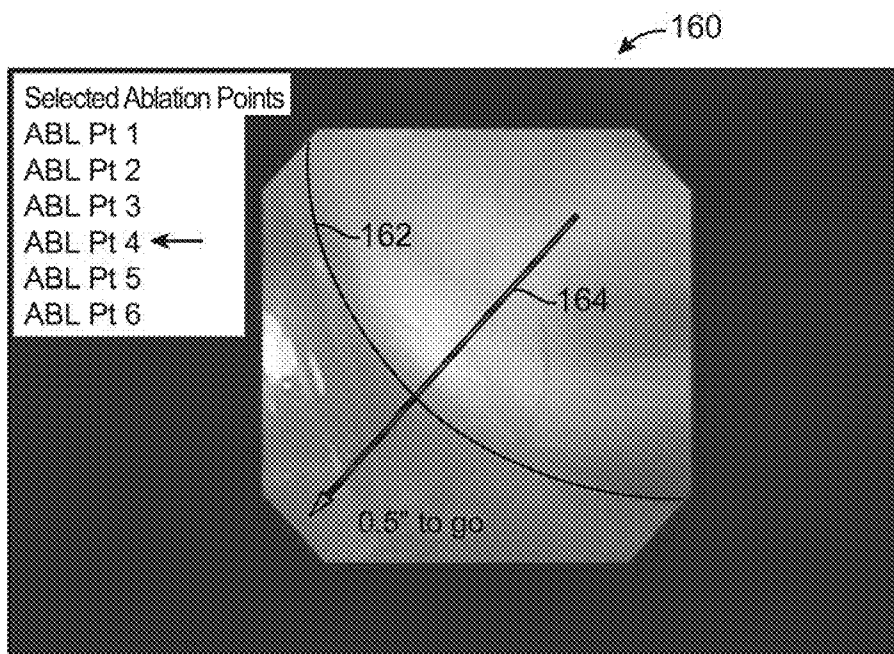

FIG. 16A

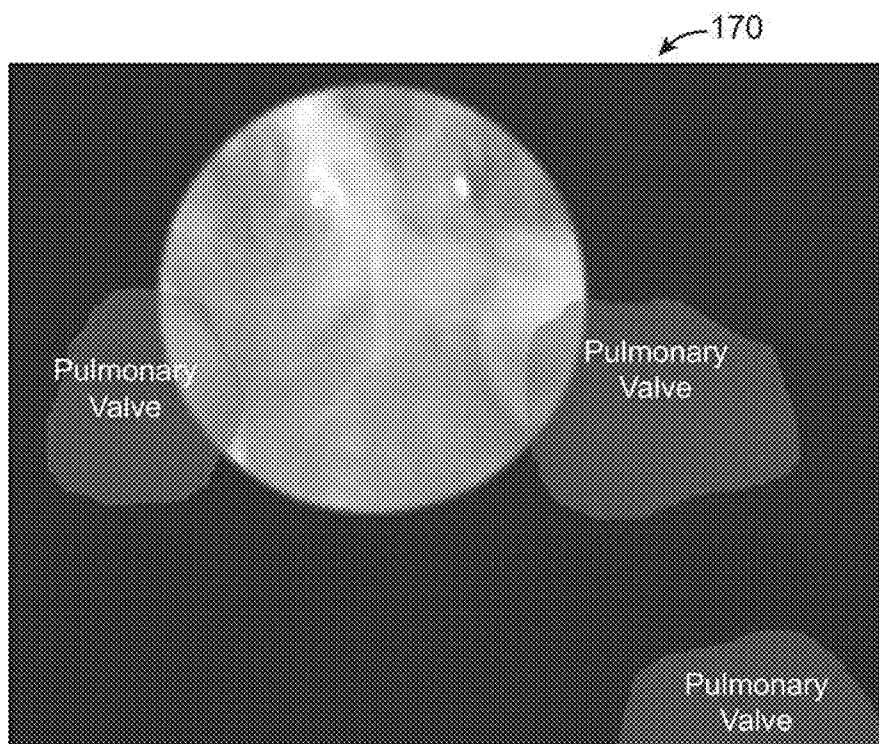

FIG. 16B

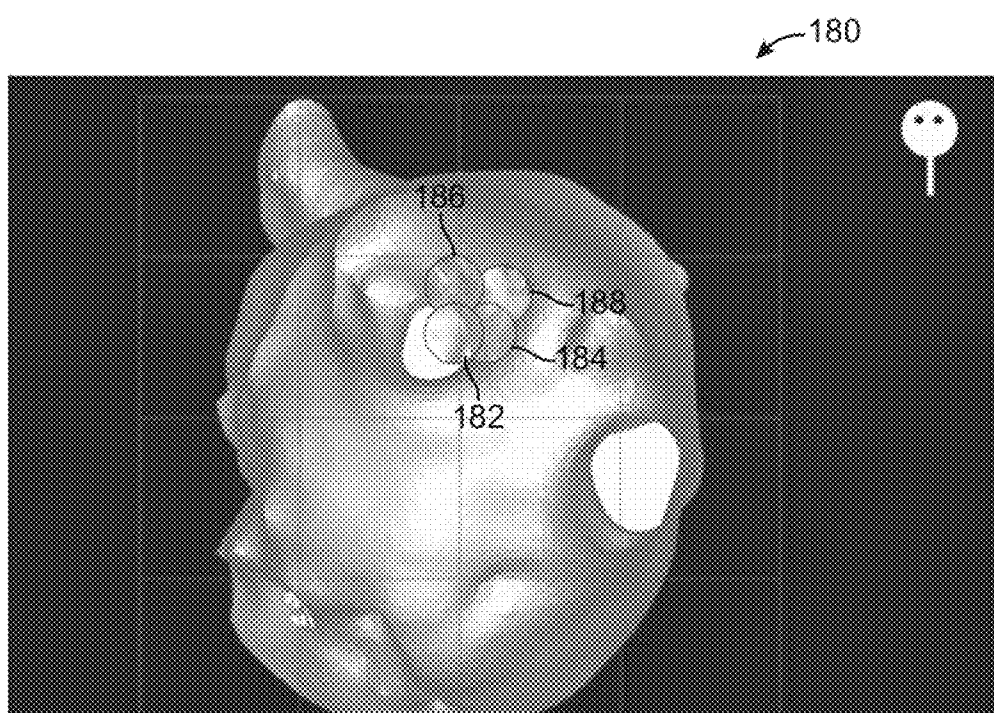

FIG. 17

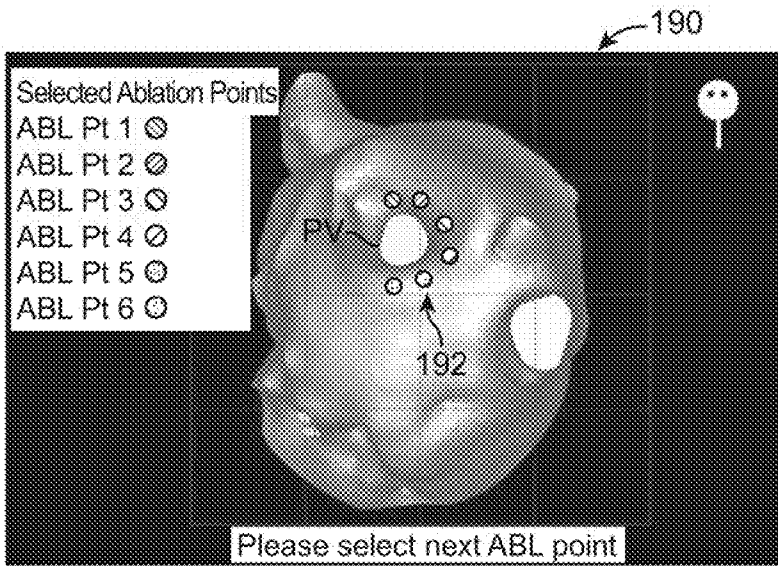

FIG. 18A

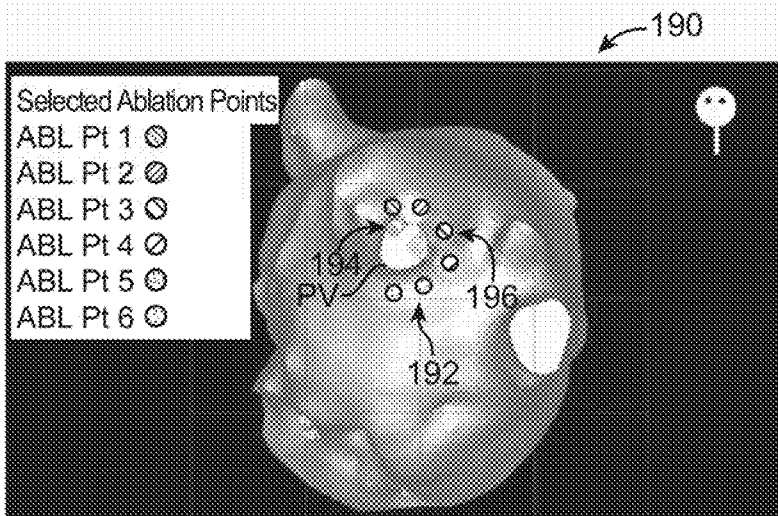

FIG. 18B

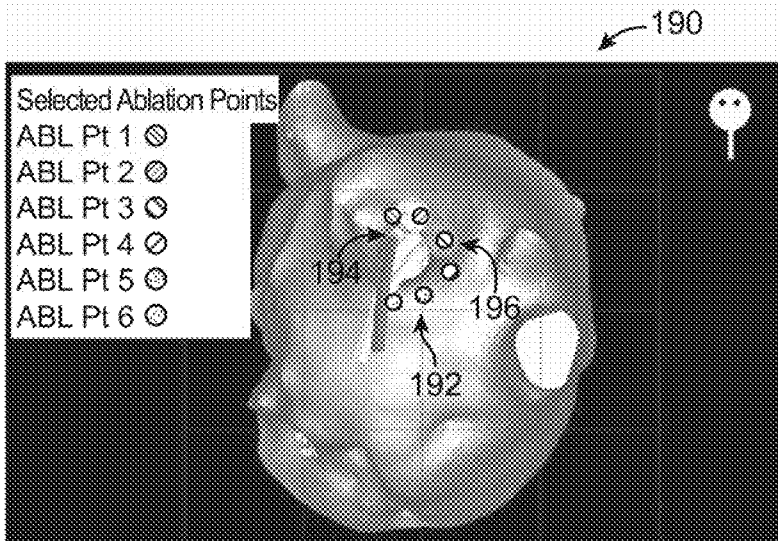

FIG. 18C

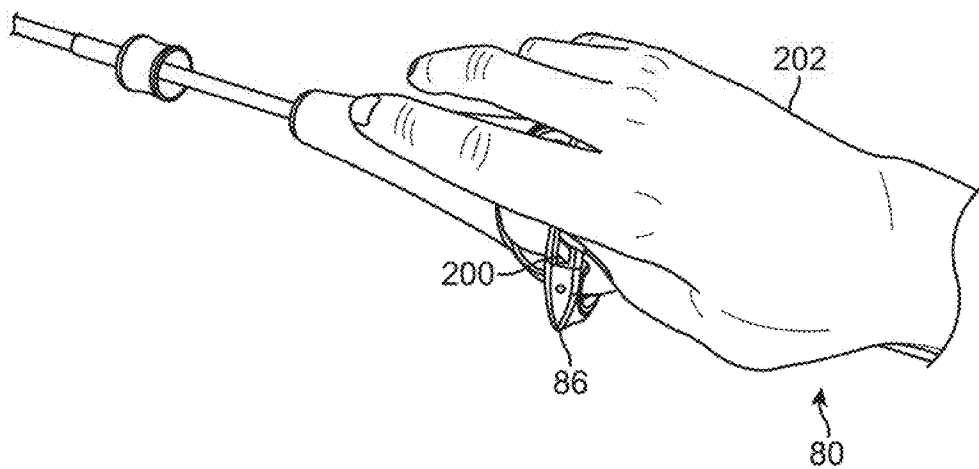

FIG. 19

**IN-VIVO VISUALIZATION SYSTEMS**

**CROSS-REFERENCE TO RELATED APPLICATIONS**

**[0001]** This application claims the benefit of priority to U.S. Prov. Pat. App. 61/177,618 filed May 12, 2009, which is incorporated herein by reference in its entirety.

**FIELD OF THE INVENTION**

**[0002]** The present invention relates generally to medical devices used for visualizing and/or assessing regions of tissue within a body. More particularly, the present invention relates to methods and apparatus for visualizing and/or assessing regions of tissue within a body, such as the chambers of a heart, to facilitate diagnoses and/or treatments for the tissue.

**BACKGROUND OF THE INVENTION**

**[0003]** Conventional devices for visualizing interior regions of a body lumen are known. For example, ultrasound devices have been used to produce images from within a body in vivo. Ultrasound has been used both with and without contrast agents, which typically enhance ultrasound-derived images.

**[0004]** Other conventional methods have utilized catheters or probes having position sensors deployed within the body lumen, such as the interior of a cardiac chamber. These types of positional sensors are typically used to determine the movement of a cardiac tissue surface or the electrical activity within the cardiac tissue. When a sufficient number of points have been sampled by the sensors, a “map” of the cardiac tissue may be generated.

**[0005]** Another conventional device utilizes an inflatable balloon which is typically introduced intravascularly in a deflated state and then inflated against the tissue region to be examined. Imaging is typically accomplished by an optical fiber or other apparatus such as electronic chips for viewing the tissue through the membrane(s) of the inflated balloon. Moreover, the balloon must generally be inflated for imaging. Other conventional balloons utilize a cavity or depression formed at a distal end of the inflated balloon. This cavity or depression is pressed against the tissue to be examined and is flushed with a clear fluid to provide a clear pathway through the blood.

**[0006]** However, such imaging balloons have many inherent disadvantages. For instance, such balloons generally require that the balloon be inflated to a relatively large size which may undesirably displace surrounding tissue and interfere with fine positioning of the imaging system against the tissue. Moreover, the working area created by such inflatable balloons are generally cramped and limited in size. Furthermore, inflated balloons may be susceptible to pressure changes in the surrounding fluid. For example, if the environment surrounding the inflated balloon undergoes pressure changes, e.g., during systolic and diastolic pressure cycles in a beating heart, the constant pressure change may affect the inflated balloon volume and its positioning to produce unsteady or undesirable conditions for optimal tissue imaging. Additionally, imaging balloons are subject to producing poor or blurred tissue images if the balloon is not firmly pressed against the tissue surface because of intervening blood between the balloon and tissue.

**[0007]** Accordingly, these types of imaging modalities are generally unable to provide desirable images useful for suf-

ficient diagnosis and therapy of the endoluminal structure, due in part to factors such as dynamic forces generated by the natural movement of the heart. Moreover, anatomic structures within the body can occlude or obstruct the image acquisition process. Also, the presence and movement of opaque bodily fluids such as blood generally make in vivo imaging of tissue regions within the heart difficult. Moreover, once a visual image of a tissue region is acquired in vivo, there may be additional difficulties in assessing the condition of the underlying tissue for appropriate treatments or treatment parameters.

**[0008]** Thus, a tissue imaging system which is able to provide real-time in vivo images and assessments of tissue regions within body lumens such as the heart through opaque media such as blood and which also provide instruments for therapeutic procedures upon the visualized tissue are desirable.

**SUMMARY OF THE INVENTION**

**[0009]** In describing the tissue imaging and manipulation apparatus that may be utilized for procedures within a body lumen, such as the heart, in which visualization of the surrounding tissue is made difficult, if not impossible, by medium contained within the lumen such as blood, is described below. Generally, such a tissue imaging and manipulation apparatus comprises an optional delivery catheter or sheath through which a deployment catheter and imaging hood may be advanced for placement against or adjacent to the tissue to be imaged.

**[0010]** The deployment catheter may define a fluid delivery lumen therethrough as well as an imaging lumen within which an optical imaging fiber or assembly may be disposed for imaging tissue. When deployed, the imaging hood may be expanded into any number of shapes, e.g., cylindrical, conical as shown, semi-spherical, etc., provided that an open area or field is defined by the imaging hood. The open area is the area through which the tissue region of interest may be imaged. Additionally, the tissue may be viewed not only through the aperture but also through the distal membrane. The imaging hood may also define an atraumatic contact lip or edge for placement or abutment against the tissue region of interest. Moreover, the distal end of the deployment catheter or separate manipulatable catheters may be articulated through various controlling mechanisms such as push-pull wires manually or via computer control

**[0011]** The deployment catheter may also be stabilized relative to the tissue surface through various methods. For instance, inflatable stabilizing balloons positioned along a length of the catheter may be utilized, or tissue engagement anchors may be passed through or along the deployment catheter for temporary engagement of the underlying tissue.

**[0012]** In operation, after the imaging hood has been deployed, fluid may be pumped at a positive pressure through the fluid delivery lumen until the fluid fills the open area completely and displaces any blood from within the open area. The fluid may comprise any biocompatible fluid, e.g., saline, water, plasma, Fluorinert™, etc., which is sufficiently transparent to allow for relatively undistorted visualization through the fluid. The fluid may be pumped continuously or intermittently to allow for image capture by an optional processor which may be in communication with the assembly.

**[0013]** In an exemplary variation for imaging tissue surfaces within a heart chamber containing blood, the tissue imaging and treatment system may generally comprise a

catheter body having a lumen defined therethrough, a visualization element disposed adjacent the catheter body, the visualization element having a field of view, a transparent or translucent fluid source in fluid communication with the lumen, and a barrier or membrane extendable from the catheter body to localize, between the visualization element and the field of view, displacement of blood by transparent fluid that flows from the lumen, and an instrument translatable through the displaced blood for performing any number of treatments upon the tissue surface within the field of view. The imaging hood may be formed into any number of configurations and the imaging assembly may also be utilized with any number of therapeutic tools which may be deployed through the deployment catheter.

**[0014]** More particularly in certain variations, the tissue visualization system may comprise components including the imaging hood, where the hood may further include a membrane having a main aperture and additional optional openings disposed over the distal end of the hood. An introducer sheath or the deployment catheter upon which the imaging hood is disposed may further comprise a steerable segment made of multiple adjacent links which are pivotably connected to one another and which may be articulated within a single plane or multiple planes. The deployment catheter itself may be comprised of a multiple lumen extrusion, such as a four-lumen catheter extrusion, which is reinforced with braided stainless steel fibers to provide structural support. The proximal end of the catheter may be coupled to a handle for manipulation and articulation of the system.

**[0015]** To provide visualization, an imaging element such as a fiberoptic or electronic imager such as a solid state camera, e.g., CCD or CMOS, may be mounted, e.g., on a shape memory wire, and positioned within or along the hood interior. A fluid reservoir and/or pump (e.g., syringe, pressurized intravenous bag, etc.) may be fluidly coupled to the proximal end of the catheter to hold the translucent fluid such as saline or contrast medium as well as for providing the pressure to inject the fluid into the imaging hood.

**[0016]** In clearing the hood of blood and/or other bodily fluids, it is generally desirable to purge the hood in an efficient manner by minimizing the amount of clearing fluid, such as saline, introduced into the hood and thus into the body. As excessive saline delivered into the blood stream of patients with poor ventricular function may increase the risk of heart failure and pulmonary edema, minimizing or controlling the amount of saline discharged during various therapies, such as atrial fibrillation ablation, atrial flutter ablation, transseptal puncture, etc. may be generally desirable.

**[0017]** Steering of the hood assembly via controls on the handle may present some difficulties particularly when the catheter assembly has been contorted into various configurations by patient anatomies. This contortion may result in a mismatch between the steering controls and the corresponding movement on the screen of the in-vivo visualization system potentially leading to the user having to make constant micro movements on the steering controls to mentally re-map the direction of movement on the screen to the steering controls. This constant readjustment increases procedure times and may put undue stress and frustration on the user performing the treatment. This may continue to exist even with the addition of three-dimensional visualization systems as the movement of the catheter hood may not correspond to the real-time images viewed on the screen projecting the tissue images. Directional indicators on the visualization screen,

in-vivo visualization screen, as well as on the steering controls may help to give the user a sense of orientation of the catheter device with respect to the in-vivo image being viewed. With this sense of orientation, users of the catheter device may be intuitively aware of the direction in which they should manipulate the tip of the device in order to access a specific region of anatomy.

**[0018]** In order to help physicians gain a better sense of the catheter hood orientation, color coded directional indicators, e.g., illustrated as dots or other symbols, may be used to represent a specific section of the catheter hood. At least one of these color coded dots or symbols may be placed on a representation of the catheter assembly on the monitor, on the in vivo visualization monitor, and on the steering controls of the catheter handle. For illustrative purposes, the dots or symbols (which may also be optionally color-coded) may represent one of four directional indicators which may be represented on the monitors.

**[0019]** In yet another variation, one or more of the directional indicators located on the handle assembly may be configured as tactile sensors. When a user places their hand or finger upon one of the tactile sensors, the corresponding directional indicator displayed on the positional image may begin to blink, flash, or otherwise provide some indication that the corresponding direction on the control handle has been activated thus giving the user an immediate indication as to which portion of the handle control to manipulate without having to move their eyes from the monitors. The touch-sensitive sensors located on the handle assembly may be configured as touch-sensitive sensors utilizing any number of known mechanisms, such as capacitive sensors or pressure-sensitive sensors, etc.

**[0020]** Aside from the use of directional indicators and generated positional information, other mechanisms may be utilized for making the manipulation and steering of the hood relative to the body more intuitive. One example may utilize rotation of the image on the monitor showing the visualized tissue to affix a direction on the monitor to a direction of mechanical actuation on the control handle depending upon how the handle is re-orientated. In another variation, rather than rotating the images of the tissue based on the movement and rotation of the catheter handle, the images of the tissue may be fixed and the steering controls instead may be remapped.

**[0021]** In yet another variation for facilitating tissue treatment, the captured visual image of the tissue as imaged through the hood may be projected and mapped to the representative map of the tissue anatomy. Being able to visualize the "active spot" that is being visualized through the hood by mapping it onto the surface of the representative three-dimensional model may allow the physician to more accurately navigate the anatomy. When visualizing and treating tissue using the visualization system, the catheter hood may not necessarily be visualizing the tissue that is seen on the in vivo visualization system. This may occur due to a variety of reasons such as non-perpendicularity of the hood to the tissue surface or contortion of the hood. Because the active spot moves as the catheter hood is being moved, this may give the physician a greater awareness and confidence on both the visualization systems.

**[0022]** In yet another example, way-pointing methods may also be utilized to facilitate tissue treatment by the physician. Way-pointing is a pre-operative method that allows the physician to map out the ablation procedure by selecting lesion

sites on the three-dimensional model of the anatomy. This data may be then transmitted to the catheter system which may generate and project approximated lesion boundaries to be formed as well as the navigational information to guide the hood from one lesion to another as the procedure progresses. Such a way-pointing system may prevent the user from becoming disoriented in the anatomy of the heart and may effectively speed procedure times while ensuring that lesions are contiguously formed, if necessary or desired, by showing lesion boundaries.

**[0023]** Additionally and/or alternatively, other methods for helping the user to maintain spatial awareness of the surrounding tissue and anatomical features may also be utilized for facilitating navigation, safety, procedure efficacy, etc. The features to be displayed may be pre-selected on the three-dimensional visualization model prior to treatment. These points of interest may allow the user to establish a base of reference when they are viewing the images of tissue on the monitor. Additionally, the indication of surrounding tissue regions may help to ensure the avoidance of inadvertently treating tissue surrounding the tissue region of interest.

**[0024]** Yet another example for facilitating tissue treatment procedures may utilize the augmentation of images utilizing previously captured images. For instance, captured images previously visualized through the hood and recorded may be compiled and stitched relative to one another to provide a seamless interior map of the anatomy. This image stitching may present an actual map of the interior of the heart instead of an approximate three-dimensional model. Moreover, the images can also be mapped such that they take on the contours of the model. Being able to see the actual visual inside the heart may increase physician confidence and also the speed of the procedure.

**[0025]** Procedure guidance systems are particularly useful when the user may be unfamiliar with the device and its capabilities or wish to facilitate the procedure by minimizing steering decisions from one ablation point to another. Such a system may function by first allowing the user to select potential ablation sites, e.g., in proximity to a pulmonary vein ostium, on either a pre-operative three-dimensional model or on a uniquely generated three-dimensional model. Physicians can then navigate the catheter hood into the particular orientation before performing ablation. Additionally, for steerable sections with a plurality of sensors, the steerable section can be graphically represented as well.

#### BRIEF DESCRIPTION OF THE DRAWINGS

**[0026]** FIG. 1A shows a side view of one variation of a tissue imaging apparatus during deployment from a sheath or delivery catheter.

**[0027]** FIG. 1B shows the deployed tissue imaging apparatus of FIG. 1A having an optionally expandable hood or sheath attached to an imaging and/or diagnostic catheter.

**[0028]** FIG. 1C shows an end view of a deployed imaging apparatus.

**[0029]** FIGS. 2A and 2B show one example of a deployed tissue imager positioned against or adjacent to the tissue to be imaged and a flow of fluid, such as saline, displacing blood from within the expandable hood.

**[0030]** FIGS. 3A and 3B show examples of various visualization imagers which may be utilized within or along the imaging hood.

**[0031]** FIGS. 4A and 4B show perspective and end views, respectively, of an imaging hood having at least one layer of a transparent elastomeric membrane over the distal opening of the hood.

**[0032]** FIGS. 5A and 5B show perspective and end views, respectively, of an imaging hood which includes a membrane with an aperture defined therethrough and a plurality of additional openings defined over the membrane surrounding the aperture.

**[0033]** FIG. 6 shows one variation of an articulatable deployment catheter having a distal steerable section and a proximal steerable section with a three-dimensional model illustrating a representation of the hood assembly within the body and the visual image of the tissue region captured through the hood.

**[0034]** FIG. 7A shows a representative image of a hood assembly positioned within a generated three-dimensional model of the left atrial chamber of a heart in proximity to the pulmonary veins.

**[0035]** FIGS. 7B and 7C show captured tissue images visualized through the hood with directional indicators superimposed upon the images.

**[0036]** FIGS. 8A and 8B show perspective views of directional indicators positioned upon the hood as well as on the handle assembly which correspond with one another.

**[0037]** FIG. 9A shows a representative image of the hood assembly within a three-dimensional model of the left atrial chamber with the directional indicators imaged thereon.

**[0038]** FIGS. 9B and 9C show perspective views of a handle assembly having touch-sensitive sensors on the manipulation control.

**[0039]** FIGS. 10A to 10C show an example of a perspective view of a handle assembly manipulated in a first direction to move an imaged region, respectively.

**[0040]** FIGS. 11A to 11C show the handle assembly of FIG. 10A rotated about its longitudinal axis and manipulated again in the first direction to move an imaged region in a consistent manner, respectively.

**[0041]** FIGS. 12A to 12C show another example of a perspective view of a handle assembly manipulated in a first direction to move an imaged region, respectively.

**[0042]** FIGS. 13A to 13C show the handle assembly of FIG. 12A rotated about its longitudinal axis and manipulated again in the first direction to move an imaged region in a consistent manner, respectively.

**[0043]** FIG. 14A shows a perspective view of a hood assembly having one or more sensors positioned along at least one of the steerable sections.

**[0044]** FIGS. 14B and 14C show three-dimensional generated models illustrating representative images of the hood assembly and its curved steerable segment relative to the tissue.

**[0045]** FIG. 15A shows an example of a three-dimensional generated model illustrating a representative image of the hood assembly and an image of tissue captured from the hood and superimposed upon the model.

**[0046]** FIG. 15B shows another example of a three-dimensional generated model illustrating pre-selected way points for ablation treatment imaged upon the model.

**[0047]** FIG. 16A shows an imaged region of tissue visualized through the hood with navigational information superimposed upon the image.

**[0048]** FIG. 16B shows another example of an imaged region of tissue visualized through the hood with anatomical in proximity to the imaged region superimposed upon the tissue image.

**[0049]** FIG. 17 shows another example of a three-dimensional generated model having multiple tissue images stitched together and superimposed upon the model.

**[0050]** FIGS. 18A to 18C show another example of a three-dimensional generated model having pre-selected ablation points and representative images of the hood assembly idealized for treatment along these ablation points.

**[0051]** FIG. 19 shows a perspective view of a handle assembly variation configured to generate tactile sensations such as force feedback on the steering control for providing force feedback to the user's hand.

#### DETAILED DESCRIPTION OF THE INVENTION

**[0052]** Reconfiguring a tissue visualization and treatment device from a low profile delivery configuration for intravascular delivery through the vessels of a patient to a deployed and expanded configuration may subject the distal end effector used for visualization and/or treatment, such as energy delivery, to potentially severe mechanical stresses (e.g., torsion, compression, tension, shearing, etc.). For example, a reconfigurable hood which undergoes a shape change from its collapsed configuration to an expanded conical shape may utilize a distensible, collapsible, and/or reconfigurable substrate which may utilize electrode placement and electrical connection assemblies which are robust and able to withstand such stresses. Such electrical connection assemblies may be shielded or insulated from contacting other structures so as to present a smooth or unobstructive profile for reconfiguring with the hood.

**[0053]** Turning now to the tissue-imaging and manipulation apparatus, such an apparatus may have one or more electrodes positioned thereon and also provide real-time images in vivo of tissue regions within a body lumen such as a heart, which is filled with blood flowing dynamically there-through. The apparatus is also able to provide intravascular tools and instruments for performing various procedures upon the imaged tissue regions. Such an apparatus may be utilized for many procedures, e.g., facilitating transseptal access to the left atrium, cannulating the coronary sinus, diagnosis of valve regurgitation/stenosis, valvuloplasty, atrial appendage closure, arrhythmogenic focus ablation, among other procedures.

**[0054]** One variation of a tissue access and imaging apparatus is shown in the detail perspective views of FIGS. 1A to 1C. As shown in FIG. 1A, tissue imaging and manipulation assembly 10 may be delivered intravascularly through the patient's body in a low-profile configuration via a delivery catheter or sheath 14. In the case of treating tissue, it is generally desirable to enter or access the left atrium while minimizing trauma to the patient. To non-operatively effect such access, one conventional approach involves puncturing the intra-atrial septum from the right atrial chamber to the left atrial chamber in a procedure commonly called a transseptal procedure or septostomy. For procedures such as percutaneous valve repair and replacement, transseptal access to the left atrial chamber of the heart may allow for larger devices to be introduced into the venous system than can generally be introduced percutaneously into the arterial system.

**[0055]** When the imaging and manipulation assembly 10 is ready to be utilized for imaging tissue, imaging hood 12 may

be advanced relative to catheter 14 and deployed from a distal opening of catheter 14, as shown by the arrow. Upon deployment, imaging hood 12 may be unconstrained to expand or open into a deployed imaging configuration, as shown in FIG. 18. Imaging hood 12 may be fabricated from a variety of pliable or conformable biocompatible material including but not limited to, e.g., polymeric, plastic, or woven materials. One example of a woven material is Kevlar® (E. I. du Pont de Nemours, Wilmington, Del.), which is an aramid and which can be made into thin, e.g., less than 0.001 in., materials which maintain enough integrity for such applications described herein. Moreover, the imaging hood 12 may be fabricated from a translucent or opaque material and in a variety of different colors to optimize or attenuate any reflected lighting from surrounding fluids or structures, i.e., anatomical or mechanical structures or instruments. In either case, imaging hood 12 may be fabricated into a uniform structure or a scaffold-supported structure, in which case a scaffold made of a shape memory alloy, such as Nitinol, or a spring steel, or plastic, etc., may be fabricated and covered with the polymeric, plastic, or woven material. Hence, imaging hood 12 may comprise any of a wide variety of barriers or membrane structures, as may generally be used to localize displacement of blood or the like from a selected volume of a body lumen or heart chamber. In exemplary embodiments, a volume within an inner surface 13 of imaging hood 12 will be significantly less than a volume of the hood 12 between inner surface 13 and outer surface 11.

**[0056]** Imaging hood 12 may be attached at interface 24 to a deployment catheter 16 which may be translated independently of deployment catheter or sheath 14.

**[0057]** Attachment of interface 24 may be accomplished through any number of conventional methods. Deployment catheter 16 may define a fluid delivery lumen 18 as well as an imaging lumen 20 within which an optical imaging fiber or assembly may be disposed for imaging tissue. When deployed, imaging hood 12 may expand into any number of shapes, e.g., cylindrical, conical as shown, semi-spherical, etc., provided that an open area or field 26 is defined by imaging hood 12. The open area 26 is the area within which the tissue region of interest may be imaged. Imaging hood 12 may also define an atraumatic contact lip or edge 22 for placement or abutment against the tissue region of interest. Moreover, the diameter of imaging hood 12 at its maximum fully deployed diameter, e.g., at contact lip or edge 22, is typically greater relative to a diameter of the deployment catheter 16 (although a diameter of contact lip or edge 22 may be made to have a smaller or equal diameter of deployment catheter 16). For instance, the contact edge diameter may range anywhere from 1 to 5 times (or even greater, as practicable) a diameter of deployment catheter 16. FIG. 1C shows an end view of the imaging hood 12 in its deployed configuration. Also shown are the contact lip or edge 22 and fluid delivery lumen 18 and imaging lumen 20.

**[0058]** As seen in the example of FIGS. 2A and 2B, deployment catheter 16 may be manipulated to position deployed imaging hood 12 against or near the underlying tissue region of interest to be imaged, in this example a portion of annulus A of mitral valve MV within the left atrial chamber. As the surrounding blood 30 flows around imaging hood 12 and within open area 26 defined within imaging hood 12, as seen in FIG. 2A, the underlying annulus A is obstructed by the opaque blood 30 and is difficult to view through the imaging lumen 20. The translucent fluid 28, such as saline, may then



be pumped through fluid delivery lumen 18, intermittently or continuously, until the blood 30 is at least partially, and preferably completely, displaced from within open area 26 by fluid 28, as shown in FIG. 2B.

[0059] Although contact edge 22 need not directly contact the underlying tissue, it is at least preferably brought into close proximity to the tissue such that the flow of clear fluid 28 from open area 26 may be maintained to inhibit significant backflow of blood 30 back into open area 26. Contact edge 22 may also be made of a soft elastomeric material such as certain soft grades of silicone or polyurethane, as typically known, to help contact edge 22 conform to an uneven or rough underlying anatomical tissue surface. Once the blood 30 has been displaced from imaging hood 12, an image may then be viewed of the underlying tissue through the clear fluid 30. This image may then be recorded or available for real-time viewing for performing a therapeutic procedure. The positive flow of fluid 28 may be maintained continuously to provide for clear viewing of the underlying tissue. Alternatively, the fluid 28 may be pumped temporarily or sporadically only until a clear view of the tissue is available to be imaged and recorded, at which point the fluid flow 28 may cease and blood 30 may be allowed to seep or flow back into imaging hood 12. This process may be repeated a number of times at the same tissue region or at multiple tissue regions.

[0060] FIG. 3A shows a partial cross-sectional view of an example where one or more optical fiber bundles 32 may be positioned within the catheter and within imaging hood 12 to provide direct in-line imaging of the open area within hood 12. FIG. 3B shows another example where an imaging element 34 (e.g., CCD or CMOS electronic imager) may be placed along an interior surface of imaging hood 12 to provide imaging of the open area such that the imaging element 34 is off-axis relative to a longitudinal axis of the hood 12, as described in further detail below. The off-axis position of element 34 may provide for direct visualization and uninhibited access by instruments from the catheter to the underlying tissue during treatment. Additionally and/or alternatively, the electronic imaging element 34 (e.g., CCD or CMOS) may also be positioned along or in proximity to the longitudinal axis of the catheter to provide in-line imaging of the open area.

[0061] In utilizing the imaging hood 12 in any one of the procedures described herein, the hood 12 may have an open field which is uncovered and clear to provide direct tissue contact between the hood interior and the underlying tissue to effect any number of treatments upon the tissue, as described above. Yet in additional variations, imaging hood 12 may utilize other configurations. An additional variation of the imaging hood 12 is shown in the perspective and end views, respectively, of FIGS. 4A and 4B, where imaging hood 12 includes at least one layer of a transparent elastomeric membrane 40 over the distal opening of hood 12. An aperture 42 having a diameter which is less than a diameter of the outer lip of imaging hood 12 may be defined over the center of membrane 40 where a longitudinal axis of the hood intersects the membrane such that the interior of hood 12 remains open and in fluid communication with the environment external to hood 12. Furthermore, aperture 42 may be sized, e.g., between 1 to 2 mm or more in diameter and membrane 40 can be made from any number of transparent elastomers such as silicone, polyurethane, latex, etc. such that contacted tissue may also be visualized through membrane 40 as well as through aperture 42.

[0062] Aperture 42 may function generally as a restricting passageway to reduce the rate of fluid out-flow from the hood 12 when the interior of the hood 12 is infused with the clear fluid through which underlying tissue regions may be visualized. Aside from restricting out-flow of clear fluid from within hood 12, aperture 42 may also restrict external surrounding fluids from entering hood 12 too rapidly. The reduction in the rate of fluid out-flow from the hood and blood in-flow into the hood may improve visualization conditions as hood 12 may be more readily filled with transparent fluid rather than being filled by opaque blood which may obstruct direct visualization by the visualization instruments.

[0063] Moreover, aperture 42 may be aligned with catheter 16 such that any instruments (e.g., piercing instruments, guidewires, tissue engagers, etc.) that are advanced into the hood interior may directly access the underlying tissue uninhibited or unrestricted for treatment through aperture 42. In other variations wherein aperture 42 may not be aligned with catheter 16, instruments passed through catheter 16 may still access the underlying tissue by simply piercing through membrane 40.

[0064] In an additional variation, FIGS. 5A and 5B show perspective and end views, respectively, of imaging hood 12 which includes membrane 40 with aperture 42 defined there-through, as described above. This variation includes a plurality of additional openings 44 defined over membrane 40 surrounding aperture 42. Additional openings 44 may be uniformly sized, e.g., each less than 1 mm in diameter, to allow for the out-flow of the translucent fluid therethrough when in contact against the tissue surface. Moreover, although openings 44 are illustrated as uniform in size, the openings may be varied in size and their placement may also be non-uniform or random over membrane 40 rather than uniformly positioned about aperture 42 in FIG. 5B. Furthermore, there are eight openings 44 shown in the figures although fewer than eight or more than eight openings 44 may also be utilized over membrane 40.

[0065] Additional details of tissue imaging and manipulation systems and methods which may be utilized with apparatus and methods described herein are further described, for example, in U.S. patent application Ser. No. 11/259,498 filed Oct. 25, 2005 (U.S. Pat. Pub. 2006/0184048 A1), which is incorporated herein by reference in its entirety.

[0066] In utilizing the devices and methods above, various procedures may be accomplished. One example of such a procedure is crossing a tissue region such as in a transseptal procedure where a septal wall is pierced and traversed, e.g., crossing from a right atrial chamber to a left atrial chamber in a heart of a subject. Generally, in piercing and traversing a septal wall, the visualization and treatment devices described herein may be utilized for visualizing the tissue region to be pierced as well as monitoring the piercing and access through the tissue. Details of transseptal visualization catheters and methods for transseptal access which may be utilized with the apparatus and methods described herein are described in U.S. patent application Ser. No. 11/763,399 filed Jun. 14, 2007 (U.S. Pat. Pub. 2007/0293724 A1), which is incorporated herein by reference in its entirety. Additionally, details of tissue visualization and manipulation catheter which may be utilized with apparatus and methods described herein are described in U.S. patent application Ser. No. 11/259,498 filed Oct. 25, 2005 (U.S. Pat. Pub. 2006/0184048 A1), which is incorporated herein by reference in its entirety.

[0067] In clearing the hood of blood and/or other bodily fluids, it is generally desirable to purge the hood in an efficient manner by minimizing the amount of clearing fluid, such as saline, introduced into the hood and thus into the body. As excessive saline delivered into the blood stream of patients with poor ventricular function may increase the risk of heart failure and pulmonary edema, minimizing or controlling the amount of saline discharged during various therapies, such as atrial fibrillation ablation, atrial flutter ablation, transseptal puncture, etc. may be generally desirable.

[0068] Turning now to the electrode assemblies and connection systems utilized with the collapsible hood, various examples are described herein which illustrate variations for electrode positioning along the hood which may minimize or reduce the degree of stress imparted to the electrode assemblies. These electrodes (e.g., electrode pairs) may be used to deliver electrical energy such as radio-frequency energy to tissue in direct contact with or in proximity to the electrodes to form lesions upon the tissue surface as well as underlying tissue regions. Additionally, the electrodes or electrode pairs may be positioned about the hood in a uniform or non-uniform manner depending upon the desired configuration. Moreover, these electrodes may also be used to deliver energy into and/or through the purging fluid which may contact the electrodes for conducting the energy through the fluid and into the underlying tissue region being treated. Alternatively, one or more of these electrodes may also be used to detect and/or measure any electrophysiological activity of the contacted tissue prior to, during, or after tissue treatment.

[0069] While specific examples of the visualization and treatment hood are shown herein, other variations and examples of hoods and tissue treatment systems may be utilized with the devices and methods described herein. For example, the hoods, systems, and other features as described in Ser. Nos. 11/259,498 filed Oct. 25, 2005 (U.S. Pat. Pub. 2006/0184048 A1); 11/775,837 filed Jul. 10, 2007 (U.S. Pat. Pub. 2008/0009747 A1); 11/828,267 filed Jul. 25, 2007 (U.S. Pat. Pub. No. 2008/0033290 A1); 12/118,439 filed May 9, 2008 (U.S. Pat. Pub. 2009/0030412 A1); 12/201,811 filed Aug. 29, 2008 (U.S. Pat. Pub. 2009/0062790 A1); and 12/209,057 filed Sep. 11, 2008 (U.S. Pat. Pub. 20090076498 A1), may be utilized herewith. Each of these applications is incorporated herein by reference in its entirety.

[0070] In particular, such assemblies, apparatus, and methods may be utilized for treatment of various conditions, e.g., arrhythmias, through ablation under direct visualization. Details of examples for the treatment of arrhythmias under direct visualization which may be utilized with apparatus and methods described herein are described, for example, in U.S. patent application Ser. No. 11/775,819 filed Jul. 10, 2007 (U.S. Pat. Pub. No. 2008/0015569 A1), which is incorporated herein by reference in its entirety. Variations of the tissue imaging and manipulation apparatus may be configured to facilitate the application of bipolar energy delivery, such as radio-frequency (RF) ablation, to an underlying target tissue for treatment in a controlled manner while directly visualizing the tissue during the bipolar ablation process as well as confirming (visually and otherwise) appropriate treatment thereafter.

[0071] Steering of the hood assembly via controls on the handle may present some difficulties particularly when the catheter assembly has been contorted into various configurations by patient anatomies. This contortion may result in a mismatch between the steering controls and the correspond-

ing movement on the screen of the in-vivo visualization system potentially leading to the user having to make constant micro movements on the steering controls to mentally re-map the direction of movement on the screen to the steering controls. This constant readjustment increases procedure times and may put undue stress and frustration on the user performing the treatment. This may continue to exist even with the addition of three-dimensional visualization systems as the movement of the catheter hood 12 may not correspond to the real-time images viewed on the screen projecting the tissue images. Directional indicators on the visualization screen, in-vivo visualization screen, as well as on the steering controls may help to give the user a sense of orientation of the catheter device with respect to the in-vivo image being viewed. With this sense of orientation, users of the catheter device may be intuitively aware of the direction in which they should manipulate the tip of the device in order to access a specific region of anatomy. Further details for use of directional indicators which may be utilized herein are shown and described in U.S. patent application Ser. No. 12/118,439 filed May 9, 2008 (U.S. Pat. Pub. No. 2009/0030412 A1), which is incorporated herein by reference in its entirety.

[0072] Turning now to the assembly view of FIG. 6, one variation of an articulatable deployment catheter 50 is shown which comprises a distal steerable section 52 and a proximal steerable section 54 located proximally of the distal steerable section 52. Further details of the deployment catheter 50 which may be used herein may be seen in further detail in U.S. patent application Ser. No. 12/108,812 filed Apr. 24, 2008 (U.S. Pat. Pub. No. 2008/0275300 A1) and U.S. patent application Ser. No. 12/618,306 filed Nov. 13, 2009, each of which is incorporated herein by reference in its entirety. As shown, the articulatable deployment catheter 50 may extend from the catheter 16 attached to handle assembly 80. In this variation, the handle assembly 80 may have a handle body 82 and an articulatable proximal steering control 84 which may be manipulated to steer a proximal steerable section 54 within a single plane of articulation. A separate distal steering control 86 which may be manipulated to steer a distal steerable section 52 in any of four planes or more independently of the proximal steerable section 54. A first monitor 88 may be in communication with the catheter assembly 50 to record and display a representative image of the hood 12 orientation of the device relative to the anatomy to show the positional information 90. A second monitor 92 may also be in communication with the catheter assembly 50 to display the visual images of the underlying tissue captured through the hood 12 to show the real-time visual images of tissue 94.

[0073] Additional control and navigation systems which may be utilized herein are shown and described in further detail in U.S. patent application Ser. No. 11/848,429 filed Aug. 31, 2007 (U.S. Pat. Pub. 2008/0097476 A1) and in Ser. No. 11/848,532 also filed Aug. 31, 2007 (U.S. Pat. Pub. 2009/0054803 A1), each of which is incorporated herein by reference in its entirety.

[0074] An intervening link 56 may couple the sections 52, 54 to one another and provide a terminal link to which one or more pull wires may be attached in controlling one or both sections. The distal steerable section 52 may utilize individual links 66 which allow for the section 52 to be articulated in a variety of different directions and angles, e.g., four-way steering, to enable omni-direction articulation. The individual links 66 may accordingly utilize a body member 68 having a pair of yoke members 70 positioned opposite to one

another and extending distally from the body member 68 and each defining an opening. A pair of pins 72 may each extend radially in opposing directions from body member 68 and in a perpendicular plane relative to a plane defined by the yoke members 70. The pins 72 of each link 66 may be pivotably received by the yoke members 70 of an adjacent link 66 such that the pins 72 and yoke members 70 are joined in an alternating manner. This alternating connection allows for the serially aligned links 66 to be articulated omni-directionally.

[0075] The links 58 of the proximal steering section 54 may also comprise a pair of yoke members 62 positioned opposite to one another and extending distally from body member 60. However, the pins 64 may extend radially in opposing directions while remaining in the same plane as that defined by yoke members 62. When joined together in series, each pin 64 of each link 58 may be pivotably received by the yoke members 62 of an adjacent link 58. Yet when joined, the composite proximal steering section 54 may be constrained to bend planarly within a single plane relative to the rest of the deployment catheter.

[0076] The combined distal steerable section 52 and a proximal steerable section 54 results in a proximal steering section which can be articulated in a single plane to retroflex the entire distal assembly and a distal steering section which can then be articulated any number of directions, e.g., four-way steering, to access anatomical structures within the heart or any other lumen. The assembly may thus be used, e.g., to create circumferential lesions around the ostia of the pulmonary veins in the left atrium while the underlying tissue remains under direct visualization through the hood.

[0077] In order to help physicians gain a better sense of the catheter hood orientation, color coded directional indicators, e.g., illustrated as dots or other symbols, may be used to represent a specific section of the catheter hood 12. At least one of these color coded dots or symbols may be placed on a representation of the catheter assembly on the monitor, on the in vivo visualization monitor, and on the steering controls of the catheter handle. For illustrative purposes, the dots or symbols (which may also be optionally color-coded) may represent one of four directional indicators which may be represented on the monitors, as shown in FIG. 7A the representative image of a hood assembly is positioned within a generated three-dimensional model of the left atrial chamber LA of a heart in proximity to the pulmonary veins PV. The representative image of the hood assembly may be generated, as described previously, and imaged to show a real time representation of the hood orientation relative to the tissue.

[0078] The image of the positional information 100 may be seen where, e.g., a first directional indicator 102 shown as a blue dot, may be assigned a first position along the hood 12, a second directional indicator 104 shown as a red triangle, may be assigned a second position along the hood 12, a third directional indicator 106 shown as a yellow star may be assigned a third position along the hood 12, and a fourth directional indicator 108 shown as a green dot may be positioned along a fourth position along the hood 12. The dots or symbols are shown for illustrative purposes and they may be represented by any number of symbols, letters, numbers, etc. so long as they represent indicators which are distinct from one another. Moreover, color-coding may be optionally incorporated and the number and positioning of the indicators may be varied so long as different directions may be discerned by the placement and number of indicators.

[0079] In addition to the generated representative orientation information shown in the displayed image 100, the captured images of the tissue which are visualized through the hood 12 and displayed, e.g., on a second monitor, may be seen in the visualized tissue image 94 of FIG. 7B. Each of the directional indicators 102, 104, 106, 108 may be seen along respective quadrants of the imaged tissue region. These directional indicators may be either imprinted on the distal membrane of the hood 12 such that they correspond with the directional indicators generated and displayed in image 100. Additionally or alternatively, these directional indicators may be generated by a processor and superimposed upon the images of the visualized tissue. Alternately, directional indicators may be placed on the surface of the second monitor 92 using colored stickers, translucent overlays or by marking with a pen on the surface of the monitor. Other variations may utilize directional indicators which may be shown as colored regions or bands 102', 104', 106', 108' which may be displayed and/or superimposed upon the imaged tissue, as shown in FIG. 7C. Further details are also shown and described in U.S. patent application Ser. No. 12/118,439 filed May 9, 2008, which is incorporated herein by reference in its entirety.

[0080] As previously mentioned and as seen in the perspective view of FIG. 8A, directional indicators 102, 104, 106, 108 may be imprinted directly upon the distal membrane 40 of the hood 12 in proximity to the aperture 42. Moreover, the handle assembly 80 may also define, e.g., the one or more markings 104", 106", etc., over the steering controls, as shown in the perspective view of FIG. 8B, which correspond with the identical or similar markings defined along the distal membrane 40 of hood 12. For example, the first directional indicator 102 at the first location along hood 12; the second directional indicator 104 at the second location along hood 12, the third directional indicator 106 at the third location along hood 12, and the fourth directional indicator 108 along the fourth location along hood 12 may be distinct from one another and may correspond to the indicators located on the control 86. Further details of catheter control handles which may be utilized herein are described in further detail in U.S. patent application Ser. No. 12/499,011 filed Jul. 7, 2009, which is incorporated herein by reference in its entirety.

[0081] As the user visualizes the tissue through hood 12, if the hood 12 needed to be repositioned in any particular direction along the tissue, the user may note the direction to be moved relative to the indicators marked on hood 12 and may thus manipulate the controls on control 86 accordingly such that movement of the controls in the chosen direction may articulate the hood 12 in the same direction. Additionally, the generated image of the hood orientation may also display the directional indicators corresponding to the indicators on the hood 12 and the handle 80. Such a feature may be highly advantageous relative to the absence of visual markings as it may be difficult for the user to steer the hood 12 in a desired direction after it is inserted into the patient's body due to the changes in hood orientation relative to the handle 80 orientation.

[0082] In yet another variation, one or more of the directional indicators located on the handle assembly 80 may be configured as tactile sensors. An example is shown in the perspective view of FIG. 9B which shows the directional indicators, which may be color-coded, configured as touch-sensitive sensors 104s, 106s, etc. When a user places their hand or finger upon one of the tactile sensors, such as sensor

**106s** as shown in FIG. 9C, the corresponding directional indicator **106** displayed on positional image **100** in FIG. 9A may begin to blink, flash, or otherwise provide some indication that the corresponding direction on the control handle **80** has been activated thus giving the user an immediate indication as to which portion of the handle control to manipulate without having to move their eyes from the monitors. In addition, when a user places their hand or finger upon one of the tactile sensors, such as sensor **106s** as shown in FIG. 9C, the corresponding directional indicator **106'** displayed on the tissue image **94** in FIG. 7B may begin to blink, flash, or otherwise provide some indication that the corresponding direction on the control handle **80** has been activated thus giving the user an immediate indication as to which portion of the handle control to manipulate without having to move their eyes from the monitors. The touch-sensitive sensors located on the handle assembly **80** may be configured as touch-sensitive sensors utilizing any number of known mechanisms, such as capacitive sensors or pressure-sensitive sensors, etc.

**[0083]** Aside from the use of directional indicators and generated positional information, other mechanisms may be utilized for making the manipulation and steering of the hood relative to the body more intuitive. One example may utilize rotation of the image on the monitor showing the visualized tissue to affix a direction on the monitor to a direction of mechanical actuation on the control handle depending upon how the handle is re-orientated. For example, as shown in the perspective view of FIG. 10A, the control **86** on handle assembly **80** may be articulated in a first direction **114** by manipulating the control **86** along the directional indicator **106s**. This may result in the hood **12** moving in a first direction such that the imaged tissue **110** through the hood **12**, as shown in FIG. 10B, accordingly moves to the left relative to the tissue, as shown in the imaged tissue **112**, as shown in FIG. 10C.

**[0084]** Because of the tortuous nature of patient anatomies, the handle assembly **80** may be rotated about its longitudinal axis relative to the user to position the hood at the distal end of the catheter assembly within the body. As shown in the perspective view of FIG. 11A, handle assembly **80** is shown rotated about its longitudinal axis in a direction or rotation **116**. The directional indicator **106s** may be seen as rotated, e.g., 90 degrees away, into a different position relative to the user such that the directional indicator **108s** now is proximate to the user. Actuation of the control **86** along the directional indicator **108s** may again result in a movement of the hood **12** to the left, as shown by the imaged tissue **110** being moved to the left as shown by the imaged tissue **112**. In this manner, regardless of the rotation of the catheter handle **80** actuation of the control **86** may result in consistent movement of the hood, i.e., actuation to the left results in movement of the hood **12** to the left, actuation to the right results in movement of the hood **12** to the right, etc.

**[0085]** Such movement may be achieved by mechanical mechanisms, such as having a portion of the catheter handle **80** being rotatable about its longitudinal axis to maintain a consistent position of the handle relative to the user. Examples of such a catheter handle assembly as shown and described in further detail in U.S. Prov. App. 61/286,283 filed Dec. 14, 2009 and 61/297,462 filed Jan. 22, 2010, each of which is incorporated herein by reference in its entirety. Alternatively, one or more accelerometers or positional sensors may be incorporated into the handle assembly **80** which communicate with a processor such that movement of the

handle assembly **80** from an initial calibrated position may automatically rotate the images on the monitor to align in a corresponding manner with the rotation of the handle assembly **80**.

**[0086]** In another variation, rather than rotating the images of the tissue based on the movement and rotation of the catheter handle, the images of the tissue may be fixed and the steering controls instead may be remapped. An example is shown in the perspective view of FIG. 12A which shows catheter handle **80** manipulated along a first direction **120** by manipulating control **86** along directional indicator **106s**. The resulting imaged tissue **110**, shown in FIG. 12B, may be accordingly moved in a first corresponding direction, e.g., to the left as shown in the moved tissue image of FIG. 12C. As the handle assembly **80** is rotated to accommodate positioning of the hood within the body, as shown in FIG. 13A, the previously-articulated directional indicator **106s** may be seen rotated into a new position relative to a user. Manipulation of the control **86** along the same direction **120** as previously performed but this time along directional indicator **108s** may nonetheless result in the imaged tissue **110**, as shown in FIG. 13B, being moved again in the same direction as shown in the imaged tissue **112** of FIG. 13C. In this example, the steering controls are constantly remapped such that tissue image as seen on the monitors always move in a direction that corresponds to the spatial orientation of the steering control **80**. This may be accomplished by utilizing, e.g., electronically-actuated mechanisms within handle assembly **80** which are controlled via a processor in communication with one or more accelerometers or position sensors. Such a system may automatically map and re-map the control **86** with the electronically-actuated mechanisms depending upon the orientation of the handle assembly **80** relative to an initially calibrated orientation.

**[0087]** In generating a representative image of the hood assembly orientation relative to the tissue surface, one or more sensors may be positioned along the catheter device for generating the images, as previously described, e.g., in U.S. patent application Ser. No. 11/848,532 filed Aug. 31, 2007 (U.S. Pat. Pub. 2009/0054803 A1), which has been previously incorporated herein by reference above. Additional sensors may be placed along the steerable sections of the catheter assembly such that an image of the relative positioning of the catheter and hood assembly may be generated for graphical representation. As shown in the perspective view of FIG. 14A, multiple sensors **121**, **122**, **124** may be positioned at intervals along the distal steerable section **52**. Additional sensors may also be positioned optionally along the proximal steerable section **54** as well. The resulting generated image **130** of the hood assembly **132** may be seen in FIG. 14B and the representative hood assembly **132** as well as the representative distal steerable section **134** may also be seen in the image of FIG. 14C. Providing the representative image of one or both steerable sections may provide the user the ability to observe the complex curve of the steerable sections for discerning if the catheter is at its contortion limit as the hood assembly is in proximity of the target tissue to allow for a faster and more intuitive movement of the catheter from one tissue region to another region without reaching contortion limits or oversteering the catheter assembly.

**[0088]** In yet another variation for facilitating tissue treatment, the captured visual image of the tissue as imaged through the hood **12** may be projected and mapped to the representative map of the tissue anatomy. Being able to visu-

alize the “active spot” **140** that is being visualized through the hood, shown by its representation **132**, by mapping it onto the surface of the representative three-dimensional model **130** may allow the physician to more accurately navigate the anatomy, as shown in FIG. **15A**. When visualizing and treating tissue using the visualization system, the catheter hood may not necessarily be visualizing the tissue that is seen on the in vivo visualization system. This may occur due to a variety of reasons such as non-perpendicularity of the hood to the tissue surface or contortion of the hood. Because the active spot moves as the catheter hood is being moved, this may give the physician a greater awareness and confidence on both the visualization systems.

[**0089**] The three-dimensional model **130** may be normally created by a sensor probe which is pushed against the walls of the anatomy. The associated data points are taken and a representative model is built. Often the model is inaccurate and physicians rely on approximations to make decisions on locations for tissue treatment. Cross-referencing the data points of the three-dimensional model with images viewed by the in vivo visualization system can be helpful in making adjustments and adding further detail to the model. Visual features such as pulmonary vein ostia could potentially be referenced to the three-dimensional model by location and contour matching software algorithms in addition to manual point selection.

[**0090**] In yet another example, way-pointing methods may also be utilized to facilitate tissue treatment by the physician. Way-pointing is a pre-operative method that allows the physician to map out the ablation procedure by selecting lesion sites on the three-dimensional model of the anatomy. As shown in the image model **130** of FIG. **15B**, one or more lesion sites, e.g., **142** to **152**, at least partially around the pulmonary vein PV ostium, may be pre-selected on the three-dimensional model **130**. This data may be then transmitted to the catheter system which may generate and project approximated lesion boundaries **162** to be formed as well as the navigational information **164** to guide the hood from one lesion to another as the procedure progresses, as shown in the direct visual image **160** captured through the hood **12** and projected on a monitor with the way-pointing and navigational information superimposed on the tissue image, as shown in FIG. **16A**. Such a way-pointing system may prevent the user from becoming disoriented in the anatomy of the heart and may effectively speed procedure times while ensuring that lesions are contiguously formed, if necessary or desired, by showing lesion boundaries.

[**0091**] Additionally and/or alternatively, other methods for helping the user to maintain spatial awareness of the surrounding tissue and anatomical features may also be utilized for facilitating navigation, safety, procedure efficacy, etc. FIG. **16B** shows an example of an imaged tissue region **170** with indicators of areas of interest beyond the field of view of the catheter hood. As an illustration, the pulmonary vein locations have been indicated in the figure but points of interest may also include unique anatomical features, locations of probes such as a probe positioned in the esophagus, location of the lung, patent foramen ovale, and among other things. The features to be displayed may be pre-selected on the three-dimensional visualization model prior to treatment. These points of interest may allow the user to establish a base of reference when they are viewing the images of tissue on the monitor. Additionally, the indication of surrounding tissue

regions may help to ensure the avoidance of inadvertently treating tissue treatment surrounding the tissue region of interest.

[**0092**] Yet another example for facilitating tissue treatment procedures may utilize the augmentation of images utilizing previously captured images. For instance, as shown in the three-dimensional model **180** of FIG. **17**, captured images **182**, **184**, **186**, **188** previously visualized through the hood and recorded may be compiled and stitched relative to one another to provide a seamless interior map of the anatomy. This image stitching may present an actual map of the interior of the heart instead of an approximate three-dimensional model. Moreover, the images can also be mapped such that they take on the contours of the model. Being able to see the actual visual inside the heart may increase physician confidence and also the speed of the procedure. Further examples and details are shown and described in U.S. patent application Ser. No. 11/848,532 filed Aug. 31, 2007 (U.S. Pat. Pub. 2009/0054803 A1), which has been previously incorporated herein above.

[**0093**] Procedure guidance systems are particularly useful when the user may be unfamiliar with the device and its capabilities or wish to facilitate the procedure by minimizing steering decisions from one ablation point to another. Such a system may function by first allowing the user to select potential ablation sites **192**, e.g., in proximity to a pulmonary vein PV ostium, on either a pre-operative three-dimensional model or on a uniquely generated three-dimensional model **190** as shown in FIG. **18A**. FIG. **18B** shows various idealized positions and orientations of the representation of the hood **194**, **196** in order to create optimal lesions taking into account the anatomical contours and structure. Physicians can then navigate the catheter hood into the particular orientation before performing ablation. Additionally, for steerable sections with a plurality of sensors, the steerable section can be graphically represented as well, as previously described. FIG. **18C** is an illustrative example of such a system in which the hood assembly **194** indicates the current position and the idealized hood assembly **196** represents the idealized position and orientation of the hood and the steerable section in order to perform the next ablation optimally.

[**0094**] FIG. **19** also shows a variation in which the handle assembly **80** may generate tactile sensations such as force feedback on the steering control **200** for providing force feedback to the user's hand **202** so that the user is prompted to steer the catheter into the most optimal and efficient manner to move from one location to another. Such a tactile sensation feature may be utilized with any of the variations described herein.

[**0095**] The applications of the disclosed invention discussed above are not limited to certain treatments or regions of the body, but may include any number of other treatments and areas of the body. Modification of the above-described methods and devices for carrying out the invention, and variations of aspects of the invention that are obvious to those of skill in the arts are intended to be within the scope of this disclosure. Moreover, various combinations of aspects between examples are also contemplated and are considered to be within the scope of this disclosure as well.

What is claimed is:

1. A method for assessing a tissue region of interest within a blood-filled environment, comprising:
  - visualizing the tissue region of interest through a purging fluid restrained temporarily within an open area defined

by a fluid barrier or membrane attached to a distal end of a catheter where the open area is in fluid communication with an environment external to the barrier or membrane;

projecting a computer generated model representative of the barrier or membrane onto a model representative of the tissue region of interest where the model of the barrier or membrane includes at least one directional indicator;

flashing the at least one directional indicator in response to at least one sensor being contacted on a handle assembly attached to a proximal end of the catheter where the at least one sensor is coordinated with the at least one directional indicator.

2. The method of claim 1 wherein visualizing the tissue region of interest comprises viewing an image of the tissue region upon a first monitor.

3. The method of claim 2 wherein projecting a computer generated model comprises viewing the model upon a second monitor.

4. The method of claim 1 wherein the model of the barrier or membrane includes at least four directional indicators.

5. The method of claim 4 wherein flashing comprises contacting at least one of four sensors on the handle assembly corresponding to the at least four directional indicators.

6. A method for navigating relative to a tissue region of interest within a blood-filled environment, comprising:  
 visualizing the tissue region of interest through a purging fluid restrained temporarily within an open area defined by a fluid barrier or membrane attached to a distal end of a catheter where the open area is in fluid communication with an environment external to the barrier or membrane; and,  
 rotating an image of the tissue region of interest upon a monitor such that a direction of articulation of a control on a handle assembly attached to a proximal end of the catheter is maintained whereby articulation of the control in a first direction articulates the image of the tissue region in a corresponding first direction regardless of an orientation of the handle assembly.

7. The method of claim 6 wherein visualizing the tissue region of interest comprises viewing an image of the tissue region upon a first monitor.

8. The method of claim 6 further comprising projecting a computer generated model representative of the barrier or membrane onto a model representative of the tissue region of interest.

9. The method of claim 6 wherein rotating further comprises calibrating an initial position of the handle assembly relative to a first position.

10. A method for assessing a tissue region of interest within a blood-filled environment, comprising:  
 visualizing the tissue region of interest through a purging fluid restrained temporarily within an open area defined

by a fluid barrier or membrane attached to a distal end of a catheter where the open area is in fluid communication with an environment external to the barrier or membrane;

projecting a computer generated model representative of the barrier or membrane onto a model representative of the tissue region of interest; and,  
 imposing an image of the tissue region visualized through the purging fluid upon the model representative of the tissue region of interest in proximity to the model representative of the barrier or membrane.

11. The method of claim 10 wherein visualizing the tissue region of interest comprises viewing an image of the tissue region upon a first monitor.

12. The method of claim 11 wherein projecting a computer generated model comprises viewing the model upon a second monitor.

13. The method of claim 10 further comprising imposing a plurality of adjacent images of the tissue region visualized through the purging fluid.

14. A method for navigating relative to a tissue region of interest within a blood-filled environment, comprising:  
 visualizing the tissue region of interest through a purging fluid restrained temporarily within an open area defined by a fluid barrier or membrane attached to a distal end of a catheter where the open area is in fluid communication with an environment external to the barrier or membrane; and,  
 projecting a computer generated model representative of the barrier or membrane onto a model representative of the tissue region of interest; and,  
 selecting one or more regions for treatment upon the model representative of the tissue region of interest; and  
 indicating directional information upon an image of the visualized tissue region of interest corresponding to the one or more regions selected for treatment.

15. The method of claim 14 wherein visualizing the tissue region of interest comprises viewing an image of the tissue region upon a first monitor.

16. The method of claim 15 wherein projecting a computer generated model comprises viewing the model upon a second monitor.

17. The method of claim 14 wherein selecting comprise selecting one or more regions to be ablated about a pulmonary vein ostium.

18. The method of claim 14 wherein indicating comprises indicating a region of tissue to be ablated upon the image.

19. The method of claim 18 further comprising indicating a distance to an adjacent region of tissue to be ablated upon the image.

20. The method of claim 14 further comprising indicating one or more anatomical landmarks in proximity to the tissue region of interest.

\* \* \* \* \*