



(86) Date de dépôt PCT/PCT Filing Date: 2005/11/17
 (87) Date publication PCT/PCT Publication Date: 2006/05/26
 (85) Entrée phase nationale/National Entry: 2007/05/15
 (86) N° demande PCT/PCT Application No.: GB 2005/004430
 (87) N° publication PCT/PCT Publication No.: 2006/054083
 (30) Priorité/Priority: 2004/11/19 (GB0425518.8)

(51) Cl.Int./Int.Cl. *G06M 1/16* (2006.01),
A61M 15/00 (2006.01), *B65D 83/14* (2006.01),
G06M 1/04 (2006.01), *G06M 1/22* (2006.01)

(71) Demandeur/Applicant:
 CLINICAL DESIGNS LIMITED, GB

(72) Inventeur/Inventor:
 BACON, RAYMOND, GB

(74) Agent: OGILVY RENAULT LLP/S.E.N.C.R.L.,S.R.L.

(54) Titre : **DISTRIBUTEUR DE SUBSTANCE**
 (54) Title: **SUBSTANCE SOURCE**

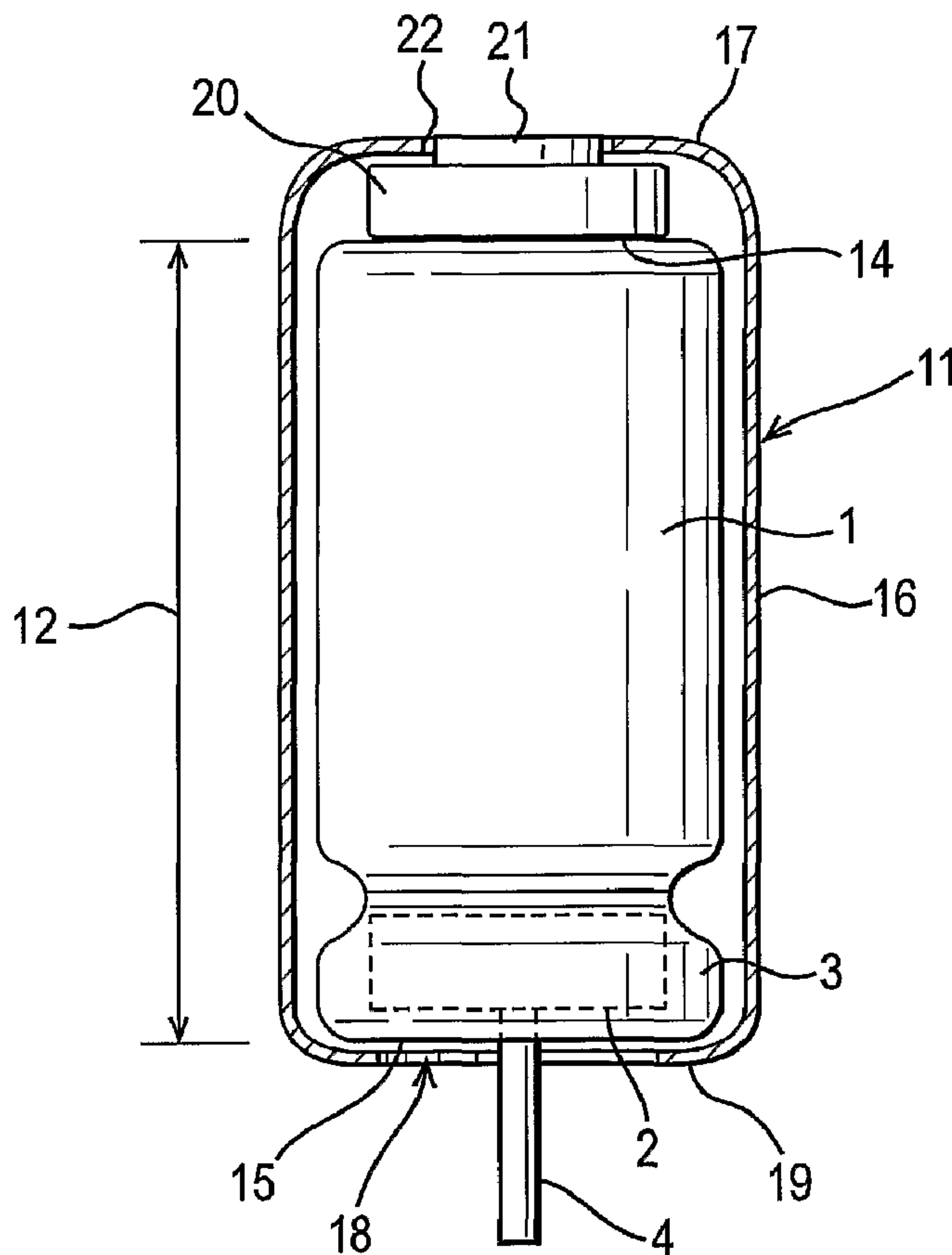

(57) **Abrégé/Abstract:**

A source of gaseous, gas borne or droplet substance having: an inner pressurised container (1), a substance-release valve (2) device sealed across an end of the container (1), a spout (4) displaceable inwards of the container (1) against a spring of the valve

(57) **Abrégé(suite)/Abstract(continued):**

(2) device for substance release; the source also includes: an outer enclosure enclosing the inner container along its length (12), at least partially its end (14) remote from the spout (4) and partially at its spout end (19), the outer enclosure ADN the inner container (1) being arranged to react force for displacement of the spout (4) on substance release; a counter (20) accommodated within the outer enclosure for counting substance release displacements of the spout (4); and a window (22) in the outer enclosure for viewing the count of the counter (20).

(12) INTERNATIONAL APPLICATION PUBLISHED UNDER THE PATENT COOPERATION TREATY (PCT)

(19) World Intellectual Property Organization
International Bureau



(43) International Publication Date
26 May 2006 (26.05.2006)

PCT

(10) International Publication Number
WO 2006/054083 A1

(51) International Patent Classification:

G06M 1/16 (2006.01) *A61M 15/00* (2006.01)
G06M 1/22 (2006.01) *B65D 83/14* (2006.01)
G06M 1/04 (2006.01)

(21) International Application Number:

PCT/GB2005/004430

(22) International Filing Date:

17 November 2005 (17.11.2005)

(25) Filing Language:

English

(26) Publication Language:

English

(30) Priority Data:

0425518.8 19 November 2004 (19.11.2004) GB

(71) Applicant (for all designated States except US): **CLINICAL DESIGNS LIMITED** [GB/GB]; Steep Farm, Steep, Petersfield, Hampshire GU32 2DB (GB).

(72) Inventor; and

(75) Inventor/Applicant (for US only): **BACON, Raymond** [GB/GB]; Steep Farm, Steep, Petersfield, Hampshire GU32 2DB (GB).

(74) Agent: **BROOKS, Nigel**; Hill Hampton, East Meon, Petersfield, Hampshire GU32 1QN (GB).

(81) Designated States (unless otherwise indicated, for every kind of national protection available): AE, AG, AL, AM, AT, AU, AZ, BA, BB, BG, BR, BW, BY, BZ, CA, CH, CN, CO, CR, CU, CZ, DE, DK, DM, DZ, EC, EE, EG, ES, FI, GB, GD, GE, GH, GM, HR, HU, ID, IL, IN, IS, JP, KE, KG, KM, KN, KP, KR, KZ, LC, LK, LR, LS, LT, LU, LV, LY, MA, MD, MG, MK, MN, MW, MX, MZ, NA, NG, NI, NO, NZ, OM, PG, PH, PL, PT, RO, RU, SC, SD, SE, SG, SK, SL, SM, SY, TJ, TM, TN, TR, TT, TZ, UA, UG, US, UZ, VC, VN, YU, ZA, ZM, ZW.

(84) Designated States (unless otherwise indicated, for every kind of regional protection available): ARIPO (BW, GH, GM, KE, LS, MW, MZ, NA, SD, SL, SZ, TZ, UG, ZM, ZW), Eurasian (AM, AZ, BY, KG, KZ, MD, RU, TJ, TM), European (AT, BE, BG, CH, CY, CZ, DE, DK, EE, ES, FI, FR, GB, GR, HU, IE, IS, IT, LT, LU, LV, MC, NL, PL, PT, RO, SE, SI, SK, TR), OAPI (BF, BJ, CF, CG, CI, CM, GA, GN, GQ, GW, ML, MR, NE, SN, TD, TG).

Published:

- with international search report
- before the expiration of the time limit for amending the claims and to be republished in the event of receipt of amendments

For two-letter codes and other abbreviations, refer to the "Guidance Notes on Codes and Abbreviations" appearing at the beginning of each regular issue of the PCT Gazette.

(54) Title: SUBSTANCE SOURCE

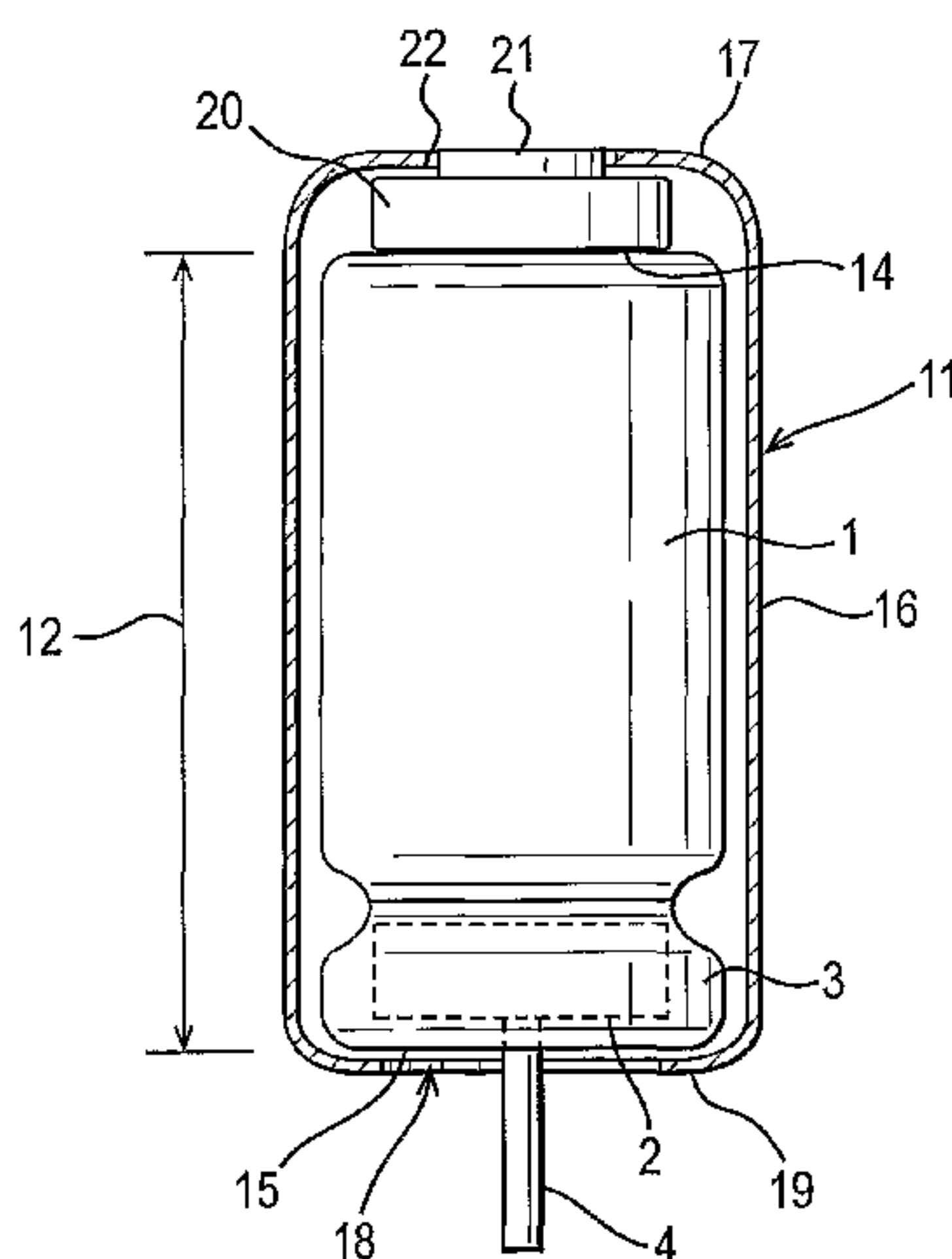

(57) Abstract: A source of gaseous, gas borne or droplet substance having: an inner pressurised container (1), a substance-release valve (2) device sealed across an end of the container (1), a spout (4) displaceable inwards of the container (1) against a spring of the valve (2) device for substance release; the source also includes: an outer enclosure enclosing the inner container along its length (12), at least partially its end (14) remote from the spout (4) and partially at its spout end (19), the outer enclosure and the inner container (1) being arranged to react to force for displacement of the spout (4) on substance release; a counter (20) accommodated within the outer enclosure for counting substance release displacements of the spout (4); and a window (22) in the outer enclosure for viewing the count of the counter (20).

WO 2006/054083 A1

SUBSTANCE SOURCE

Background of the Invention

The present invention relates to provided a source of a gaseous, gas borne or
5 droplet substance.

Such sources are used for dispensing medicaments in metered doses via a
dispenser. There is an increasing desire for the number of doses dispensed and/or left
in the source to be counted, so that a user can know the number of doses remaining
10 before a fresh source (and dispenser) is required.

The object of the present invention is to provide a substance source with an
integral counter.

15 The Invention

According to a first aspect of the invention there is provided a source of a
gaseous, gas borne or droplet substance having:

- an inner pressurised container,
- a substance-release valve device sealed across an end of the container,
- 20 • a spout displaceable inwards of the container against a spring of the valve
device for substance release,

the source also including:

- an outer enclosure enclosing the inner container along its length, at least
partially across its end remote from the spout and partially at its spout end,
- 25 • the outer enclosure and the inner container being arranged to react force
for displacement of the spout on substance release;
- a counter accommodated within the outer enclosure for counting substance
release displacements of the spout; and
- a window in the outer enclosure for viewing the count of the counter.

30

In certain embodiments, the counter is arranged at the end of the outer
enclosure, for reacting and counting occurrences of spout-displacement force from the
inner container to the outer enclosure. In particular where the substance is a high

value medicament, the counter can be a single use electronic counter. However, since an electronic counter is a relatively expensive component of a medicament source, in the preferred embodiment with such a counter, it can be a multi-use electronic counter, with the outer enclosure being provided with a frangible enclosure for the counter, whereby the counter can be removed from the medicament source by
5 breaking the enclosure when it is has reached its normal dose count limit, reset and installed on a fresh source using its fresh frangible closure. In this case, the counter provides the sole abutment for the inner container as regards spout-displacement force, whereby residual medicament cannot be used once the counter has been
10 removed.

Again, the counter can be a removable or an irremovable mechanical counter. The mechanical counter can include a dual set of ratchet teeth and pawls, with angular incrementation determined by the ratchet teeth and can be housed within the outer
15 enclosure and gearing is provided between an incremented ratchet disc and an indicator disc viewable through the window in the outer enclosure. This avoids unreliable dosing with the container being nearly empty.

In other embodiments, the counter is arranged to be incremented by
20 displacement of the spout. Normally such a counter will be a mechanical counter including a rotatable member indexed by one increment on each displacement of the spout.

Such a mechanical counter can include a dual set of ratchet teeth and pawls,
25 one of either of the teeth and the pawls being displaced with the spout the other being fast with the outer enclosure and the rotatable member being incremented partially by one of the dual set of teeth on inwards displacement of the spout and partially by the other of the dual set of teeth on return outwards displacement of the spout.

30 Alternatively, the mechanical counter can include a single set of ratchet teeth and at least one pawl and a frictional member restraining the rotatable member, one of either of the teeth and the pawls being displaced with the spout the other being fast with the outer enclosure and the rotatable member being incremented by the pawl and

teeth on inwards displacement of the spout and held by the frictional member on return outwards displacement of the spout.

In one of these embodiments:

- 5 • the rotatable member is a portion of the inner pressurised container or a sleeve fast with the container, the container or the sleeve being adapted to be indexed by one increment on each displacement of the spout,
- the said portion or sleeve has a helical track,
- the window extends axially and/or circumferentially of the outer enclosure and
- 10 • the source includes an indicator adapted to co-operate with the helical track for indicating movement along the extent of the window.

Alternatively:

- 15 • the rotatable member is a member internal of the outer enclosure, extending around the inner container and having a helical track,
- the window extends axially and/or circumferentially of the outer enclosure and
- the source includes an indicator adapted to co-operate with the helical track for indicating movement along the extent of the window.

20 In this alternative, the indicator can have:

- a curved inner face engaging the rotatable member, both at the track for movement of the indicator and laterally for location of the indicator and
- a flat outer face engaging the window with lateral extent for locating the indicator in the window circumferentially of the outer enclosure.

25

Again the indicator can have:

- a plain inner face engaging the helical track,
- a sprung outer face engaging the window and
- sides for locating the indicator in the window circumferentially of outer
- 30 enclosure and

the window is provided at a groove with sides co-operating with the sides of the indicator in locating the indicator circumferentially of the outer enclosure.

Thirdly, the indicator and the outer enclosure can have a complementary non-circular cross-section for locating the indicator in the window circumferentially of the outer enclosure.

5 It is possible for one of the sets of teeth and pawl(s) or the frictional member, whichever is provided, is arranged at the end of the inner member having the helical track remote from the spout and co-operates with the end of the outer enclosure on incrementing of the inner member. However, usually, both sets of teeth and pawls are provided at the spout end of the outer enclosure.

10

The member having the helical track can essentially comprise the helical track along the extent of the track and around the inner container and is resilient for movement of its spout end with the spout. However, usually, the member having the helical track comprises a circular cylindrical member around the inner container. The helical track itself can be a channel or groove in the cylindrical member. Alternatively, the helical track can be a rib or ridge on the cylindrical member.

15

In another feature, the member having the helical track, the indicator and the window are all adapted for plunging movement of the member and the indicator with the spout, a return spring being provided for return movement on outwards movement of the member and indicator after inwards, dispensing movement. Alternatively, the member having the helical track is axially located with respect to the outer enclosure and a separate member plungeable with respect to the outer enclosure is provided, the plungeable member being adapted for driving the helical track member in rotation.

25

Preferably, wherein the plungeable member is provided with:

- means for irrotationally locating it with respect to the outer enclosure and
- ones of the pawls or the teeth for rotationally driving the helical track member, the others of the teeth or the pawls being provided on the helical track member.

30

In this case, the pawls can be resilient axially of the helical track member for return of the plungeable member.

Alternatively the plungeable member can be provided with:

- the ones of the pawls or the teeth for rotationally driving the plungeable member, the outer enclosure being provided with the others of the teeth or the pawls,
- 5 • a plungeable connection with the helical track member for rotation thereof and
- a return spring for return movement of the plungeable member on outwards movement of the spout after inwards, dispensing movement.

Again, the helix of the helical track can be regular. Alternatively the helix of
10 the helical track can be less steep in its portion occupied by the indicator on initial use of the source and steeper in its portion indicating imminent exhaustion of the source.

In accordance with an importance feature, the source includes an end cap of the outer enclosure at its end remote from the spout, the end cap being connected to
15 an outer sleeve of the enclosure, at a position such that dispensing operation of the spout and incrementing operation of the counter are synchronised.

In accordance with a second aspect of the invention there is provided a source of a gaseous, gas borne or droplet substance an inner subassembly and an outer
20 subassembly,

- the inner subassembly having:
 - an inner pressurised container,
 - a substance-release valve device sealed across an end of the container,
 - a spout displaceable inwards of the container against a spring of the valve
25 device for substance release,
 - the inner subassembly having an overall length from the distal end of the spout to the remote end of the container, which length decreases on substance release and having at least:
 - a first quiescent length and
 - 30 • a second length at which the valve is opened for substance release;
- the outer subassembly having:
 - an outer enclosure at least partially enclosing the inner container along its length,

- an enclosure cap across the end of the enclosure remote from the spout and at least partially at its spout end,
 - the enclosure cap and the inner container being arranged to react force for displacement of the spout on substance release;
- 5 • a counter accommodated within the outer enclosure for counting substance release displacements of the spout; and
- a counter actuation member arranged beside the spout for displacement inwards to increment the counter
 - the outer subassembly having an overall length from the actuation
 - 10 member at the spout to a pressurised-container reaction surface, which length decreases on substance release and having at least:
 - a first quiescent length and
 - a second length at which counter incrementation is initiated,
 - the subassembly also having:
 - a tolerance adjusted connection of the cap to the outer enclosure set with
 - 15 respect to a use installation of the source, whereby the stroke between the first and second lengths of the respective assemblies is compensated for synchronisation of substance release and count incrementation.

20 According to a third aspect of the invention, there is provided a dispenser for a gaseous, gas borne or droplet substance, the dispenser comprising:

- a source of the first or second aspect;
 - a mouth piece in connected to the outer enclosure;
 - a junction member receiving the spout of the source;
 - 25 • a nozzle connected to the junction member and arranged to direct a dose of the substance out through the mouth piece; and
- means for actuating the dispenser to dispense the dose and increment the counter.

30 Normally the valve mechanism will be a metered dose valve mechanism.

Drawings

To help understanding of the invention, a specific embodiment thereof will now be described by way of example and with reference to the accompanying drawings, in which:

Figure 1 is a partially sectioned side view of a first medicament source
5 according to the invention;

Figure 2 is a top end view of the source of Figure 1;

Figure 3 is a view similar to Figure 1 of a second source of the invention;

Figure 4 is a top view of the source of Figure 3;

Figure 5 is a side view of a third source of the invention;

10 Figure 6 is a top view of the source of Figure 4;

Figure 7 is a more detailed view of the mechanical counter of the third source;

Figure 8 is a sectional view on the line VII-VII in Figure 7 of the epicyclic gearbox of the counter of Figure 7;

Figure 9 is side partially sectioned side view of a fourth source of the
15 invention;

Figure 10 is a plain side view of the fourth source;

Figure 11 is a partially sectioned side view of a first variant of the fourth
source;

Figure 12 is a similar view of a second variant of the fourth source;

20 Figure 13 is a side view of a fifth source of the invention;

Figure 14 is a cross-sectional side view of the fifth source;

Figure 15 is a cross-sectional plan view of the fifth source;

Figure 16 is a scrap view of the teeth and pawls of the fifth source;

Figure 17 is a cross-sectional side view of a sixth source;

25 Figure 18 is a scrap view of a plunging connection the sixth source;

Figure 19 is a side view of the sixth source;

Figure 20 is a cross-sectional side view of a dispenser of the invention; and

Figure 21 is a cross-sectional plan view of the dispenser of Figure 20.

30 First Preferred Embodiment

In the first embodiment, the medicament source shown in Figures 1 & 2 has:

- an inner pressurised container 1 of stamped aluminium,

- a substance-release valve device 2 sealed across an end of the container by means of a crimp cap 3,
- a spout 4 displaceable inwards of the container against a spring (not shown) of the valve device for release substance.

5 These features are conventional.

In accordance with the invention, the source also includes an outer sleeve 11 enclosing the inner container along its length 12, across its end 14 remote from the spout and at least partially at its spout end 15. In this embodiment, the sleeve also is
10 of stamped aluminium, with a circularly cylindrical body 16, a closed end 17 and an open end 18 at which it has a turned-in rim 19, captivating the inner container in the outer sleeve by engagement under the crimp cap. Only the spout 4 extends from the outer sleeve.

15 Between the end 14 of the inner container opposite from the spout 4 and the end 17 of the outer sleeve is accommodated an electronic counter 20, of the type which increments or more precisely decrements each time a compressive force is applied across it. The counter per se is of a known type. It has a display 21 aligned with a window 22 in the end 17 of the outer sleeve.

20

In use, with the spout received in the junction member of an inhaler body (not shown), pressure on the end 17 of the outer sleeve urges it and the inner container down, with the spout being pushed inwards and causing the valve to release a dose through the junction member.

25

The force to actuate the valve is transmitted from the outer sleeve to the inner container via the counter, which decrements its display. Thus the user can monitor how many doses remain in the source by viewing the display through the window 22.

30 Second Embodiment

Turning now to a second embodiment shown in Figures 3 & 4, whilst the previous embodiment is suitable for high value medicaments, it is not suitable for low value medicaments where the counter may be the most expensive component

including the medicament. In this embodiment, the counter 101 is removable and equipped with a switch 102 which turns on the counter only when pressed in and resets the counter in doing so.

5 Whereas the outer sleeve 103 of the first embodiment is of aluminium, that of the second embodiment is a two part plastics material moulding, suitably of polypropylene. It comprises a sleeve component 104 and an end cap component 105. They have complementary formations 106, 107 for clipping the cap onto the sleeve. The latter is circularly cylindrical, with a turned in lower rim 108 and internal
10 formations 109 for clipping into the crimp neck 6 of the inner container, which is identical to that of the first embodiment – hence use of the same reference numerals in this respect. The formations discourage removal of the sleeve, but are provided with clearance from the crimp neck, whereby actuation for medicament dispensing always results in dispensing force application to the sleeve via the counter 101. The sleeve is
15 of sufficient length to discourage use of the source without the cap 105 fitted, in that the end 14 of the inner container is not readily accessible through the open end of the sleeve.

 With a counter 101 fitted in the open end and the cap 105 fitted, the end 14 of
20 the inner container abuts against the counter and the counter abuts against the cap, at least on pressure on the cap for use of the source. Fitting of the counter and cap has switched on the counter, whose display is visible through a window 110 in the cap. Pressing on the cap 105 or indeed the counter via its window results in (1) force being transmitted to the inner container for valve actuation and dose dispensing and (2) the
25 dispensing act being counted.

 The sleeve formation 106 has a groove on the outer surface of the sleeve and the cap formation 107 has an inwards-facing rim on tear-off, annular strip 111. When the source is exhausted, the strip is torn off, the counter removed for use with a new
30 source and the rest of the source is discarded.

Third Embodiment

 Turning now a third embodiment, shown in Figures 5 to 8, the outer sleeve 203 is also a two part component, comprising a sleeve part 204 and a cap which is

longer to accommodate a mechanical counter 201, which is deeper than its electronic counterpart. It has an inner-container engagement member 2011, with a recess 2012 for tightly receiving the container end 14 and three resilient pawl members 2013 which curve shallowly curve around and away from the spout. They engage a rotary ratchet member 2014 with oppositely directed ratchet teeth 2015, 2016 on its bottom and top faces. The teeth 2015 are complementary to the pawl members 2013, whilst the teeth 2016 are complementary to rigid pawl teeth 2017 on the cap 205. It is anticipated that that the member 2011 will be held against rotation by the spout 4 of the container 1; however, if need be it can be splined to the sleeve part 204. Dispensing of a dose causes the pawl members to drive the ratchet member around with the teeth 2016, 2017 riding over each other by one pitch. On release of the dispensing force, the pawl members maintain the engagement of the teeth 2016, 2017 in their new position.

To allow a count of 200 doses requires a circle of 200 ratchet teeth. This is difficult to achieve with an inner container of 23mm, a typical size, since the pitch of the teeth is:

$$23 \times 3.14 / 200 = 0.36\text{mm.}$$

In this embodiment the teeth are set at a greater pitch, but there are less of them. Their effect is modified by an epicyclic gearbox 2020. This comprises a sun wheel 2021 integral with the ratchet member 2014. It is arranged within an annular gear 2022 moulded integrally with the cap 205, with its teeth set inwards from the upper ratchet teeth 2016. Three planet wheels 2023 having central bores 2024 are arranged between the sun wheel and the annular wheel. As the ratchet member and with it the sun wheel is ratcheted around, the planet wheels roll around with it. With a comparatively small sun wheel, several turns of it are required for complete traverse of the planet wheels around the gearbox. A carrier 2025 has pins 2026 which extend down into the bores of the planet wheels. On its top surface, the carrier has graduations visible through a window 2027 in the end cap. Thus the number of doses used/remaining can be determined by viewing the graduations, which successively pass the window.

Fourth Embodiment

Turning on now to the fourth embodiment of Figures 9 and 10, the source there shown has an outer sleeve 303 of aluminium, with a slot 330 extending along the greater part of its length. Immediately within the sleeve is a secondary sleeve 331 with a helical groove 332. An indicator 333 in the form of a disc with studs on either side engages with its studs in the slot and the groove. Thus as the secondary sleeve is turned, the indicator is moved along the slot. The helix is uneven, being steeper at the spout end of the outer sleeve, where initial doses show only small movement of the indicator, whereas dispensing of the final doses causes faster movement of the indicator.

10

The secondary sleeve is moved in a manner akin to the ratchet member of the preceding embodiment. At the spout end of the outer sleeve, it is crimped onto a guide member 334 having three short longitudinal grooves 335, which guide a yoke 336, having fingers 337 extending into the grooves. The ends of the grooves are closed 338 to captivate the yoke. The upper ends of the grooves are closed by projections 339 that extend to the crimp cap of the inner container, locating it within the outer sleeve. The yoke has a central bore 340 for the spout 4 and three resilient pawl members 341, which are spaced between the projections 339. The pawl members extend up to engage with teeth 342 provided on the bottom edge of the secondary sleeve. The top edge of this sleeve also has teeth 343, which co-operate with fixed pawl teeth 344 on a cap 345 crimped to the outer sleeve.

15

20

In use, the source is mounted in a dispenser body (not shown except for a junction J), with the spout engaged in a junction member. Depression of the source towards the junction member pushes the spout into the valve and the yoke also towards the valve. The flexible pawls 341 are permanently engaged with the lower teeth 342, whatever the position of the yoke, and as the yoke is urged in towards the inner container, the pawls foreshorten, rotating the secondary sleeve. The upper teeth are indexed across the fixed pawl teeth. As the source is allowed to return after dispensing its dose, the resilient pawls continue to urge the secondary sleeve up against the fixed pawls, with the result that the sleeve is held against rotation. The resilient pawls ride over the lower teeth, setting themselves for the next dispensing action. On successive actions, the secondary sleeve moves progressively round, driving the indicator down the slot 330 as described above.

25

30

A first variant of the fourth embodiment, as shown in Figure 11 has distinct similarities to the previous embodiments, save that the function of the helical groove in the secondary sleeve is performed by a helical groove 432 impressed in the wall of the inner container. The function of the upper teeth and the fixed pawls is performed by an elastomeric ring 444 pushed into an outer-sleeve cap 445. Then the function of the lower ratchet teeth is performed by teeth 442 impressed into the crimp cap 3 of the inner container. The resilient pawls 441 act on the teeth 442, progressively rotating the inner container with respect to the outer sleeve and driving an indicator 433 along a slot 430 in the outer sleeve.

The second variant, shown in Figure 12, differs in that the yoke 546 is rotatably carried on the spout. The yoke is fast with a helical member 550, which is formed as a progressively tighter winding. It carries an indicator 533, co-operating with a slot 530 in an outer sleeve. The helical member abuts against the closed end of the outer sleeve, to urge the yoke permanently downwards. The outer sleeve is crimped to a two part yoke drive member 534. The two parts 5341, 5342 have oppositely directed ratchet teeth 5343, 5344, with face each other in positions that would be interdigitated if they were not spaced from each other. The yoke has a set of fingers 537 which are arranged between these teeth.

As the source is depressed and the spout is driven inwards, the yoke is urged inwards against the resilience of the helical member. The fingers 537 slide along the faces of the upper teeth 5341 and rotate the helical member. As the spout is released, the fingers move back and engage the lower teeth 5342, further rotating the helical member. The result is that the fingers come to rest indexed one by one pitch of the upper teeth – and indeed one pitch of the lower teeth – ready for the next depression of the spout.

In a non-illustrated embodiment, the moulded plastics material helix of Figure 12 can be replaced by a spring wire helix.

Fifth Embodiment

Turning now to the fifth embodiment, shown in Figures 13 to 16, the source there shown has a pressurised container 1, with a spout 4. As shown, the upper part of the container is visible through an outer sleeve 611 of transparent plastics material. This has a flat window 612, through which an indicator 613 can be viewed. The indicator has a flat front face 614, which abuts the flat inside of the window. Rear face 615 of the indicator is curved to match the curvature of a helically grooved inner member 616. The indicator has a rear protrusion 617 into the groove 618. This arrangement not only connects the indicator to the groove, but also prevents the indicator from turning about the protrusion due to the curvature of the rear face. Further, the indicator is restrained from moving along the groove. Such movement would involve the front face 614 moving out of alignment with the window. However, again the curved rear face restrains such movement.

The pitch of the groove 618 is small at the end of the inner member remote from the spout, but increases at the spout end to alert the user that a new source will shortly be required. The arrangement for indexing the inner member 616 is a series of triangular teeth 619 moulded on the inside of the outer sleeve and a pair of oppositely directed flexible pawl arms 620 with pawl elements 621 at their distal end moulded in a cut out 622 in the inner member. A rigid pawl member 623 and a rigid locator notch 624 are provided. In use, the pawl element on the spout side of the teeth 619 makes initial contact with a tooth, followed by contact by the pawl 623 with the neighbouring tooth. Continued movement of the inner brings a parallel portion of the rigid pawl between these two teeth. On return movement, the other flexible pawl continues the indexing movement which is completed by the next tooth coming to rest in the notch 624. This movement is initiated by a junction member, not shown, in which the spout 4 is received, abutting an in-turned rim 625 of the inner member, whereby depression of the container 1 and with it the outer sleeve 611 and its teeth 619 releases a dose from the spout and performs the first part of the indexing as described. A return spring 626 is provided between the rim 625 and the crimp cap 3 of the container.

Other details of the source are that outer sleeve has a clipped on rim 627 outside the inner rim 625 at the spout end. Further the sleeve has an end cap 628 welded on at 629 to close the other end of the sleeve and locate the container axially

with respect to the sleeve. The relative position of the container and the sleeve are important, because the spout co-operates with elastomeric parts, the tolerance of whose position with respect to the cap 3 and the body of the container 1 is not tight. The result is the possibility of the release of the dose not being synchronised with the
5 incrementing of the counter. In other words either may occur without the other. This can be avoided by arranging the relative quiescent position of the spout and the rim such that on inwards movement of the stem to its release position, the inner member is stroked to its indexing position. This is achieved by (1) measuring the overall length of the container and spout in quiescent state from the spout's distal end to the
10 container's remote end and (2) welding the end cap 628 to the sleeve with a consequently determined length between the outer face of the rim 625 and outer face of the end cap with the rim not yet fitted. The result is that with the spring 626 holding the container 1 against the end cap 628 and the inner member against the teeth 619, both at the notch 624 and other corresponding abutments 630 around the
15 member 616, the spout protrudes with a determined amount from the rim 625. Synchronisation of dose release and indexing are thus achieved.

Sixth Embodiment

The sixth embodiment of Figures 17 to 19 differs in a few but significant
20 details. Its inner member 716 is axially located with respect to the outer sleeve 711 by means of a bead 751 on the inner member engaging in a groove 752 in the outer sleeve. A plunging extension 753 of the inner member, having its rim 725 with the spout 4 passing through it and the inner members pawls (not shown), has fingers 754 in plunging mesh with fingers 755 on the inner member 716. Thus dispensing action
25 plunges the extension 753 only with respect to the outer sleeve 711 without plunging of the marker as occurs in the fifth embodiment.

The marker 756 is guided in a helical channel 757 extending both along and around the outer sleeve, providing enhanced opportunity of accurate graduation (not
30 shown). It has a pip (not shown) on its back side and two fingers 758, which are resilient and extend outwards when free, which urge the marker into engagement with the helical channel. It has a central mark 759

Seventh Embodiment

The seventh embodiment of Figures 20 & 21 differs in that the source integrally includes a mouthpiece 801 and an actuation button 802, including a junction 803 receiving the spout 4 and having a nozzle 804 directed out of the mouth piece.

5

The mouthpiece is moulded in a piece 805 fitted in place of the clipped on rim 627 of the fifth embodiment. The moulding 805 has an aperture 806 in which the button 802 is received.

10

A further difference is that whilst the inner member 816 is circularly cylindrical, the outer sleeve 811 is non-circular. The marker 856 is formed as a stirrup around the inner member and is restrained from moving around it by having a shape complementary to the outer sleeve.

CLAIMS:

1. A source of a gaseous, gas borne or droplet substance having:
 - an inner pressurised container,
 - a substance-release valve device sealed across an end of the container,
 - 5 • a spout displaceable inwards of the container against a spring of the valve device for substance release,the source also including:
 - an outer enclosure enclosing the inner container along its length, at least partially across its end remote from the spout and partially at its spout end,
 - 10 • the outer enclosure and the inner container being arranged to react force for displacement of the spout on substance release;
 - a counter accommodated within the outer enclosure for counting substance release displacements of the spout; and
 - a window in the outer enclosure for viewing the count of the counter.
- 15 2. A source as claimed in claim 1, wherein the counter is arranged at the end of the outer enclosure, for reacting and counting occurrences of spout-displacement force from the inner container to the outer enclosure.
3. A source as claimed in claim 2, wherein the counter is a single use electronic counter.
- 20 4. A source as claimed in claim 2, wherein the counter is a multi-use electronic counter, and the outer enclosure is provided with a frangible enclosure for the counter, whereby the counter can be removed from the medicament source by breaking the enclosure when it is has reached its normal dose count limit, reset and installed on a fresh source using its fresh frangible closure.
- 25 5. A source as claimed in claim 4, wherein the counter provides the sole abutment for the inner container as regards spout-displacement force, whereby residual medicament cannot be used once the counter has been removed.
6. A source as claimed in claim 2, wherein the counter is a removable mechanical counter.
- 30 7. A source as claimed in claim 2, wherein the counter is an irremovable mechanical counter.

8. A source as claimed in claim 6 or claim 7, wherein the mechanical counter includes a dual set of ratchet teeth and pawls, with angular incrementation determined by the ratchet teeth.

9. A source as claimed in claim 8, wherein the counter is housed within the outer enclosure and gearing is provided between an incremented ratchet disc and an indicator disc viewable through the window in the outer enclosure.

10. A source as claimed in claim 1, wherein the counter is arranged to be incremented by displacement of the spout.

11. A source as claimed in claim 10, wherein the counter includes a rotatable member indexed by one increment on each displacement of the spout.

12. A source as claimed in claim 11, wherein the mechanical counter includes a dual set of ratchet teeth and pawls, one of either of the teeth and the pawls being displaced with the spout the other being fast with the outer enclosure and the rotatable member being incremented partially by one of the dual set of teeth on inwards displacement of the spout and partially by the other of the dual set of teeth on return outwards displacement of the spout.

13. A source as claimed in claim 11, wherein the mechanical counter includes a single set of ratchet teeth and at least one pawl and a frictional member restraining the rotatable member, one of either of the teeth and the pawls being displaced with the spout the other being fast with the outer enclosure and the rotatable member being incremented by the pawl and teeth on inwards displacement of the spout and held by the frictional member on return outwards displacement of the spout.

14. A source as claimed in claim 11, claim 12 or claim 13, wherein:

- the rotatable member is a portion of the inner pressurised container or a sleeve fast with the container, the container or the sleeve being adapted to be indexed by one increment on each displacement of the spout,
- the said portion or sleeve has a helical track,
- the window extends axially and/or circumferentially of the outer enclosure and
- the source includes an indicator adapted to co-operate with the helical track for indicating movement along the extent of the window.

15. A source as claimed in claim 11, claim 12 or claim 13, wherein:

- the rotatable member is a member internal of the outer enclosure, extending around the inner container and having a helical track,

- the window extends axially and/or circumferentially of the outer enclosure and
- the source includes an indicator adapted to co-operate with the helical track for indicating movement along the extent of the window.

16. A source as claimed in claim 15, wherein the indicator has:

- 5
- a curved inner face engaging the rotatable member, both at the track for movement of the indicator and laterally for location of the indicator and
 - a flat outer face engaging the window with lateral extent for locating the indicator in the window circumferentially of the outer enclosure.

17. A source as claimed in claim 15, wherein the indicator has:

- 10
- a plain inner face engaging the helical track,
 - a sprung outer face engaging the window and
 - sides for locating the indicator in the window circumferentially of outer enclosure and

15 the window is provided at a groove with sides co-operating with the sides of the indicator in locating the indicator circumferentially of the outer enclosure.

18. A source as claimed in any one of claims 15 to 17, wherein the indicator and the outer enclosure have a complementary non-circular cross-section for locating the indicator in the window circumferentially of the outer enclosure.

19. A source as claimed in any one of claims 12 to 18, wherein one of the sets of teeth and pawl(s) or the frictional member, whichever is provided, is arranged at the end of the inner member having the helical track remote from the spout and co-operates with the end of the outer enclosure on incrementing of the inner member.

20. A source as claimed in claim 12 or any one of claims 14 to 18, wherein both sets of teeth and pawls are provided at the spout end of the outer enclosure.

25 21. A source as claimed in any one of claims 15 to 20, wherein the member having the helical track essentially comprises the helical track along the extent of the track and around the inner container and is resilient for movement of its spout end with the spout.

22. A source as claimed in any one of claims 15 to 20, wherein the member having the helical track comprises a circular cylindrical member around the inner container.

23. A source as claimed in claim 22, wherein the helical track is a channel or groove in the cylindrical member.

24. A source as claimed in claim 22, wherein the helical track is a rib or ridge on the cylindrical member.

25. A source as claimed in claim 22, claim 23 or claim 24, wherein the member having the helical track, the indicator and the window are all adapted for plunging
5 movement of the member and the indicator with the spout, a return spring being provided for return movement on outwards movement of the member and indicator after inwards, dispensing movement.

26. A source as claimed in claim 22, claim 23 or claim 24, wherein the member having the helical track is axially located with respect to the outer enclosure and a
10 separate member plungeable with respect to the outer enclosure is provided, the plungeable member being adapted for driving the helical track member in rotation.

27. A source as claimed in claim 26, wherein the plungeable member is provided with:

- means for irrotationally locating it with respect to the outer enclosure and
- 15 • ones of the pawls or the teeth for rotationally driving the helical track member, the others of the teeth or the pawls being provided on the helical track member.

28. A source as claimed in claim 27, wherein the pawls are resilient axially of the helical track member for return of the plungeable member.

20 29. A source as claimed in claim 26, wherein the plungeable member is provided with:

- the ones of the pawls or the teeth for rotationally driving the plungeable member, the outer enclosure being provided with the others of the teeth or the pawls,
- 25 • a plungeable connection with the helical track member for rotation thereof and
- a return spring for return movement of the plungeable member on outwards movement of the spout after inwards, dispensing movement.

30. A source as claimed in any one of claims 14 to 29, wherein the helix of the helical track is regular.

30 31. A source as claimed in any one of claims 14 to 29, wherein the helix of the helical track is less steep in its portion occupied by the indicator on initial use of the source and steeper in its portion indicating imminent exhaustion of the source.

32. A source as claimed in any preceding claim, including an end cap of the outer enclosure at its end remote from the spout, the end cap being connected to an outer sleeve of the enclosure, at a position such that dispensing operation of the spout and incrementing operation of the counter are synchronised.

5 33. A source of a gaseous, gas borne or droplet substance an inner subassembly and an outer subassembly,

- the inner subassembly having:
 - an inner pressurised container,
 - a substance-release valve device sealed across an end of the container,
 - 10 • a spout displaceable inwards of the container against a spring of the valve device for substance release,
 - the inner subassembly having an overall length from the distal end of the spout to the remote end of the container, which length decreases on substance release and having at least:
 - 15 • a first quiescent length and
 - a second length at which the valve is opened for substance release;
- the outer subassembly having:
 - an outer enclosure at least partially enclosing the inner container along its length,
 - 20 • an enclosure cap across the end of the enclosure remote from the spout and at least partially at its spout end,
 - the enclosure cap and the inner container being arranged to react force for displacement of the spout on substance release;
 - a counter accommodated within the outer enclosure for counting
 - 25 substance release displacements of the spout; and
 - a counter actuation member arranged beside the spout for displacement inwards to increment the counter
 - the outer subassembly having an overall length from the actuation member at the spout to a pressurised-container reaction surface, which
 - 30 length decreases on substance release and having at least:
 - a first quiescent length and
 - a second length at which counter incrementation is initiated,
- the subassembly also having:

- a tolerance adjusted connection of the cap to the outer enclosure set with respect to a use installation of the source, whereby the stroke between the first and second lengths of the respective assemblies is compensated for synchronisation of substance release and count incrementation.
- 5 34. A dispenser for a gaseous, gas borne or droplet substance, the dispenser comprising:
- a source as claimed in any preceding claim;
 - a mouth piece in connected to the outer enclosure;
 - a junction member receiving the spout of the source;
 - 10 • a nozzle connected to the junction member and arranged to direct a dose of the substance out through the mouth piece; and
 - means for actuating the dispenser to dispense the dose and increment the counter.

1/12

FIG. 1

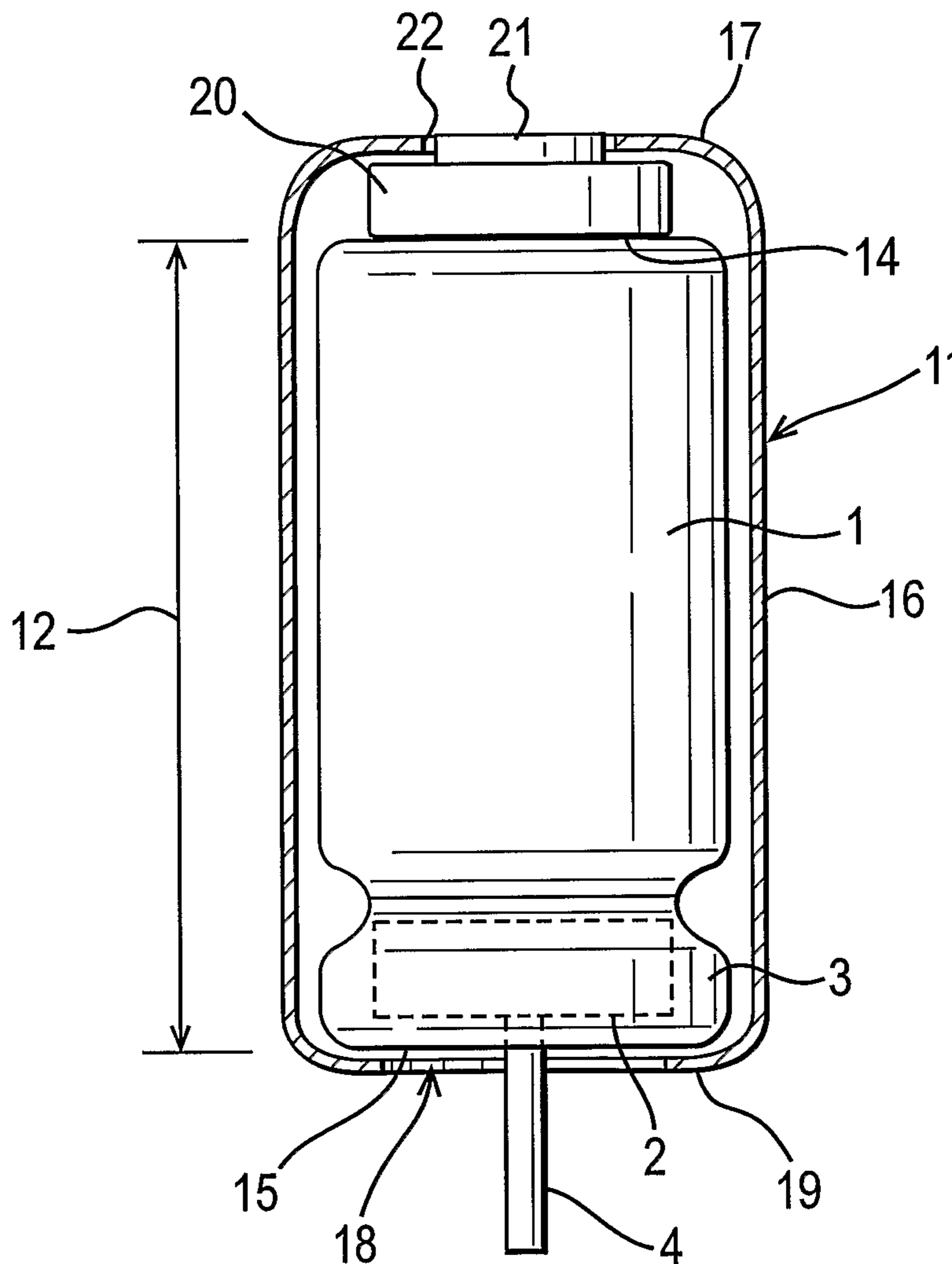

FIG. 2

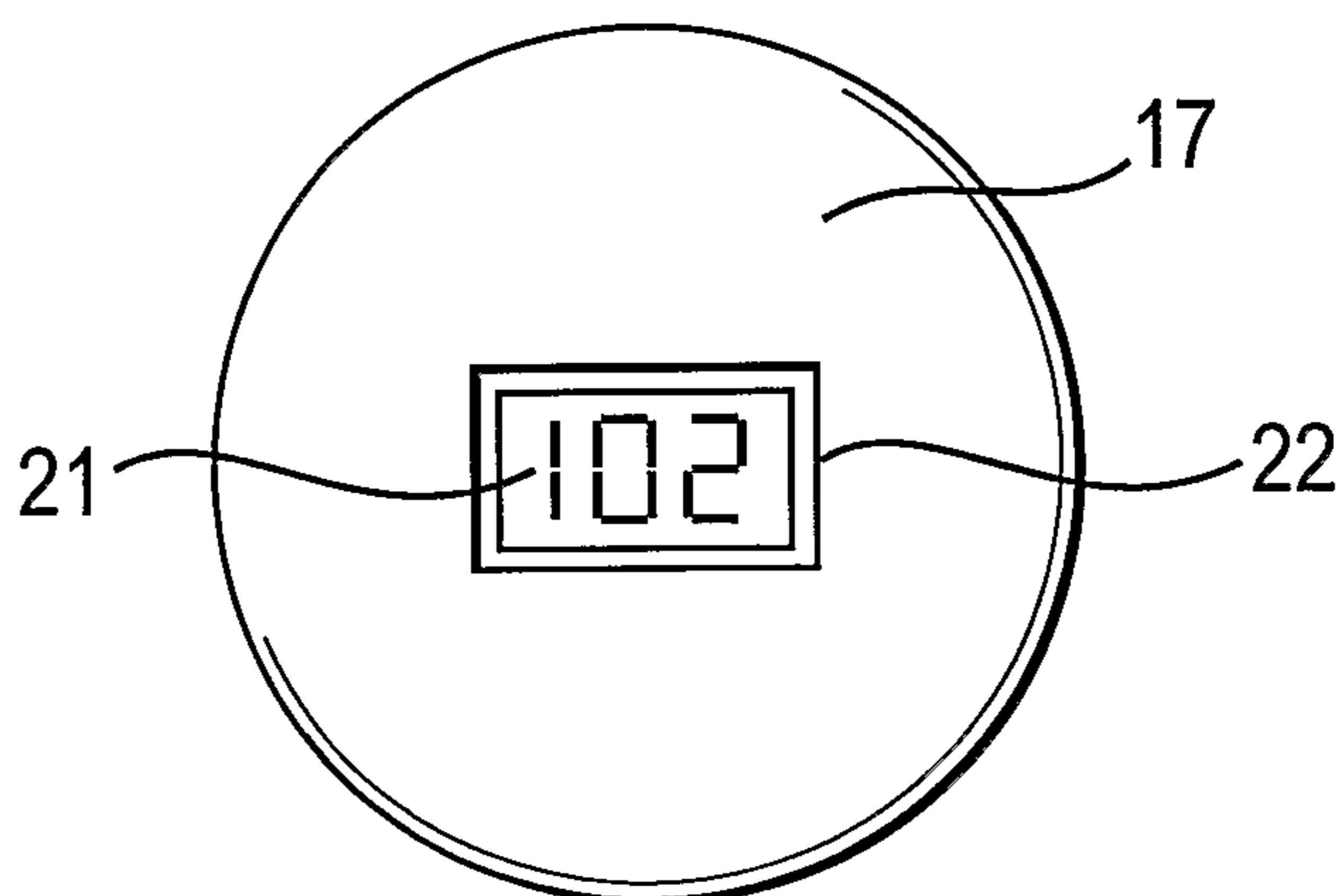

FIG. 3

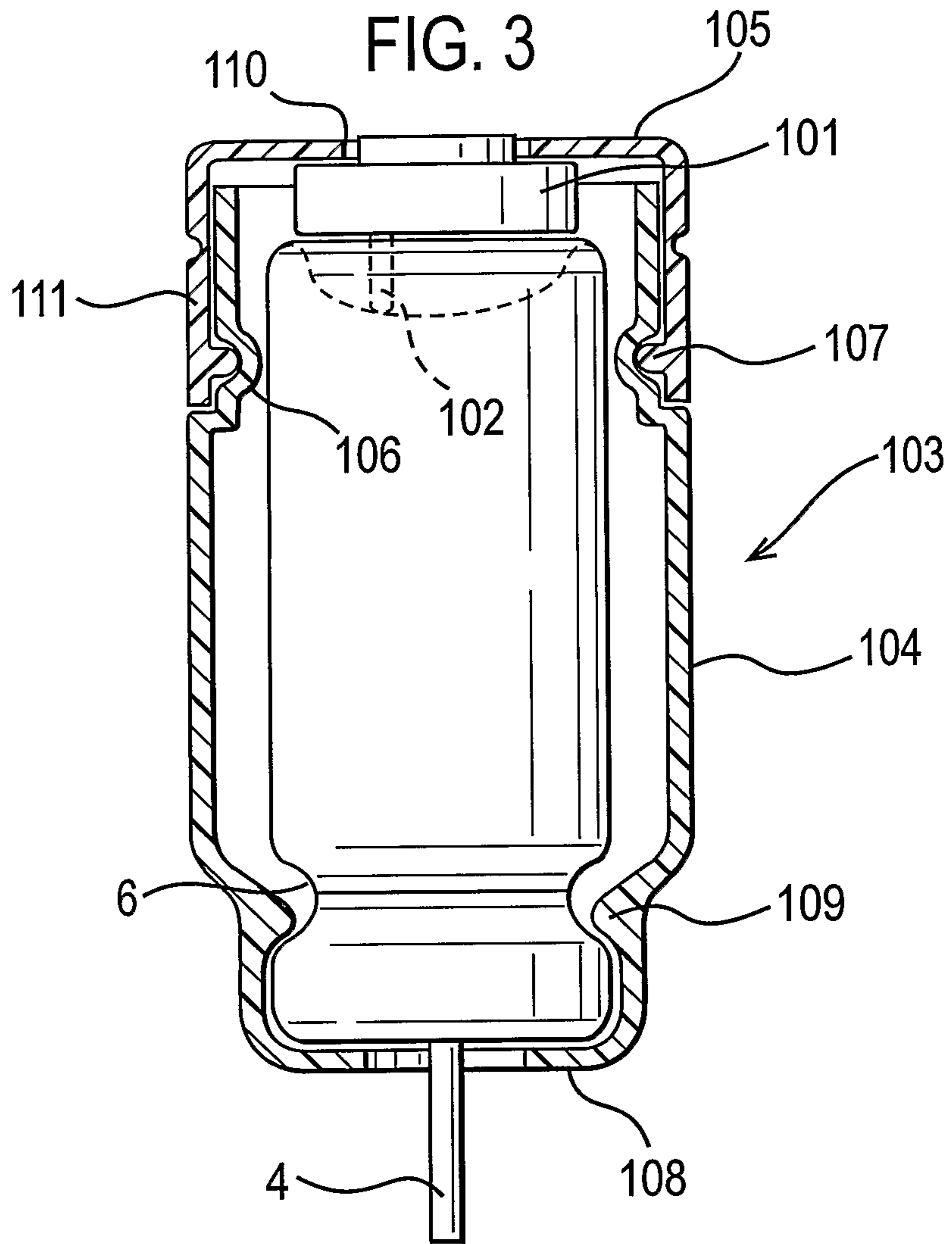
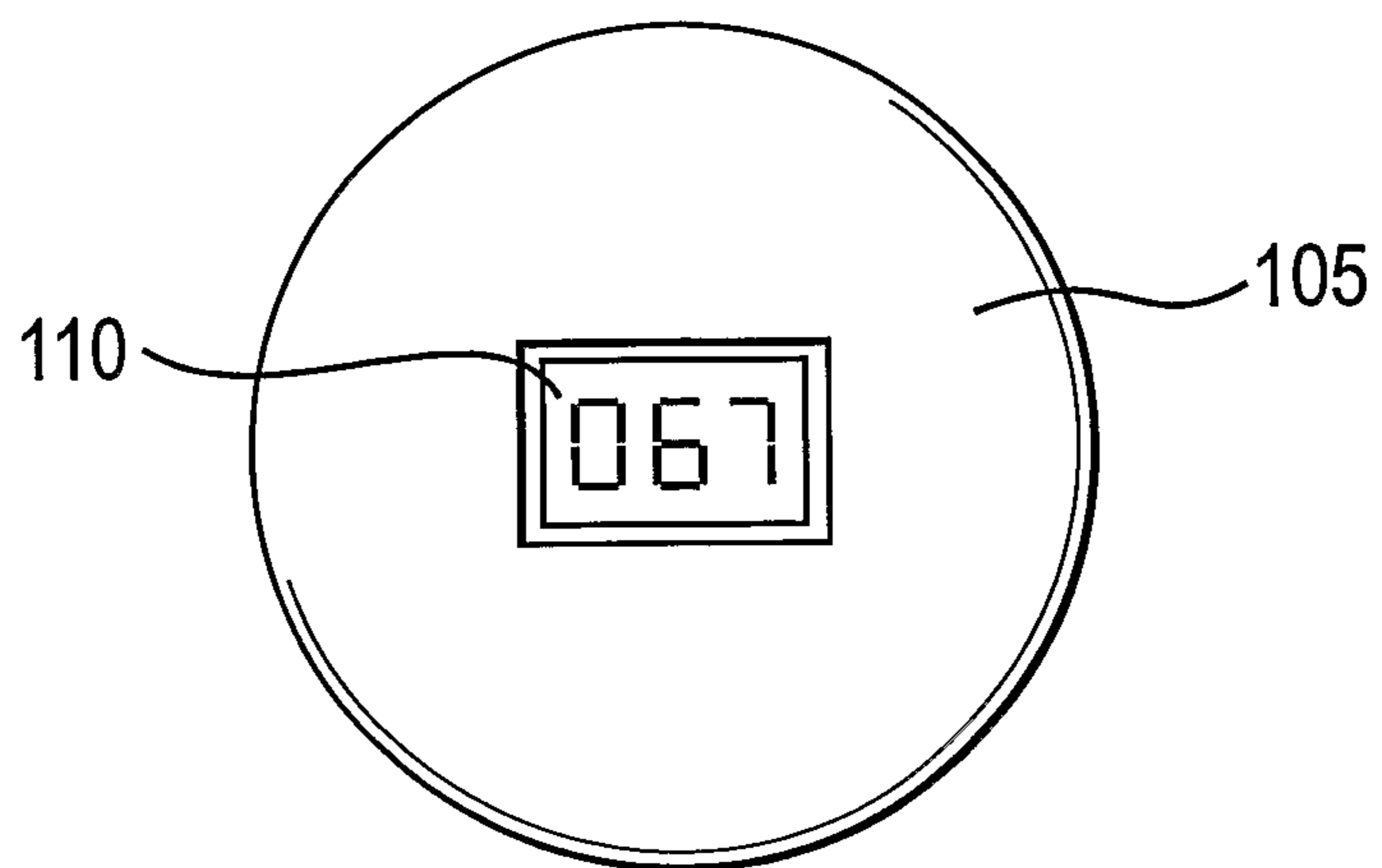

FIG. 4



3/12

FIG. 5

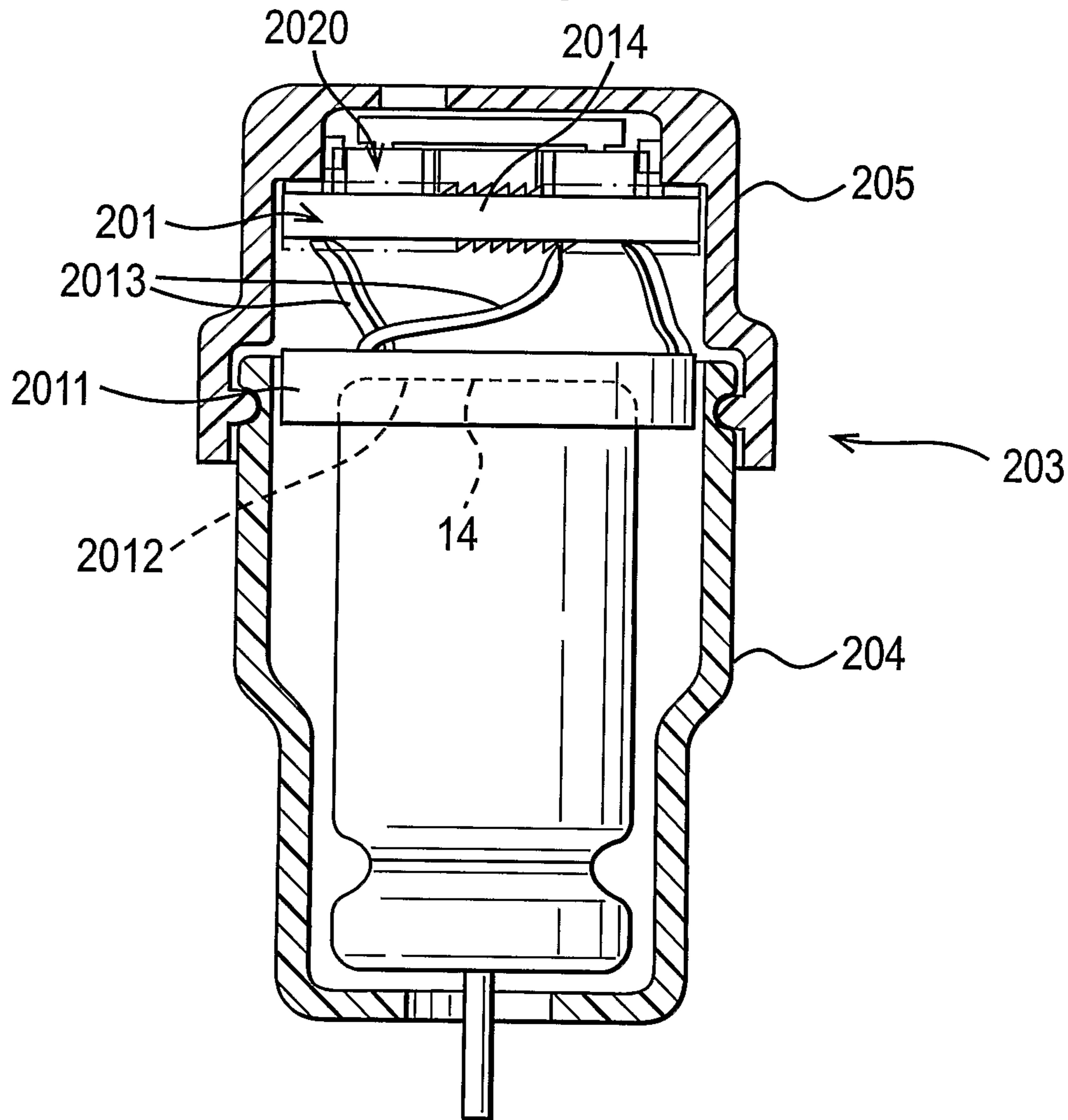

FIG. 6

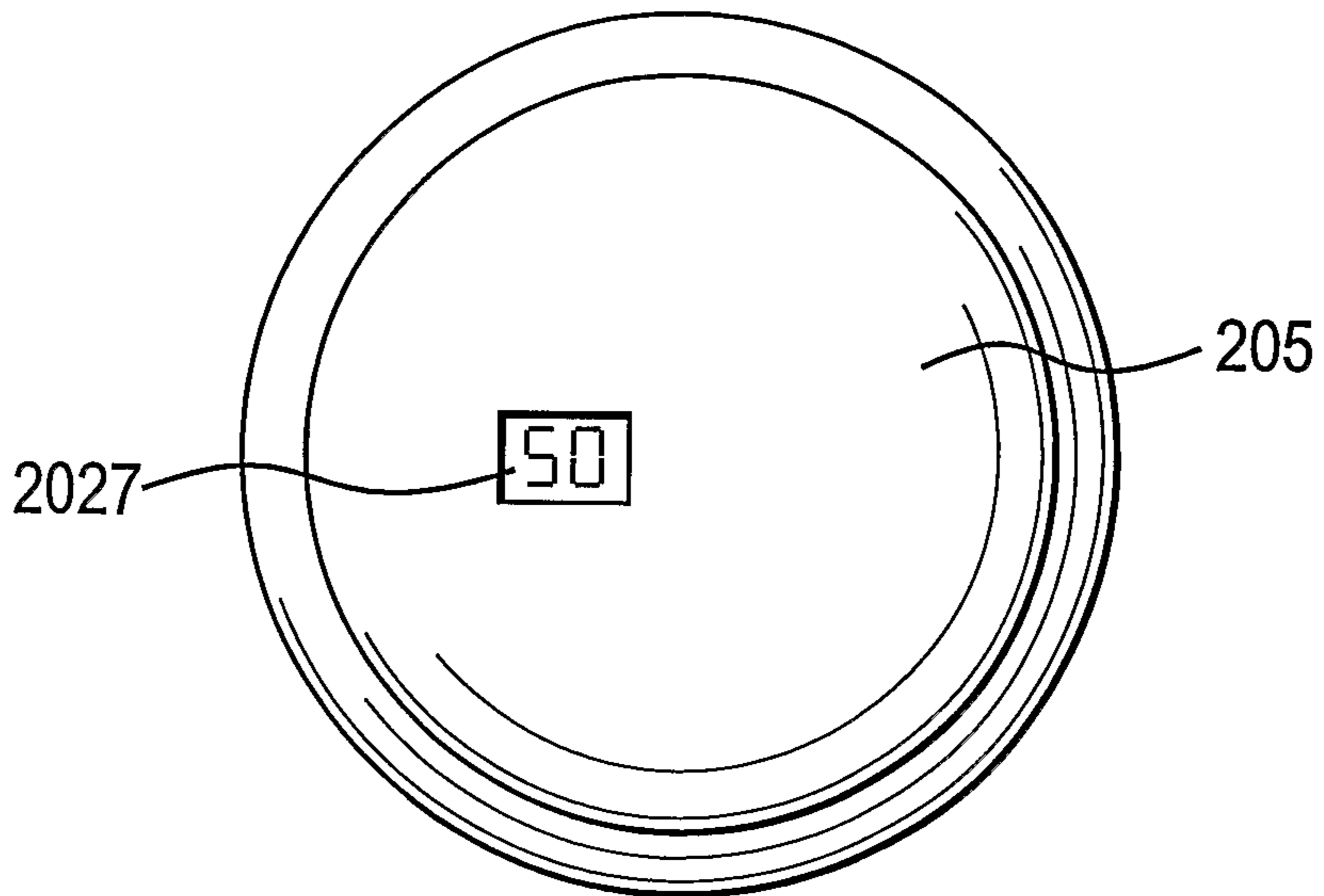

FIG. 7

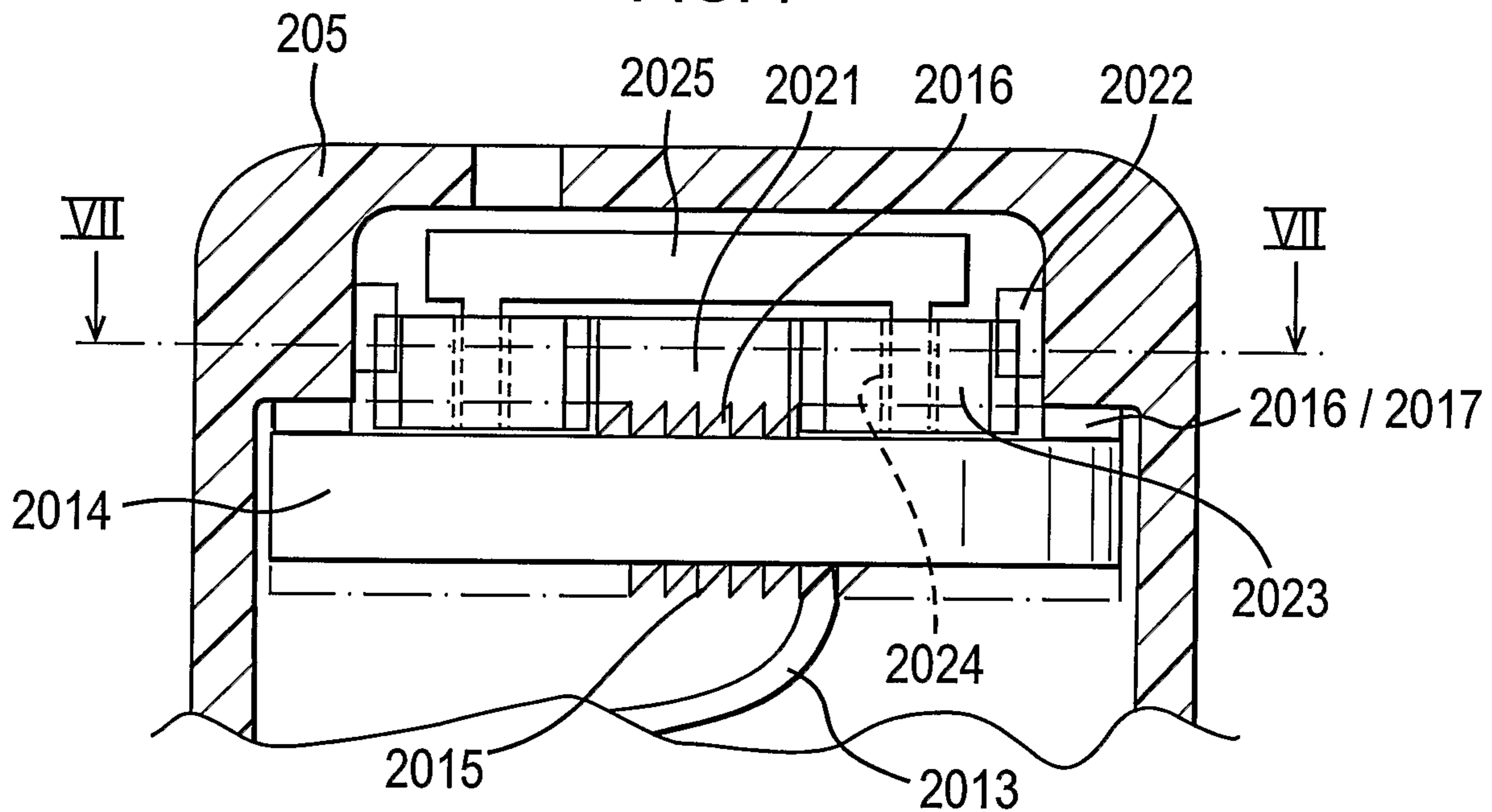
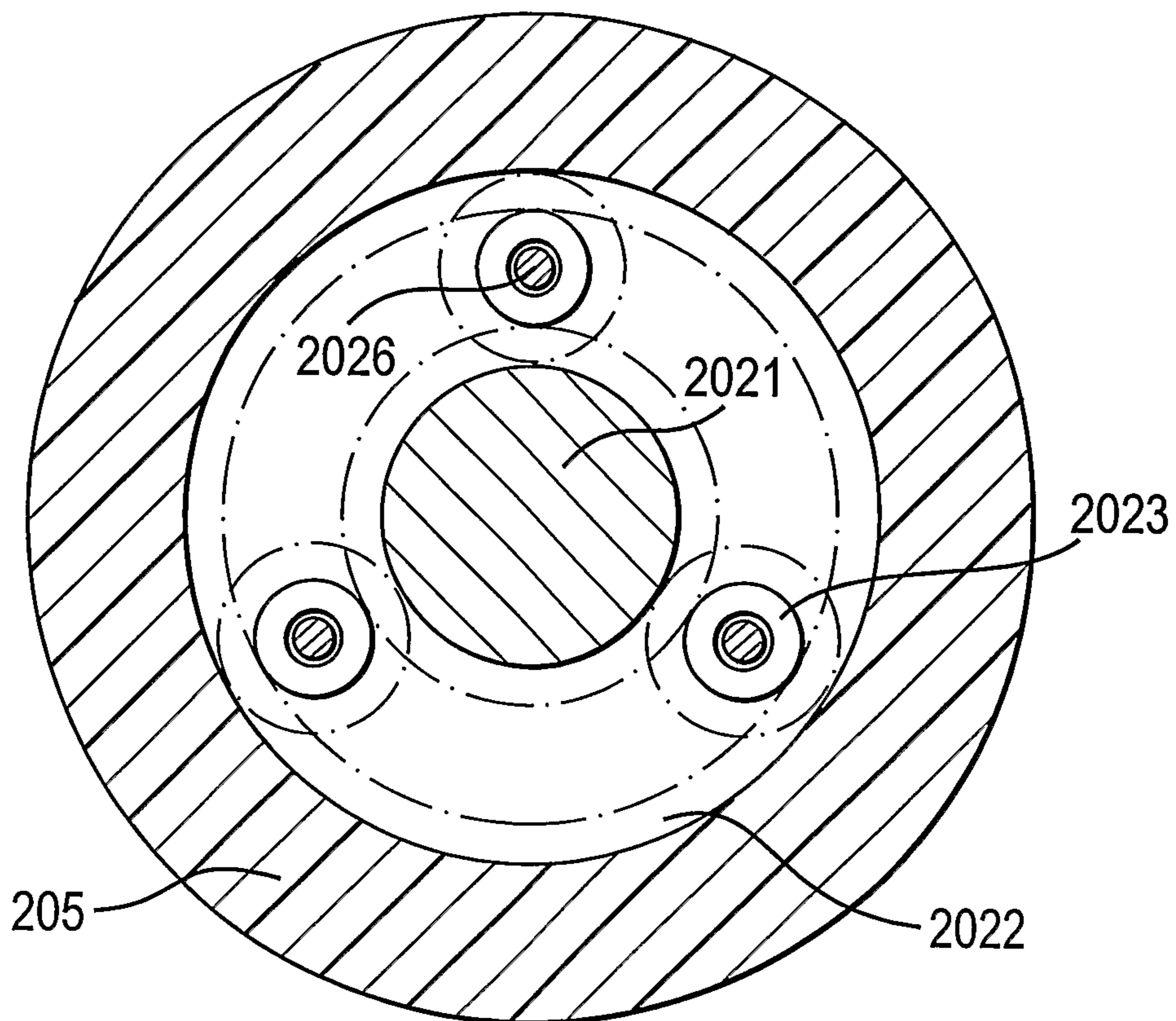

FIG. 8



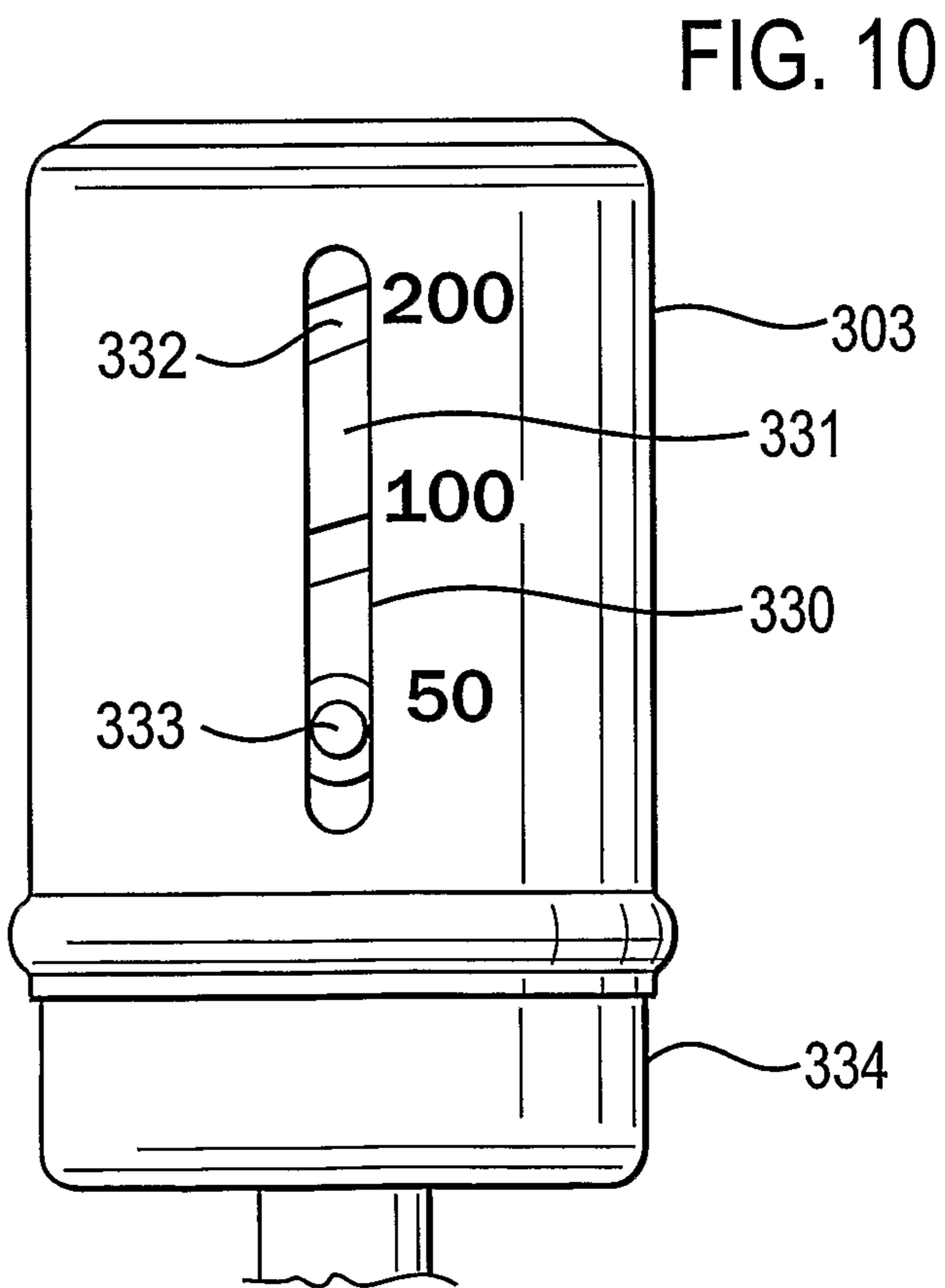
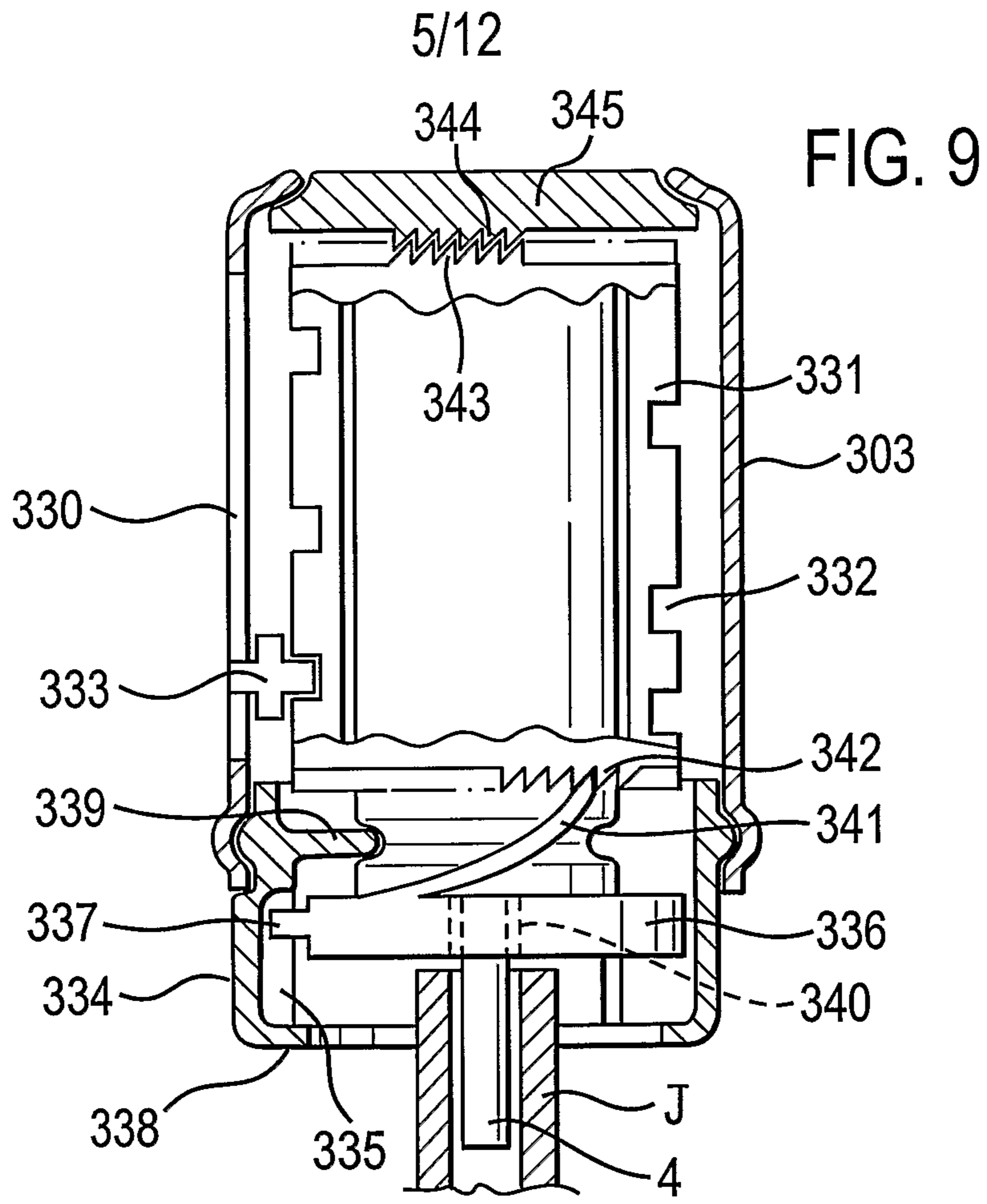

FIG. 11

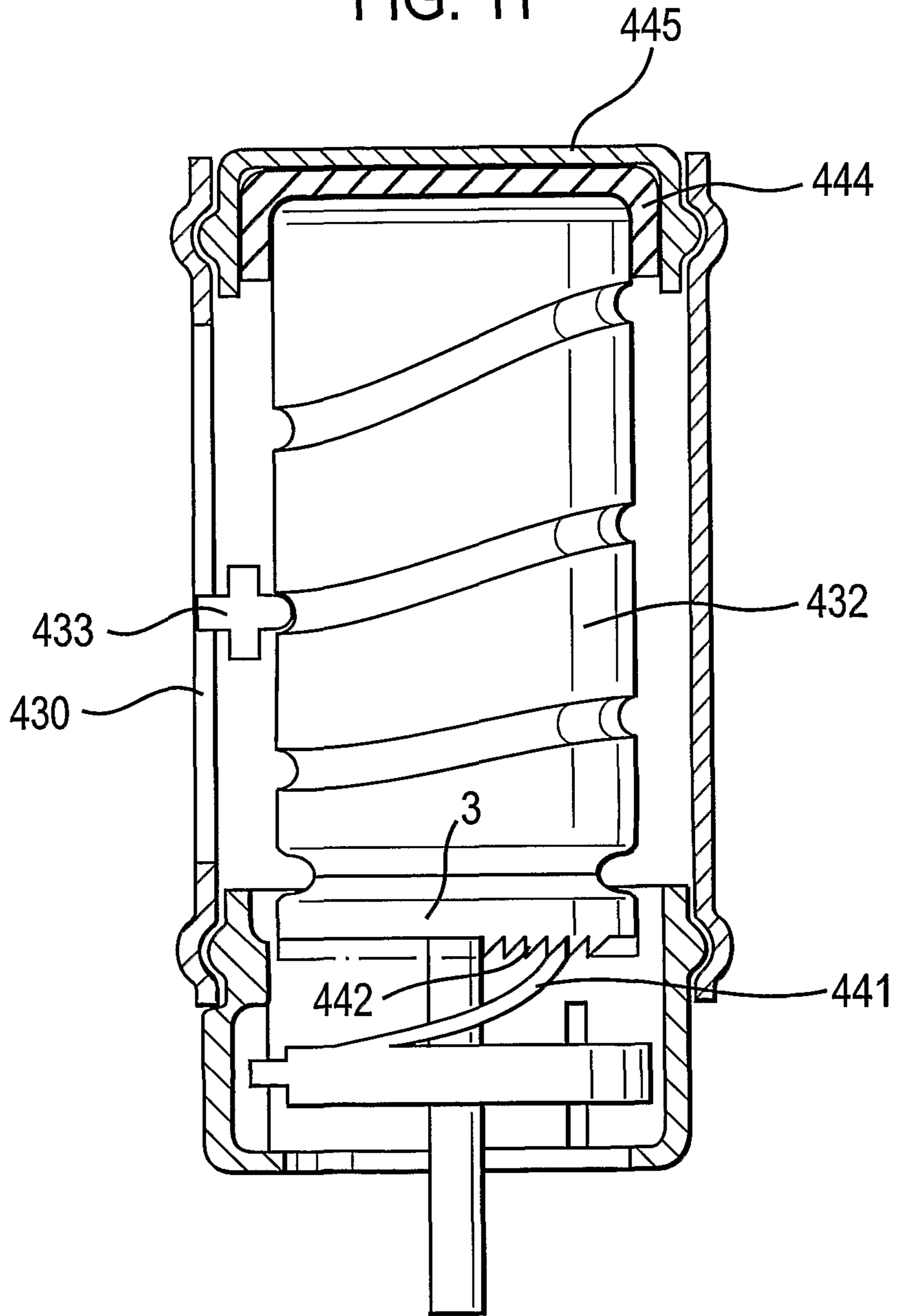
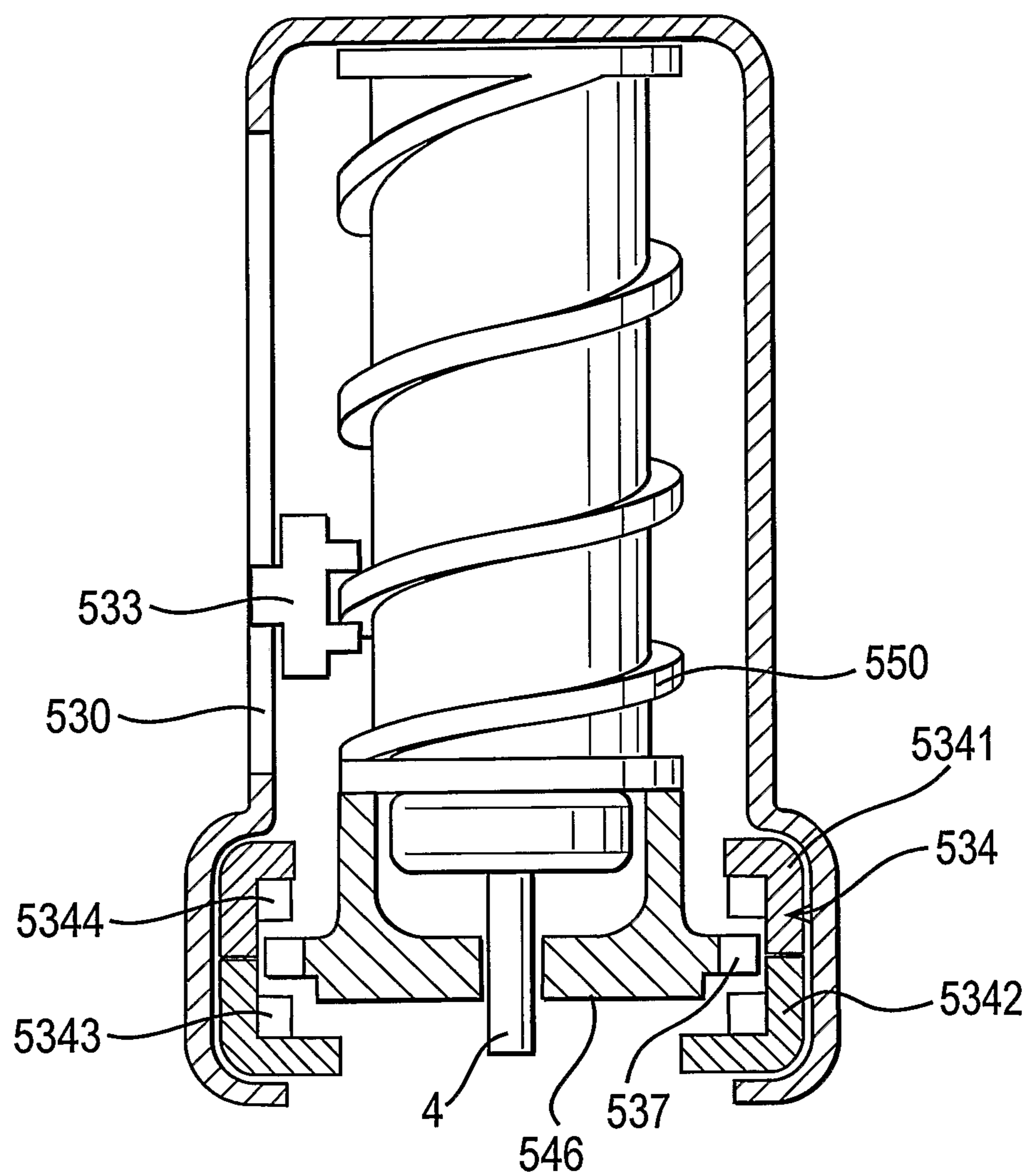

FIG. 12



8/12
FIG. 13

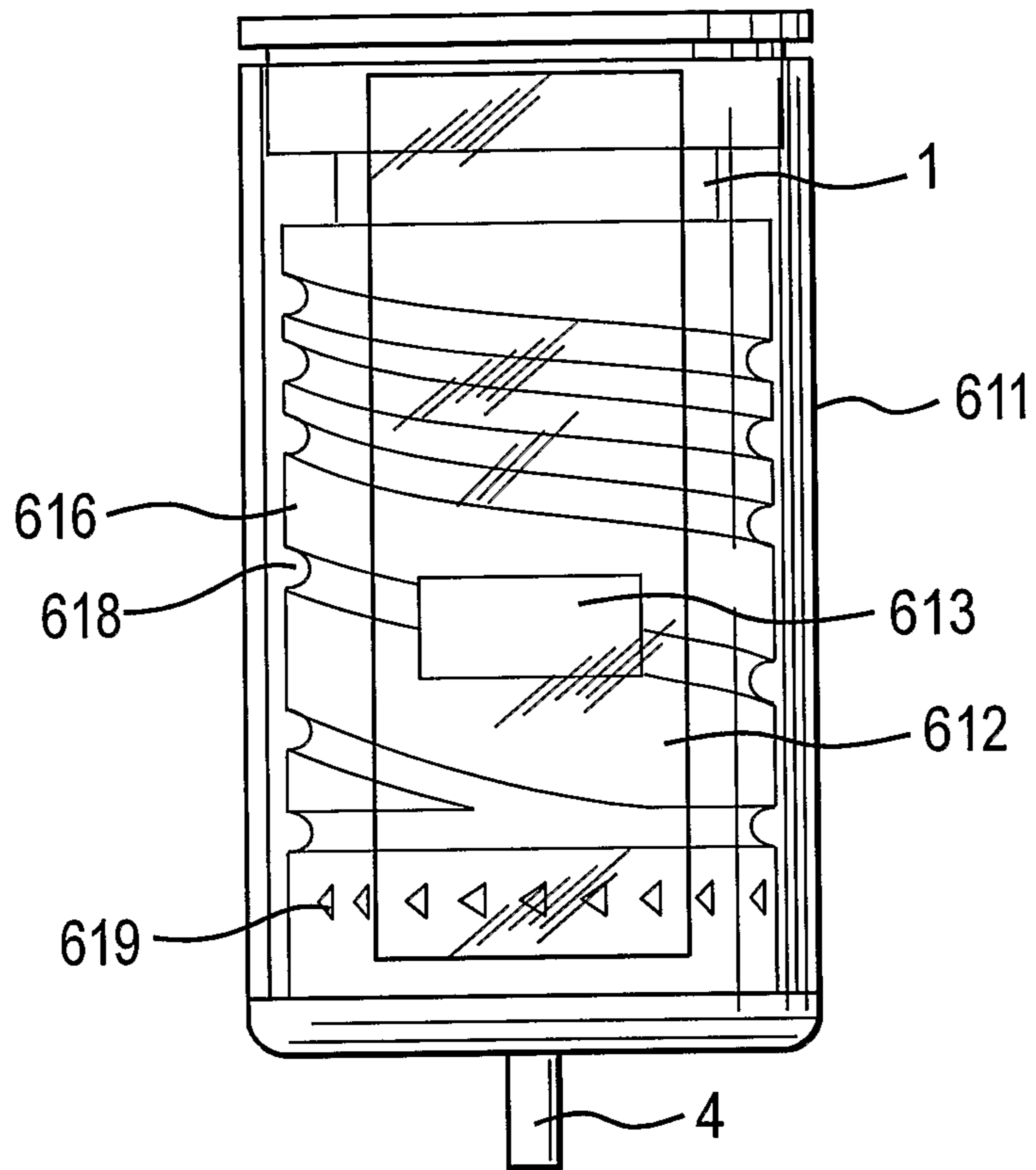

FIG. 14

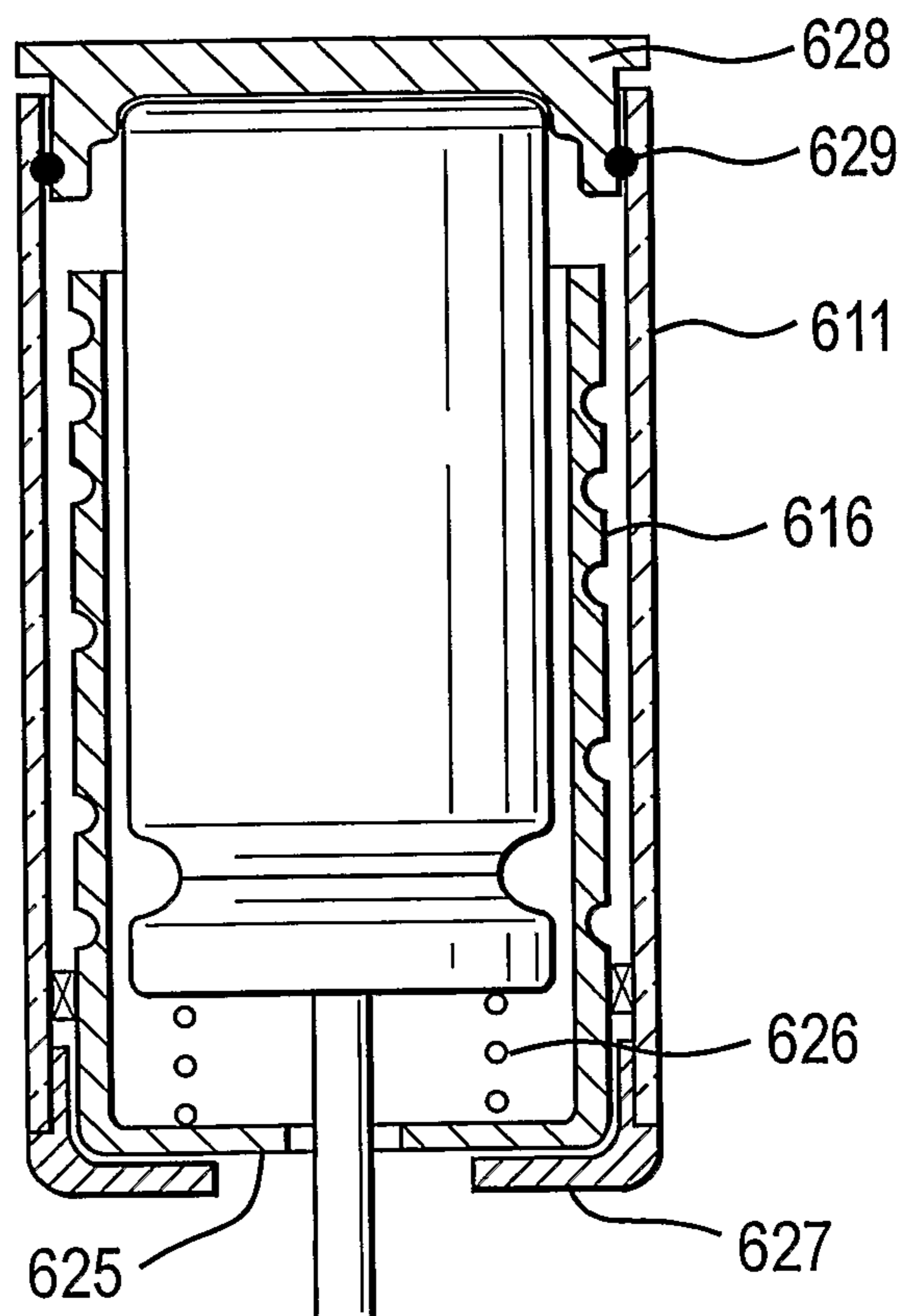

FIG. 15

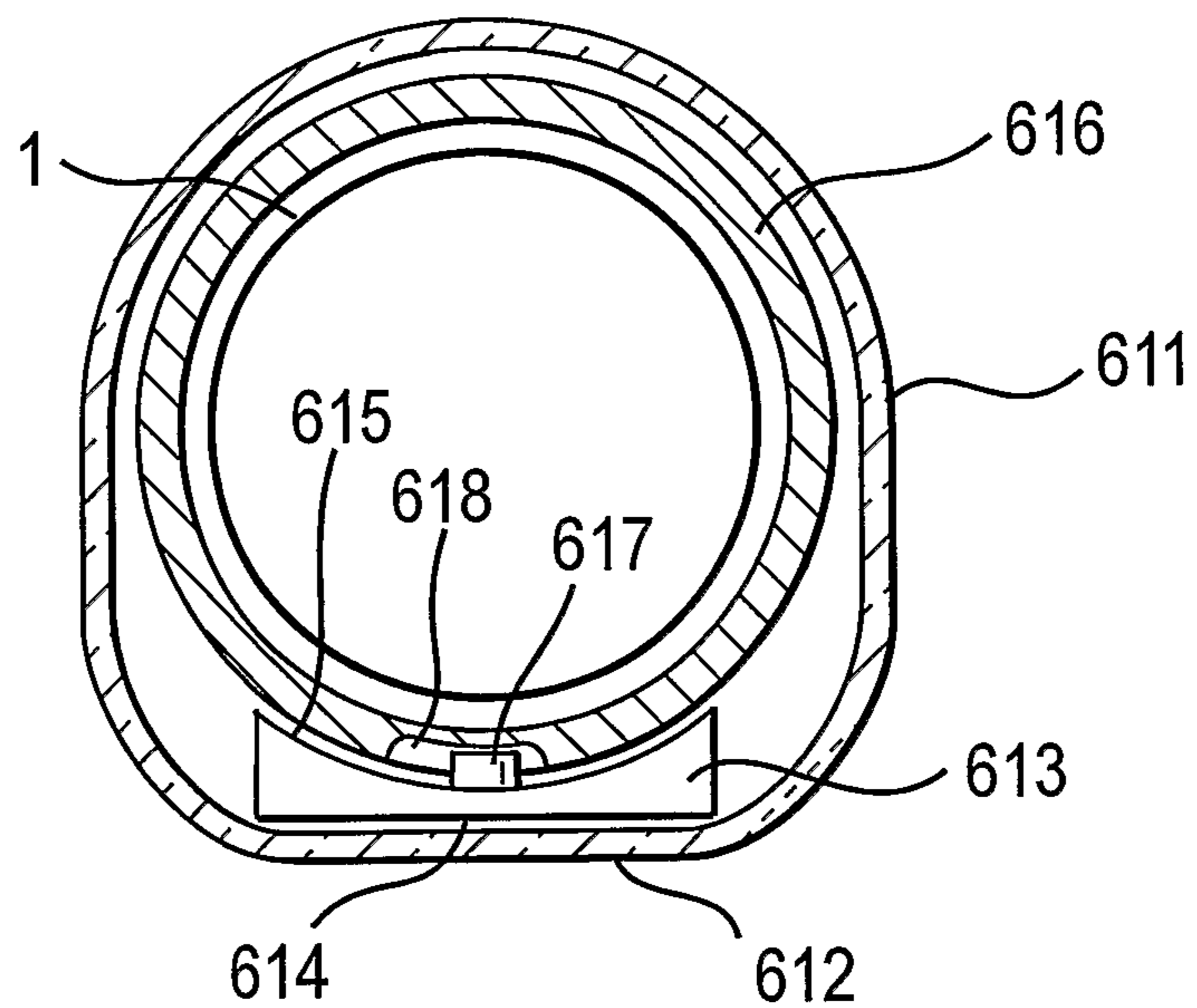

FIG. 16

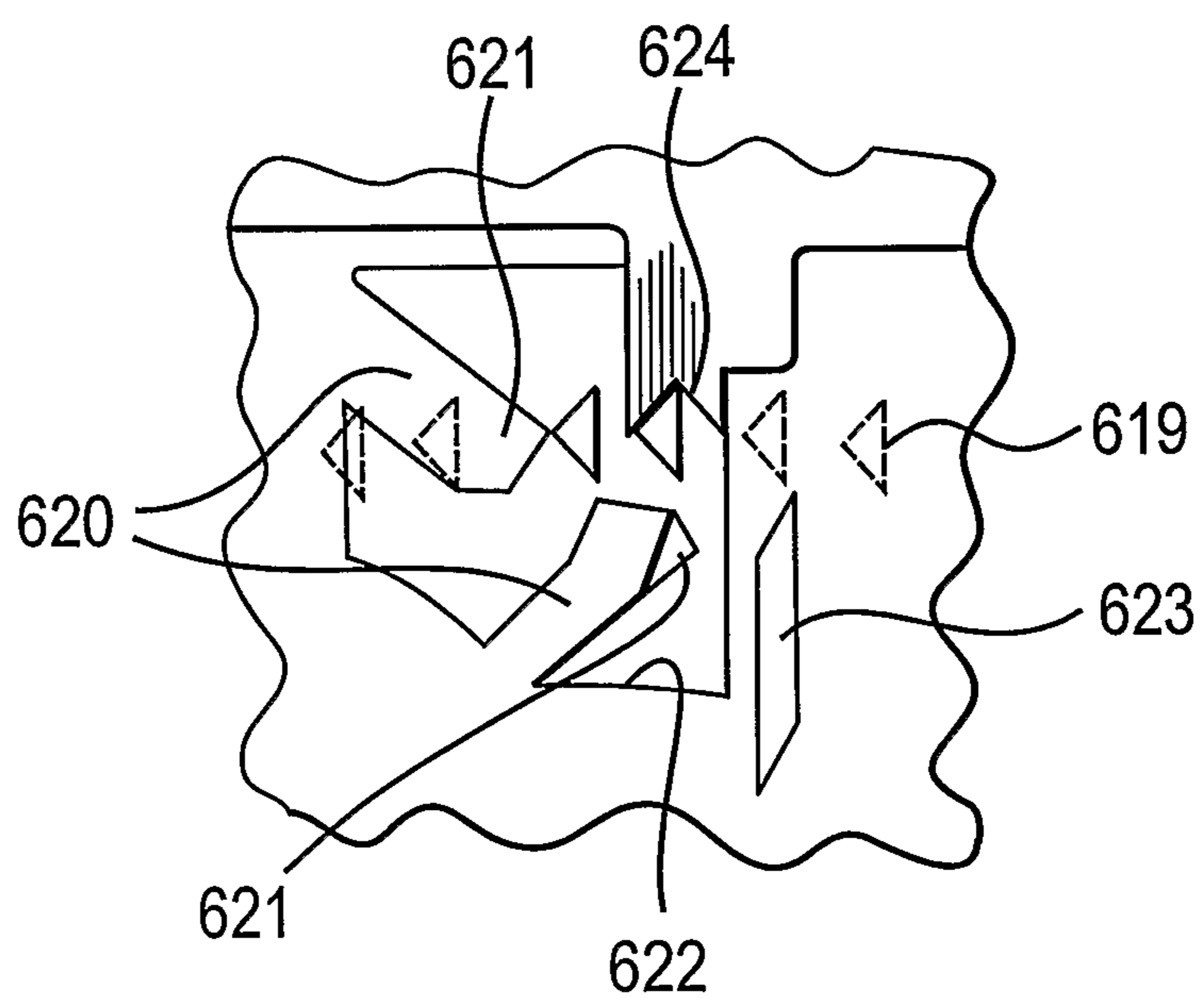

FIG. 17

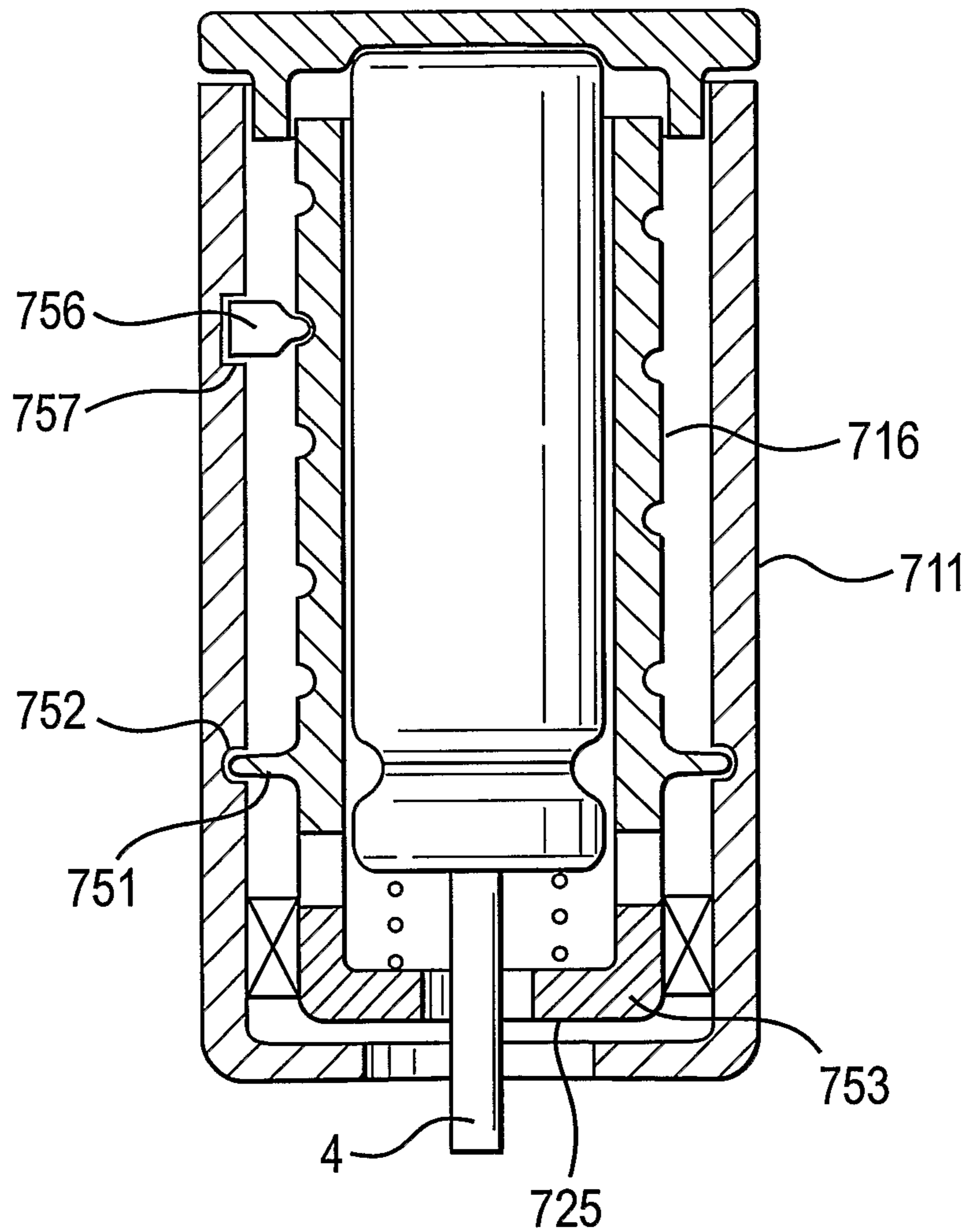

FIG. 18

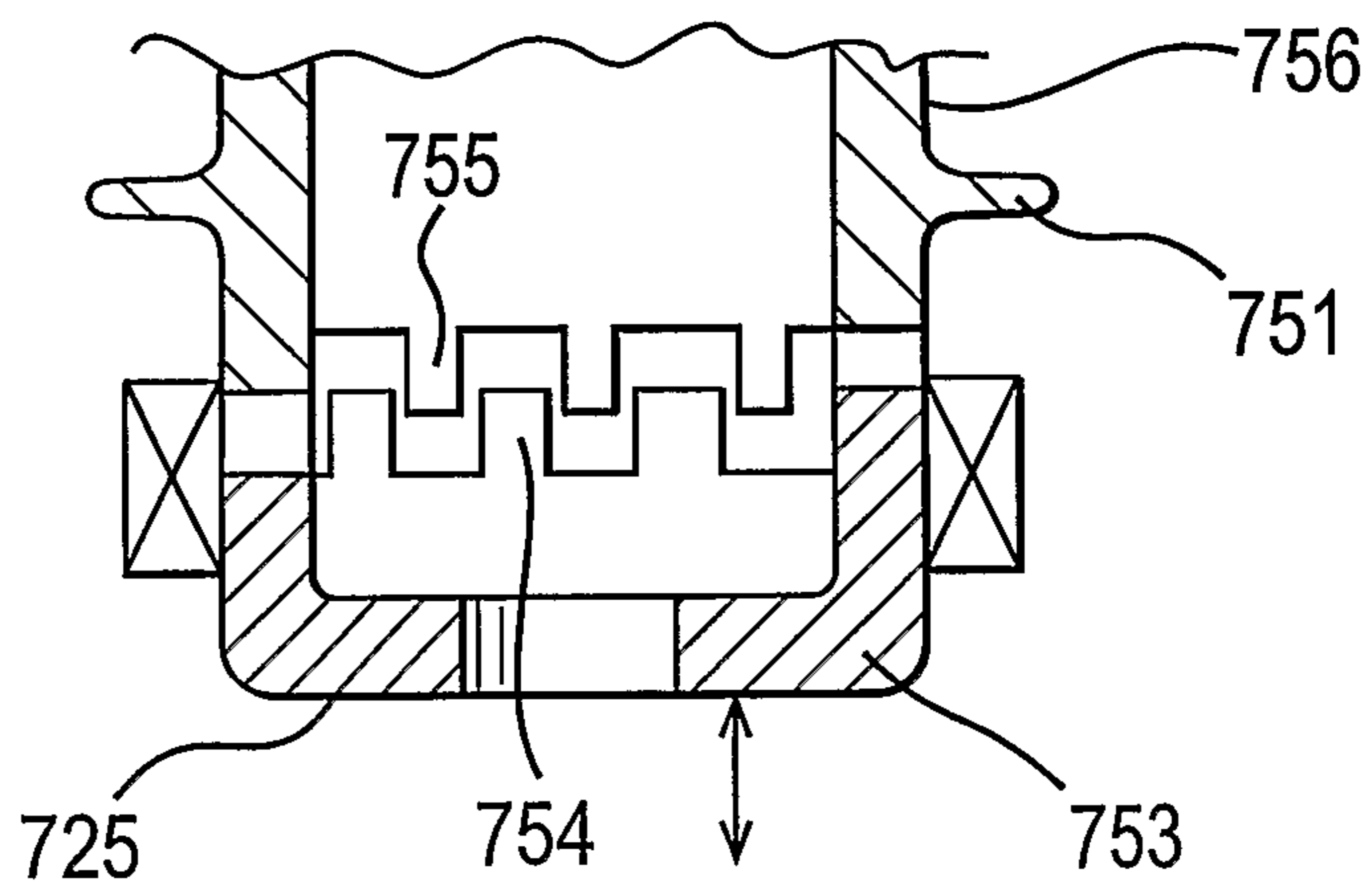
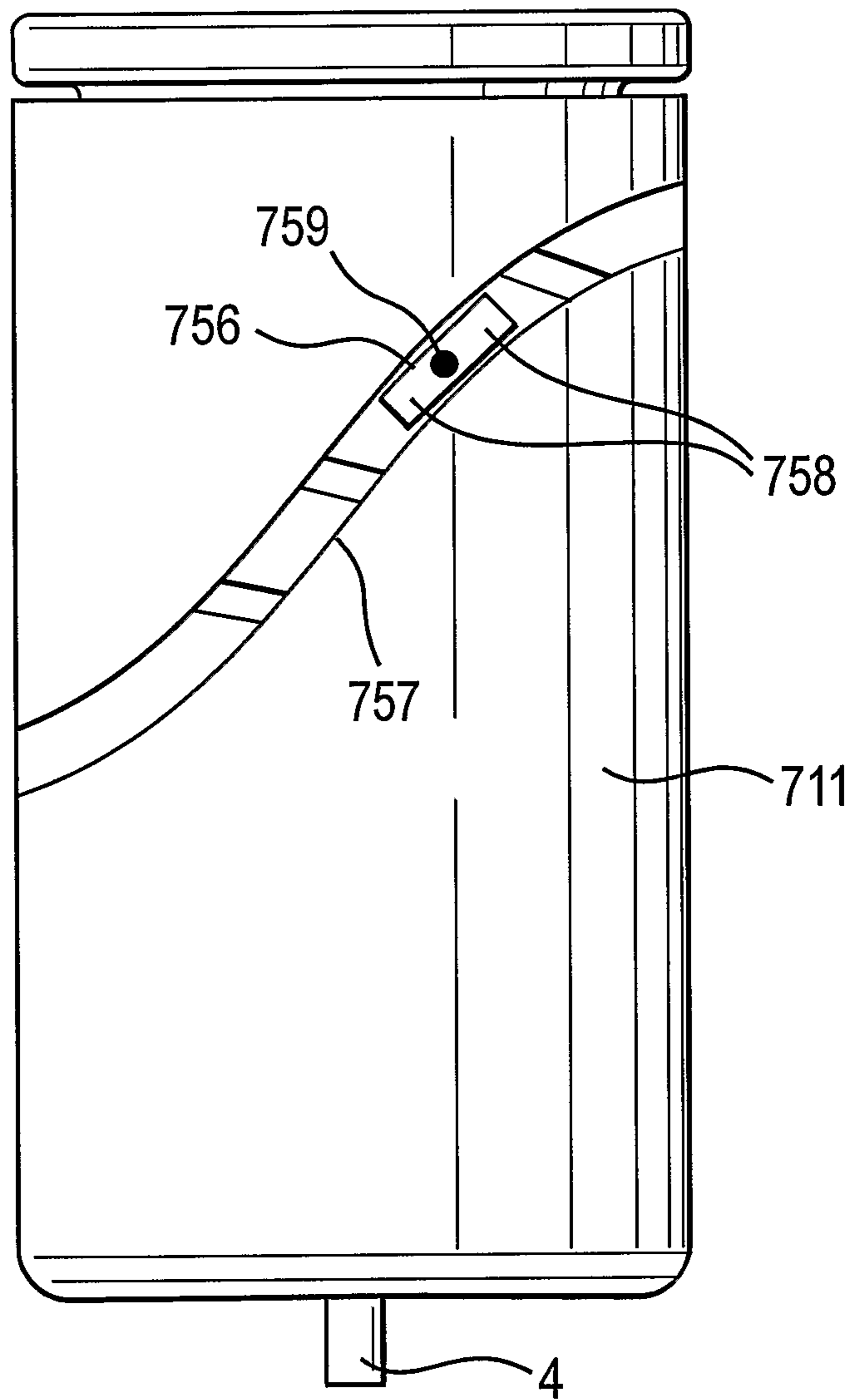

FIG. 19



12/12

FIG. 20

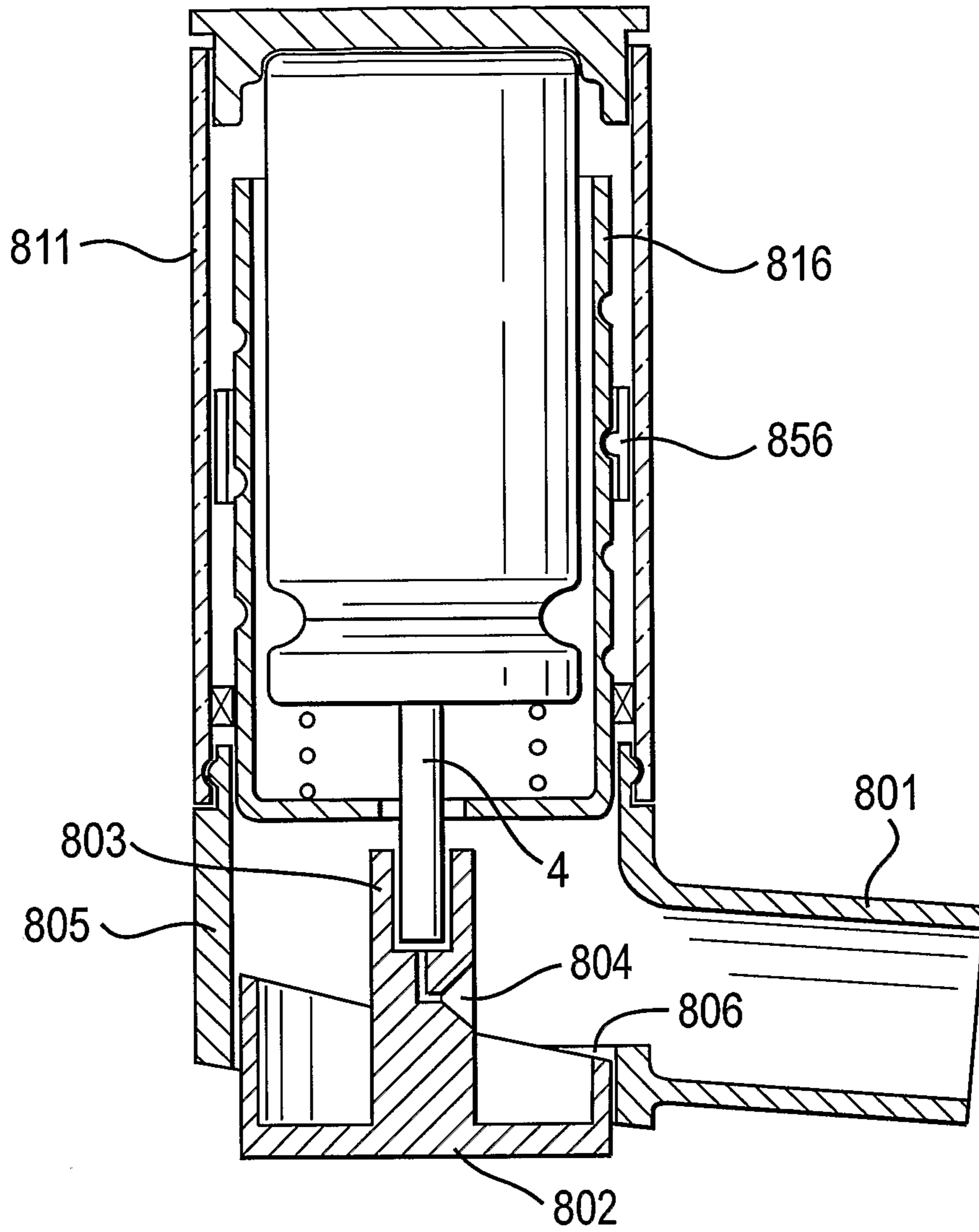

FIG. 21

