



- (51) **International Patent Classification:**
A61M 25/01 (2006.01) A61M 25/14 (2006.01)
A61M 25/09 (2006.01)
- (21) **International Application Number:**
PCT/US2015/040463
- (22) **International Filing Date:**
14 July 2015 (14.07.2015)
- (25) **Filing Language:** English
- (26) **Publication Language:** English
- (30) **Priority Data:**
62/024,323 14 July 2014 (14.07.2014) US
62/024,423 14 July 2014 (14.07.2014) US
- (71) **Applicant:** C. R. BARD, INC. [US/US]; 730 Central Avenue, Murray Hill, NJ 07974 (US).
- (72) **Inventors:** LOESENER, German; 9146 Jefferson Place, Sandy, UT 84070 (US). PRECHTEL, Ericka, J.; 2025 East 3110 South, Salt Lake City, UT 84109 (US).
- (74) **Agent:** WIGHT, Todd, W.; Rutan & Tucker LLP, 611 Anton Boulevard, Suite 1400, Costa Mesa, CA 92626 (US).
- (81) **Designated States** (unless otherwise indicated, for every kind of national protection available): AE, AG, AL, AM,

AO, AT, AU, AZ, BA, BB, BG, BH, BN, BR, BW, BY, BZ, CA, CH, CL, CN, CO, CR, CU, CZ, DE, DK, DM, DO, DZ, EC, EE, EG, ES, FI, GB, GD, GE, GH, GM, GT, HN, HR, HU, ID, IL, IN, IR, IS, JP, KE, KG, KN, KP, KR, KZ, LA, LC, LK, LR, LS, LU, LY, MA, MD, ME, MG, MK, MN, MW, MX, MY, MZ, NA, NG, NI, NO, NZ, OM, PA, PE, PG, PH, PL, PT, QA, RO, RS, RU, RW, SA, SC, SD, SE, SG, SK, SL, SM, ST, SV, SY, TH, TJ, TM, TN, TR, TT, TZ, UA, UG, US, UZ, VC, VN, ZA, ZM, ZW.

- (84) **Designated States** (unless otherwise indicated, for every kind of regional protection available): ARIPO (BW, GH, GM, KE, LR, LS, MW, MZ, NA, RW, SD, SL, ST, SZ, TZ, UG, ZM, ZW), Eurasian (AM, AZ, BY, KG, KZ, RU, TJ, TM), European (AL, AT, BE, BG, CH, CY, CZ, DE, DK, EE, ES, FI, FR, GB, GR, HR, HU, IE, IS, IT, LT, LU, LV, MC, MK, MT, NL, NO, PL, PT, RO, RS, SE, SI, SK, SM, TR), OAPI (BF, BJ, CF, CG, CI, CM, GA, GN, GQ, GW, KM, ML, MR, NE, SN, TD, TG).

Declarations under Rule 4.17:

— of inventorship (Rule 4.17(iv))

Published:

- with international search report (Art. 21(3))
- before the expiration of the time limit for amending the claims and to be republished in the event of receipt of amendments (Rule 48.2(h))

(54) **Title:** APPARATUSES, SYSTEMS, AND METHODS FOR INSERTING SPLIT TIP CATHETERS HAVING ENHANCED STIFFENING AND GUIDING FEATURES

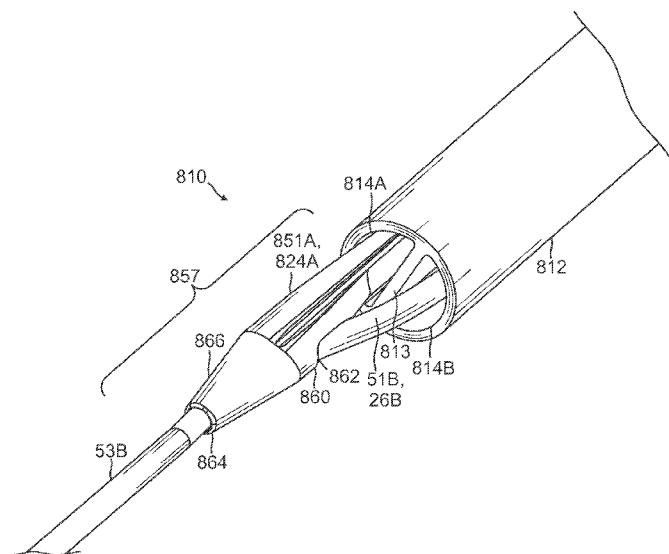

FIG. 24

(57) **Abstract:** Catheter apparatuses, systems, and methods for introducing a catheter into a patient's body. In one embodiment, a catheter apparatus includes a catheter body having a first lumen capable of fluid communication via a first distal opening and a second lumen capable of fluid communication via a second distal opening, a first intra-catheter stiffener element for disposition through the first lumen such that a distal end thereof is distal in relation to the first distal opening, and a second intra-catheter stiffener element configured for disposition through the second lumen such that a distal end thereof is distal in relation to the second distal opening, one of the first intra-catheter stiffener element distal end and the second intra-catheter stiffener element distal end capable of receiving and accommodating the other of the first intra-catheter stiffener element distal end and the second intra-catheter stiffener element distal end.

WO 2016/011091 A1

**APPARATUSES, SYSTEMS, AND METHODS FOR INSERTING SPLIT TIP
CATHETERS HAVING ENHANCED STIFFENING AND GUIDING FEATURES**

PRIORITY

[0001] This application claims the benefit of priority to U.S. Provisional Application No. 62/024,323, filed July 14, 2014, and to U.S. Provisional Application No. 62/024,423, filed July 14, 2014, each of which is incorporated by reference in its entirety into this application.

BACKGROUND

[0002] Related art multi-lumen catheters are desirable for various treatment applications such as hemodialysis where fluid extraction and infusion occur simultaneously. These related art multi-lumen catheters provide a single catheter application having multiple lumen channels, each channel supporting independent flow, thus, precluding the need for inserting multiple catheters or multiple-catheter assemblies. Further, because a patient might require frequent dialysis, often only days apart, securing placement of the catheter for extended periods of time may be required. Extended placement, however, requires extreme catheter flexibility to avoid damage to the blood vessel and to permit the catheter to move in the blood flow in order to minimize the possibility of the catheter remaining in contact with the wall of the vessel for prolonged periods, otherwise causing undue pressure thereon. Related art stylets also have a tendency to snag interior surfaces of a blood vessel, thereby unduly damaging the blood vessel.

[0003] An example of a related art multi-lumen catheter includes an elongated tubular body extending to a distal end. The tubular body has a first and a second lumen with a septum disposed therebetween. The tubular body includes a first wall that defines the first lumen and a second wall that defines the second lumen. A portion of the septum extends distally beyond the first lumen and the second lumen. The first wall includes a first wall extension that extends distally beyond the first lumen and is spaced apart from the portion of the septum. The first wall extension defines a concave surface facing the portion of the septum. Alternatively, the catheter includes a tip with spiraled configuration. The catheter may also include a third lumen.

[0004] Another example of a related art multi-lumen catheter includes a tubular body having a proximal end and a distal end. The body includes a first lumen and a second lumen with a septum disposed therebetween. The proximal end includes a valve and a hub that are integral with the body. The hub includes a first conduit and a second conduit. The valve

includes a first port and a second port that are rotatable, about a longitudinal axis of the body, to establish fluid communication between the lumens and the conduits. The distal end of the tubular body is configured for insertion. The conduits are connectable to a medical apparatus.

[0005] Yet another example of a related art multi-lumen catheter includes an elongated tubular body extending to a distal end. The tubular body has a first and a second lumen with a septum disposed therebetween and has a first wall that defines the first lumen and a second wall that defines the second lumen. A portion of the septum extends distally beyond the first lumen and the second lumen. The first wall includes a first wall extension that extends distally beyond the first lumen and is spaced apart from the portion of the septum. The first wall extension defines a concave surface facing the portion of the septum. Alternatively, the septum has a septum extension that extends distally beyond the first lumen and the second lumen; and the septum extension defines a first planar surface and an opposing second planar surface.

[0006] Unfortunately, these related art catheters introduce insertion difficulties, including a relative inflexibility thereof. For example, simply advancing the catheter over a guide-wire is very difficult in the related art, since the catheter has a tendency to buckle during disposition through the blood vessel wall as well as during further disposition into the blood vessel to the desired location. Flexible catheters present additional difficulties associated with subcutaneous tunneling and placement. Related art insertion methods and assemblies attempt to overcome, or at least mitigate, these insertion difficulties by temporarily stiffening the catheter during the insertion process.

[0007] For example, one related art method involves temporarily inserting a rigid tubular applicator into one of the lumens. This permits the stiffened catheter/applicator assembly to be passed over a guide-wire into a desired position, at which point the applicator can be removed. For example, U.S. Pat. No. 5,405,341 attempts to solve the problem with a single rigid applicator that is designed for insertion into one lumen but also passes through a portion of the second lumen (at the distal end of the instrument) to effectively stiffen the two lumens of the catheter together during insertion. This related art approach is cumbersome, at best, and presents additional difficulties in maneuvering the instrument. Further, this temporary rigid applicator approach is poorly suited for placement of a catheter having a split at its distal end into two or more separate lumens, e.g., to further isolate a fluid extraction lumen from a return infusion lumen, because only one tip can be secured. Hence, a need exists for

better and more effective apparatuses, systems, and methods for inserting flexible catheters into blood vessels.

SUMMARY

[0008] The present disclosure addresses at least the foregoing needs and provides apparatuses, systems, such as kits, and methods for inserting flexible, multi-lumen catheters into blood vessels, and in particular, for inserting flexible, split-tip catheters into blood vessels. These objects can be accomplished, for example, by temporarily stiffening each catheter lumen and tip independently through use of intra-catheter stiffener elements disposed within the catheter lumens. The apparatuses, systems (such as kits), and methods described herein facilitate advancing the assembly of catheter and stiffeners through a subcutaneous tunnel, and over a plurality of guide-wires until a distal portion of the catheter is disposed at a desired position within the blood vessel.

[0009] The intra-catheter stiffener elements, such as the presently disclosed enhanced stylets, are sufficiently stiff to allow advancing the catheter over guide-wires, but also sufficiently flexible to allow bending and looping of the catheter for proper placement within the vessel. Further, the intra-catheter stiffener elements prevent catheter kinking during the insertion process. In one embodiment, the intra-catheter stiffener elements have tapered distal ends which can facilitate entry of the catheter/stiffeners assembly into a blood vessel and/or assist in dilating the blood vessel.

[0010] One aspect of the present disclosure provides apparatuses, systems, such as kits, and methods for inserting an antegrade tunneled, split-tip, hemodialysis catheter into a blood vessel. A distal portion of each of a plurality of guide-wires is disposed in a blood vessel at a first location, generally in proximity to the vessel in which a portion of the catheter, e.g., a catheter body, is to be placed. A subcutaneous tunnel is formed between the first location and a second location where a proximal end of the catheter can extend from the patient. An intra-catheter stiffener element is inserted into the proximal end of each catheter lumen until the intra-catheter stiffener element extends beyond the distal end of that catheter lumen. The intra-catheter stiffener element can be releasably coupled, following insertion, to the proximal end of its respective catheter lumen via, for example, a mating luer assembly. Each guide-wire can be inserted into a distal end of a lumen in a respective intra-catheter stiffener element until that guide-wire extends from the proximal end of that intra-catheter stiffener element. The catheter

can then be advanced over the guide-wires and into the blood vessel. Alternatively, the catheter can be advanced over the guide-wires until a distal end of the catheter is adjacent to the vessel, at which point the catheter and guide-wires can be advanced together into the vessel until the distal end of the catheter is at a desired location therein. Twisting the catheter while simultaneously advancing the catheter along the guide-wires can facilitate placement of the catheter into the vessel.

[0011] In another aspect, the apparatuses, systems, such as kits, and methods of the present disclosure provide for inserting a retrograde tunneled hemodialysis catheter into a blood vessel. A distal portion of each of a plurality of guide-wires is inserted into a blood vessel at a first location generally as described above. An intra-catheter stiffener element is placed in each catheter lumen until it extends from a distal end of the catheter, and can be releasably connected to the proximal end of its respective catheter lumen, as noted above. A proximal end of each guide-wire is threaded through the distal end of a lumen of each intra-catheter stiffener element until the guide-wire extends beyond the proximal end of that stiffener element. The catheter is advanced over the guide-wires, optionally using a twisting motion, until a distal portion of the catheter is disposed at a desired location within the vessel, or alternatively, the catheter can be advanced until its distal end is adjacent to the vessel, at which point the catheter and guide-wires can be advanced together until the distal end of the catheter is disposed at a desired location within the vessel. The guide-wires are removed from the catheter lumens. A subcutaneous tunnel is then formed between the first location and a second location, and the proximal end of the catheter is passed through the first location until it extends from the second location. (If the stiffener elements have not previously been removed, they can be removed from the catheter body following passage of the catheter through the tunnel.) An access port is connected to the proximal end of each of the catheter lumens allowing fluid connection with a treatment device, such as a hemodialysis infuser.

[0012] In a related aspect, the apparatuses, systems, such as kits, and methods of the present disclosure can provide for dilating the desired vessel subsequent to inserting the distal portion of a first guide-wire. For example, a size 6-French sheath/dilator can be threaded over the first guide-wire. Further guide-wires can then be inserted into the expanded vessel, or through a lumen in the sheath and into the vessel. After placement of the guide-wires into the vessel, the dilator or sheath can be removed.

[0013] In a further related aspect, the methods provide for tunneling between the first and second location by using a pointed stylet. A distal end of a pointed stylet can be inserted through the skin at the second location and pushed toward the first location until the distal end extends therefrom. The distal end of the catheter is removably attached to a proximal end of the stylet. The stylet is then pulled from the first location until the distal end of the catheter extends therefrom, to facilitate an antegrade tunneled catheter.

[0014] Alternatively, a pointed distal end of a stylet can be inserted through the skin at the first location and pushed until it extends from the second location. The proximal end of the catheter can be removably attached to the proximal end of the stylet. The stylet is then pulled back toward the second location until the proximal end of the catheter extends therefrom. The catheter is then released from the stylet, thus positioning a retrograde tunneled catheter. To facilitate movement of the catheter within the tunnel, the proximal end of the catheter having mating lures or other coupling features can be removed or severed prior to attachment to the stylet. After tunneling the catheter, fluid couplings or other attachments can be disposed to the proximal end of the lumens.

[0015] Preferably, the vessel is expanded to accommodate placement of the distal portion of the catheter in the vessel. Vessel dilators of increasing size can be sequentially inserted into the vessel for this purpose. For example, a size 12-French dilator followed by a size 14-French, which is then followed by a size 16-French dilator, can be inserted into the vessel before advancing the catheter along the guide-wires. In other embodiments, fewer (or more) dilators of different sizes can be used. Differing size and number of vessel dilators can be used corresponding to the catheter chosen for the desired application. Use of intra-catheter stiffener elements can preclude use of vessel dilators sized larger than the catheter since the stiffener elements and the catheter itself can provide vessel dilation.

[0016] Another aspect of the present disclosure provides for apparatus, in the form of a kit, to insert a multi-lumen catheter into a blood vessel. The kit includes guide-wires each adapted to have a distal portion inserted into a blood vessel. A plurality of intra-catheter stiffener elements preferably having tapered distal ends are also provided, each having a lumen extending along its length sized to accommodate a guide-wire, and each having an outside diameter sized to be slidably disposed within a lumen of the catheter. The intra-catheter stiffener elements can be provided in one or more predetermined lengths corresponding to a length of a catheter and its lumens selected for a particular use, or can be of the same length.

Further, the intra-catheter stiffeners can be provided with mating devices, such as lures, disposed at a proximal end correspond with mating connectors disposed at a proximal end of the catheter lumens.

[0017] One or more vessel dilators can also be provided in the kit, each corresponding in size to a particular application. For example, a size 6-French sheath/dilator can be provided to dilate the vessel to accommodate a plurality of guide-wires. A size 12-French, 14-French, as well as a size 16-French, dilator can be provided to dilate the vessel to accommodate the distal tip of the catheter.

[0018] In addition, rather than two separate stylets, the apparatuses, systems, such as kits, and methods further encompass embodiments including: a plurality of stylets, such as two stylets, joined at a proximal end; a lumen disposed within each stylet of the plurality of stylets, wherein the lumen is sized and shaped to receive a flexible rod capable of expanding the stylet tip to a conical shape, and wherein the conical shape is removed contemporaneously with the flexible rod; and a plurality of stylets, each stylet of the plurality of stylets having a hemispherical tip rather than a taper.

[0019] Alternatively, a catheter apparatus includes: a catheter body comprising a first lumen capable of fluid communication via a first distal opening and a second lumen capable of fluid communication via a second distal opening; a first intra-catheter stiffener element configured for disposition through the first lumen such that a distal end thereof is distal in relation to the first distal opening, the first intra-catheter stiffener element comprising one of a guide-wire and a stylet; and a second intra-catheter stiffener element configured for disposition through the second lumen such that a distal end thereof is distal in relation to the second distal opening, the second intra-catheter stiffener element comprising a guide-wire, one of the first intra-catheter stiffener element distal end and the second intra-catheter stiffener element distal end capable of receiving and accommodating the other of the first intra-catheter stiffener element distal end and the second intra-catheter stiffener element distal end, in accordance with an embodiment of the present disclosure.

[0020] In one embodiment, a first intra-catheter stiffener element and a second intra-catheter stiffener element include at least one of an eye portion and a looped portion disposed at the distal end thereof capable of receiving and facilitating disposition therethrough of the distal end of the other of the first intra-catheter stiffener element and the second intra-catheter

stiffener element. The catheter body in which the first and second intra-catheter stiffener elements are disposed includes a septum for separating the first lumen and the second lumen from one another, the septum having a distal end extending beyond at least one of the first distal opening and the second distal opening for at least minimizing backflow into at least one of the first lumen and the second lumen. One of the first intra-catheter stiffener element and the second intra-catheter stiffener element includes a cover portion at the distal end thereof, the cover portion capable of deployment and retraction in relation to one of the first lumen and the second lumen, and the cover portion cooperatively engageable with the septum distal end for at least minimizing backflow into the one of the first lumen and the second lumen. The cover portion is deployable and retractable via at least one technique of a rotation and a translation in relation to a longitudinal axis thereof. One or both of the first and second intra-catheter stiffener elements may have a monolithic configuration or a tapered configuration. The first intra-catheter stiffener element may have a first length, and the second intra-catheter stiffener element may have a second length different from the first length. The first intra-catheter stiffener element may include a first coupler at a proximal end thereof, and the second intra-catheter stiffener element may include a second coupler at a proximal end thereof. The distal end of the first intra-catheter stiffener element may be distal in relation to the distal end of the second intra-catheter stiffener element when the first coupler and second coupler are coupled to the catheter body. The first coupler of the first intra-catheter stiffener element may be configured to mate with a first mating coupler at a first proximal opening of the catheter body, and the second coupler of the second intra-catheter stiffener element may be configured to mate with a second mating coupler at a second proximal opening of the catheter body. The first intra-catheter stiffener element may include an exterior cross-sectional shape complementing an interior cross-sectional shape of the first lumen, and the second intra-catheter stiffener element may include an exterior cross-sectional shape complementing an interior cross-sectional shape of the second lumen. The exterior cross-sectional shape of the first intra-catheter stiffener element may include a round shape, an oval shape, an elliptical shape, or an ovoidal shape, and the exterior cross-sectional shape of the second intra-catheter stiffener element may include a round shape, an oval shape, an elliptical shape, or an ovoidal shape.

[0021] Further, a method of fabricating a catheter apparatus, includes providing/obtaining a catheter comprising a first lumen capable of fluid communication via a first distal opening and a second lumen capable of fluid communication via a second distal opening; providing/obtaining a first intra-catheter stiffener element configured for disposition

through the first lumen such that a distal end thereof is distal in relation to the first distal opening, the first intra-catheter stiffener element comprising one of a guide-wire and a stylet; and providing/obtaining a second intra-catheter stiffener element configured for disposition through the second lumen such that a distal end thereof is distal in relation to the second distal opening, the second intra-catheter stiffener element comprising a guide-wire, providing/obtaining the first intra-catheter stiffener element and providing/obtaining a second intra-catheter stiffener element, together, comprising providing/obtaining one of the first intra-catheter stiffener element distal end and the second intra-catheter stiffener element distal end as capable of receiving and accommodating the other of the first intra-catheter stiffener element distal end and the second intra-catheter stiffener element distal end, in accordance with an embodiment of the present disclosure.

[0022] Further, a method of fabricating a catheter apparatus, includes providing/obtaining a catheter comprising a first lumen capable of fluid communication via a first distal opening and a second lumen capable of fluid communication via a second distal opening; providing/obtaining a first intra-catheter stiffener element configured for disposition through the first lumen such that a distal end thereof is distal in relation to the first distal opening, the first intra-catheter stiffener element comprising one of a guide-wire and a stylet; and providing/obtaining a second intra-catheter stiffener element configured for disposition through the second lumen such that a distal end thereof is distal in relation to the second distal opening, the second intra-catheter stiffener element comprising a guide-wire, wherein the first intra-catheter stiffener element and the second intra-catheter stiffener element include a first intra-catheter stiffener element distal end and a second intra-catheter stiffener element distal end, respectively. The first lumen capable of receiving and accommodating the first intra-catheter stiffener element, and the second lumen capable of receiving and accommodating the second intra-catheter stiffener element distal end. The method may include inserting the first intra-catheter stiffener element into the first lumen and/or inserting the second intra-catheter stiffener element into the second lumen. The method may include steps to form any of the features described above or elsewhere in this disclosure, e.g., forming a catheter, stiffener element, and/or guide-wire with any of the shapes and/or features described herein. This may include forming these by extrusion, mold, carving, etching, injection mold, 3D printing, etc.

[0023] Furthermore, a method of treatment, treating a patient, and/or inserting a catheter into a blood vessel by way of a catheter apparatus, includes providing/obtaining the

catheter apparatus, the catheter apparatus comprising a catheter having a first lumen capable of fluid communication via a first distal opening and a second lumen capable of fluid communication via a second distal opening; providing/obtaining a first intra-catheter stiffener element configured for disposition through the first lumen such that a distal end thereof is distal in relation to the first distal opening, the first intra-catheter stiffener element providing comprising providing one of a guide-wire and a stylet; and providing/obtaining a second intra-catheter stiffener element configured for disposition through the second lumen such that a distal end thereof is distal in relation to the second distal opening, the second intra-catheter stiffener element providing/obtaining comprising providing/obtaining a guide-wire, providing/obtaining the first intra-catheter stiffener element and providing/obtaining a second intra-catheter stiffener element, together, comprising providing/obtaining one of the first intra-catheter stiffener element distal end and the second intra-catheter stiffener element distal end as capable of receiving and accommodating the other of the first intra-catheter stiffener element distal end and the second intra-catheter stiffener element distal end; creating a first entry; deforming the stylet tip by way of receiving and disposing the at least one elongated element in the at least one lumen; disposing a distal end of the catheter body through the first entry; creating a second entry; disposing the distal end of the catheter body through the second entry; and reforming the stylet tip by way of withdrawing the at least one elongated element from the at least one lumen, thereby minimizing trauma to the blood vessel, in accordance with an embodiment of the present disclosure.

[0024] Furthermore, a method of treatment, treating a patient, and/or inserting a catheter into a blood vessel by way of a catheter apparatus, includes providing/obtaining the catheter apparatus, the catheter apparatus comprising a catheter/catheter body having a first lumen capable of fluid communication via a first distal opening and a second lumen capable of fluid communication via a second distal opening; the catheter apparatus also comprising a first intra-catheter stiffener element configured for disposition through the first lumen such that a distal end thereof is distal in relation to the first distal opening, the first intra-catheter stiffener element comprising one of a guide-wire and a stylet; and the catheter apparatus comprising a second intra-catheter stiffener element configured for disposition through the second lumen such that a distal end thereof is distal in relation to the second distal opening, wherein the second intra-catheter stiffener element comprises a guide-wire and/or a stylet, wherein the first intra-catheter stiffener element and the second intra-catheter stiffener element include a first intra-catheter stiffener element distal end and the second intra-catheter stiffener element distal

end, respectively. The first lumen is configured to receive and accommodate the first intra-catheter stiffener element and/or the first intra-catheter stiffener element distal end and the second lumen is configured to receive and accommodate the second intra-catheter stiffener element and/or the second intra-catheter stiffener element distal end. The method may include creating a first entry or incision into a patient, tissue, and/or blood vessel. The method may include inserting the catheter apparatus or any portion of the catheter apparatus (e.g., the catheter and/or stiffener element). The method may include deforming the stylet tip by way of receiving and disposing at least one elongated element (e.g., a guide-wire or stylet or other stiffener element) in at least one lumen the stiffener element. The method may include disposing a distal end of the catheter/ catheter body through the first entry or incision. The method may include creating a second entry or incision into the patient, tissue, and/or blood vessel. The method may include disposing the distal end of the catheter/catheter body through the second entry. The method may include reforming the stylet tip by way of withdrawing the at least one elongated element from the at least one lumen, thereby minimizing trauma to the blood vessel, in accordance with an embodiment of the present disclosure.

[0025] Furthermore, a method of treatment, treating a patient, and/or a method of inserting a catheter into a blood vessel by way of a catheter apparatus, includes providing the catheter apparatus, including a catheter body and a plurality of stylets joined at a proximal end and disposable within the catheter body, the plurality of stylets each comprising a lumen and an expandable stylet tip, wherein each lumen of the plurality of stylets is capable of receiving at least one elongated element and facilitating fluid communication; creating a first incision into a patient; deforming the stylet tip by way of receiving and disposing the at least one elongated element in at least one lumen of the plurality of stylets; disposing a distal end of the catheter body through the first incision; creating a second incision in a patient, tissue, or blood vessel; disposing the distal end of the catheter body through the second incision; and reforming the stylet tip by way of withdrawing the at least one elongated element from the at least one lumen, thereby minimizing trauma to the blood vessel.

[0026] The embodiments described herein may be used, for example, in the field of hemodialysis, or other fields, for inserting a single-tip or a multi-tip catheter into a blood vessel. The apparatuses, systems, and methods are believed to facilitate insertion of a single-tip or a multi-tip catheter without using a tearable sheath by employing a variety of structures and techniques using enhanced stiffening and guiding features.

BRIEF DESCRIPTION OF THE DRAWING

[0027] The above, and other, aspects, features, and benefits of several embodiments of the present disclosure will be more apparent from the following Detailed Description as presented in conjunction with the following several figures of the Drawing. Corresponding reference characters or reference numerals may indicate corresponding components throughout the several figures of the Drawing. Elements in the several figures are illustrated for simplicity and clarity and have not necessarily been drawn to scale. For example, the dimensions of some elements in the figures may be emphasized relative to other elements for facilitating understanding of the various presently disclosed embodiments. Also, well-understood elements that are useful or necessary in commercially feasible embodiments are often not depicted in order to facilitate a less obstructed view of these various embodiments of the present disclosure.

[0028] FIG. 1 is a schematic diagram illustrating a partially cutaway side view of a hemodialysis catheter apparatus of a catheter insertion system, in accordance with an embodiment of the present disclosure.

[0029] FIG. 2 is a schematic diagram illustrating performing a step of a method, e.g., by using a catheter apparatus of a catheter insertion system, wherein a distal portion of a first guide-wire is inserted into a vessel, in accordance with an embodiment of the present disclosure.

[0030] FIG. 3 is a schematic diagram illustrating performing a step of a method, e.g., by using a catheter apparatus of a catheter insertion system, wherein a blood vessel dilating sheath and a distal portion of a second guide-wire are inserted into a vessel, in accordance with an embodiment of the present disclosure.

[0031] FIG. 4 is a schematic diagram illustrating performing a step of a method, e.g., by using a catheter apparatus of a catheter insertion system, wherein a catheter is disposed in a subcutaneous tunnel between a first location and a second location, in accordance with an embodiment of the present disclosure.

[0032] FIG. 5 is a schematic diagram illustrating performing a step of a method, e.g., by using a catheter apparatus of a catheter insertion system, wherein the first guide-wire is threaded through a first lumen of a catheter assembly, and wherein the catheter assembly has

an intra-catheter stiffener element is disposed in each lumen of the catheter, in accordance with an embodiment of the present disclosure.

[0033] FIG. 6 is a schematic diagram illustrating performing a step of a method, e.g., by using a catheter apparatus of a catheter insertion system, wherein the second guide-wire is threaded through the second lumen of the catheter assembly to a point where two loops of guide-wire remain to facilitate placement of the distal end of the catheter in the vessel, in accordance with an embodiment of the present disclosure.

[0034] FIG. 7 is a schematic diagram illustrating performing a step of a method, e.g., by using a catheter apparatus of a catheter insertion system, wherein the catheter assembly has been advanced along the guide-wires until the distal portion of the catheter is positioned within the vessel at a desired location, in accordance with an embodiment of the present disclosure.

[0035] FIG. 8 is a schematic diagram illustrating performing a step of a method, e.g., by using a catheter apparatus of a catheter insertion system, as shown in FIG. 7, wherein the intra-catheter stiffener elements and guide-wires removed, in accordance with an embodiment of the present disclosure.

[0036] FIG. 9 is a schematic diagram illustrating performing a step of a method, e.g., by using a catheter apparatus of a catheter insertion system, wherein a retrograde catheter is shown having a distal end disposed in a vessel, in accordance with an embodiment of the present disclosure.

[0037] FIG. 10 is a schematic diagram illustrating performing a step of a method, e.g., by using a catheter apparatus of a catheter insertion system, wherein the catheter has been subcutaneously tunneled subsequent to placement of the distal end of the catheter in a vessel, in accordance with an embodiment of the present disclosure.

[0038] FIG. 11 is a schematic diagram illustrating performing a step of connecting fluid couplers to a hemodialysis machine, e.g., in a method of inserting/using a catheter body by way of a catheter system, in accordance with an embodiment of the present disclosure.

[0039] FIG. 12 is a schematic diagram illustrating an exemplary kit for installing a catheter or catheters by using a catheter apparatus, e.g., of a catheter insertion system, in accordance with an embodiment of the present disclosure.

[0040] FIG. 13 is a schematic diagram illustrating a perspective view of a catheter apparatus, e.g., of a catheter insertion system, in accordance with an embodiment of the present disclosure.

[0041] FIG. 14 is a schematic diagram illustrating a side view of a catheter apparatus, e.g., of a catheter insertion system, in accordance with an embodiment of the present disclosure.

[0042] FIG. 15 is a schematic diagram illustrating a perspective view of a catheter apparatus, e.g., of a catheter insertion system, in accordance with an embodiment of the present disclosure.

[0043] FIG. 16 is a schematic diagram illustrating a perspective view of a catheter apparatus, e.g., of a catheter insertion system, in accordance with an embodiment of the present disclosure.

[0044] FIG. 17 is a schematic diagram illustrating a perspective view of a catheter apparatus, e.g., of a catheter insertion system, in accordance with an embodiment of the present disclosure.

[0045] FIG. 18 is a schematic diagram illustrating a perspective view of a catheter apparatus, e.g., of a catheter insertion system, in accordance with an embodiment of the present disclosure.

[0046] FIG. 19 is a schematic diagram illustrating a cutaway side view of a catheter apparatus, e.g., of a catheter insertion system, comprising a catheter body having two lumens, a single stylet disposed through one lumen; and a single guide-wire disposed through the other lumen, a distal end of the guide-wire being disposed through a distal end of the stylet, such as useable in a catheter system, in accordance with an embodiment of the present disclosure.

[0047] FIG. 20A is a schematic diagram illustrating a cutaway top view of a catheter apparatus, e.g., of a catheter insertion system, comprising a catheter body having two lumens separated by a septum, a single stylet disposed through one lumen; and a single guide-wire (not shown) may also be disposed through the other lumen, a distal end of the guide-wire being disposable within at least one portion of the stylet, such as useable in a catheter system, in accordance with an embodiment of the present disclosure.

[0048] FIG. 20B is a schematic diagram illustrating a cutaway side view of a catheter apparatus, e.g., of a catheter insertion system, comprising a catheter body having two lumens separated by a septum, a single stylet disposed through one lumen; and a single guide-wire (not shown) may be disposed through the other lumen, a distal end of the guide-wire being disposable within at least one portion of the stylet, such as useable in a catheter system, in accordance with an embodiment of the present disclosure.

[0049] FIG. 21A is a schematic diagram illustrating a cutaway top view of a catheter apparatus, e.g., of a catheter insertion system, comprising a catheter body having two lumens separated by a septum, a guide-wire disposed through a first lumen, wherein the guide-wire distal end includes a looped portion, in accordance with an embodiment of the present disclosure.

[0050] FIG. 21B is a schematic diagram illustrating a cutaway side view of the catheter apparatus of FIG. 21A, comprising a catheter body having two lumens separated by a septum, a guide-wire disposed through each lumen; a distal end of one guide-wire being disposable through a looped portion of the distal end of the other guide-wire, in accordance with an embodiment of the present disclosure.

[0051] FIG. 22 is schematic diagram illustrating a cutaway perspective view of a catheter apparatus, e.g., of a catheter insertion system, wherein a stylet is adapted to accommodate a guide-wire, such as by weaving through a portion thereof, in accordance with an embodiment of the present disclosure.

[0052] FIG. 23 is schematic diagram illustrating another cutaway perspective view of the catheter apparatus, e.g., of a catheter insertion system, as shown in FIG. 22, wherein a stylet is adapted to accommodate a guide-wire, such as by weaving through a portion thereof, in accordance with an embodiment of the present disclosure.

[0053] FIG. 24 is schematic diagram illustrating a cutaway perspective view of a catheter apparatus, e.g., of a catheter insertion system, wherein a guide-wire is woven through a portion of a stylet, in accordance with an embodiment of the present disclosure.

[0054] FIG. 25 is schematic diagram illustrating another cutaway perspective view of the catheter apparatus, e.g., of a catheter insertion system, as shown in FIG. 24, wherein a

guide-wire is woven through a portion of a stylet, in accordance with an embodiment of the present disclosure.

[0055] FIG. 26 is schematic diagram illustrating a cutaway side view of a catheter apparatus, e.g., of a catheter insertion system, in accordance with an embodiment of the present disclosure.

[0056] FIG. 27 is schematic diagram illustrating a cutaway side view of a catheter apparatus, e.g., of a catheter insertion system, as shown in FIG. 26, wherein a guide-wire is woven through a portion of a stylet, in accordance with an embodiment of the present disclosure.

[0057] FIG. 28 is a schematic diagram illustrating a partially cutaway side view of a plurality of stylets, such as two stylets, joined at a proximal end, e.g., for use in a catheter system, in accordance with an embodiment of the present disclosure.

[0058] FIG. 29 is a schematic diagram illustrating a partially cutaway side view of a stylet of a plurality of stylets, e.g., for a hemodialysis catheter insertion system, each stylet of the plurality of stylets comprising tip having a hemi-toroidal configuration, rather than a tapered tip, in accordance with an embodiment of the present disclosure.

[0059] FIG. 30 is a schematic diagram illustrating a cut-away perspective view of an expandable catheter insertion system, having a stylet in an unexpanded condition, in accordance with an embodiment of the present disclosure.

[0060] FIG. 31 is a schematic diagram illustrating an exploded cut-away perspective view of an expandable catheter insertion system, having a stylet in an unexpanded condition, in accordance with an embodiment of the present disclosure.

[0061] FIG. 32 is a schematic diagram illustrating a cut-away top view of an expandable catheter insertion system, having a stylet in an unexpanded condition, in accordance with an embodiment of the present disclosure.

[0062] FIG. 33 is a schematic diagram illustrating a cut-away top view of an expandable catheter insertion system, having a stylet in an expanded condition and a guide-wire disposed therethrough, the guide-wire facilitating expansion of the stylet, in accordance with an embodiment of the present disclosure.

[0063] FIG. 34 is a schematic diagram illustrating a cut-away side view of an expandable catheter insertion system, having a stylet in an unexpanded condition, wherein the stylet includes at least one slit for facilitating expansion, in accordance with an embodiment of the present disclosure.

[0064] FIG. 35 is a schematic diagram illustrating a cut-away side view of an expandable catheter insertion system, having a stylet in an expanded condition, in accordance with an embodiment of the present disclosure.

[0065] FIG. 36 is a schematic diagram illustrating a cut-away side view of a catheter insertion system, having a stylet in an expanded condition and a guide-wire disposed therethrough, the guide-wire facilitating expansion of the stylet, in accordance with an embodiment of the present disclosure.

[0066] FIG. 37 is a schematic diagram illustrating a cut-away perspective view of a catheter insertion system, having a stylet in an expanded condition and a guide-wire disposed therethrough, the guide-wire facilitating expansion of the stylet, in accordance with an embodiment of the present disclosure.

DETAILED DESCRIPTION

[0067] Referring to FIG. 1, this schematic diagram illustrates, in a partially cutaway side view, a catheter system **10**, such as a hemodialysis catheter insertion system, in accordance with an embodiment of the present disclosure. The catheter system **10** includes a catheter body **12** with two internal lumens **14A** and **14B**. The catheter body **12** has a “split-tip” distal end **16** in which the body (and lumens) separate into two distal tip portions, **18A** and **18B**, which form a single-lumen distal blood return extension tube and a single-lumen distal blood removal extension tube, respectively. The split-tips can, but need not have, one or more side ports **20A** and **20B**, in fluid communication with one or the other of the lumens **14A** and **14B** to facilitate respective blood return and removal during hemodialysis.

[0068] Still referring to FIG. 1, alternatively, or in conjunction with side ports, the distal ends **16** can be open to provide fluid passageways for blood removal and return. The proximal end **22** of the catheter body **12** can also be split into separate segments **22A** and **22B** and terminate with two couplers **28A** and **28B**, which can include couplings **34A** and **34B**, such as luer-locks or the like, to couple the catheter system **10** to a hemodialysis machine (not shown)

in which blood is circulated and purified. Proximal segments **22A**, **22B**, thus, respectively provide a single-lumen proximal blood return extension tube and a single-lumen proximal blood removal extension tube. However, an additional lumen or lumens are also possible.

[0069] Still referring to FIG. 1, the overall system or kit of the present disclosure can also include two intra-catheter stiffener elements **51A** and **51B** each of which can include either one or more stylets **24A**, **24B** respectively, or one or more guide-wires **26A**, **26B** respectively, or both a stylet and a guide-wire whereby the guide wires **26A**, **26B** are disposed within stylets **24A**, **24B** respectively, and are shown within the respective lumens **14A** and **14B**. The catheter body **12** is typically a very flexible silicone, polyurethane, or other biocompatible composition, e.g., having a stiffness in the range of about 65 to about 85 durometers. Preferably, the stylets **24A**, **24B** comprise a stiffer form of polyethylene or other bio-compatible material. In addition to stiffening the assembly, the stylets **24A**, **24B** facilitate preventing kinking of the catheter body **12** during insertion.

[0070] Still referring to FIG. 1, the catheter apparatus **10** of a catheter system facilitates insertion of the distal end of the multi-lumen, split-tip, flexible catheter body **12** into a blood vessel using the stylets **24A**, **24B** and guide-wires **26A**, **26B**, as will be explained below. Briefly, a distal portion of each guide-wire **26A**, **26B** is disposed at a desired position within the vessel. A stylet **24A**, **24B** having a tapered tip to facilitate insertion into the vessel and to provide catheter stiffening is slidably disposed along the length of each catheter lumen **14A**, **14B** until it extends beyond the distal tip of that catheter lumen **14A**, **14B**. A proximal end of each guide-wire **26A**, **26B** is threaded through a distal end of a lumen **14A**, **14B** extending along each of the stylets **24A**, **24B**. The catheter body **12** is then advanced over the guide-wires **26A**, **26B** and into a blood vessel **4** (FIG. 2). Optionally, the catheter body **12** can be advanced over the guide-wires **26A**, **26B** until the distal end is adjacent to the vessel, at which point the catheter body **12** and guide-wires **26A**, **26B** can be advanced together into the blood vessel. The guide-wires **26A**, **26B** and stylets **24A**, **24B** are then removed from the catheter body **12**. The methods and application kit described can be used for any split-tip catheter, and are particularly useful for insertion of subcutaneously tunneled hemodialysis catheters, as contemplated by the present disclosure.

[0071] Referring to FIGS. 2-11, these schematic diagrams, together, illustrate various steps in one or more methods of inserting a catheter body **12** by way of a catheter apparatus **10** of a catheter system, such as a multi-lumen split-tip catheter having at least one enhanced stylet,

into a blood vessel, in accordance with an embodiment of the present disclosure. The method involves, not only inserting the catheter tips into a blood vessel, but also forming a subcutaneous tunnel below a patient's skin to secure the catheter body **12** in place and is sometimes described as antegrade or forward insertion. The methods described herein can also be used for inserting catheter tips into a blood vessel where tunneling is not necessary or desired, as encompassed by the present disclosure.

[0072] Referring to FIG. 2, this schematic diagram illustrates performing a step, e.g., an initial step, of an inserting method, wherein a distal portion of a first guide-wire **26A** is inserted into a vessel **4**, such as a blood vessel, of a patient **2**, in accordance with an embodiment of the present disclosure. The entry location **6** of the guide-wire **26A** is referred herein as the "first location" or the "venotomy site." This first location is typically a surgical incision that provides access to the desired blood vessel which typically includes the internal or external jugular, femoral or subclavian vein, and the vena cava, for example. In a preferred embodiment, the blood vessel chosen for catheter placement can be the right side internal jugular vein.

[0073] Referring to FIG. 3, this schematic diagram illustrates performing a step of an inserting method, wherein a blood vessel dilating sheath **30** and a distal portion of a second guide-wire **26B** are inserted into a vessel **4**, such as a blood vessel, of a patient **2**, in accordance with an embodiment of the present disclosure. The blood vessel sheath/dilator **30** is shown as inserted over the first guide-wire **26A** to dilate the vessel **4**.

[0074] Referring to FIG. 4, this schematic diagram illustrates performing a step of an inserting method, wherein an antegrade catheter is disposed in a subcutaneous tunnel **40** between a first location **6** and a second location **32**, in accordance with an embodiment of the present disclosure. The subcutaneous tunnel **40** is formed (before or after the insertion of guide-wires **26A** and **26B**) to anchor the catheter body **12** in place and to provide two couplers **28A**, **28B** for coupling the two lumens **14A**, **14B** of the catheter system **10** to a dialysis machine (not shown) using couplings **34A**, **34B**. The catheter body **12** of an antegrade catheter is disposed in a subcutaneous tunnel **40** between the first (venous access) location **6** and a second (exit) location **32**, such that the distal end of the instrument **16** including the split tips **18A** and **18B** extend from the first location **6**. Prior to insertion, each of the lumens **14A**, **14B** of catheter body **12** has been fitted with a hollow, tubular, intra-catheter stiffener element or liner, such as stylets **24A** and **24B**, respectively.

[0075] Referring to FIG. 5, this schematic diagram illustrates performing a step of an inserting method, wherein the first guide-wire **26A** is threaded through a first lumen **14A** of a catheter system **10**, and wherein the catheter system **10** has stylets **24A** and **24B** disposed in each lumen **14A**, **14B** of the catheter body **12**, in accordance with an embodiment of the present disclosure. The first guide-wire **26A** is threaded through a first lumen **14A** of a catheter system **10**, e.g., through the lumen **14A** associated with the stylet **24A**, and wherein the catheter system **10** has a stylet **24A** and a stylet **24B** disposed in each lumen **14A**, **14B** of the catheter body **12**.

[0076] Referring to FIG. 6, this schematic diagram illustrates performing a step of an inserting method, wherein the second guide-wire **26B** is threaded through the second lumen **14B** of the catheter apparatus **10** to a point where two loops of guide-wire remain to facilitate placement of the distal end of the catheter body **12** in the vessel **4**, in accordance with an embodiment of the present disclosure. The second guide-wire **26B** is threaded through the second lumen **14B** of the catheter system **10**, e.g., through the lumen **14B** associated with the stylet **24B**. Each of the guide-wires **26A**, **26B** is advanced through the catheter body **12** to a point where two short loops of guide-wire **26A**, **26B** remain to facilitate placement of the distal end of the catheter body **16** in the vessel **4**.

[0077] Referring to FIG. 7, this schematic diagram illustrates performing a step of an inserting method, wherein the catheter system **10** has been advanced along the guide-wires **26A**, **26B** until the distal portion of the catheter body **12** is positioned within the vessel **4** at a desired location, in accordance with an embodiment of the present disclosure. In a preferred embodiment, the catheter body **12** is advanced over the guide-wires **26A**, **26B** until the distal end is adjacent to the vessel **4**, and then the catheter body **12** and the guide-wires **26A**, **26B** can be advanced together until the distal end of the catheter body **12** is positioned at a desired position within the vessel **4**. The guide-wires **26A**, **26B** can then be removed by withdrawing them via the proximal end **22** of the catheter body **12**. Likewise, the stylets **24A**, **24B** can be removed (either subsequent to or before the guide-wires **26A**, **26B** or at the same time). Advantageously, this method precludes using a vessel dilator larger than the catheter/stiffeners assembly for placement of the catheter body **12** within the vessel **4** since the stylets **24A**, **24B** and the catheter body **12** themselves provide vessel dilation.

[0078] Referring to FIG. 8, this schematic diagram illustrates performing a step of an inserting method, as shown in FIG. 7, wherein the stylets **24A**, **24B** and guide-wires **26A**, **26B** are removed, in accordance with an embodiment of the present disclosure. The venous access

incision or entry location **6** is then closed and the catheter body **12** is secured subcutaneously (e.g., via an implanted cuff and/or sutures).

[0079] Referring back to FIGS 2-8 and forward to FIGS. 9 and 10, although the above detailed description has been presented in connection with an antegrade insertion, the apparatuses, systems, and methods of the present disclosure are also useful in retrograde or reverse insertions, e.g., wherein the catheter body **12** is passed through the subcutaneous tunnel **40** from the venotomy site **6** to the remote exit location, such as a second (exit) location **32**. Thus, the method, according to one embodiment of the present disclosure, for insertion of a retrograde catheter will next be described. For the method, an initial step of inserting a retrograde catheter begins with placement of guide-wires **26A**, **26B** within the vessel **4** as described above in connection with FIGS. 2 and 3.

[0080] Referring to FIG. 9, this schematic diagram illustrates performing a step of an inserting method, wherein a retrograde catheter is shown having a distal end disposed in a vessel **4**, in accordance with an embodiment of the present disclosure. The catheter body **12** has each of the lumens **14A**, **14B** fitted with a hollow, tubular, intra-catheter stiffener element or liner, such as a stylet **24A** and **24B**, respectively. The stylets **24A**, **24B** can have a coupler, such as fluid-couplers **28A**, **28B**, disposed at a proximal end that releasably couple with a mating coupler at a proximal end of the respective catheter lumen **14A**, **14B**. The guide-wires **26A**, **26B** are threaded through the lumens **14A**, **14B** of the catheter system **10** as described above in relation to FIGS. 5 and 6. The catheter body **12** is advanced along the guide-wires **26A**, **26B** until the distal end of the catheter body **12** in a desired location within the vessel **4**. Optionally, the catheter body **12** can be advanced along the guide-wires **26A**, **26B** until the distal end is adjacent to the vessel **4**, and then the catheter body **12** and the guide-wires **26A**, **26B** can be advanced until the distal end is located at a desired position within the vessel **4**. The guide-wires **26A**, **26B** and, optionally, the stylets **24A**, **24B** are then removed from the lumens **14A**, **14B**.

[0081] Referring to FIG. 10, this schematic diagram illustrates performing a step of an inserting method, wherein the catheter body **12** has been subcutaneously disposed in a subcutaneous tunnel subsequent to the distal end of the catheter body **12** being disposed in a vessel, in accordance with an embodiment of the present disclosure. A subcutaneous tunnel **40** is formed between a second location, e.g., the exit location **32**, and the first location, e.g., the venotomy site **6**. Couplers at the proximal end **22** of the catheter lumens **14A**, **14B** are removed

94, 96 or optionally, severed therefrom to allow the proximal end **22** of the catheter body **12** to be pulled through the tunnel **40**. In an embodiment, the proximal end **22** of the catheter body **12** is pulled through the subcutaneous tunnel **40** from the first location, e.g., the venotomy site **6**, until the catheter body **12** extends from the second location, e.g., the exit location **32**. Fluid couplers (e.g., couplers **28A, 28B** as shown in FIG. 11) may be installed/added to the catheter body **12**, e.g., after placement in the subcutaneous tunnel, wherein the coupler installing/adding step may include disposing fluid-couplers **28A, 28B** in relation to at least one proximal end **22** of the catheter body **12**.

[0082] Referring to FIG. 11, this schematic diagram illustrates performing a step of connecting fluid couplers **28A, 28B** to a hemodialysis machine **80**, in a method of inserting a catheter body **12** by way of a catheter system **10**. The catheter body **12**, after disposing through the tunnel **40** with fluid-couplers **28A, 28B** being installed, or optionally, replaced, is ready to be coupled to a hemodialysis machine **80** for blood purification, such as by way of fluid lines **82, 84**. The stiffener elements, including stylets **24A, 24B** and/or guide-wires **26A, 26B** may be removed prior to coupling to the hemodialysis machine **80**. An ingrowth cuff **86** facilitates tissue growth to secure catheter body **12** within the subcutaneous tunnel **40**. As noted above, the use of the stylets **24A, 24B** provides sufficient stiffness such that the flexible split-tips can be slid over the guide-wires **26A, 26B** into the desired position with less effort and reduced likelihood of trauma to the patient. Catheter kinking is mitigated during the inserting method, thus reducing complexity of catheter insertion.

[0083] Referring to FIG. 12, this schematic diagram illustrates a catheter kit **48** for installing catheters, such as catheter bodies **12** of catheter systems **10**, in accordance with an embodiment of the present disclosure. In FIG. 12 catheter bodies **12** are generic representations that can correspond to a wide variety of catheter types and shapes, including any of the catheter types or shapes shown in other figures herein. The catheter kit **48** includes equipment for performing the steps of the method, as at least above described. By example only, the catheter kit **48** includes two stylets **24A, 24B**, two guide-wires **26A, 26B**, a “6-French” sheath/dilator **54**, and two vessel dilators **56, 58**, each of the vessel dilators having a distinct size from the other vessel dilator. Other arrangements are contemplated and are within the scope of the present disclosure, each having at least two stylets **24A, 24B**. For example, in one embodiment, the catheter kit **48** includes a catheter body **12** having a split-tip catheter and two stylets **24A,**

24B. The catheter kit **48** is suitable for inserting either antegrade or retrograde catheter configurations, in accordance with at least one embodiment of the present disclosure.

[0084] Still referring to FIG. 12, stylets **24A**, **24B** are illustrated as “5-French” in size and of the same length, by example only. However, stylets **24A**, **24B** need not be of the same size and length, but can be selected according to the size and length of the catheter to be inserted. Further, stylets **24A**, **24B** need not have a round exterior shape, but rather, can have an external shape according to the size and shape of an interior of a catheter lumen **14A**, **14B**, for example, oval shaped. In a preferred embodiment, each stylet **24A**, **24B** has a tapered configuration along a distal portion to aid in dilating the catheter lumen **14A**, **14B**, with a releasable coupler **60** at a proximal end **59**, such as a luer-coupler. Each stylet **24A**, **24B** has a hollow bore for accommodating a lumen running along its length sized to slidably receive a guide-wire **26A**, **26B** as above described. Each stylet **24A**, **24B** preferably has a stiffness in a range that is sufficient to prevent the catheter body **12** from kinking or otherwise distorting during the insertion procedure. The stylets **24A**, **24B** can be components in the catheter kit **48**, be separately provided, or be predisposed within the catheter lumens **14A**, **14B**.

[0085] Still referring to FIG. 12, the guide-wires **26A**, **26B** are illustrated as “J-straight” 0.038-inch guide-wires by example only; however, each guide-wire **26A**, **26B** can vary according to the application and catheter configuration. Each guide-wire **26A**, **26B** can have a removable sheath to accommodate handling and facilitate placement within a desired location such as a vein. The sheath/dilator **54** is illustrated as having size of “6-French;” however, other sizes may be used to puncture a wall of a vessel and accommodate one or more guide-wires **26A**, **26B**. The dilators **56**, **58** are illustrated as having size of “14-French” and “16-French,” respectively; and the dilators **56**, **58** are suitable for many catheter insertion procedures. In a preferred embodiment, a size of “12-French” is provided in addition to, or instead of, one of the illustrated dilators **56**, **58**. The above apparatuses, systems, methods, and kits are useful for inserting hemodialysis catheters in a patient, and, in general, for multi-lumen split-tip catheters intended for other functions where body fluids are extracted and introduced. As such, the present disclosure is not limited to those embodiments described above, but rather, is limited by the claims that follow.

[0086] FIGS. 13-18 show distal ends of additional catheters for use with the intra-catheter stiffener elements, stylets, and guide-wires described herein in embodiments of a

catheter insertion system. The catheter insertion systems can be included in catheter kits such as those described herein.

[0087] Referring to FIGS. 13 and 14, these schematic diagrams respectively illustrate a perspective view and a side view of a catheter apparatus **210** of a catheter insertion system, in accordance with an embodiment of the present disclosure. The catheter apparatus **210** includes a catheter body **212** having an elongated tubular configuration that extends to a distal end **199**. A catheter body **212** has a first lumen **201** and a second lumen **202**, with a septum **13** disposed therebetween. The catheter body **212** includes a first wall **203** that defines first lumen **201** and a second wall **204** that defines the second lumen **202**. A portion, such as a septum extension **13e** of the septum **13** extends distally beyond the first lumen **201** and the second lumen **204**. The septum **13** is medially disposed along a substantial portion of the longitudinal length of the catheter body **212**, between the first lumen **201** and second lumen **202**. The septum **13** is variously disposed in relation to the catheter body **212**, such as by an angular offset relative to extended portions of the first and second walls **203**, **204**.

[0088] The first wall **203** includes a first wall extension **215** that extends distally beyond first lumen **201** and is spaced apart from septum extension **13e**. The first wall extension **215** defines a concave surface **230** that faces septum extension **13e**. The second wall **204** includes a second wall extension **232** that extends distally beyond second lumen **204** and is spaced apart from septum extension **13e**. The second wall extension defines a concave surface **230** that faces septum extension **13e**. The septum extension **13e** extends beyond the first wall extension **215** and second wall extension **232**. The septum extension **13e** is medially disposed, as extending from the catheter body **212**, between the first wall extension and the second wall extension. The septum extension **13e** is variously disposed in relation to the catheter body **212**. The catheter apparatus **210** advantageously prevents occlusion of the first lumen **201** and second lumen **202**. One or a plurality of wall extensions may be employed with catheter insertion system, depending on a given catheter application.

[0089] The catheter body **212** includes a monocoque configuration, such as a cylindrical outer surface **205**. The catheter body **212** is variously dimensioned and attachable to other medical devices. The outer surface **205** includes various cross-sectional configurations, such as an oval shape, a rectangular shape, an elliptical shape, a polygonal shape, etc. The catheter body **212** may also include lateral openings. The first wall **203** has a wall surface that defines the first lumen **201** in cooperation with a surface of the septum **13**.

The second wall **204** has a wall surface that defines the second lumen **202** in cooperation with a surface of the septum **13**.

[0090] The concave surface **230** is bounded by a planar end surface **206** of first wall extension and spans a radial distance. The planar end surface **206** extends about the perimeter of the concave surface **230**, such that first wall extension **215** has a scoop-shape configuration that facilitates fluid flow through the first lumen **201**. The first wall extension **215** may form alternate configurations, such as a spherical shape, a rectangular shape, etc. The planar end surface **206** includes a radial portion adjacent a distal end of first wall extension **215**. The radial portion extends to the longitudinally oriented outer surface **200** of the catheter body **212** in an arcuate configuration. This configuration advantageously prevents a blood vessel wall (not shown) from becoming disposed within the inlet of first lumen **201**. A radial portion **207** extends to the longitudinally oriented outer surface **200** of the catheter body **212** in a perpendicular convergence. The planar end surface **206** is disposed at an angular orientation a relative to a first planar surface **208**. The planar end surface **206** may be disposed at various angular orientations. A concave surface **230** is bounded by a planar end surface **260** of second wall extension **232** and spans a radial distance. End surface **260** extends about the perimeter of concave surface **230** such that the second wall extension **232** has a scoop-like configuration that facilitates fluid flow through second lumen **202**.

[0091] The catheter apparatus **210** may be used in place of, in addition to, or in combination with the catheter apparatus **12** (of FIGS. 1–12) or other catheter apparatuses disclosed herein. Catheter systems, comprising a catheter apparatus **210**, are combinable with the features described with respect to other catheter apparatuses herein, in accordance with described embodiments of catheter systems. For example, embodiments of the intra-catheter stiffener elements described herein may be configured/shaped in such a way for disposition through the lumens **201**, **202**. A first intra-catheter stiffener element **51A** may be configured/shaped for disposition through the first lumen **201** such that a distal end thereof is distal in relation to the distal end **199**. A second intra-catheter stiffener element **51B** may be configured/shaped for disposition through the second lumen **202** such that a distal end thereof is also distal in relation to the distal end **199**. The distal end of the first intra-catheter stiffener element and the distal end of the second intra-catheter stiffener element may be capable of receiving and accommodating the other of the first intra-catheter stiffener element distal end

and the second intra-catheter stiffener element distal end as described in various embodiments herein.

[0092] Referring to FIGS. 15 and 16, these schematic diagrams illustrate, in various perspective views, catheter systems that are combinable with many of the above-described features. A catheter apparatus **310** includes a first wall **301** that includes a first wall extension **301a** that extends distally beyond a first lumen **316** and is spaced apart from a septum extension **307**. The first wall extension **301a** defines a concave surface **330** that faces the septum extension **307**. A second wall **302** includes a second wall extension **302a** that extends distally beyond a second lumen **318** and is spaced apart from the septum extension **307**. The second wall extension **302a** defines a concave surface **334** that faces the septum extension **307**.

[0093] The first wall extension **301a** includes a first step or notch **312** and a second step or notch **314** formed therewith. The first step or notch **312** is formed with the septum extension **307**. The first step or notch **312** and the second step or notch **314** are circumferentially disposed about the septum extension **307**. The first step or notch **312** and/or the second step or notch **314** may have alternate configurations, such as a planar configuration, etc. The first step or notch **312** extends distally beyond an inlet opening of the first lumen **316** and an outlet opening of the second lumen **318**. The second step or notch **314** extends distally beyond the inlet opening and the outlet opening. A concave surface **230** faces a first planar surface **308** of the septum extension **307** and is spaced apart therefrom. A concave surface **330** spans across approximately one-quarter of the circumference of the catheter body **311** or a substantially 90° arc as extended from the septum extension **307**. The first step or notch **312** and/or the second step or notch **314**, or other portions of the concave surface **330** may be variously disposed about the catheter body **311**.

[0094] The catheter apparatus **310** may be used in place of, in addition to, or in combination with the catheter apparatus **12** (of FIGS. 1–12) or other catheter apparatuses disclosed herein. Catheter systems, comprising a catheter apparatus **310**, are combinable with the features described with respect to other catheter apparatuses herein, in accordance with described embodiments of catheter systems. For example, embodiments of the intra-catheter stiffener elements described herein may be configured/shaped in such a way for disposition through the lumens **316**, **318**. A first intra-catheter stiffener element **51A** may be configured/shaped for disposition through the first lumen **316** such that a distal end thereof is distal in relation to the septum extension **307**. A second intra-catheter stiffener element **51B**

may be configured/shaped for disposition through the second lumen **202** such that a distal end thereof is also distal in relation to the septum extension **307**. The distal end of the first intra-catheter stiffener element and the distal end of the second intra-catheter stiffener element may be capable of receiving and accommodating the other of the first intra-catheter stiffener element distal end and the second intra-catheter stiffener element distal end as described in various embodiments herein.

[0095] Referring to FIGS. 17 and 18, these schematic diagrams illustrate, in various perspective views, catheter systems comprising a catheter apparatus **400** that are combinable with features described in various embodiments of the present disclosure. The distal end of the catheter apparatus **400** includes a first wall **422** having a first wall extension **405** that extends distally beyond venous lumen **401** and is spaced apart from a septum extension **407**. First wall extension **405** defines a concave surface **406** that faces septum extension **407**. A second wall **423** includes a second wall extension **410** that extends distally beyond arterial lumen **402** and is spaced apart from septum extension **407**. Second wall extension **410** defines a concave surface **409** that faces septum extension **407**.

[0096] The first wall extension **405** is circumferentially disposed about septum extension **407** in a spiral configuration to facilitate fluid flow and prevent recirculation between lumens **401**, **402**. The first wall extension **405** may include various spiral configurations, such as, for example, a more elongated spiral, a spiral having a more acute winding type design, helical, etc. First wall extension **405** extends distally beyond opening **446** of the first lumen **401** and opening **450** (not shown) of second lumen **402**. A concave surface **406** faces first planar surface **416** of septum extension **407** and is spaced apart therefrom. A concave surface **406** is bounded by a planar end surface **404** of first wall extension **405**. End surface **404** extends about the perimeter of concave surface **406** in a spiral configuration, as described above, to facilitate fluid flow through venous lumen **401**. Concave surface **406** and first planar surface **416** cooperate to define first cavity **411**. First cavity **411** is further bounded by a proximal base **412** of end surface **404**. Proximal base **412** is formed with septum extension **407** in an arcuate transition. Proximal base **412** has an arcuate configuration and defines a proximal inlet/outlet portion for venous lumen **401**. During removal of fluids, venous lumen **401** has a greater fluid flow rate adjacent proximal base **412**.

[0097] A second wall extension **410** is circumferentially disposed about septum extension **407** in a spiral configuration to facilitate fluid flow and prevent recirculation between

lumens **401**, **402**. The first wall extension **405** may include various spiral configurations, such as, for example, a more elongated spiral, a spiral having a more acute winding type design, helical, etc. Second wall extension **410** extends distally, a distance **bbb**, beyond opening **450** (not shown but similarly configured to opening **446**) and opening **446**. The distance **bbb** includes various lengths. Concave surface **409** faces second planar surface **414**, opposing first planar surface **416**, of septum extension **407** and is spaced apart therefrom. Concave surface **409** is bounded by a planar end surface **408** of second wall extension **410**. End surface **408** (similarly configured to end surface **404**, although end surfaces **404**, **408** may include alternative or distinct structure) extends about the perimeter of concave surface **409** in a spiral configuration, as described above, to facilitate fluid flow through arterial lumen **402**. Concave surface **409** and second planar surface **414** cooperate to define second cavity **413** (shown in phantom), similar to that described above. Second cavity **413** is further bounded by a proximal base of end surface **408**, which can be similarly configured to base **412**, although the bases **412** may include alternative or distinct structure. Proximal base has an arcuate configuration and defines a proximal inlet/outlet portion for arterial lumen **402** during removal of fluids. It is contemplated that that during removal of fluids, arterial lumen **402** has a greater fluid flow rate adjacent proximal base.

[0098] A first wall extension **405** and second wall extension **410** are symmetrically disposed about septum extension **407** such that first cavity **411** and second cavity **413** are symmetrical. First cavity **411** and second cavity **413** bound an equivalent space to facilitate inflow and outflow capability for each lumen. The configuration of the catheter apparatus **400** advantageously facilitates reversible flow between venous lumen **401** and arterial lumen **402** by alternating blood flow directions. As venous lumen **401** returns blood flow to the body vessel, blood flow is removed through arterial lumen **402**. The blood flow is axially directed out of cavity **411** past first wall extension **406**. Such axially directed blood flow washes away any blood clots disposed adjacent cavity **411**. Arterial lumen **402** is provided with suction to remove fluids from the body vessel. The suction draws blood flow from various directions and orientations into opening **450**. Suction is greater adjacent proximal base due to its closer proximity to a suction source (not shown). Fluid flow is greater adjacent to proximal base and therefore, advantageously disposed proximal to the blood flow being expelled from cavity **411** of venous lumen **401**. This configuration minimizes recirculation between lumens **401**, **402**. It is contemplated that blood clots, or other undesired particles, disposed adjacent cavity **413** of arterial lumen **402** may be washed away by reversing blood flow direction of lumens **401**,

402. Upon reversal of blood flow direction, blood flow is expelled from cavity **413** and the axially directed blood flow washes away blood clots, similar to that described above. Venous lumen **401** removes fluids from the body vessel and into opening **411**. Second wall extension **410** is symmetrical with first wall extension **405**, and therefore, similar to proximal base, suction is greater adjacent proximal base **412**. Fluid flow is greater adjacent to proximal base **412** and therefore, advantageously disposed proximal to the blood flow being expelled from cavity **413**. This configuration minimizes recirculation between lumens **401**, **402**.

[0099] The catheter apparatus **400** may be used in place of, in addition to, or in combination with the catheter apparatus **12** (of FIGS. 1–12) or other catheter apparatuses disclosed herein. Catheter systems, comprising a catheter apparatus **400**, are combinable with the features described with respect to other catheter apparatuses herein, in accordance with described embodiments of catheter systems. For example, embodiments of the intra-catheter stiffener elements described herein may be configured/shaped in such a way for disposition through the lumens **401**, **402**. A first intra-catheter stiffener element **51A** may be configured/shaped for disposition through the first lumen **401** such that a distal end thereof is distal in relation to the distal end of septum **407**. A second intra-catheter stiffener element **51B** may be configured/shaped for disposition through the second lumen **202** such that a distal end thereof is also distal in relation to the distal end of septum **407**. The distal end of the first intra-catheter stiffener element and the distal end of the second intra-catheter stiffener element may be capable of receiving and accommodating the other of the first intra-catheter stiffener element distal end and the second intra-catheter stiffener element distal end as described in various embodiments herein.

[00100] Referring to FIG. 19, this schematic diagram illustrates, in a cutaway side view, first and second intra-catheter stiffener elements in a catheter similar to the catheters of FIGS. 13-18, which include a septum extension. A catheter apparatus **510** includes septum extension **513e**, a catheter body **512** having two lumens **514A**, **514B**, a single stylet **524** disposed through one lumen **514A** and a single guide-wire **26B** disposed through the other lumen **514B**. A distal end **53B** of the guide-wire **26B** is disposed through a distal end **553** of the stylet **524**, by example only, in accordance with an embodiment of the present disclosure. The catheter apparatus **510** includes: a catheter body **512** comprising a first lumen **514A** capable of fluid communication via a first distal opening **515A** and a second lumen **514B** capable of fluid communication via a second distal opening **515B**; a first intra-catheter stiffener element, such

as stylet **524**, configured for disposition through the first lumen **514A** such that a distal end **553** thereof is distal in relation to the first distal opening **515A**, the first intra-catheter stiffener element **51A** comprising one of a guide-wire **26A** and a stylet **24A** (FIGS. 1-12); and a second intra-catheter stiffener element **51B** configured for disposition through the second lumen **514B** such that a distal end **53B** thereof is distal in relation to the second distal opening **515B**, the second intra-catheter stiffener element **51B** comprising a guide-wire **26B**, one of the first intra-catheter stiffener element distal end **553** and the second intra-catheter stiffener element distal end **53B** capable of receiving and accommodating the other of the first intra-catheter stiffener element distal end **553** and the second intra-catheter stiffener element distal end **53B**, in accordance with an embodiment of the present disclosure.

[00101] Referring to, the first and second intra-catheter stiffener elements herein, the second intra-catheter stiffener element includes at least one of an eye portion (not shown) and a looped portion, such as looped portion **755** (FIGS. 21A and 21B), disposed at the distal end **53A** thereof capable of receiving and facilitating disposition therethrough of the distal end **53B** of the other of the first intra-catheter stiffener element and the second intra-catheter stiffener element. The catheter body includes a septum for separating the first lumen and the second lumen from one another, the septum having a distal end extending beyond at least one of the first distal opening and the second distal opening for at least minimizing backflow into at least one of the first lumen and the second lumen.

[00102] The intra-catheter stiffener elements described herein may be configured in such a way for disposition within the lumens of any of the catheter systems described within the present disclosure. The distal end of the first intra-catheter stiffener element **53B** may be configured such that it is distal in relation to the septum extension **113e** and a distal end of the second intra-catheter stiffener element **553** may be configured such that it is also distal in relation to the distal end of septum extension **113e**. The distal end of the first intra-catheter stiffener element and the distal end of the second intra-catheter stiffener element may be capable of receiving and accommodating the other of the first intra-catheter stiffener element distal end and the second intra-catheter stiffener element distal end as described in various embodiments herein.

[00103] Referring to FIG. 20A, this schematic diagram illustrates, in a cutaway top view, a catheter apparatus **610**, comprising a catheter body **612** having two lumens **614A**, **614B** separated by a septum **613**, a first intra-catheter stiffener element, such as a single stylet **651**,

disposed through one lumen **614A**; and second intra-catheter stiffener element **51B**, such as a single guide-wire **26B** (not shown), disposed through the other lumen **614B**, a distal end **53B** of the guide-wire **26B** (not shown) being disposable within at least one portion of the stylet **651**, such as useable in a catheter system, in accordance with an embodiment of the present disclosure. The stylet **651** is configured for inserting and translating through a lumen, such as a first lumen **614A**, for rotation, such as after insertion and translation, wherein a notched portion **660** of the stylet distal portion, e.g., a cover portion **657**, is rotatable for receiving the septum **613**, whereby further structural support is provided for enhancing stiffening and guiding of the catheter body **612**, and for receiving a guide-wire, such as by way of a distal end **53B** of the guide-wire **26B** (not shown).

[00104] Referring to FIG. 20B, this schematic diagram illustrates, in a cutaway side view, a catheter apparatus **610**, comprising a catheter body **612** having two lumens **614A**, **614B** separated by a septum **613**, a first intra-catheter stiffener element, such as a single stylet **651**, disposed through one lumen **614A**; and second intra-catheter stiffener element **51B**, such as a single guide-wire **26B**, disposed through the other lumen **614B**, a distal end **53B** of the guide-wire **26B** being disposable within at least one portion of the stylet **651**, such as useable in a catheter system, in accordance with an embodiment of the present disclosure. Optionally, the guide-wire **26B** may be woven into the stylet **651** along at least a portion of the stylet **651**, whereby a smooth transition is provided for enhancing stiffening and guiding of the catheter body **612**.

[00105] Still referring to FIGS. 20A and 20B, the first intra-catheter stiffener element **651** includes a cover portion **657** at the distal end **653** thereof, the cover portion **657** capable of deployment and retraction in relation to one of the first lumen **614A** and the second lumen **614B**, and the cover portion **657** cooperatively engageable with the septum distal end **613e** for at least minimizing backflow into the one of the first lumen **614A** and the second lumen **614B**, in accordance with an embodiment of the present disclosure. The cover portion **657** is deployable and retractable via at least one technique of a rotation and a translation in relation to a longitudinal axis **A** thereof. The first intra-catheter stiffener element **51A**, such as a stylet, includes at least one of a monolithic configuration and a tapered configuration, wherein the first intra-catheter stiffener element **51A** includes a first length, wherein the second intra-catheter stiffener element **51B** includes a second length, the second length less than the first length. The cover portion **657** optionally includes at least one of a conical configuration and

an oval cross-section. The stylet, such as the stylet **24A**, includes an outer dimensions or sizes that conforms with a lumen's inner dimensions or sizes.

[00106] The intra-catheter stiffener elements described herein may be configured in such a way for disposition within the lumens of any of the catheter systems described within the present disclosure. The distal end of the first intra-catheter stiffener element **653** may be configured such that it is distal in relation to the septum extension **613e** and a distal end of the second intra-catheter stiffener element (not shown) may be configured such that it is also distal in relation to the distal end of septum extension **613e**. The distal end of the first intra-catheter stiffener element and the distal end of the second intra-catheter stiffener element may be capable of receiving and accommodating the other of the first intra-catheter stiffener element distal end and the second intra-catheter stiffener element distal end as described in various embodiments herein.

[00107] Referring to FIG. 21A, this schematic diagram illustrates, in a cutaway top view, a catheter apparatus **710**, comprising a catheter body **712** having two lumens (not shown) separated by a septum (not shown) with a distal end of septum **713e**, a first intra-catheter stiffener element **751**, such as a guide-wire **752**, disposed through a first lumen (not shown); a second intra-catheter stiffener element **51B**, such as a guide-wire **26B**, disposed through a second lumen (not shown); a distal end **53B** of one guide-wire **26B** being disposable through a distal end **753** of the other guide-wire **752**, wherein the other guide-wire distal end includes a looped portion **755**, such as useable in a catheter system, in accordance with an embodiment of the present disclosure. Optionally, at least one of the guide-wires **752**, **26B** includes a coating, the coating comprising at least one material having a low friction coefficient, such as a fluorinated polymer, e.g., polyvinylfluoride (PVF), polyvinylidene fluoride (PVDF), tetrafluoroethylene (TFE), polytetrafluoroethylene (PTFE), polychlorotrifluoroethylene (PCTFE), perfluoroalkoxy polymer (PFA, MFA), fluorinated ethylene-propylene (FEP), polyethylenetetrafluoroethylene (ETFE), polyethylenechlorotrifluoroethylene (ECTFE), perfluorinated elastomer [perfluoroelastomer] (FFPM/FFKM), fluorocarbon [chlorotrifluoroethylenevinylidene fluoride] (FPM/FKM), perfluoropolyether (PFPE), perfluorosulfonic acid (PFSA), perfluoropolyoxetane, a fluorinated hyper-branched polymer, and/or a smooth silicone material, and the like.

[00108] Referring to FIG. 21B, this schematic diagram illustrates, in a cutaway side view, a catheter apparatus **710**, comprising a catheter body **712** having two lumens (not shown)

separated by a septum (not shown) with a distal end of septum **713e**, a first intra-catheter stiffener element **751**, such as a guide-wire **752**, disposed through a first lumen **14A**; a second intra-catheter stiffener element **51B**, such as a guide-wire **26B**, disposed through a second lumen **14B**; a distal end **53B** of one guide-wire **26B** being disposable through a distal end **753** of the other guide-wire **752**, wherein the other guide-wire distal end includes a looped portion **755**, such as useable in a catheter system, in accordance with an embodiment of the present disclosure.

[00109] The intra-catheter stiffener elements described herein may be configured in such a way for disposition within the lumens of any of the catheter systems described within the present disclosure. The distal end of the first intra-catheter stiffener element **53B** may be configured such that it is distal in relation to the septum extension **713e** and a distal end of the second intra-catheter stiffener element **751** may be configured such that it is also distal in relation to the distal end of septum extension **713e**. The distal end of the first intra-catheter stiffener element and the distal end of the second intra-catheter stiffener element may be capable of receiving and accommodating the other of the first intra-catheter stiffener element distal end and the second intra-catheter stiffener element distal end as described in various embodiments herein.

[00110] Referring back to FIGS. 19 through 21B, the first intra-catheter stiffener element includes a first coupler, such as a fluid-coupler, at a proximal end thereof; and the second intra-catheter stiffener element includes a second coupler, such as a fluid-coupler, at a proximal end thereof, wherein the distal end of the first intra-catheter stiffener element is distal in relation to the distal end of the second intra-catheter stiffener element when the first coupler and second coupler are coupled to the catheter body, wherein the first coupler of the first intra-catheter stiffener element mates with a first mating coupler (not shown) at a first proximal opening of the catheter body, and wherein the second coupler of the second intra-catheter stiffener element mates with a second mating coupler (not shown) at a second proximal opening of the catheter body.

[00111] The first intra-catheter stiffener elements herein may include an exterior cross-sectional shape complementing an interior cross-sectional shape of the first lumen; and the second intra-catheter stiffener element may include an exterior cross-sectional shape complementing an interior cross-sectional shape of the second lumen, wherein the exterior cross-sectional shape of the first intra-catheter stiffener element includes one of a round shape,

an oval shape, an elliptical shape, and an ogivoidal shape, and wherein the exterior cross-sectional shape of the second intra-catheter stiffener element includes one of a round shape, an oval shape, an elliptical shape, and an ogivoidal shape. Other cross-sectional shapes are contemplated and are within the scope of the present disclosure.

[00112] Referring to FIG. 22, this schematic diagram illustrates, in a cutaway perspective view, a catheter apparatus **810** of a catheter insertion system, comprising a catheter body **812** having two lumens **814A**, **814B** separated by a septum **813**, a first intra-catheter stiffener element **851A**, such as a single stylet **824A**, disposed through one lumen **814A**; and second intra-catheter stiffener element **51B**, such as a single guide-wire **26B** (FIGS. 24 and 25), disposable through the other lumen **814B**, a distal end **53B** of the guide-wire **26B** (FIGS. 24 and 25) being disposable within at least one portion of the stylet **824A**, such as useable in a catheter system, in accordance with an embodiment of the present disclosure.

[00113] The guide-wire **26B** is insertable, e.g., “weavable” or “threadable,” into the stylet **824A** along at least a portion thereof, whereby a smooth transition is provided for enhancing stiffening and guiding of the catheter body **812**. The stylet **824A** is configured for inserting and translating through a lumen, such as the lumen **814A** or the lumen **814B**, for rotation, such as after insertion and translation, wherein a notched portion **860** of the stylet distal portion, e.g., a cover or overhang portion **857**, is rotatable for optionally receiving the septum **813**, e.g., if the septum **813** includes a septum distal end **13e** extending from the septum **813** (FIGS. 13-15B), whereby further structural support is provided for enhancing stiffening and guiding of the catheter body **812**, and for receiving a guide-wire (FIGS. 24 and 25), such as by way of a distal end **53B** of the guide-wire **26B** through a first orifice **862** and a second orifice **864** of the first intra-catheter stiffener element **851A**, such as a single stylet **824A**.

[00114] Referring to FIG. 23, this schematic diagram illustrates, in another cutaway perspective view, the catheter apparatus **810** of a catheter insertion system, as shown in FIG. 24, comprising a catheter body **812** having two lumens **814A**, **814B** separated by a septum **813**, a first intra-catheter stiffener element **851A**, such as a single stylet **824A**, disposed through one lumen **814A**; and second intra-catheter stiffener element **51B**, such as a single guide-wire **26B** (FIGS. 24 and 25), disposable through the other lumen **814B**, a distal end **53B** of the guide-wire **26B** (FIGS. 24 and 25) being disposable within at least one portion of the stylet **824A**, such as useable in a catheter system, in accordance with an embodiment of the present disclosure. The stylet **824A** is inserted through one of the catheter lumens **814A**, **814B** parallel

to the septum wall, then rotated prior to guide-wire passage through the distal tip of the stylet **824A**.

[00115] The guide-wire **26B** is insertable, e.g., “weavable” or “threadable.” into the stylet **824A** along at least a portion thereof, whereby a smooth transition is provided for enhancing stiffening and guiding of the catheter body **812**. The stylet **824A** is configured for inserting and translating through a lumen, such as the lumen **814A** or the lumen **814B**, for rotation, such as after insertion and translation, wherein a notched portion **860** of the stylet distal portion, e.g., a cover or overhang portion **857**, is rotatable for optionally receiving the septum **813**, e.g., if the septum **813** includes a septum distal end **13e** extending from the septum **813** (FIGS. 13-15B), whereby further structural support is provided for enhancing stiffening and guiding of the catheter body **812**, and for receiving a guide-wire (FIGS. 24 and 25), such as by way of a distal end **53B** of the guide-wire **26B** through a first orifice **862** and a second orifice **864** of the first intra-catheter stiffener element **851A**, such as a single stylet **824A**.

[00116] One of the first intra-catheter stiffener element **851A** and the second intra-catheter stiffener element **51B** includes a cover or overhang portion **857** at the distal end **866** thereof, the cover portion **857** capable of deployment and retraction in relation to one of the first lumen **814A** and the second lumen **814B**, and the cover portion **857** cooperatively engageable with the septum distal end **13e**, if any, for at least minimizing backflow into the one of the first lumen **814A** and the second lumen **814B**, in accordance with an embodiment of the present disclosure. The cover portion **857** is deployable and retractable via at least one technique of a rotation and a translation in relation to a longitudinal axis **A** thereof (FIGS. 14a and 14B). The first intra-catheter stiffener element **851A**, such as a stylet, includes at least one of a monolithic configuration and a tapered configuration, wherein the first intra-catheter stiffener element **851A** includes a first length, wherein the second intra-catheter stiffener element **51B** includes a second length, the second length less than the first length. The cover portion **857** includes a first orifice **862** and a second orifice **864** for accommodating the guide-wire **26B** (FIGS. 24 and 25) and optionally includes at least one of a conical or frusto-conical configuration and an oval cross-section. The stylet, such as the stylet **824A**, includes an outer dimensions or sizes that conforms with a lumen’s inner dimensions or sizes.

[00117] Referring to FIG. 24, this schematic diagram illustrates, in a cutaway perspective view, a catheter apparatus **810** of a catheter insertion system, comprising a catheter body **812** having two lumens **814A**, **814B** separated by a septum **813**, a first intra-catheter

stiffener element **851A**, such as a single stylet **824A**, disposed through one lumen **814A**; and second intra-catheter stiffener element **51B**, such as a single guide-wire **26B**, disposed through the other lumen **814B**, a distal end **53B** of the guide-wire **26B** being disposable within at least one portion of the stylet **824A**, such as useable in a catheter system, in accordance with an embodiment of the present disclosure.

[00118] The guide-wire **26B** is “woven” into the stylet **824A** along at least a portion thereof, whereby a smooth transition is provided for enhancing stiffening and guiding of the catheter body **812**. The stylet **824A** is configured for inserting and translating through a lumen, such as the lumen **814A** or the lumen **814B**, for rotation, such as after insertion and translation, wherein a notched portion **860** of the stylet distal portion, e.g., a cover or overhang portion **857**, is rotatable for optionally receiving the septum **813**, e.g., if the septum **813** includes a septum distal end **13e** extending from the septum **813** (FIGS. 13-14), whereby further structural support is provided for enhancing stiffening and guiding of the catheter body **812**, and for receiving a guide-wire, such as by way of a distal end **53B** of the guide-wire **26B** through a first orifice **862** and a second orifice **864** of the first intra-catheter stiffener element **851A**, such as a single stylet **824A**.

[00119] Referring to FIG. 25, this schematic diagram illustrates, in another cutaway perspective view, the catheter apparatus **810** of a catheter insertion system, as shown in FIG. 24, comprising a catheter body **812** having two lumens **814A**, **814B** separated by a septum **813**, a first intra-catheter stiffener element **851A**, such as a single stylet **824A**, disposed through one lumen **814A**; and second intra-catheter stiffener element **51B**, such as a single guide-wire **26B**, disposed through the other lumen **814B**, a distal end **53B** of the guide-wire **26B** being disposable within at least one portion of the stylet **824A**, such as useable in a catheter system, in accordance with an embodiment of the present disclosure.

[00120] The guide-wire **26B** is “woven” into the stylet **824A** along at least a portion thereof, whereby a smooth transition is provided for enhancing stiffening and guiding of the catheter body **812**. The stylet **824A** is configured for inserting and translating through a lumen, such as the lumen **814A** or the lumen **814B**, for rotation, such as after insertion and translation, wherein a notched portion **860** of the stylet distal portion, e.g., a cover or overhang portion **857**, is rotatable for optionally receiving the septum **813**, e.g., if the septum **813** includes a septum distal end **13e** extending from the septum **813** (FIGS. 13-15B), whereby further structural support is provided for enhancing stiffening and guiding of the catheter body **812**, and for

receiving a guide-wire, such as by way of a distal end **53B** of the guide-wire **26B** through a first orifice **862** and a second orifice **864** of the first intra-catheter stiffener element **851A**, such as a single stylet **824A**.

[00121] One of the first intra-catheter stiffener element **851A** and the second intra-catheter stiffener element **51B** includes a cover or overhang portion **857** at the distal end **866** thereof, the cover portion **857** capable of deployment and retraction in relation to one of the first lumen **814A** and the second lumen **814B**, and the cover portion **857** cooperatively engageable with the septum distal end **13e**, if any, for at least minimizing backflow into the one of the first lumen **814A** and the second lumen **814B**, in accordance with an embodiment of the present disclosure. The cover portion **857** is deployable and retractable via at least one technique of a rotation and a translation in relation to a longitudinal axis **A** thereof (FIGS. 14a and 14B). The first intra-catheter stiffener element **851A**, such as a stylet, includes at least one of a monolithic configuration and a tapered configuration, wherein the first intra-catheter stiffener element **851A** includes a first length, wherein the second intra-catheter stiffener element **51B** includes a second length, the second length less than the first length. The cover portion **857** includes a first orifice **862** and a second orifice **864** for accommodating the guide-wire **26B** and optionally includes at least one of a conical or frusto-conical configuration and an oval cross-section. The stylet, such as the stylet **824A**, includes an outer dimensions or sizes that conforms with a lumen's inner dimensions or sizes.

[00122] Referring to FIG. 26, this schematic diagram illustrates, in a cutaway side view, a catheter apparatus **810** of a catheter insertion system, comprising a catheter body **812** having two lumens **814A**, **814B** separated by a septum **813**, a first intra-catheter stiffener element **851A**, such as a single stylet **824A**, disposed through one lumen **814A**; and second intra-catheter stiffener element **51B**, such as a single guide-wire **26B** (FIGS. 24 and 25), disposable through the other lumen **814B**, a distal end **53B** of the guide-wire **26B** (FIGS. 24 and 25) being disposable within at least one portion of the stylet **824A**, such as useable in a catheter system, in accordance with an embodiment of the present disclosure.

[00123] The guide-wire **26B** is insertable, e.g., "weavable" or "threadable." into the stylet **824A** along at least a portion thereof, whereby a smooth transition is provided for enhancing stiffening and guiding of the catheter body **812**. The stylet **824A** is configured for inserting and translating through a lumen, such as the lumen **814A** or the lumen **814B**, for rotation, such as after insertion and translation, wherein a notched portion **860** of the stylet

distal portion, e.g., a cover or overhang portion **857**, is rotatable for optionally receiving the septum **813**, e.g., if the septum **813** includes a septum distal end **13e** extending from the septum **813** (FIGS. 13-15B), whereby further structural support is provided for enhancing stiffening and guiding of the catheter body **812**, and for receiving a guide-wire (FIGS. 24 and 25), such as by way of a distal end **53B** of the guide-wire **26B** through a first orifice **862** and a second orifice **864** of the first intra-catheter stiffener element **851A**, such as a single stylet **824A**.

[00124] Referring to FIG. 27, this schematic diagram illustrates, in a cutaway side view, a catheter apparatus **810** of a catheter insertion system, as shown in FIG. 26, comprising a catheter body **812** having two lumens **814A**, **814B** separated by a septum **813**, a first intra-catheter stiffener element **851A**, such as a single stylet **824A**, disposed through one lumen **814A**; and second intra-catheter stiffener element **51B**, such as a single guide-wire **26B**, disposed through the other lumen **814B**, a distal end **53B** of the guide-wire **26B** disposed within at least one portion of the stylet **824A**, such as useable in a catheter system, in accordance with an embodiment of the present disclosure.

[00125] The guide-wire **26B** is insertable, e.g., “weavable” or “threadable,” into the stylet **824A** along at least a portion thereof, whereby a smooth transition is provided for enhancing stiffening and guiding of the catheter body **812**. The stylet **824A** is configured for inserting and translating through a lumen, such as the lumen **814A** or the lumen **814B**, for rotation, such as after insertion and translation, wherein a notched portion **860** of the stylet distal portion, e.g., a cover or overhang portion **857**, is rotatable for optionally receiving the septum **813**, e.g., if the septum **813** includes a septum distal end **13e** extending from the septum **813** (FIGS. 13-15B), whereby further structural support is provided for enhancing stiffening and guiding of the catheter body **812**, and for receiving a guide-wire, such as by way of a distal end **53B** of the guide-wire **26B** through a first orifice **862** and a second orifice **864** of the first intra-catheter stiffener element **851A**, such as a single stylet **824A**.

[00126] The intra-catheter stiffener elements described herein may be configured in such a way for disposition within the lumens of any of the catheter systems described within the present disclosure. The distal end of the first intra-catheter stiffener element **851A** may be configured such that it is distal in relation to the distal end of septum **813** and a distal end of the second intra-catheter stiffener element **51B** may be configured such that it is also distal in relation to the distal end of septum **813**. The distal end of the first intra-catheter stiffener element and the distal end of the second intra-catheter stiffener element may be capable of

receiving and accommodating the other of the first intra-catheter stiffener element distal end and the second intra-catheter stiffener element distal end as described in various embodiments herein.

[00127] Referring to FIG. 28, this is a schematic diagram that illustrates a side view of a plurality of stylets **924C**, **924D**, such as two stylets, joined at a proximal end, such as by a joining member **970**, for use in a catheter system (not shown), in accordance with an embodiment of the present disclosure. Optionally, the stylet tip is adapted to accept a guide-wire tip therein for enhancing stiffening. The stylets may be joined together in releasable fashion such that they can be introduced together as joined, separated after introduction through the catheter, or separated first, then introduced. The joining member **970** therefore can be permanently joined, for example, via adhesive or welding, or may be removable, such as a tape member or elastic member. The joining member **970** in one embodiment may be a removable joining member that snaps onto the proximal ends of the stylets, such as a form fitting plastic member.

[00128] FIG. 29 is a schematic diagram illustrating a partially cutaway side view of a stylet **924C** of a plurality of stylets **924C**, **924D** for a hemodialysis catheter insertion system (not shown), each stylet **924C** of a plurality of stylets **924C**, **924D** having a lumen **914** extending along its length sized to accommodate a guide-wire (not shown) and a hemi-toroidal tip **926**, rather than a tapered tip, whereby trauma to the blood vessel is minimized, in accordance with an embodiment of the present disclosure. In another embodiment only one of the plurality of stylets has a hemi-toroidal tip, and one or more of the other stylets has a tapered tip.

[00129] The intra-catheter stiffener elements described herein may be configured in such a way for disposition within the lumens of any of the catheter systems described within the present disclosure. The distal end of the first stylet **924C** may be configured such that it is distal in relation to the distal end of the catheter apparatus (not shown) and a distal end of the second stylet **924D** may be configured such that it is also distal in relation to the distal end of the catheter apparatus (not shown). The distal end of the first intra-catheter stiffener element and the distal end of the second intra-catheter stiffener element may be capable of receiving and accommodating the other of the first intra-catheter stiffener element distal end and the second intra-catheter stiffener element distal end as described in various embodiments herein.

[00130] Referring to FIG. 30, this schematic diagram illustrates, in a cut-away perspective view, an expandable catheter insertion system **1010**, having a stylet in an unexpanded condition, in accordance with an embodiment of the present disclosure. The catheter system **1010** includes: a catheter body **1012** including: two internal lumens **1014A** and **1014B**; a septum **1013**, the septum **1013** separating the lumens **1014A**, **1014B**; a stylet **1018** having a stylet tip **1020**; and a guide-wire **26B** (not shown) having a guide-wire tip **1026** (not shown). The stylet tip **1020** includes at least one expansion feature **1022**, such as an expansion slit, and at least one opening for accommodating a guide-wire **26** (not shown), such as an entry opening **1024** and an exit opening **1028**, e.g., by “threading” or “weaving” the guide-wire tip **1026** (not shown) through the lumen **1014A**, along the stylet **1018**, through the entry opening **1024** and through the exit opening **1028**. The guide-wire **26** (not shown) facilitates further stiffening and guiding of the catheter body **1012** through a blood vessel. By example only, the stylet tip **1020** includes at least one configuration of a tapered configuration and elliptical cross-section and a frusto-conical configuration.

[00131] Referring to FIG. 31, this schematic diagram illustrates, in an exploded cut-away perspective view, an expandable (e.g., deformable and reformable) catheter insertion system **1010**, having a stylet in an unexpanded condition, in accordance with an embodiment of the present disclosure. The catheter system **1010** includes: a catheter body **1012** comprising: two internal lumens **1014A** and **1014B**; a septum **1013**, the septum **1013** separating the lumens **1014A**, **1014B**; a stylet **1018** having a stylet tip **1020**; and a guide-wire **26** (not shown) having a guide-wire tip **1026** (not shown). The stylet tip **1020** includes least one expansion feature **1022**, such as an expansion slit, and at least one opening for accommodating a guide-wire **26** (not shown), such as an entry opening **1024** and an exit opening **1028**, e.g., by “weaving” or “threading” the guide-wire tip **1026** (not shown) through the lumen **1014A**, along the stylet **1018**, through the entry opening **1024** and through the exit opening **1028**. The guide-wire **26** (not shown) facilitates further stiffening and guiding of the catheter body **1012** through a blood vessel. By example only, the stylet tip **1020** includes at least one configuration of a tapered configuration and elliptical cross-section and a frusto-conical configuration.

[00132] Referring to FIG. 32, this schematic diagram illustrates, in a cut-away top view, an expandable catheter insertion system **1010**, having a stylet in an unexpanded condition, in accordance with an embodiment of the present disclosure. The catheter system **1010** includes: a catheter body **1012** including: two internal lumens **1014A** and **1014B**; a septum **1013**, the

septum **1013** separating the lumens **1014A**, **1014B**; a stylet **1018** having a stylet tip **1020**; and a guide-wire **26** (not shown) having a guide-wire tip **1026** (not shown). The stylet tip **1020** includes at least one expansion feature **1022**, such as an expansion slit, and at least one opening for accommodating a guide-wire **26** (not shown), such as an entry opening **1024** and an exit opening **1028**, e.g., by “weaving” or “threading” the guide-wire tip **1026** (not shown) through the lumen **1014A**, along the stylet **1018**, through the entry opening **1024** and through the exit opening **1028**. The guide-wire **26** (not shown) facilitates further stiffening and guiding of the catheter body **1012** through a blood vessel. By example only, the stylet tip **1020** includes at least one configuration of a tapered configuration and elliptical cross-section and a frusto-conical configuration.

[00133] Referring to FIG. 33, this schematic diagram illustrates, in a cut-away top view, an expandable catheter insertion system **1010**, having a stylet in an expanded condition and a guide-wire disposed therethrough, the guide-wire facilitating expansion of the stylet, in accordance with an embodiment of the present disclosure. The catheter system **1010** includes: a catheter body **1012** including: two internal lumens **1014A** and **1014B**; a septum **1013**, the septum **1013** separating the lumens **1014A**, **1014B**; a stylet **1018** having a stylet tip **1020**; and a guide-wire **26** having a guide-wire tip **1026**. The stylet tip **1020** includes least one expansion feature **1022**, such as an expansion slit, and at least one opening for accommodating a guide-wire **26**, such as an entry opening **1024** and an exit opening **1028**, e.g., by “weaving” or “threading” the guide-wire tip **1026** through the lumen **1014A**, along the stylet **1018**, through the entry opening **1024** and through the exit opening **1028**. The guide-wire **26** facilitates further stiffening and guiding of the catheter body **1012** through a blood vessel. By example only, the stylet tip **1020** includes at least one configuration of a tapered configuration and elliptical cross-section and a frusto-conical configuration.

[00134] Referring to FIG. 34, this schematic diagram illustrates, in a cut-away side view, an expandable catheter insertion system **1010**, having a stylet in an unexpanded condition, wherein the stylet includes at least one slit for facilitating expansion, in accordance with an embodiment of the present disclosure. The catheter system **1010** includes: a catheter body **1012** including: two internal lumens **1014A** and **1014B**; a septum **1013**, the septum **1013** separating the lumens **1014A**, **1014B**; a stylet **1018** having a stylet tip **1020**; and a guide-wire **26** (not shown) having a guide-wire tip **1026** (not shown). The stylet tip **1020** includes least one expansion feature **1022**, such as an expansion slit, and at least one opening for

accommodating a guide-wire **26** (not shown), such as an entry opening **1024** and an exit opening **1028**, e.g., by “weaving” or “threading” the guide-wire tip **1026** (not shown) through the lumen **1014A**, along the stylet **1018**, through the entry opening **1024** and through the exit opening **1028**. The guide-wire **26** (not shown) facilitates further stiffening and guiding of the catheter body **1012** through a blood vessel. By example only, the stylet tip **1020** includes at least one configuration of a tapered configuration and elliptical cross-section and a frusto-conical configuration.

[00135] Referring to FIG. 35, this schematic diagram illustrates, in a cut-away side view, an expandable catheter insertion system **1010**, having a stylet **1018** in an expanded condition, in accordance with an embodiment of the present disclosure. The catheter system **1010** includes: a catheter body **1012** including: two internal lumens **1014A** and **1014B**; a septum **1013**, the septum **1013** separating the lumens **1014A**, **1014B**; a stylet **1018** having a stylet tip **1020**; and a guide-wire **26** (not shown) having a guide-wire tip **1026** (not shown). The stylet tip **1020** includes least one expansion feature **1022**, such as an expansion slit, and at least one opening for accommodating a guide-wire **26** (not shown), such as an entry opening **1024** and an exit opening **1028**, e.g., by “weaving” or “threading” the guide-wire tip **1026** (not shown) through the lumen **1014A**, along the stylet **1018**, through the entry opening **1024** and through the exit opening **1028**. The guide-wire **26** (not shown) facilitates further stiffening and guiding of the catheter body **1012** through a blood vessel. By example only, the stylet tip **1020** includes at least one configuration of a tapered configuration and elliptical cross-section and a frusto-conical configuration. The stylet tip **1020** includes of a portion **1030** that is deflectable for accommodating the guide-wire **26** (not shown).

[00136] Referring to FIG. 36, this schematic diagram illustrates, in a cut-away side view, a catheter insertion system **1010**, having a stylet **1018** in an expanded condition and a guide-wire **26** disposed therethrough, the guide-wire **26** facilitating expansion of the stylet **1018**, in accordance with an embodiment of the present disclosure. The catheter system **1010** includes: a catheter body **1012** including: two internal lumens **1014A** and **1014B**; a septum **1013**, the septum **1013** separating the lumens **1014A**, **1014B**; a stylet **1018** having a stylet tip **1020**; and a guide-wire **26** having a guide-wire tip **1026**. The stylet tip **1020** includes least one expansion feature **1022**, such as an expansion slit, and at least one opening for accommodating a guide-wire **26**, such as an entry opening **1024** and an exit opening **1028**, e.g., by “weaving” or “threading” the guide-wire tip **1026** through the lumen **1014A**, along the stylet **1018**, through

the entry opening **1024** and through the exit opening **1028**. The guide-wire **26** facilitates further stiffening and guiding of the catheter body **1012** through a blood vessel. By example only, the stylet tip **1020** includes at least one configuration of a tapered configuration and elliptical cross-section and a frusto-conical configuration. The stylet tip **1020** includes a portion **1030** of is deflectable for accommodating the guide-wire **26**.

[00137] Referring to FIG. 37, this a schematic diagram illustrates, in a cut-away perspective view, a catheter insertion system **1010**, having a stylet **1018** in an expanded condition and a guide-wire **26B** disposed therethrough, the guide-wire **26B** facilitating expansion of the stylet **1018**, in accordance with an embodiment of the present disclosure. The catheter system **1010** includes: a catheter body **1012** comprising: two internal lumens **1014A** and **1014B**; a septum **1013**, the septum **1013** separating the lumens **1014A**, **1014B**; a stylet **1018** having a stylet tip **1020**; and a guide-wire **26B** having a guide-wire tip **1026**. The stylet tip **1020** includes least one expansion feature **1022**, such as an expansion slit, and at least one opening for accommodating a guide-wire **26**, such as an entry opening **1024** and an exit opening **1028**, e.g., by “weaving” or “threading” the guide-wire tip **1026** through the lumen **1014A**, along the stylet **1018**, through the entry opening **1024** and through the exit opening **1028**. The guide-wire **26** facilitates further stiffening and guiding of the catheter body **1012** through a blood vessel. By example only, the stylet tip **1020** includes at least one configuration of a tapered configuration and elliptical cross-section and a frusto-conical configuration. The stylet tip **1020** includes a portion **1030** of is deflectable for accommodating the guide-wire **26**.

[00138] The intra-catheter stiffener elements described herein may be configured in such a way for disposition within the lumens of any of the catheter systems described within the present disclosure. The distal end of the first intra-catheter stiffener element **1018** may be configured such that it is distal in relation to the distal end of septum **1013** and a distal end of the second intra-catheter stiffener element **26B** may be configured such that it is also distal in relation to the distal end of the distal end of septum **1013**. The distal end of the first intra-catheter stiffener element and the distal end of the second intra-catheter stiffener element may be capable of receiving and accommodating the other of the first intra-catheter stiffener element distal end and the second intra-catheter stiffener element distal end as described in various embodiments herein.

[00139] Information as herein shown and described in detail is fully capable of attaining the above-described object of the present disclosure, the presently preferred embodiment of the

present disclosure, and is, thus, representative of the subject matter which is broadly contemplated by the present disclosure. The scope of the present disclosure fully encompasses other embodiments which may become obvious to those skilled in the art, and is to be limited, accordingly, by nothing other than the appended claims, wherein any reference to an element being made in the singular is not intended to mean "one and only one" unless explicitly so stated, but rather "one or more." All structural and functional equivalents to the elements of the above-described preferred embodiment and additional embodiments as regarded by those of ordinary skill in the art are hereby expressly incorporated by reference and are intended to be encompassed by the present claims. Features and/or steps described with respect to one embodiment may be incorporated into other embodiments.

[00140] Moreover, no requirement exists for a system or method to address each and every problem sought to be resolved by the present disclosure, for such to be encompassed by the present claims. Furthermore, no element, component, or method step in the present disclosure is intended to be dedicated to the public regardless of whether the element, component, or method step is explicitly recited in the claims. However, that various changes and modifications in form, material, work-piece, and fabrication material detail may be made, without departing from the spirit and scope of the present disclosure, as set forth in the appended claims, as may be apparent to those of ordinary skill in the art, are also encompassed by the present disclosure.

CLAIMS

What is claimed:

1. A catheter apparatus, comprising:
 - a catheter body comprising a first lumen capable of fluid communication via a first distal opening and a second lumen capable of fluid communication via a second distal opening;
 - a first intra-catheter stiffener element configured for disposition through the first lumen such that a distal end thereof is distal in relation to the first distal opening, the first intra-catheter stiffener element comprising at least one of a guide-wire and a stylet; and
 - a second intra-catheter stiffener element configured for disposition through the second lumen such that a distal end thereof is distal in relation to the second distal opening, the second intra-catheter stiffener element comprising a guide-wire,one of the first intra-catheter stiffener element distal end and the second intra-catheter stiffener element distal end capable of receiving and accommodating the other of the first intra-catheter stiffener element distal end and the second intra-catheter stiffener element distal end.
2. The apparatus of claim 1, wherein one of the first intra-catheter stiffener element and the second intra-catheter stiffener element comprises at least one of an eye portion and a looped portion disposed at the distal end thereof capable of receiving and facilitating disposition therethrough of the distal end of the other of the first intra-catheter stiffener element and the second intra-catheter stiffener element.
3. The apparatus of claim 1, wherein the catheter body comprises a septum for separating the first lumen and the second lumen from one another, the septum having a distal end extending beyond at least one of the first distal opening and the second distal opening for at least minimizing backflow into at least one of the first lumen and the second lumen.
4. The apparatus of claim 3, wherein one of the first intra-catheter stiffener element and the second intra-catheter stiffener element comprises a cover portion at the distal end thereof, the cover portion capable of deployment and retraction in relation to one of the first

lumen and the second lumen, and the cover portion cooperatively engageable with the septum distal end for at least minimizing backflow into the one of the first lumen and the second lumen.

5. The apparatus of claim 4, wherein the cover portion is deployable and retractable via at least one technique of a rotation and a translation in relation to a longitudinal axis thereof.

6. The apparatus of claim 1, wherein the stylet comprises at least one of a monolithic configuration and a tapered configuration.

7. The apparatus of claim 1, wherein the first intra-catheter stiffener element comprises a first length, and wherein the second intra-catheter stiffener element comprises a second length, the second length less than the first length.

8. The apparatus of claim 1, wherein the first intra-catheter stiffener element includes a first coupler at a proximal end thereof, and wherein the second intra-catheter stiffener element includes a second coupler at a proximal end thereof.

9. The apparatus of claim 8, wherein the first coupler of the first intra-catheter stiffener element mates with the first coupler at a first proximal opening of the catheter body, and wherein the second coupler of the second intra-catheter stiffener element mates with the second coupler at a second proximal opening of the catheter body.

10. The apparatus of claim 9, wherein the distal end of the first intra-catheter stiffener element is distal in relation to the distal end of the second intra-catheter stiffener element when the first coupler and second coupler are coupled to the catheter body.

11. The apparatus of claim 1, wherein the first intra-catheter stiffener element comprises an exterior cross-sectional shape complementing an interior cross-sectional shape of the first lumen, and wherein the second intra-catheter stiffener element comprises an exterior cross-sectional shape complementing an interior cross-sectional shape of the second lumen.

12. A method of fabricating a catheter apparatus, comprising:
obtaining a catheter comprising a first lumen capable of fluid communication via a first distal opening and a second lumen capable of fluid communication via a second distal opening;

obtaining a first intra-catheter stiffener element configured for disposition through the first lumen such that a distal end thereof is distal in relation to the first distal opening; and

obtaining a second intra-catheter stiffener element configured for disposition through the second lumen such that a distal end thereof is distal in relation to the second distal opening,

wherein one of the first intra-catheter stiffener element distal end and the second intra-catheter stiffener element distal end is capable of receiving and accommodating the other of the first intra-catheter stiffener element distal end and the second intra-catheter stiffener element distal end.

13. The method of claim 12, wherein one of the first intra-catheter stiffener element and the second intra-catheter stiffener element are provided with at least one of an eye portion and a looped portion disposed at the distal end thereof capable of receiving and facilitating disposition therethrough of the distal end of the other of the first intra-catheter stiffener element and the second intra-catheter stiffener element.

14. The method of claim 12, wherein the catheter body is provided with a septum for separating the first lumen and the second lumen from one another, the septum extending a distal end thereof beyond at least one of the first distal opening and the second distal opening.

15. The method of claim 14, wherein one of the first intra-catheter stiffener element and the second intra-catheter stiffener element is provided with a cover portion at the distal end thereof, the cover portion capable of deployment and retraction in relation to one of the first lumen and the second lumen, and the cover portion cooperatively engageable with the septum distal end for minimizing backflow into the one of the first lumen and the second lumen.

16. The method of claim 15, wherein the cover portion is deployable and retractable via rotation and a translation in relation to a longitudinal axis thereof.

17. A method of inserting a catheter into a blood vessel by way of a catheter apparatus, comprising:

obtaining the catheter apparatus, the catheter apparatus comprising:

a catheter comprising a first lumen capable of fluid communication via a first distal opening and a second lumen capable of fluid communication via a second distal opening;

a first intra-catheter stiffener element configured for disposition through the first lumen such that a distal end thereof is distal in relation to the first distal opening; and

a second intra-catheter stiffener element configured for disposition through the second lumen such that a distal end thereof is distal in relation to the second distal opening,

wherein one of the first intra-catheter stiffener element distal end and the second intra-catheter stiffener element distal end is capable of receiving and accommodating the other of the first intra-catheter stiffener element distal end and the second intra-catheter stiffener element distal end;

creating a first entry into a patient;

deforming a portion of the first intra-catheter stiffener element;

disposing the second intra-catheter stiffener element in at least one lumen of the first intra-catheter stiffener element;

disposing a distal end of the catheter through the first entry

creating a second entry in a patient, tissue, or the blood vessel;

disposing the distal end of the catheter through the second entry; and

reforming the stylet tip by way of withdrawing the first intra-catheter stiffener element from the at least one lumen, thereby minimizing trauma to the blood vessel.

18. A catheter apparatus, comprising:

a catheter body; and

a plurality of stylets joined at a proximal end and disposable within the catheter body, each stylet of the plurality of stylets comprising:

a lumen capable of receiving an elongated element; and

an expandable stylet tip designed to deformably expand upon introduction of the elongated element, and reformably contract upon removal of the elongated element.

19. The apparatus according to claim 18, wherein each stylet of the plurality of stylets comprises a hemi-toroidal tip.

20. A method of inserting a catheter into a blood vessel by way of a catheter apparatus, comprising:

providing the catheter apparatus, comprising:

a catheter body; and

a plurality of stylets joined at a proximal end and disposable within the catheter body, the plurality of stylets each comprising a lumen and an expandable stylet tip, wherein each lumen of the plurality of stylets is capable of receiving at least one elongated element and facilitating fluid communication;

creating a first incision into a patient;

deforming the stylet tip by way of receiving and disposing the at least one elongated element in at least one lumen of the plurality of stylets;

disposing a distal end of the catheter body through the first incision;

creating a second incision in a patient, tissue, or blood vessel;

disposing the distal end of the catheter body through the second incision; and

reforming the stylet tip by way of withdrawing the at least one elongated element from the at least one lumen, thereby minimizing trauma to the blood vessel.

21. A catheter apparatus, comprising:

a catheter body having a first lumen and a second lumen;

a stylet configured for removable disposition in the first lumen, the stylet comprising an expandable stylet tip having a deflectable portion, the deflectable portion comprising an entry opening and an exit opening; and

a guide-wire configured for removable disposition in the second lumen and for removable disposition through the expandable stylet tip, the guide-wire comprising a guide-wire tip.

22. The apparatus of claim 21, wherein the deflectable portion comprises an expansion slit, the stylet tip configured to accommodate a guide-wire, the guide-wire configured to thread through the other lumen, along the stylet, through the entry opening, and through the exit opening, whereby the guide-wire facilitates further stiffening and guiding of the catheter body through a blood vessel.

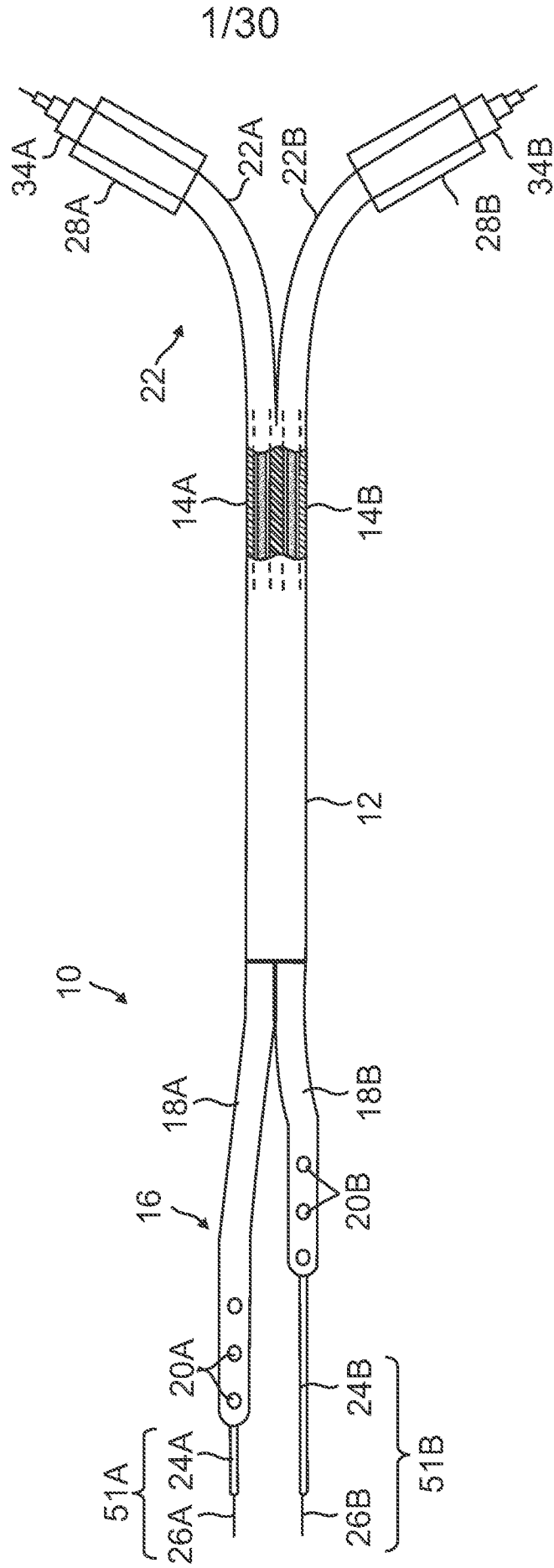

FIG. 1

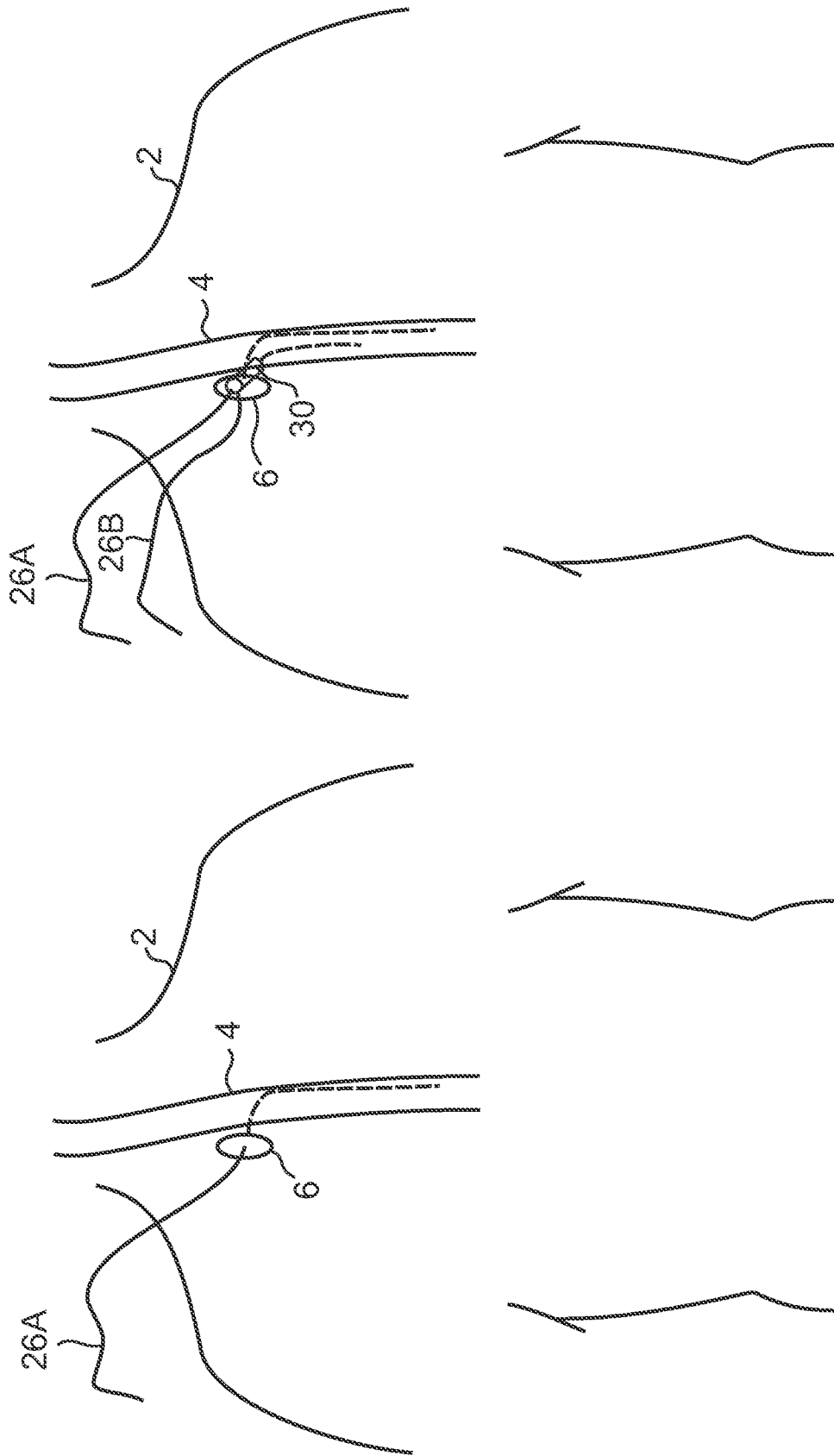

FIG. 2

FIG. 3

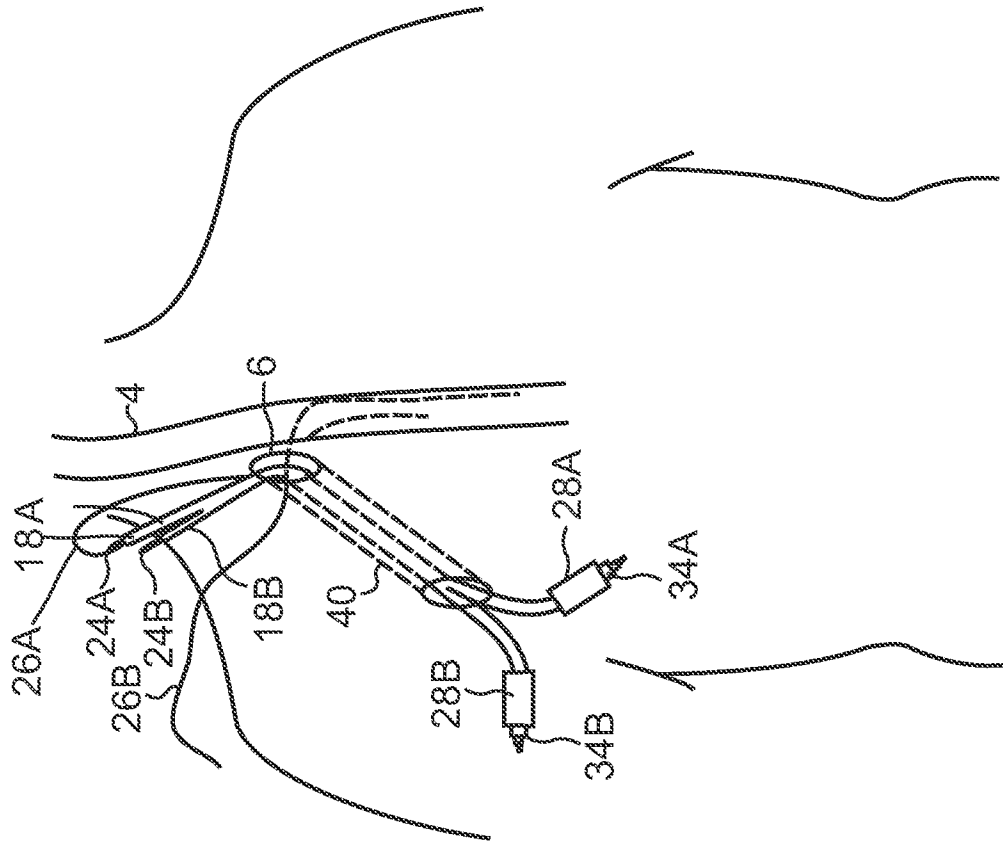

FIG. 5

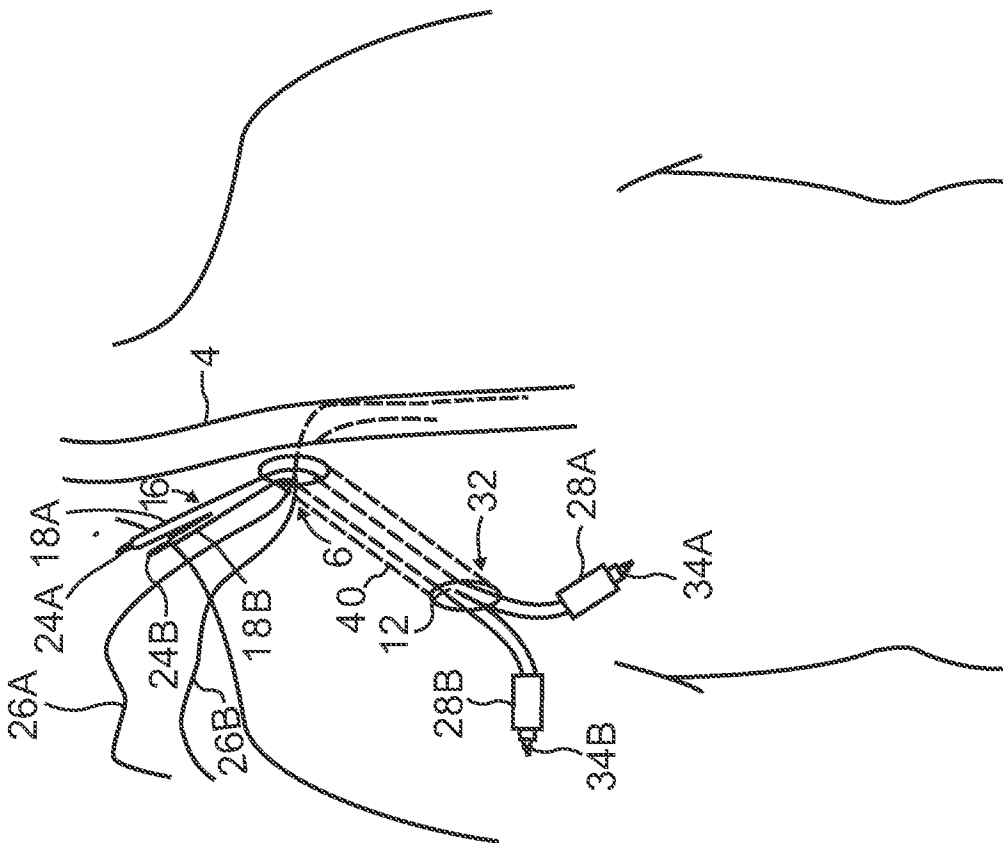

FIG. 4

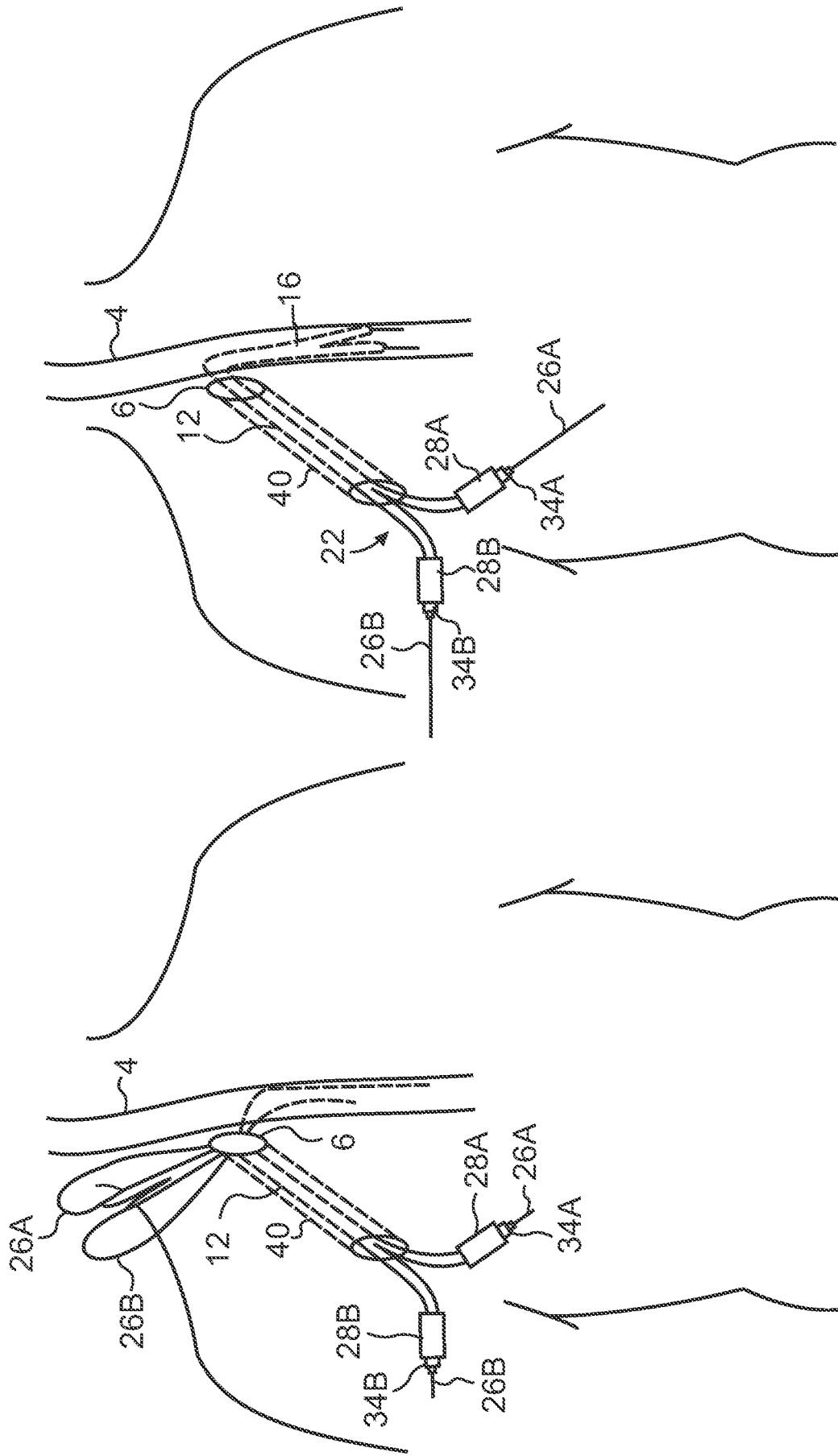

FIG. 7

FIG. 6

5/30

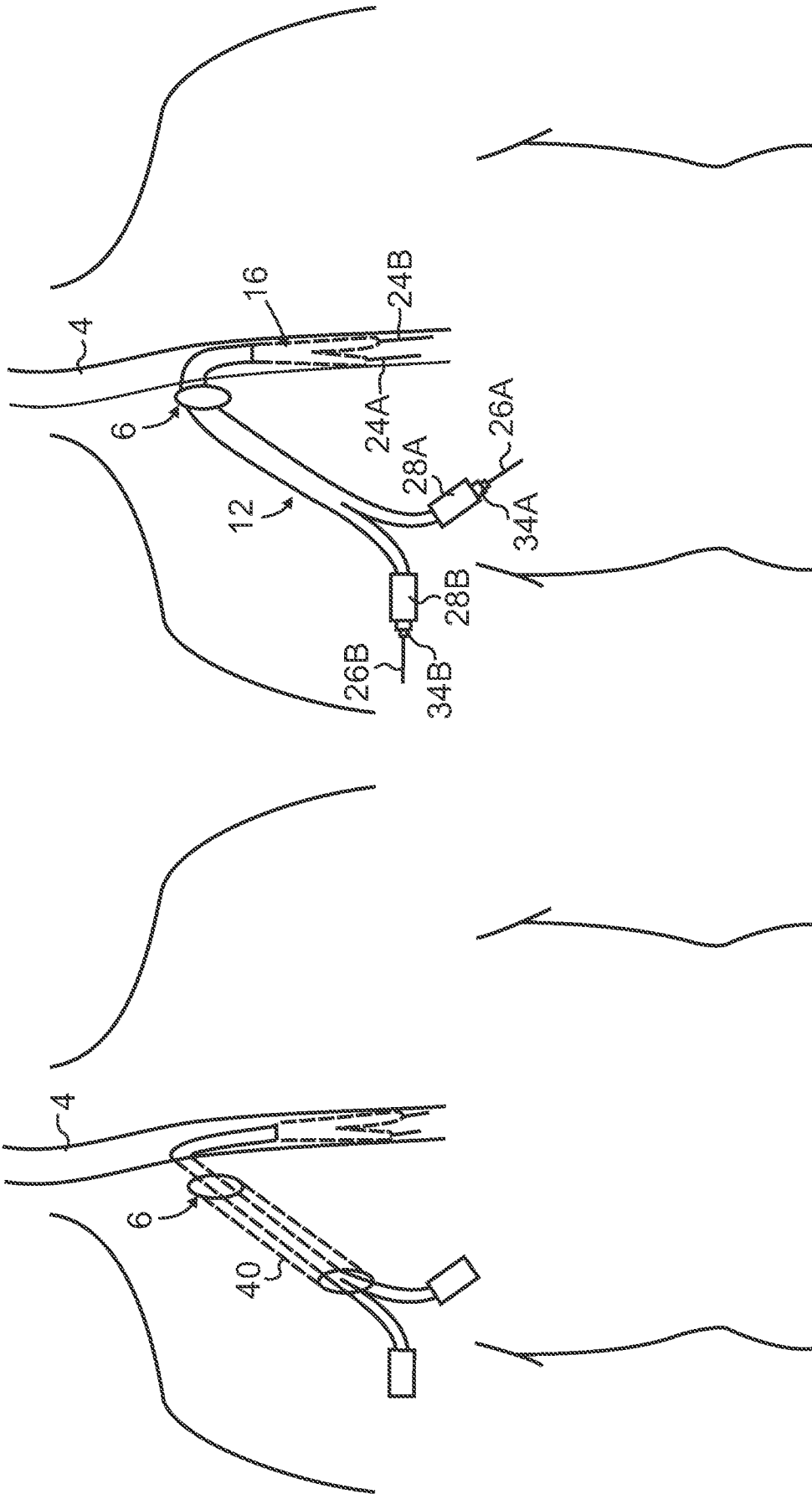

FIG. 9

FIG. 8

6/30

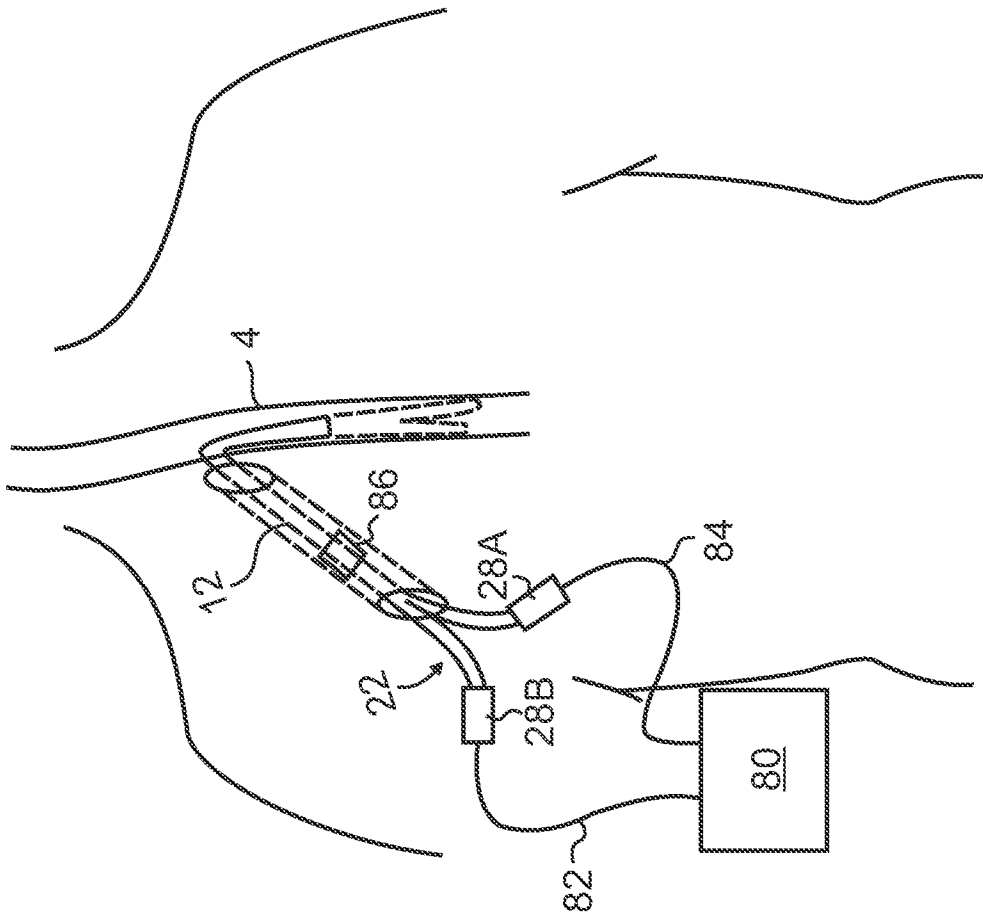

FIG. 10

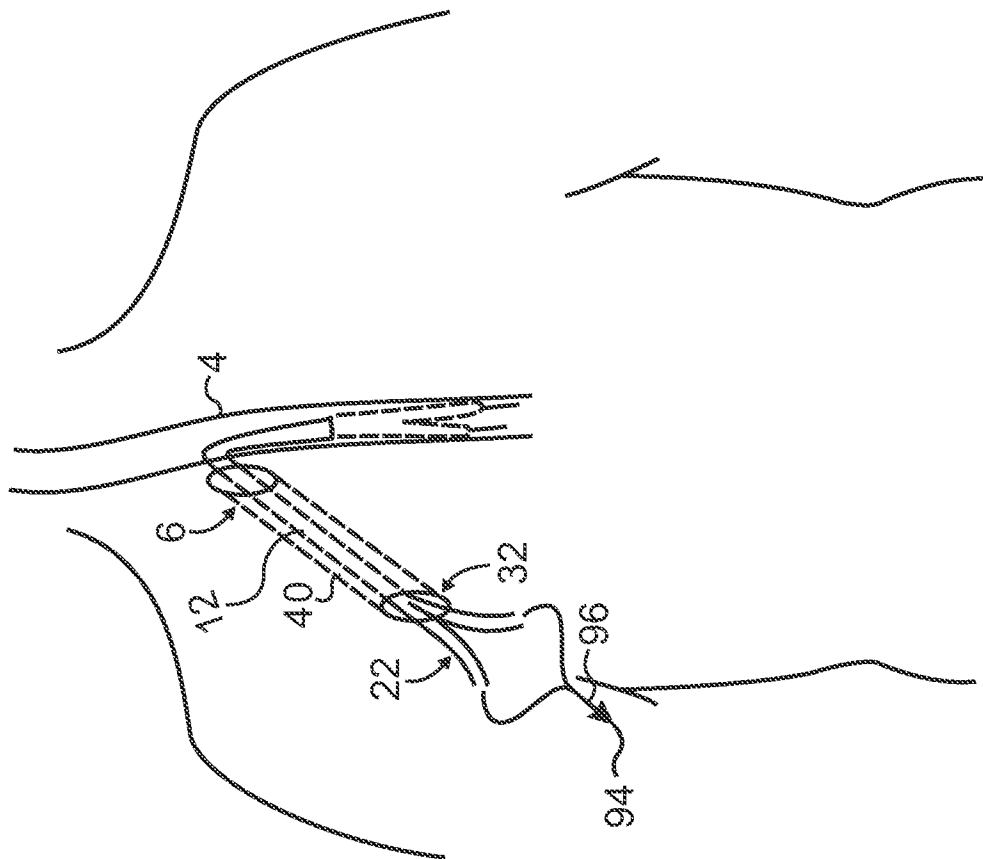

FIG. 11

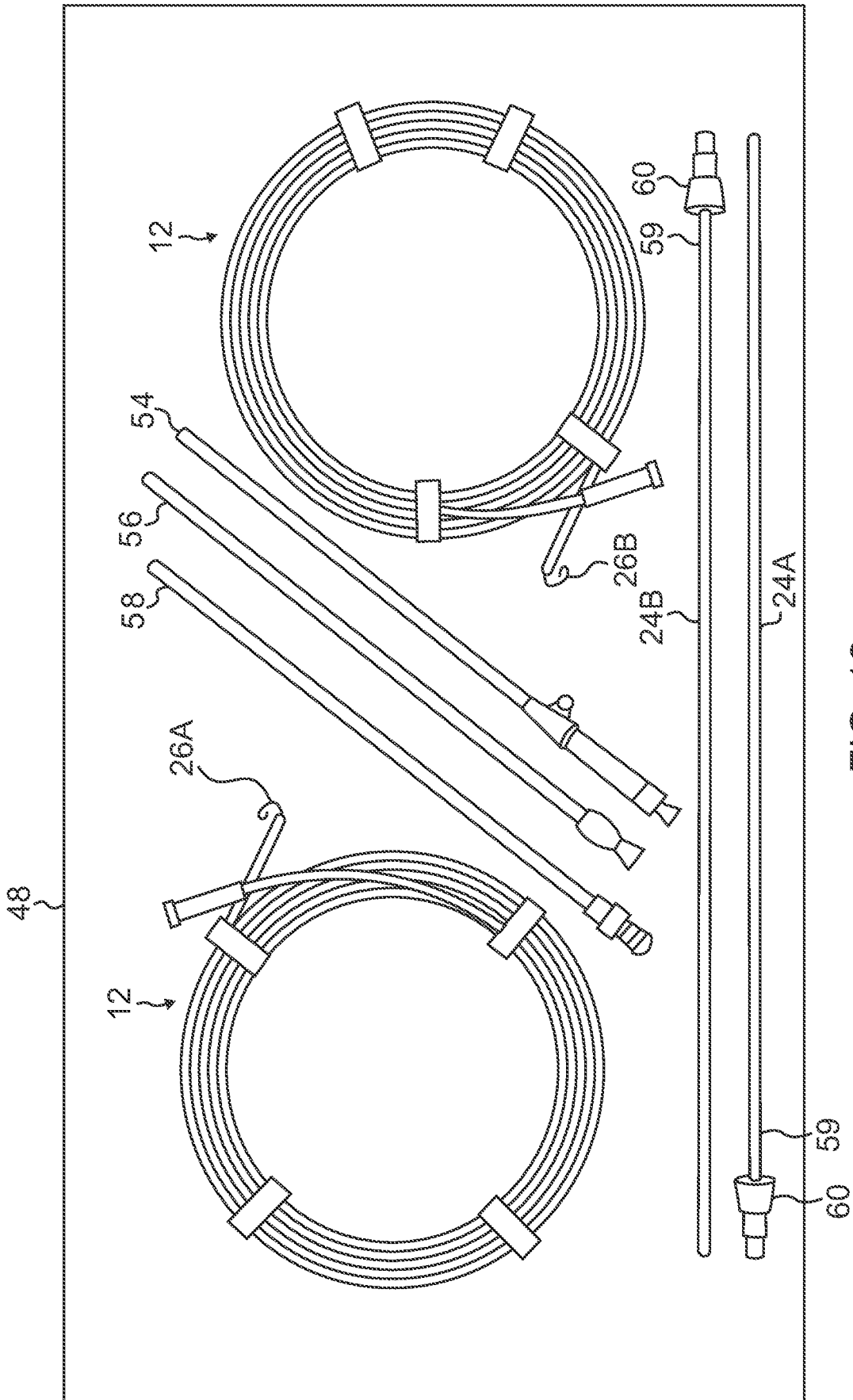

FIG. 12

8/30

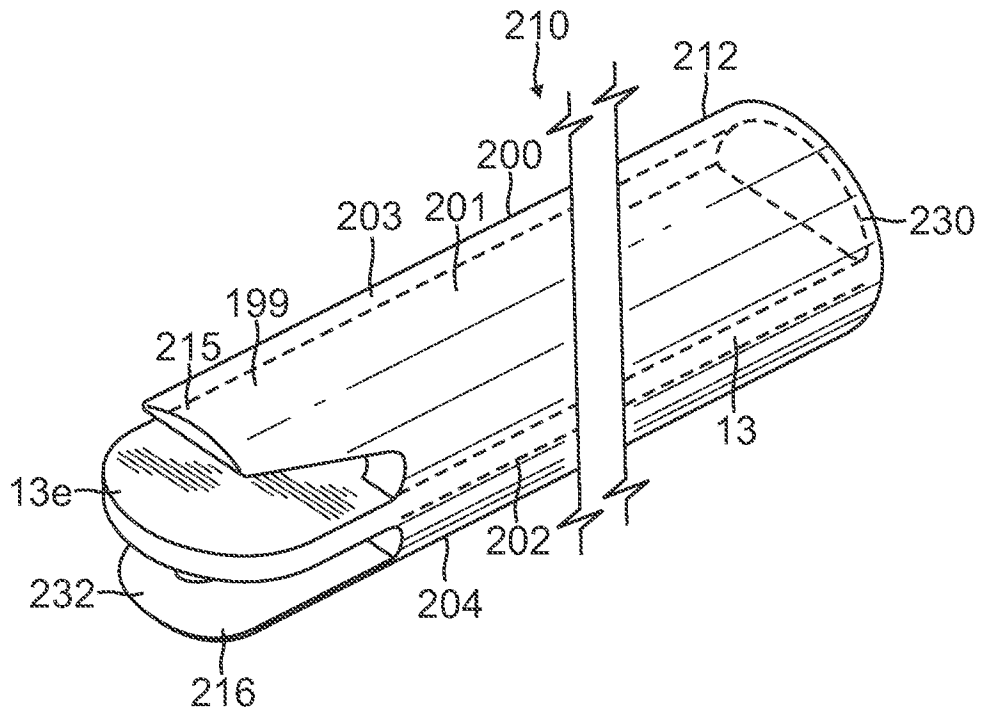

FIG. 13

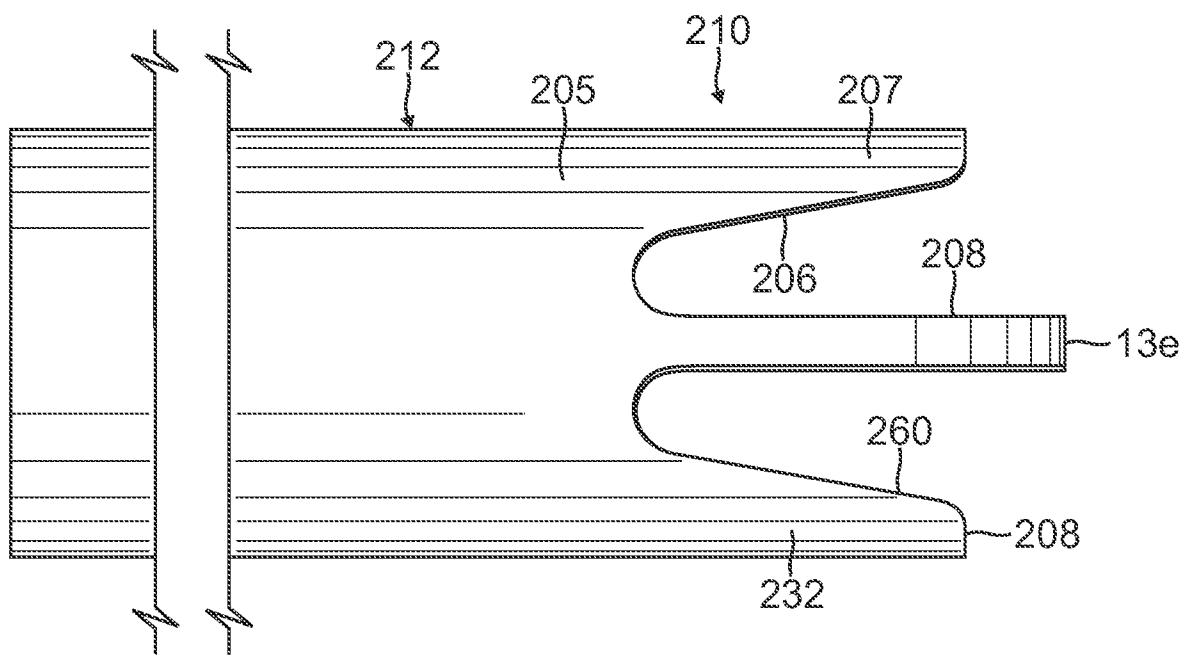

FIG. 14

9/30

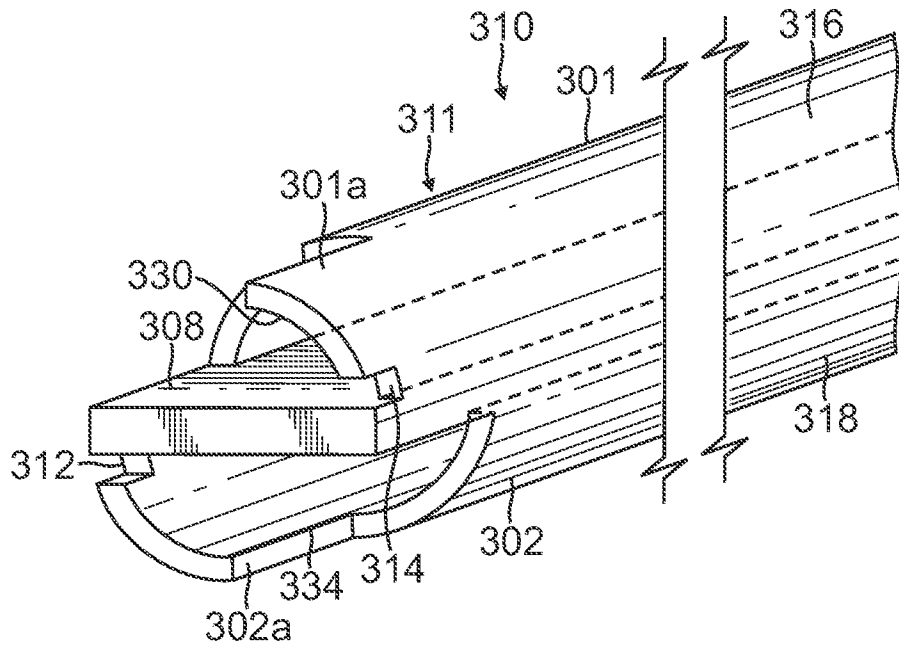

FIG. 15

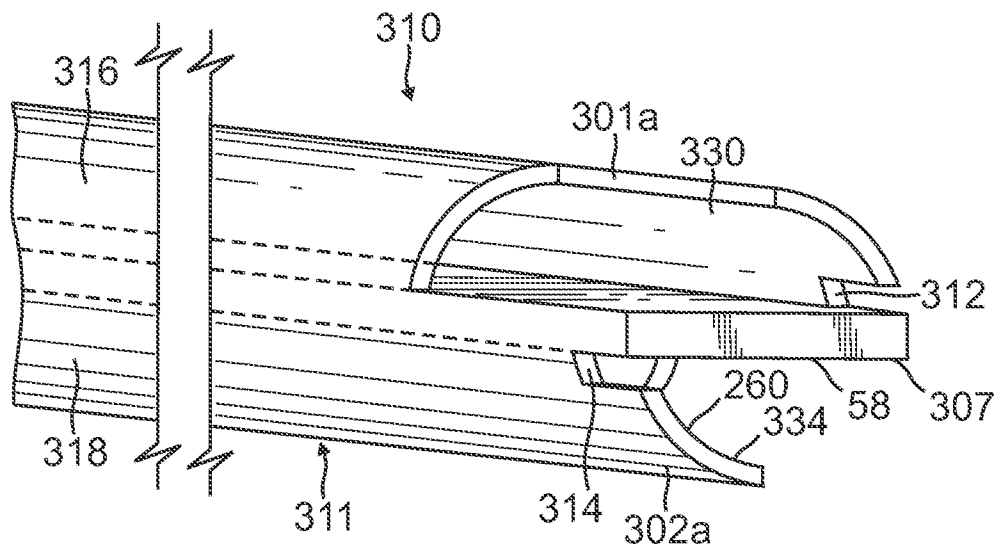

FIG. 16

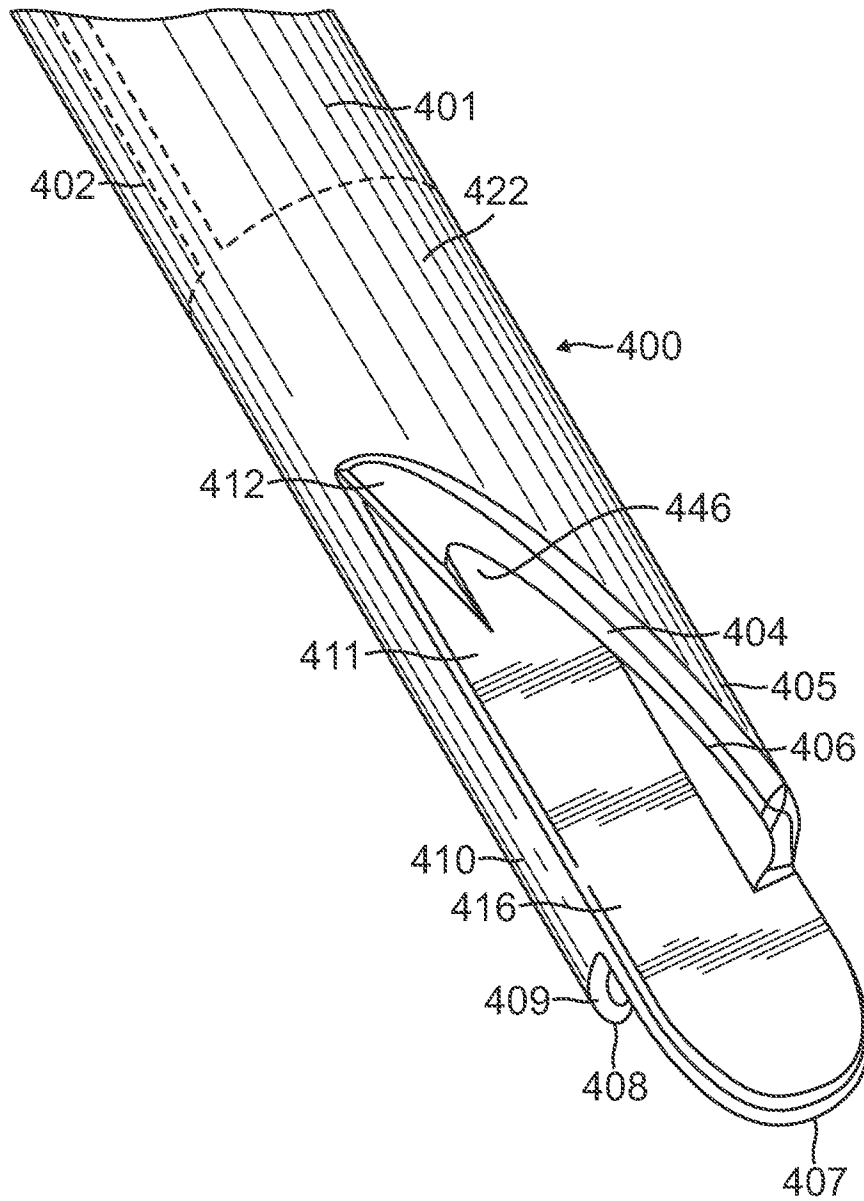

FIG. 17

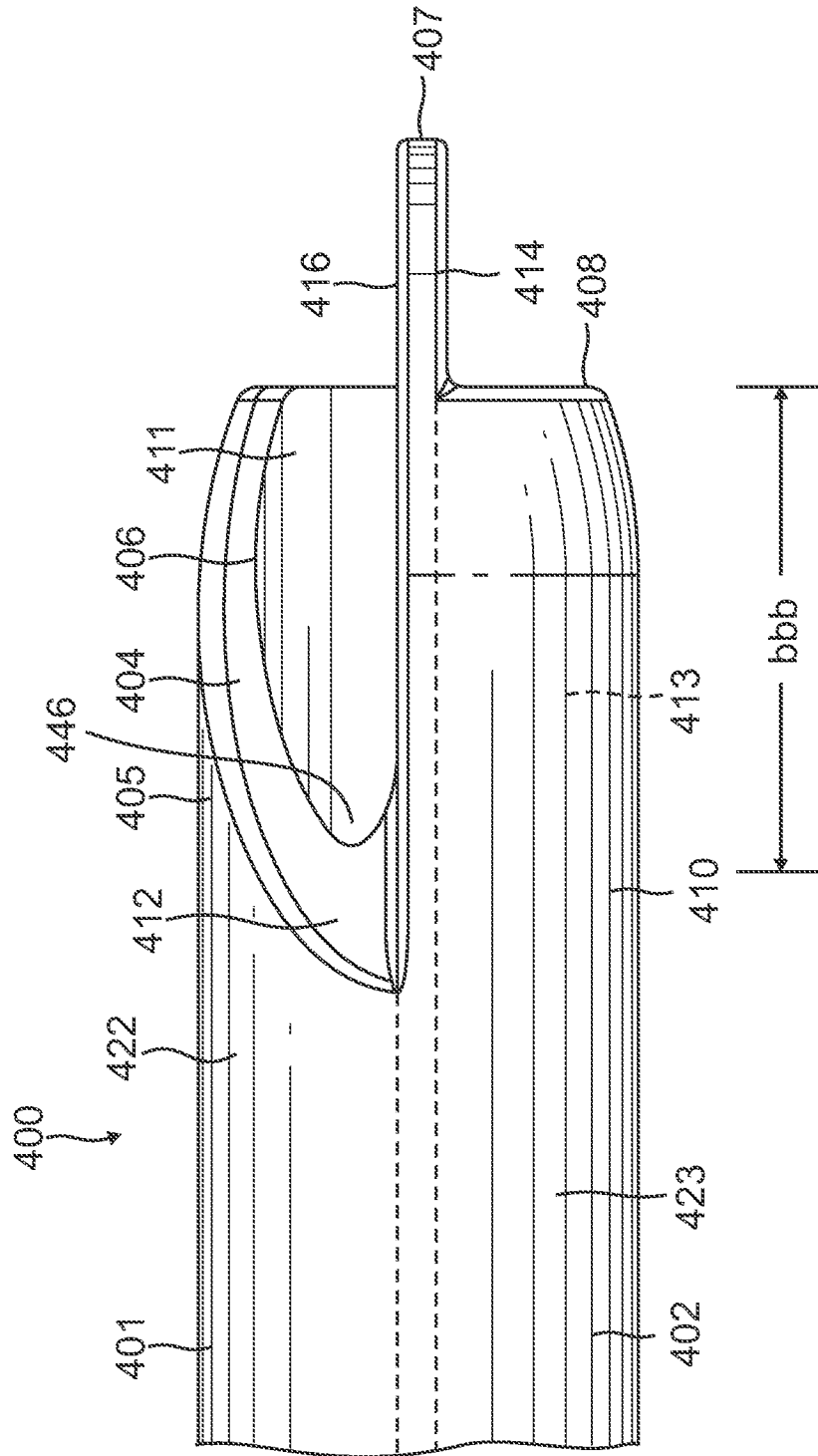

FIG. 18

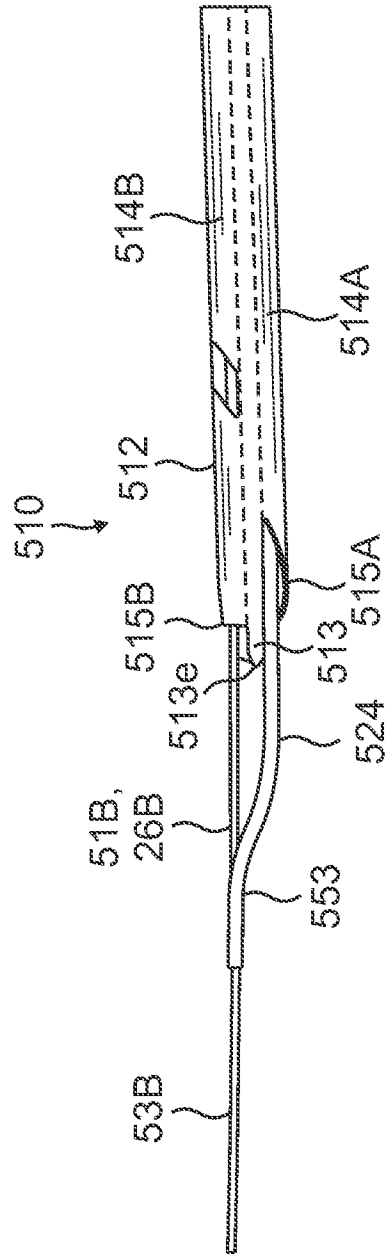

FIG. 19

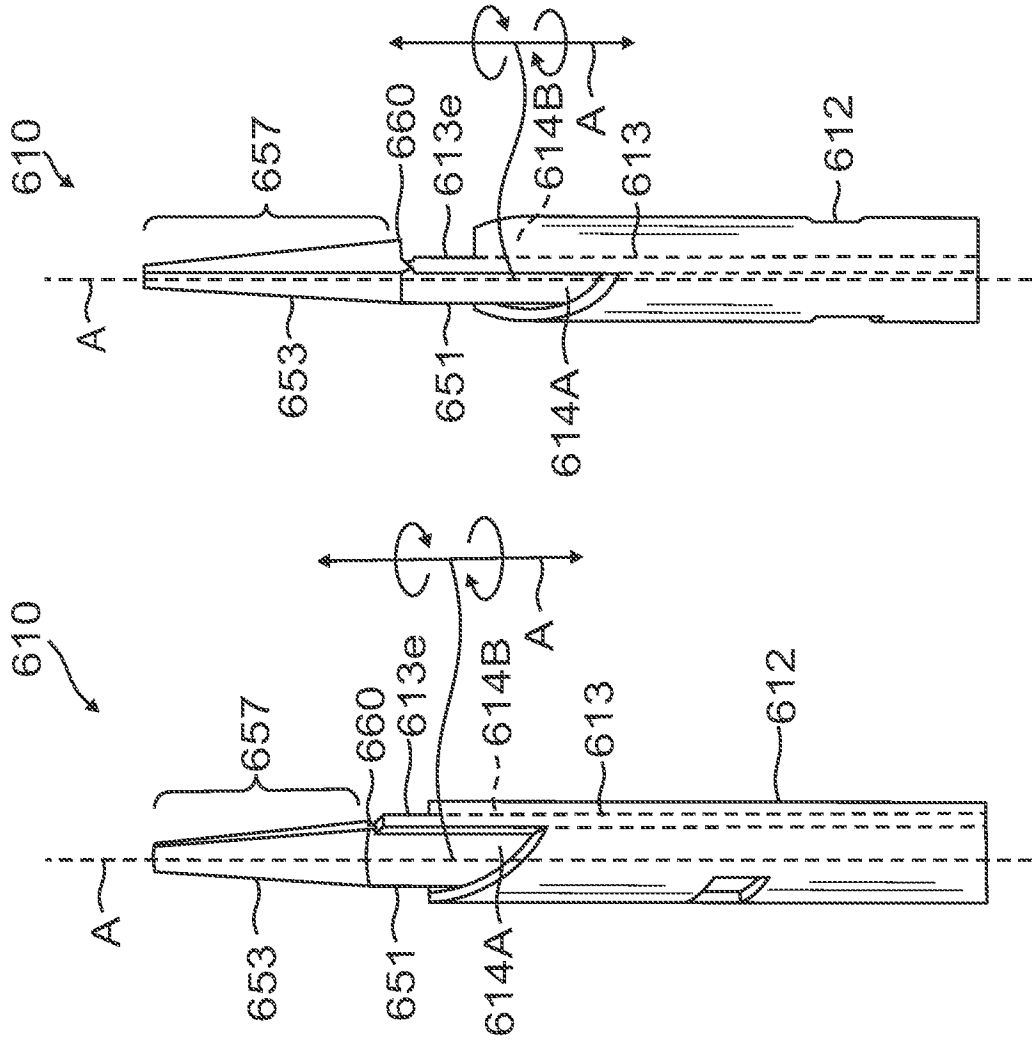

FIG. 20B

FIG. 20A

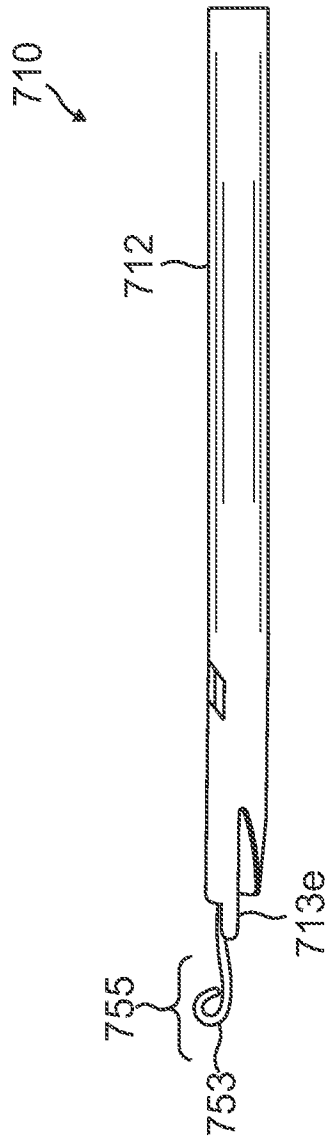

FIG. 21A

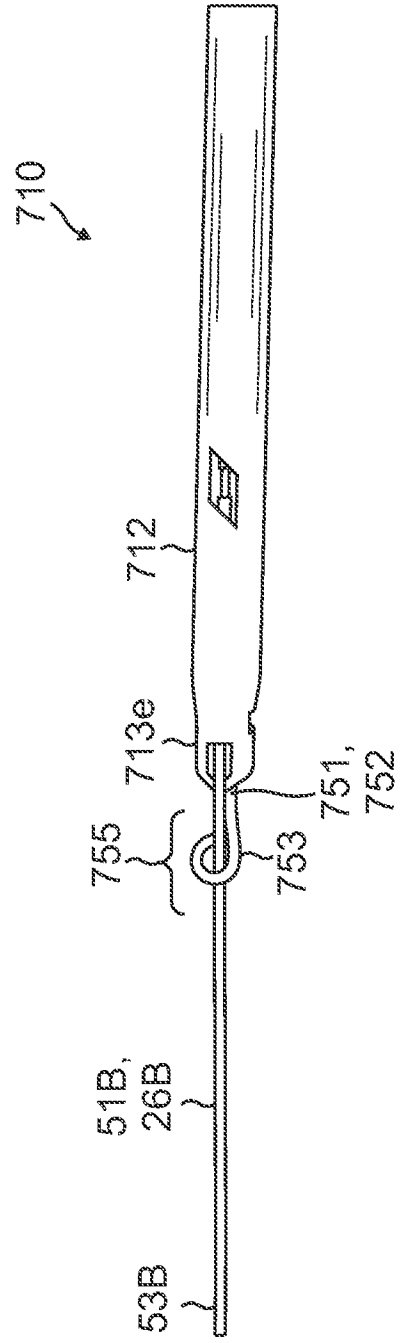

FIG. 21B

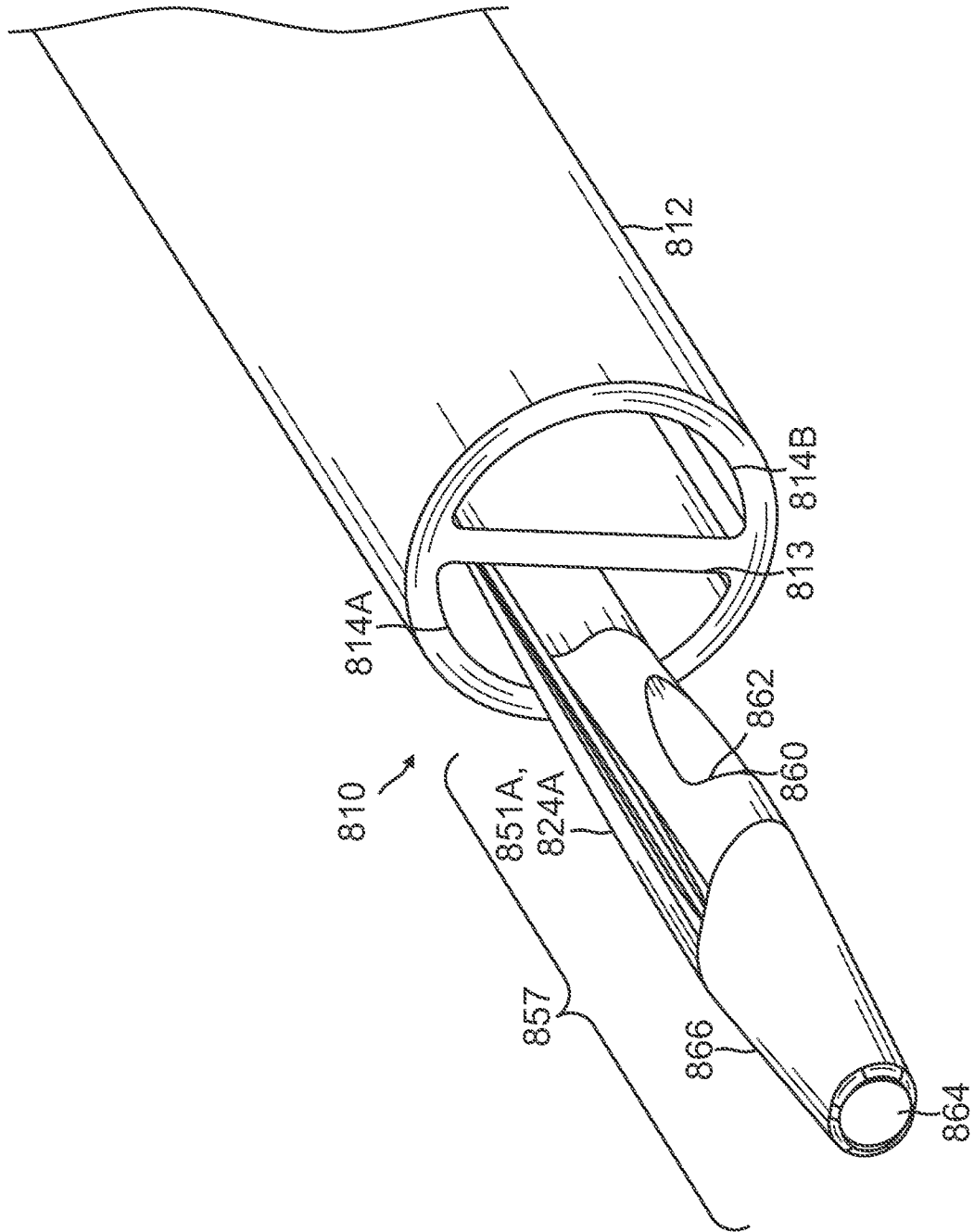

FIG. 22

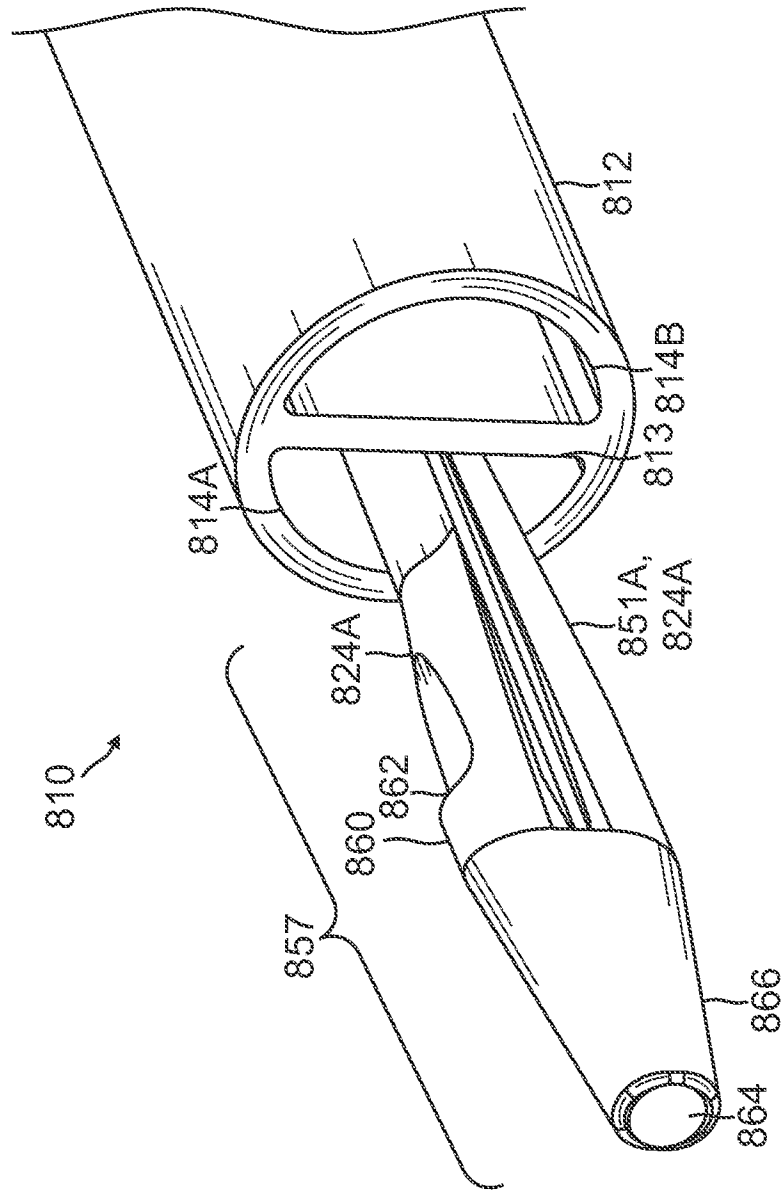

FIG. 23

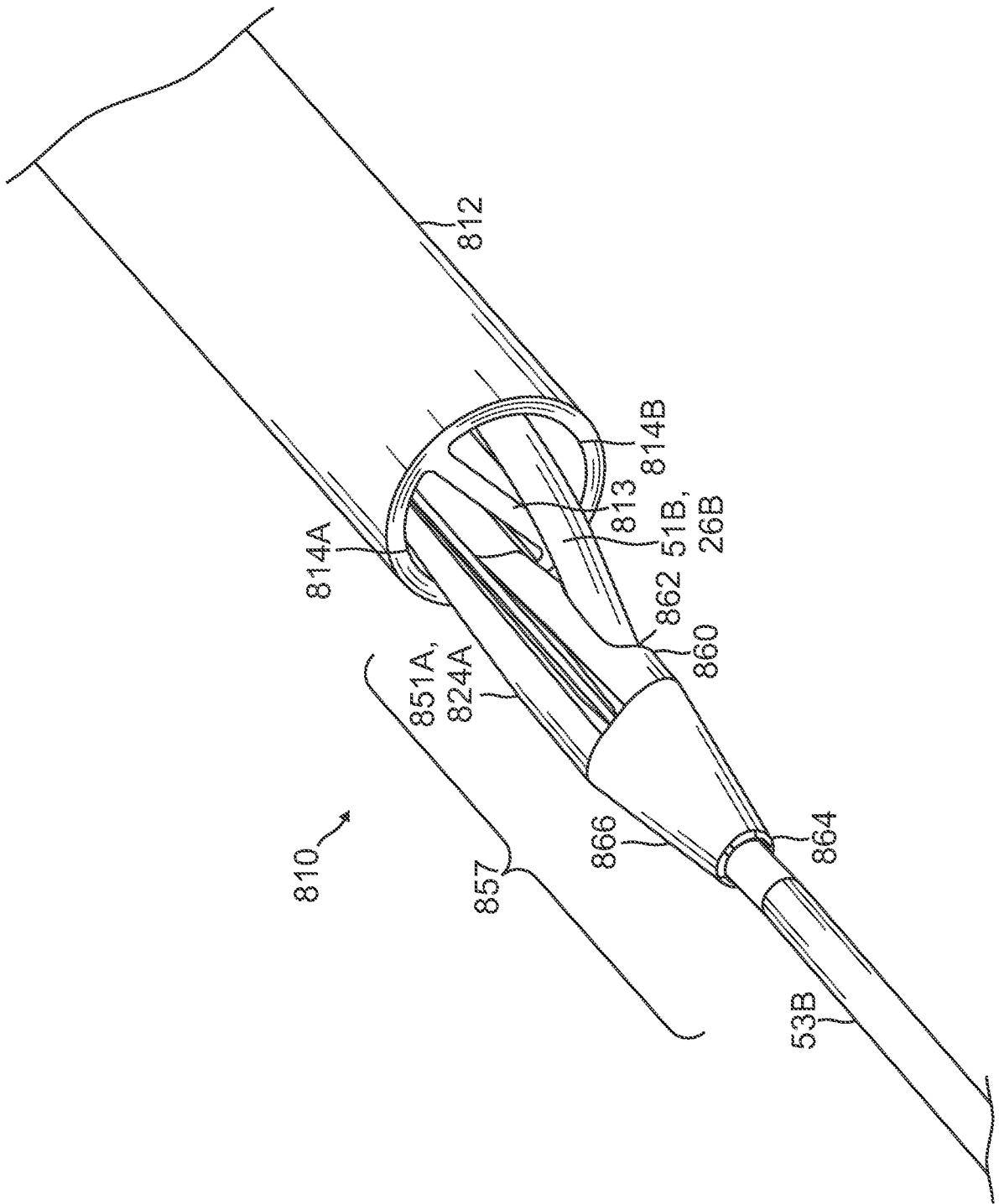

FIG. 24

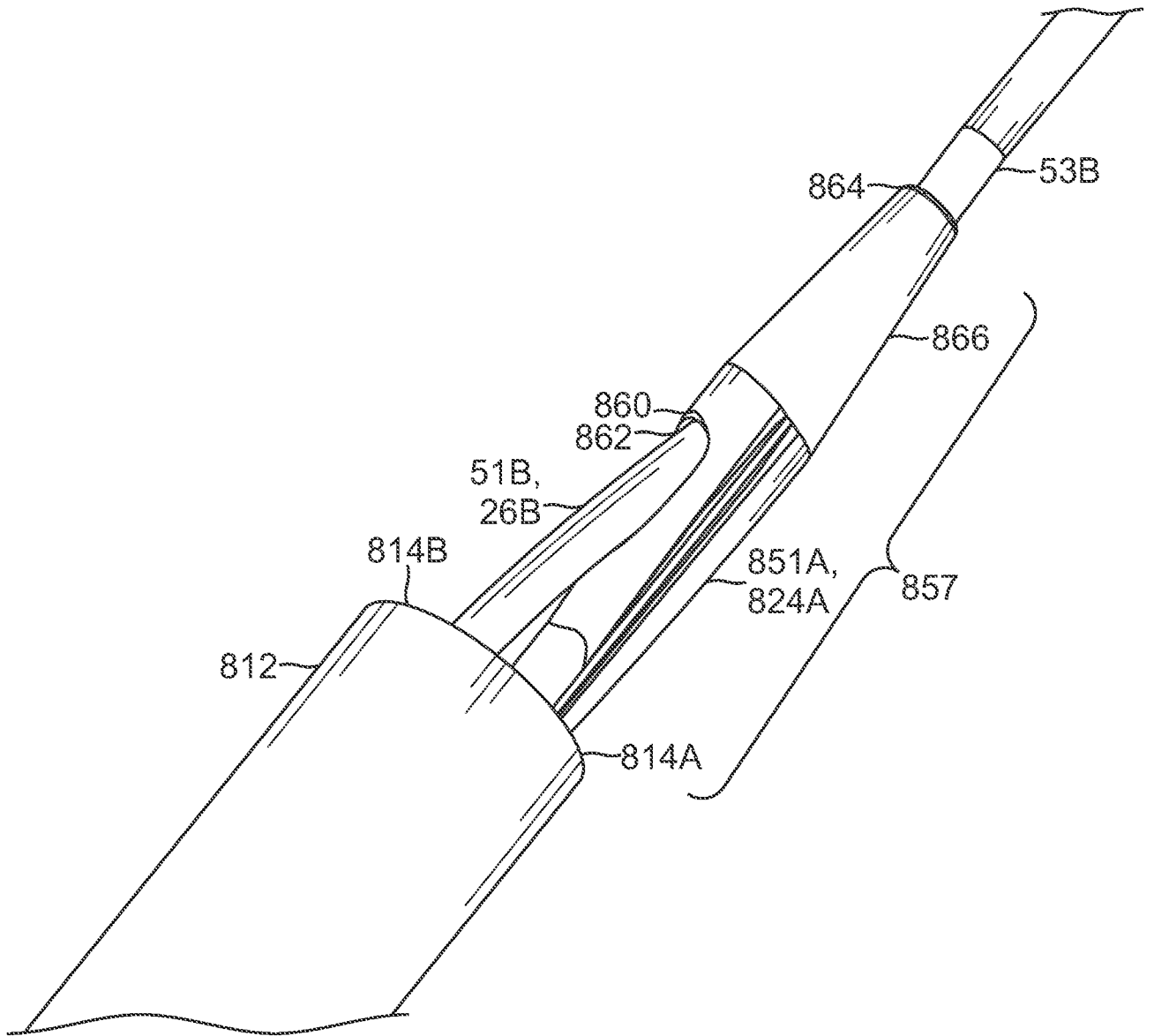

FIG. 25

19/30

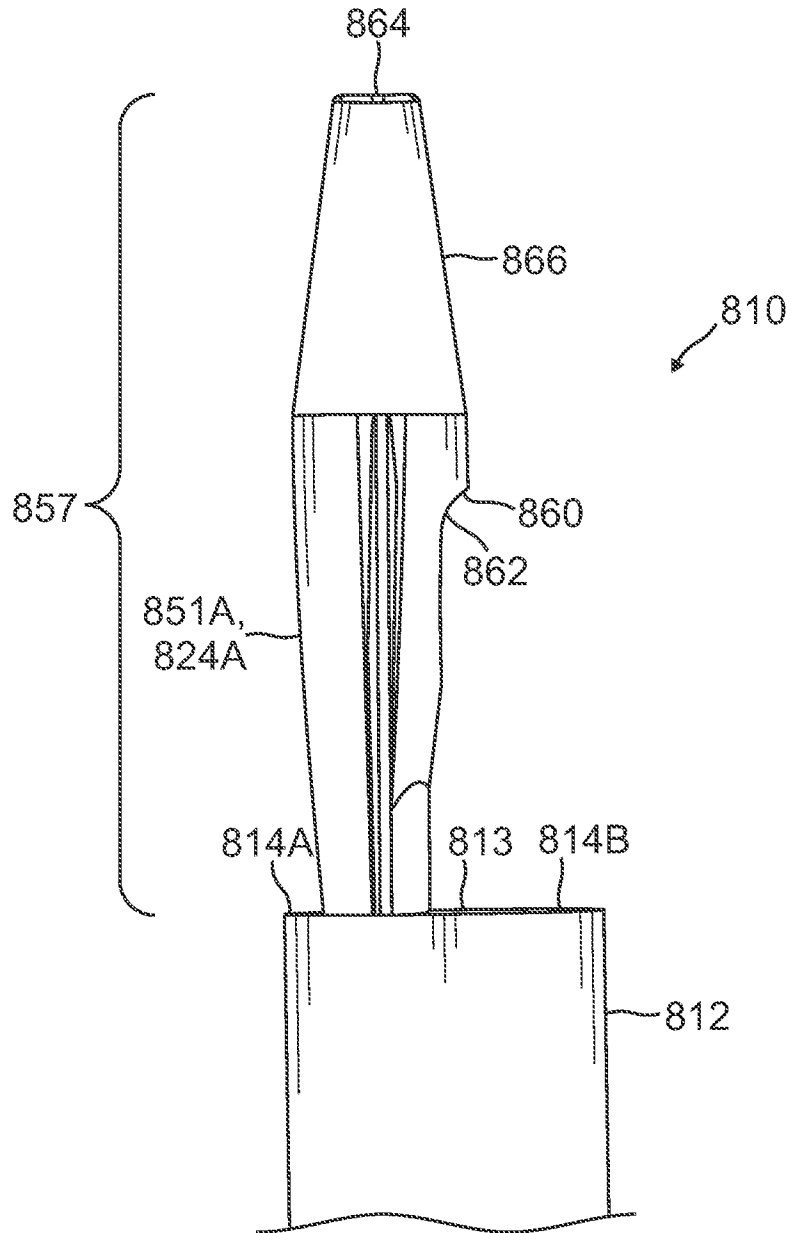

FIG. 26

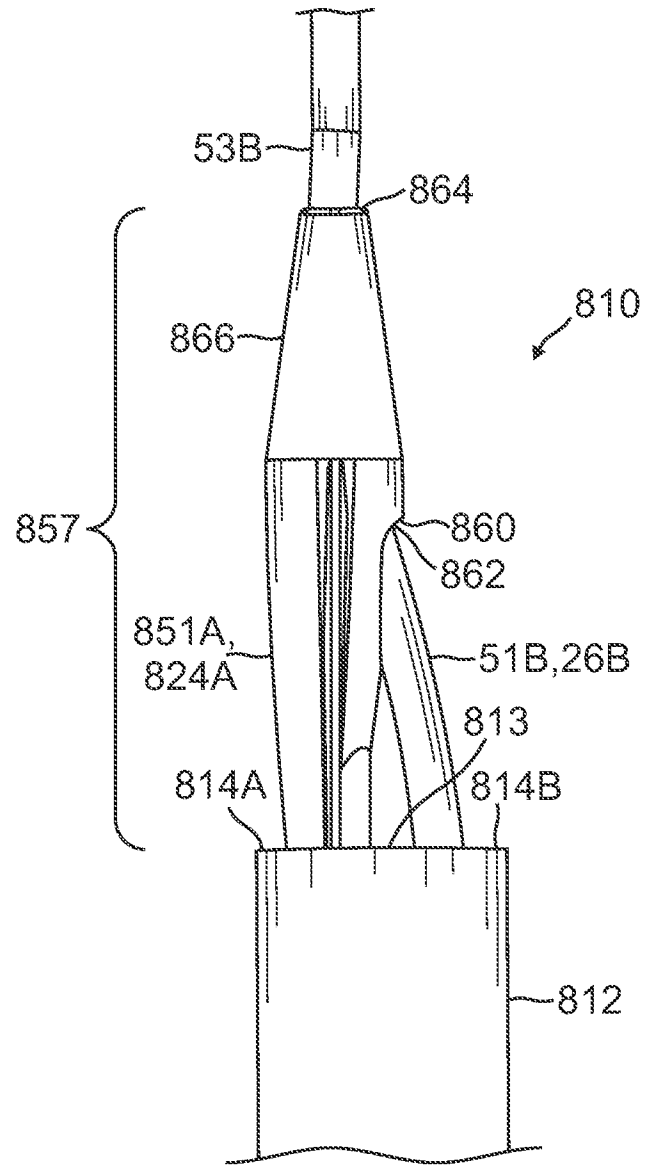

FIG. 27

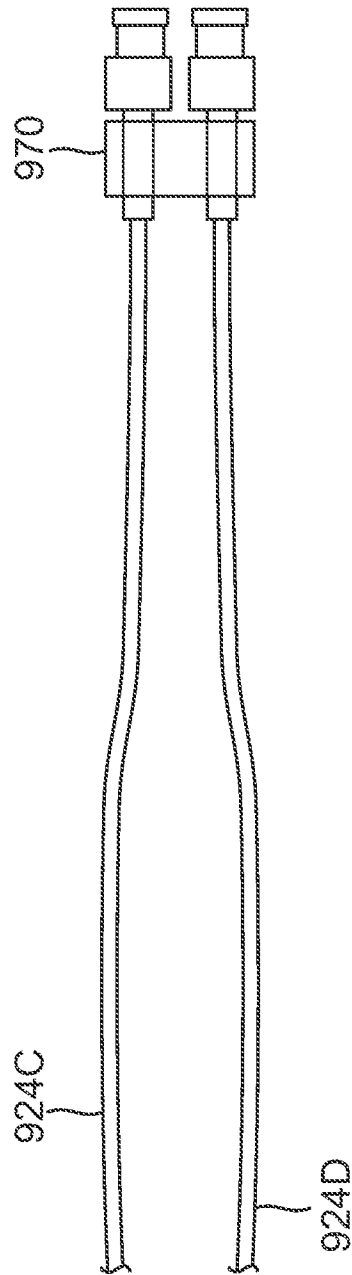

FIG. 28

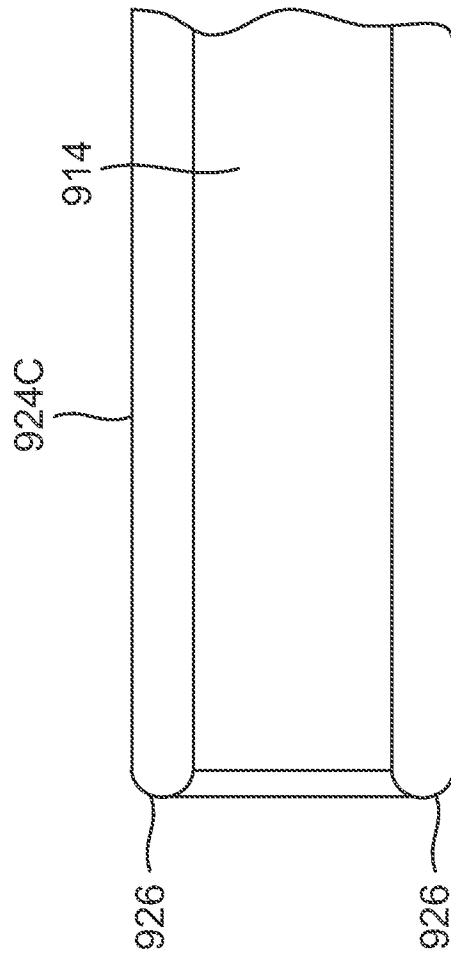

FIG. 29

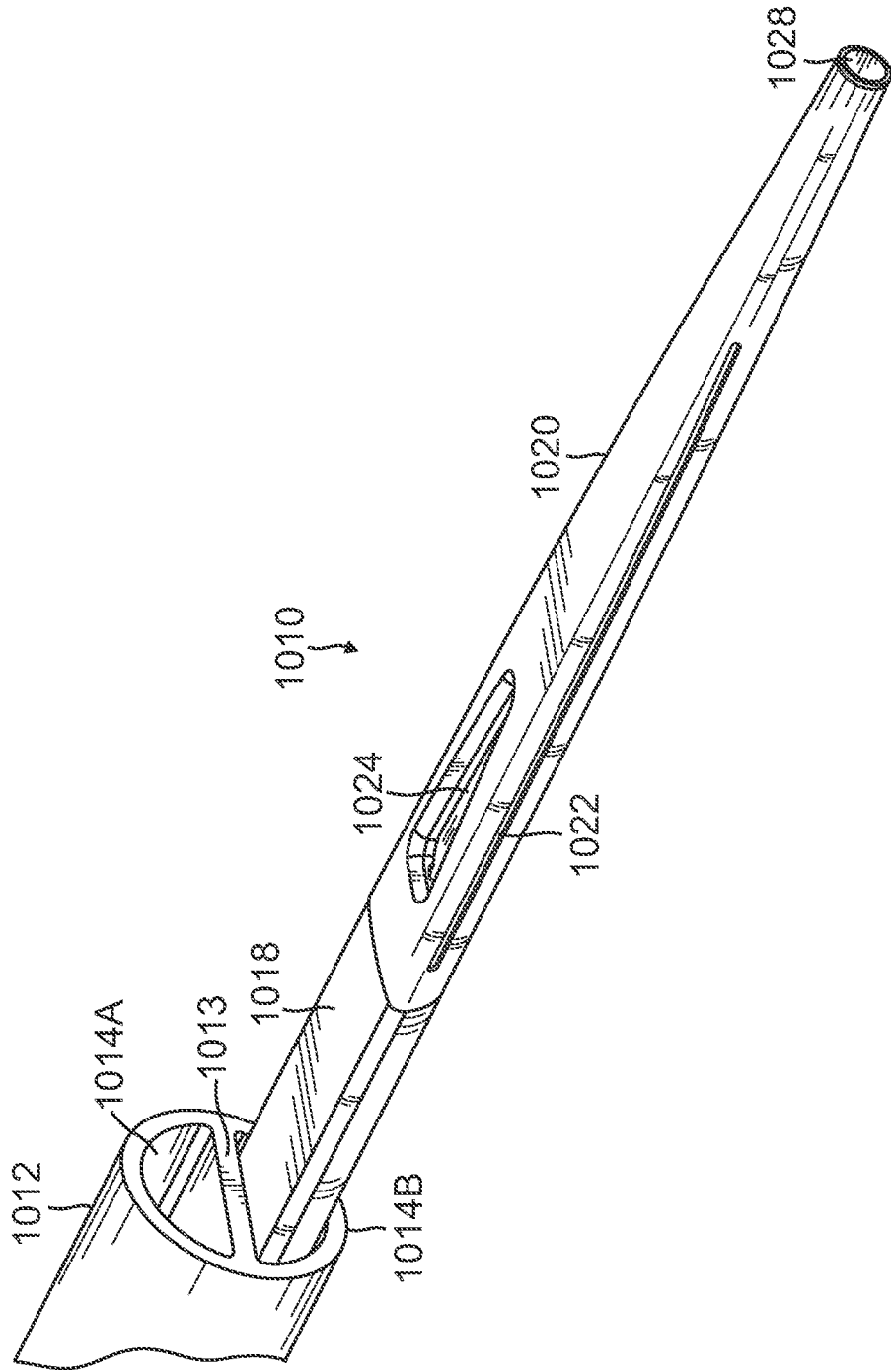

FIG. 30

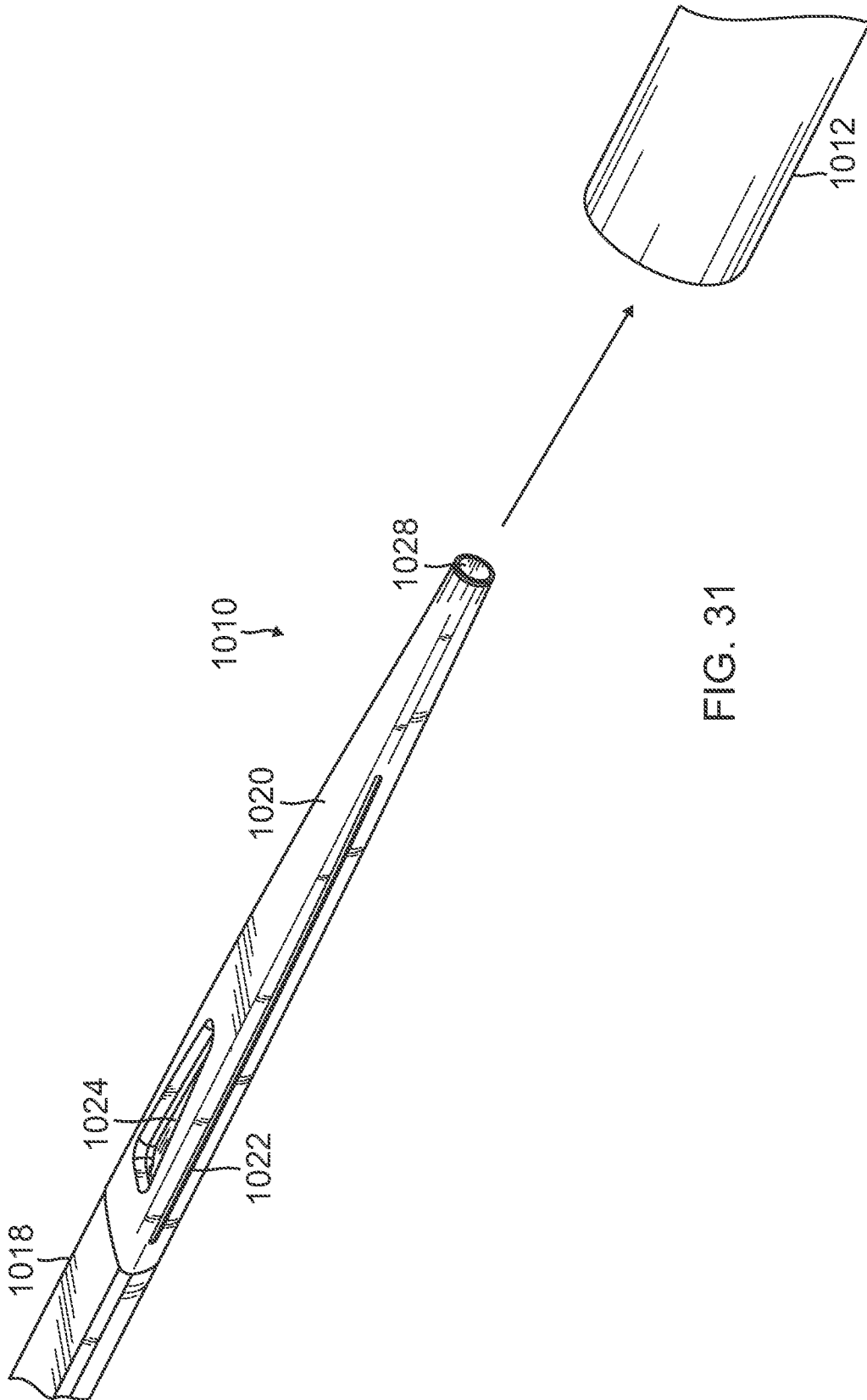

FIG. 31

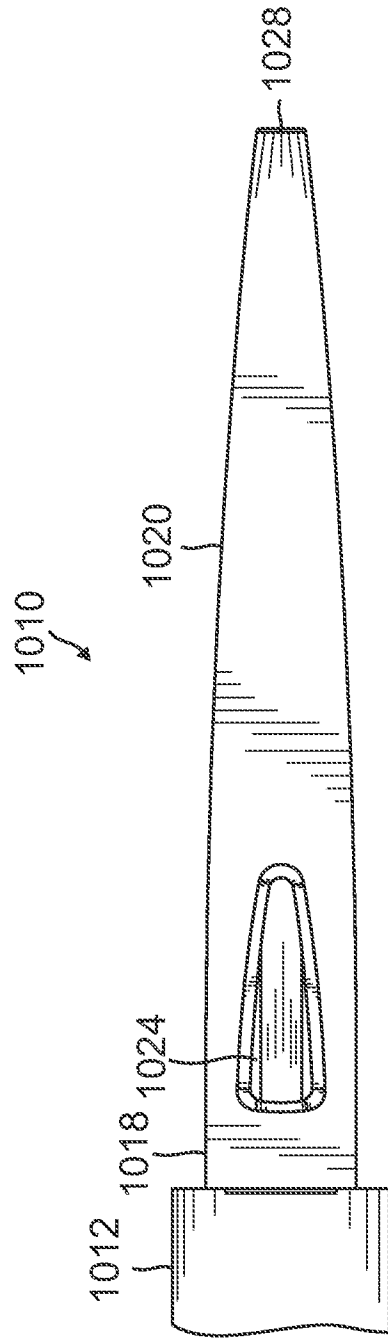

FIG. 32

26/30

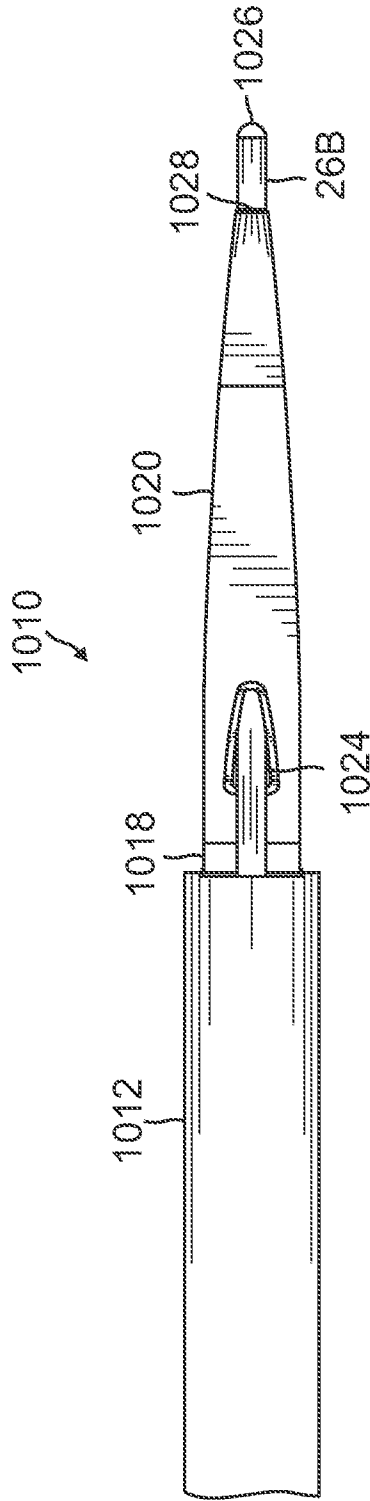

FIG. 33

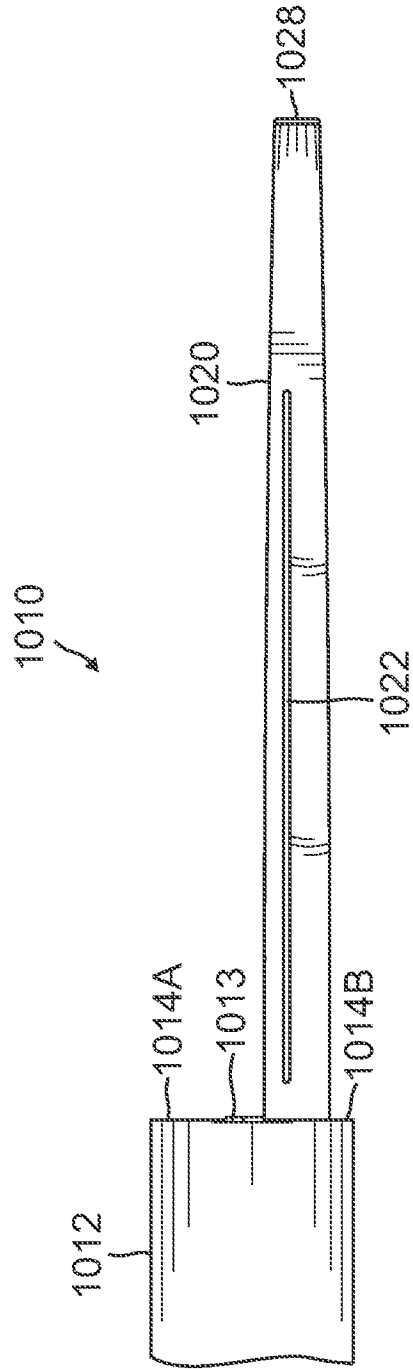

FIG. 34

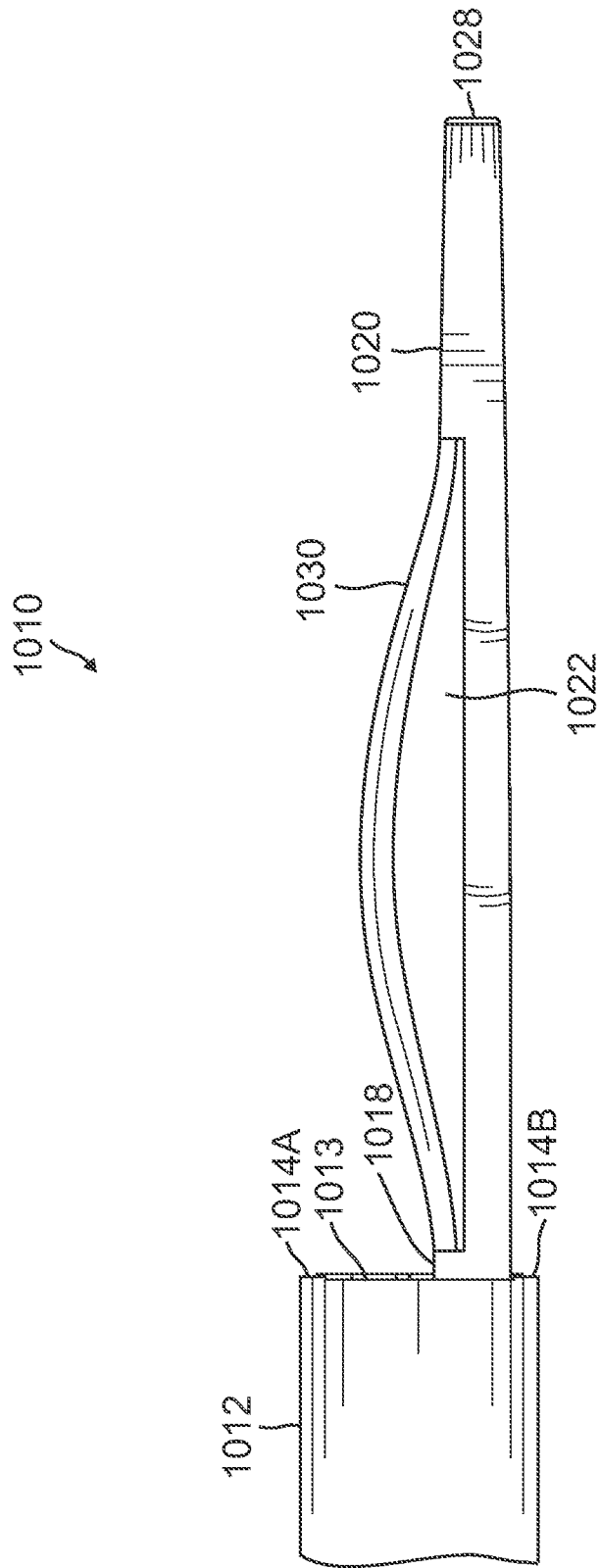

FIG. 35

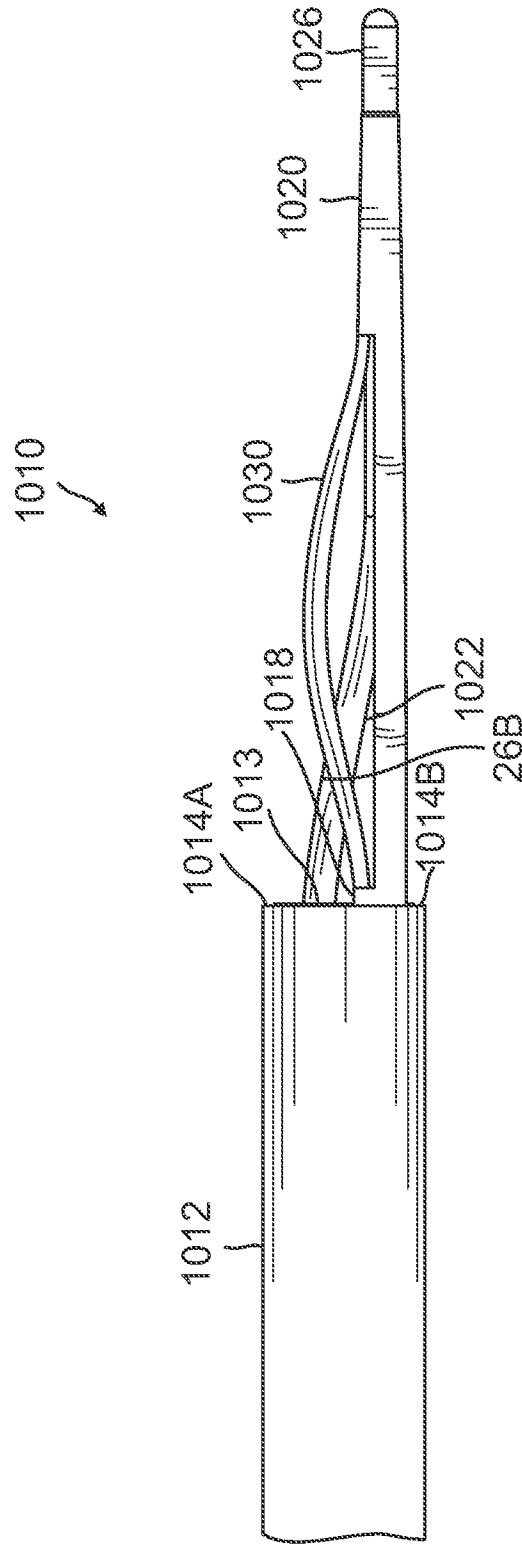

FIG. 36

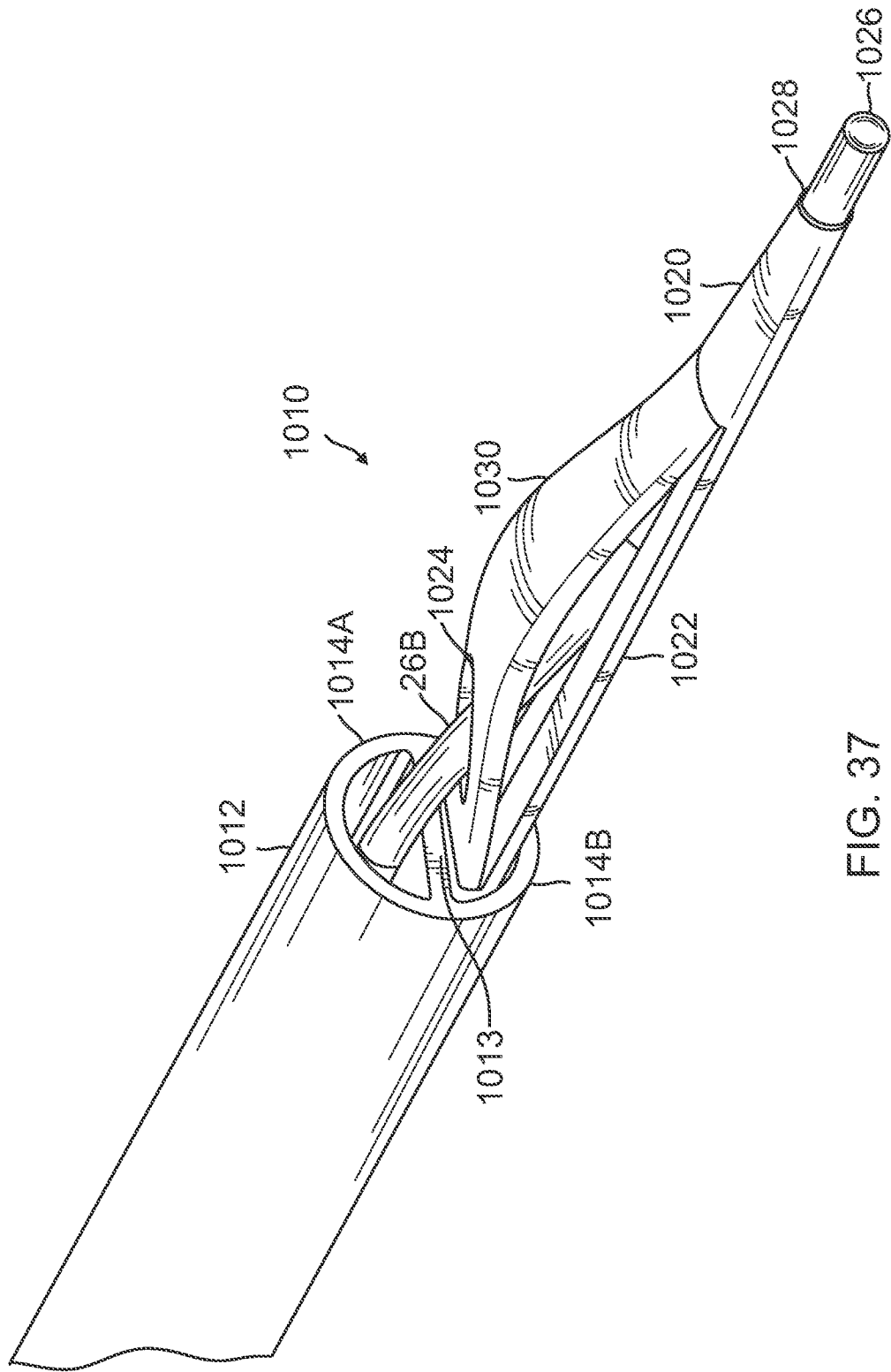

FIG. 37

INTERNATIONAL SEARCH REPORT

International application No.

PCT/US15/40463

A. CLASSIFICATION OF SUBJECT MATTER IPC(8) - A61M 25/01, 25/09, 25/14 (2015.01) CPC - A61M 25/0015, 25/0026, 25/0074 According to International Patent Classification (IPC) or to both national classification and IPC		
B. FIELDS SEARCHED Minimum documentation searched (classification system followed by classification symbols) IPC(8): A61M 25/00, 25/01, 25/09, 25/14 (2015.01) CPC: A61M 25/001, 25/0015, 25/0026, 25/0074, 2025/0188; USPC: 604/43, 173, 264 Documentation searched other than minimum documentation to the extent that such documents are included in the fields searched Electronic data base consulted during the international search (name of data base and, where practicable, search terms used) PatSeer (US, EP, WO, JP, DE, GB, CN, FR, KR, ES, AU, IN, CA, INPADOC Data); Google; Google Scholar; Google Patent; ProQuest. Search terms used: Catheter*, Cannula*, Probe*, Split*, Bifurcat*, Dual*, Multi, Lumen*, Channel*, Conduit*, Stiff*, Guidewir*, Stylet*		
C. DOCUMENTS CONSIDERED TO BE RELEVANT		
Category*	Citation of document, with indication, where appropriate, of the relevant passages	Relevant to claim No.
Y	US 2014/0088510 A1 (BARD ACCESS SYSTEMS, INC.) March 27, 2014; abstract; figures 1-9; paragraphs [0007]-[0008], [0011]-[0013], [0031], [0035], [0043], [0047]; claim 9	1-17
Y	US 4706671 A (WEINRIB, HP) November 17, 1987; figure 104; column 1, lines 57-57; column 2, lines 1-30	1-17
Y	US 2014/0018772 A1 (MERIT MEDICAL SYSTEMS, INC.) January 16, 2014; figures 6-7; paragraphs [0028], [0035], [0041]	3-5, 14-16
<input type="checkbox"/> Further documents are listed in the continuation of Box C. <input type="checkbox"/> See patent family annex.		
* Special categories of cited documents: "A" document defining the general state of the art which is not considered to be of particular relevance "E" earlier application or patent but published on or after the international filing date "L" document which may throw doubts on priority claim(s) or which is cited to establish the publication date of another citation or other special reason (as specified) "O" document referring to an oral disclosure, use, exhibition or other means "P" document published prior to the international filing date but later than the priority date claimed "T" later document published after the international filing date or priority date and not in conflict with the application but cited to understand the principle or theory underlying the invention "X" document of particular relevance; the claimed invention cannot be considered novel or cannot be considered to involve an inventive step when the document is taken alone "Y" document of particular relevance; the claimed invention cannot be considered to involve an inventive step when the document is combined with one or more other such documents, such combination being obvious to a person skilled in the art "&" document member of the same patent family		
Date of the actual completion of the international search 18 September 2015 (18.09.2015)		Date of mailing of the international search report 18 DEC 2015
Name and mailing address of the ISA/ Mail Stop PCT, Attn: ISA/US, Commissioner for Patents P.O. Box 1450, Alexandria, Virginia 22313-1450 Facsimile No. 571-273-8300		Authorized officer Shane Thomas PCT Helpdesk: 571-272-4300 PCT OSP: 571-272-7774

INTERNATIONAL SEARCH REPORT

International application No.

PCT/US15/40463

Box No. II Observations where certain claims were found unsearchable (Continuation of item 2 of first sheet)

This international search report has not been established in respect of certain claims under Article 17(2)(a) for the following reasons:

1. Claims Nos.:
because they relate to subject matter not required to be searched by this Authority, namely:

2. Claims Nos.:
because they relate to parts of the international application that do not comply with the prescribed requirements to such an extent that no meaningful international search can be carried out, specifically:

3. Claims Nos.:
because they are dependent claims and are not drafted in accordance with the second and third sentences of Rule 6.4(a).

Box No. III Observations where unity of invention is lacking (Continuation of item 3 of first sheet)

This International Searching Authority found multiple inventions in this international application, as follows:

This application contains the following inventions or groups of inventions which are not so linked as to form a single general inventive concept under PCT Rule 13.1. In order for all inventions to be examined, the appropriate additional examination fees must be paid.

Group I: Claims 1-17 are directed toward first and second intra-catheter stiffener elements, where the first distal end has a shape capable of receiving the other distal end therein.

Group II: Claims 18-22 are directed toward an expandable stylet tip.

-Continued Within the Next Supplemental Box-

1. As all required additional search fees were timely paid by the applicant, this international search report covers all searchable claims.
2. As all searchable claims could be searched without effort justifying additional fees, this Authority did not invite payment of additional fees.
3. As only some of the required additional search fees were timely paid by the applicant, this international search report covers only those claims for which fees were paid, specifically claims Nos.:
4. No required additional search fees were timely paid by the applicant. Consequently, this international search report is restricted to the invention first mentioned in the claims; it is covered by claims Nos.:
1-17

Remark on Protest

- The additional search fees were accompanied by the applicant's protest and, where applicable, the payment of a protest fee.
- The additional search fees were accompanied by the applicant's protest but the applicable protest fee was not paid within the time limit specified in the invitation.
- No protest accompanied the payment of additional search fees.

INTERNATIONAL SEARCH REPORT
Information on patent family members

International application No.

PCT/US15/40463

Continuation of Box No. III - Observations where unity of invention is lacking:

The inventions listed as Groups I-II do not relate to a single general inventive concept under PCT Rule 13.1 because, under PCT Rule 13.2, they lack the same or corresponding special technical features for the following reasons: the special technical features of Group I include first and second intra-catheter stiffener elements, where the first distal end has a shape capable of receiving the other distal end therein, which is not present in Group II; and the special technical features of Group II include an expandable stylet tip, which is not present in Group I.

The common technical features of Groups I-II are: a catheter apparatus, comprising: a catheter body comprising a first lumen capable of fluid communication via a first distal opening and a second lumen capable of fluid communication via a second distal opening; a first intra-catheter stiffener element configured for disposition through the first lumen such that a distal end thereof is distal in relation to the first distal opening, the first intra-catheter stiffener element comprising at least one of a guide-wire and a stylet; and a second intra-catheter stiffener element configured for disposition through the second lumen such that a distal end thereof is distal in relation to the second distal opening, the second intra-catheter stiffener element comprising a guide-wire, one of the first intra-catheter stiffener element distal end and the second intracatheter stiffener element distal end capable of receiving and accommodating the other of the first intra-catheter stiffener element distal end and the second intra-catheter stiffener element distal end; creating a first incision into a patient; disposing a distal end of the catheter body through the first incision; creating a second incision in a patient, tissue, or blood vessel; disposing the distal end of the catheter body through the second incision; and deforming a portion of the first intra-catheter stiffener element.

These common technical features are disclosed by US 4,706,671 A (WEINRIB). Weinrib discloses a catheter apparatus (abstract), comprising: a catheter body (abstract) comprising a first lumen capable of fluid communication via a first distal opening and a second lumen capable of fluid communication via a second distal opening (lumens 40, 46; figure 3); a first intra-catheter stiffener element configured for disposition through the first lumen such that a distal end thereof is distal in relation to the first distal opening, the first intra-catheter stiffener element comprising at least one of a guide-wire and a stylet (guide wire 41 in lumen 40; figure 3); and a second intra-catheter stiffener element configured for disposition through the second lumen such that a distal end thereof is distal in relation to the second distal opening, the second intra-catheter stiffener element comprising a guide-wire (guide wire 20 in lumen 46; figure 3), one of the first intra-catheter stiffener element distal end and the second intracatheter stiffener element distal end capable of receiving and accommodating the other of the first intra-catheter stiffener element distal end and the second intra-catheter stiffener element distal end (guide wire 20 wraps around guide wire 41 when guide wires 20 and 41 are extended distally of lumens 40 and 46; figure 3; column 3, lines 30-35); creating a first incision into a patient (cutting through skin is intrinsic to inserting the catheter into a blood vessel; column 5, lines 60-65); disposing a distal end of the catheter body through the first incision (inserting the catheter through the skin is intrinsic to inserting the catheter into a blood vessel; column 5, lines 60-65); creating a second incision in a patient, tissue, or blood vessel (cutting into a blood vessel; the needle end 13a of the catheter 10 is used to penetrate the vessel 17 and the wire member 20 will be extended; column 5, lines 60-65); disposing the distal end of the catheter body through the second incision (placing the catheter into the blood vessel; column 5, lines 60-65; figure 3); deforming a portion of the first intra-catheter stiffener element (guide wire 20 wraps around guide wire 41 when guide wires 20 and 41 are extended distally of lumens 40 and 46, and guide wire 20 thereafter flexes, expands, and contracts in response to movements of guide wire 41; figure 3; column 3, lines 30-35).

Since the common technical features are previously disclosed by Weinrib, these common features are not special and so Groups I-II lack unity.