

(19)



Europäisches Patentamt
European Patent Office
Office européen des brevets



(11)

EP 0 432 996 B1

(12)

EUROPEAN PATENT SPECIFICATION

(45) Date of publication and mention of the grant of the patent:
24.07.1996 Bulletin 1996/30

(51) Int Cl.⁶: **G07F 9/00**, G07F 3/02,
G07D 1/00, G07D 5/04,
G07D 5/06, G07D 5/08

(21) Application number: **90313396.5**

(22) Date of filing: **10.12.1990**

(54) Coin release verification

Vorrichtung zur Bestätigung der Abgabe von Münzen

Dispositif pour la vérification de la délivrance de pièces de monnaie

(84) Designated Contracting States:
GB NL

• **Murray, Stephen John**
Littleover, Derby (GB)

(30) Priority: **14.12.1989 GB 8928256**

(74) Representative: **Ford, Michael Frederick et al**
MEWBURN ELLIS
York House
23 Kingsway
London WC2B 6HP (GB)

(43) Date of publication of application:
19.06.1991 Bulletin 1991/25

(73) Proprietor: **MAYGAY MACHINES LIMITED**
Wolverhampton WV10 8AW (GB)

(56) References cited:
EP-A- 0 015 724 **EP-A- 0 209 842**
EP-A- 0 261 838 **WO-A-83/00400**
CH-A- 645 201 **DE-A- 3 121 446**
GB-A- 2 168 185 **GB-A- 2 178 212**

(72) Inventors:
• **Hopkins, Jon**
Perton, Wolverhampton WV6 7SS (GB)
• **Powell, Andrew**
Littleover, Derby (GB)

EP 0 432 996 B1

Note: Within nine months from the publication of the mention of the grant of the European patent, any person may give notice to the European Patent Office of opposition to the European patent granted. Notice of opposition shall be filed in a written reasoned statement. It shall not be deemed to have been filed until the opposition fee has been paid. (Art. 99(1) European Patent Convention).

Description

This invention relates to verifying the release of coins by machines.

Various types of machine have the function of releasing a coin from a store of coins contained within the machine. Vending machines may be equipped to release coins in order to give change. Gaming machines may release coins as prizes. Machines may be constructed to dispense coins of one denomination in exchange for notes or coins of a different denomination.

Mechanisms to effect the release of a coin from a quantity of coins are known. In particular a pay-slide mechanism is known for this purpose. With such a mechanism a vertical tube holds a stack of coins. At the bottom of the tube is a plate which supports the coins but has a cavity able to accommodate a single coin from the bottom of the stack. The plate is attached to a solenoid which, when energised causes rapid movement of the plate. Because the plate has a cavity able to accommodate a single coin, the movement of the plate has the effect of displacing the bottom coin from the stack into a position from which it can fall or roll, e.g. down a chute, to a place where it is accessible to the intended recipient.

One possible malfunction of a coin-releasing mechanism of this nature would occur if the supply of coins above the solenoid-operated slide were to become stuck in the tube surrounding them, for instance because of some sticky substance adhering to one of the coins when put into the tube.

It is already known to guard against this possibility by providing a mechanism able to detect the passage of a coin after it is released by the mechanism.

In the prior art, DE-A-3121446 describes a coin counting device having a pusher which pushes a coin out from the bottom of a stack of coins, the coin displacing a counting arm positioned in the coin release chute as it is pushed from the stack, thereby providing a means for counting the coins.

Use of a piezo electric element to signal that a coin has been inserted into a machine and to switch on electronic circuitry is disclosed in GB-A-2168185.

The present invention seeks to provide for the verification of coin release in a manner which is simple and inexpensive to implement.

According to the present invention we provide a machine which incorporates a coin release mechanism, a machine control system which initiates operation of the coin release mechanism, and coin release verification means for detecting any malfunction of the coin release mechanism wherein operation thereof fails to release a coin, the verification means comprising a piezo-electric element positioned to be struck by a coin after release thereof, and circuitry electrically connected to the piezo-electric element to provide an electrical signal to the control system when a released coin strikes the piezo electric element to verify that the operation of the coin

release mechanism has released a coin.

It is preferred that the piezo electric element is laminar in shape: it may for example be provided by a thin square or rectangle of material having piezo electric properties. Such material is available from Pennwalt Piezo Film Limited, Dunfermline, Scotland.

The piezo electric element may be held by a resiliently deformable support which itself is attached to the structure of the machine. Such interposition of a resiliently deformable carrier between the piezo electric element itself and the rigid structure of the machine can help to isolate the piezo electric element from vibration and enable it to be more responsive to impact from a released coin.

Circuitry to which the piezo electric element is connected must serve to generate an output signal when a coin strikes the piezo electric element. This output signal can then be used by a control mechanism of the machine. The signal might be used in various ways as may be desired for the operation of the whole machine. One simple possibility would be to arrange that (i) when the control mechanism of the machine caused the release of coin, for example by energising the solenoid of the release mechanism, it also caused an indicator lamp to light, (ii) the signal from the piezo electric element and its associated circuitry caused the indicator lamp to go out. In the event of proper functioning of the machine the indicator lamp would not remain alight when the coin was released. If the indicator lamp did remain alight it would indicate a malfunction.

The circuitry connected to the piezo electric element may take various forms. A preferred possibility which has the advantage of requiring only a fairly small number of components utilises an operational amplifier connected to give decaying positive feedback. With such an arrangement the pulse produced by the piezo electric element when struck by a coin is processed by the operational amplifier and the amount of positive feedback serves to determine the length of the generated pulse from the operational amplifier. The resulting signal, processed and shaped by means of the operating amplifier could then serve as an input to logic circuitry.

An embodiment will now be described in more detail, by way of example only, and with reference to the accompanying drawings in which:

Fig. 1 is a cross sectional view of a conventional pay-slide fitted with a piezo electric element in accordance with this invention.

Fig. 2 is a diagrammatic illustration of the mounting of a piezo electric element, and

Figs. 3, 4 and 5 are circuit diagrams.

As shown by Fig. 1 the pay-slide has a tube 10 to contain a vertical stack of coins 12. At the base of the tube there is a plate 14 which acts as a stop to prevent coins falling from the tube. This plate 14 is part of a

bracket 16 on which is mounted a solenoid 18. The plate 14 is spaced slightly below the bottom of the tube 10 and a plunger 20 is shaped so as to project into the gap between the plate 14 and the tube 10. The plunger constitutes the armature of the solenoid 18 or is connected to the armature. The plunger is urged towards the position illustrated by a spring. When the solenoid 18 is energised the plunger is drawn to the left into the solenoid against the reaction of the spring.

The stack of coins normally rests on top of the finger 22 which projects from the plunger 20. When it is required to dispense a coin the solenoid 18 is energised pulling the plunger 20 to the left and pulling out the finger 22 from beneath the bottom coin of the stack. The stack drops until the bottom coin rests on the stop 14. Then when the solenoid is de-energised the plunger returns and the finger 22 pushes the bottom coin (but only the bottom coin) to the right. The coin strikes an end wall 26 as shown by the coin drawn in chain-dotted lines at the position indicated as 24. The coin then falls further as indicated by the coin shown in chain lines at 28 into a chute (not shown) which guides the falling coin to a tray from which it can be picked up by the user.

As so far described the pay-slide mechanism is a conventional one. In accordance with this invention however a laminar piece of piezo electric film 30 is attached to the end wall 26 so that it will be struck by a released coin when the coin strikes the end wall as is illustrated at the position 24.

The piezo electric film may be attached by an adhesive layer on its rear surface. Alternatively, as shown by the more detailed Fig. 2, the piezo electric film 30 is attached to the end wall 26 of the pay-slide mechanism by means of a piece 32 of double-sided adhesive material. This piece is somewhat resilient and provides some isolation of the piezo electric element from mechanical vibration. Connections to the piezo electric element 30 are connectors crimped to it at two spaced apart positions, one behind the plane of Fig. 1 and one in front of the plane of Fig. 1.

The electrical circuit which is used to obtain a useful signal from the piezo electric element is shown in Fig. 3. The piezo electric element 30 is connected to the non-inverting input of an operational amplifier 34. The inverting input of the operational amplifier is held at a constant voltage by the resistors R1 and R2. The output from the operational amplifier is connected back to the non-inverting input via capacitor C1. That input is also connected to ground through capacitor C2 and resistor R3.

When the circuit is quiescent, the input of the operational amplifier is held at ground through the resistor R3. When a coin strikes a piezo electric element it produces a transient voltage which is amplified by the operational amplifier. The connection to the non-inverting input through capacitor C1 gives positive feedback so the initial transient voltage generated by the piezo electric element is processed to provide a lengthened output pulse. The length of the output pulse is determined by

the time taken to return the non-inverting input of the operational amplifier to ground. The output from this circuit on line 36 is a square wave pulse which can be used by the controls of the machine. The presence of this output pulse at the appropriate time confirms that a coin actually has been pushed off the bottom of the stack in the tube 10 so as to strike the end wall 26.

The present invention thus provides verification while only requiring the addition of the piezo electric element (and possibly double-sided adhesive material) to the conventional pay-slide mechanism and requiring only a simple circuit to convert the output from the piezo electric element itself into a useful electrical signal.

Fig. 4 illustrates by way of example a possible and simple circuit to make use of the verification. The signal on line 40 to energise the relay 18 is coupled through capacitor C4 and Schmitt trigger 42 to one input of an RS flip flop 44. This sends line 46 high, causing transistor TR1 to light lamp 48.

The pulse coming from the circuit of Fig. 3 on line 36 is applied to the other input of the flip flop 44, causing the output line 46 to go low and extinguishing the lamp. However, if no coin is released, the absence of this verification signal on line 36 will leave the lamp 48 alight as a warning that the coin release mechanism has failed to deliver.

The signal on line 36 of Fig. 3 could, if desired be amplified and inverted as shown in Fig. 5. The line 36 is connected to the base of transistor TR2. A positive signal on line 36 increases collector current at transistor TR2, so increasing the voltage drop across R4 and hence producing an amplified but inverted signal on line 56.

Another possibility is that the supply on line 58 is not the supply voltage V⁺ but a high frequency square wave signal such as the clock pulse of a control circuit. The presence of a signal on line 36 would then lead to the output of a square wave on line 56, for the duration of the signal on line 36.

An output signal, such as produced on line 36 of Fig. 3 or line 56 of Fig. 5 could be used as input to forms of circuitry other than the outer simple circuit of Fig. 4. It could well serve as input to more elaborate control circuitry of a machine, for this circuitry to making use of the verification signal.

Although here illustrated in connection with a conventional pay-slide mechanism, the invention would also be applicable to other mechanisms for releasing a coin. All that is necessary to implement the invention is to position the piezo electric film where it will be struck reliably by a coin as the coin is released.

Claims

1. A machine which incorporates a coin release mechanism, a machine control system which initiates operation of the coin release mechanism, and coin re-

lease verification means for detecting any malfunction of the coin release mechanism wherein operation thereof fails to release a coin, the verification means comprising a piezo-electric element (30) positioned to be struck by a coin (24) after release thereof, and circuitry electrically connected to the piezo-electric element (30) to provide an electrical signal to the control system when a released coin (24) strikes the piezo electric element (30) to verify that the operation of the coin release mechanism has released a coin.

2. A machine according to claim 1 wherein the circuitry comprises an operational amplifier (34) connected to give decaying positive feedback.
3. A machine according to either one of claims 1 or 2 wherein the circuitry comprises an RS flip-flop (44) connected to receive signal from the operational amplifier.
4. A machine according to any one of the preceding claims wherein the piezo-electric element (30) is laminar.
5. A machine according to any one of the preceding claims wherein the piezo-electric element (30) is held by a resiliently deformable support (32) which is in turn attached to a more rigid structure (26) of the machine.
6. A machine according to any one of the preceding claims wherein the mechanism is a pay-slide having a tube (10) to hold a stack of coins (12), closed by a plate (14) with a cavity for a coin from the stack, and an operating solenoid (18) to move the plate (14) to a position at which the coin in the cavity is released.

Patentansprüche

1. Vorrichtung bzw. Maschine, die einen Münzenfreigabemechanismus, ein Vorrichtungssteuerungssystem, das den Betrieb des Münzenfreigabemechanismus in Gang setzt, und Münzenfreigabeverifizierungsmittel zum Ermitteln jeglicher Fehlfunktion des Münzenfreigabemechanismus umfaßt, bei der durch seinen Betrieb keine Münze freigegeben wird, wobei das Verifizierungsmittel ein piezoelektrisches Element (30) umfaßt, das so angeordnet ist, daß es von einer Münze (24) nach deren Freigabe getroffen wird, sowie eine Schaltung, die elektrisch mit dem piezoelektrischen Element (30) verbunden ist, um an das Steuerungssystem ein elektrisches Signal abzugeben, wenn eine freigegebene Münze (24) das piezoelektrische Element (30) trifft, um zu verifizieren, daß durch den Betrieb des

Münzenfreigabemechanismus eine Münze freigegeben worden ist.

2. Vorrichtung nach Anspruch 1, worin die Schaltung einen Operationsverstärker (34) umfaßt, der so angeschlossen ist, daß er eine abklingende positive Rückkopplung ergibt.
3. Vorrichtung nach Anspruch 1 oder 2, worin die Schaltung ein RS-Flipflop (44) umfaßt, das so angeschlossen ist, daß es vom Operationsverstärker ein Signal empfängt.
4. Vorrichtung nach einem der vorangegangenen Ansprüche, worin das piezoelektrische Element (30) lamellenförmig ist.
5. Vorrichtung nach einem der vorangegangenen Ansprüche, worin das piezoelektrische Element (30) von einer elastisch verformbaren Stütze (32) gehalten wird, die wiederum an einer starrereren Struktur (26) des Vorrichtungsbefestigt ist.
6. Vorrichtung nach einem der vorangegangenen Ansprüche, worin der Mechanismus ein Zahleinwurf mit einer Röhre (10) zum Halten eines Münzenstapels (12) ist, die von einer Platte (14) mit einem Hohlraum für eine Münze vom Stapel geschlossen wird, und einem Betriebssolenoid (18), um die Platte (14) in eine Position zu bewegen, in der die Münze im Hohlraum freigegeben wird.

Revendications

1. Machine qui incorpore un mécanisme de relâchement de pièces de monnaie, un système de commande de machine qui initie le fonctionnement du mécanisme de relâchement de pièces de monnaie et un moyen de vérification du relâchement de pièces de monnaie pour détecter tout fonctionnement erroné du mécanisme de relâchement de pièces de monnaie où le fonctionnement de celui-ci omet de relâcher une pièce de monnaie, le moyen de vérification comprenant un élément piézo-électrique (30) positionné pour être heurté par une pièce de monnaie (24) après le relâchement de celle-ci, et un circuit relié électriquement à l'élément piézo-électrique (30) pour fournir un signal électrique au système de commande lorsqu'une pièce de monnaie relâchée (24) heurte l'élément piézo-électrique (30) pour vérifier que l'opération du mécanisme de relâchement de pièces de monnaie ait relâché une pièce de monnaie.
2. Machine selon la revendication 1, où le circuit comprend un amplificateur opérationnel (34) relié pour fournir une contre-réaction positive décroissante.

3. Machine selon l'une des revendications 1 ou 2, où le circuit comporte une bascule SR (44) connectée pour recevoir des signaux de l'amplificateur opérationnel.
- 5
4. Machine selon l'une des revendications précédentes, où l'élément piézo-électrique (30) est laminaire.
5. Machine selon l'une des revendications précédentes, où l'élément piézo-électrique (30) est retenu par un support (32) élastiquement déformable qui est à son tour fixé à une structure (26) plus rigide de la machine.
- 10
6. Machine selon l'une des revendications précédentes, où le mécanisme est une goulotte de paiement présentant un tube (10) pour tenir une pile de pièces de monnaie (12), fermée par une plaque (14) avec une cavité pour une pièce de monnaie de la pile, et un solénoïde actif (18) pour amener la plaque (14) dans une position à laquelle la pièce de monnaie dans la cavité est relâchée.
- 15
- 20

25

30

35

40

45

50

55

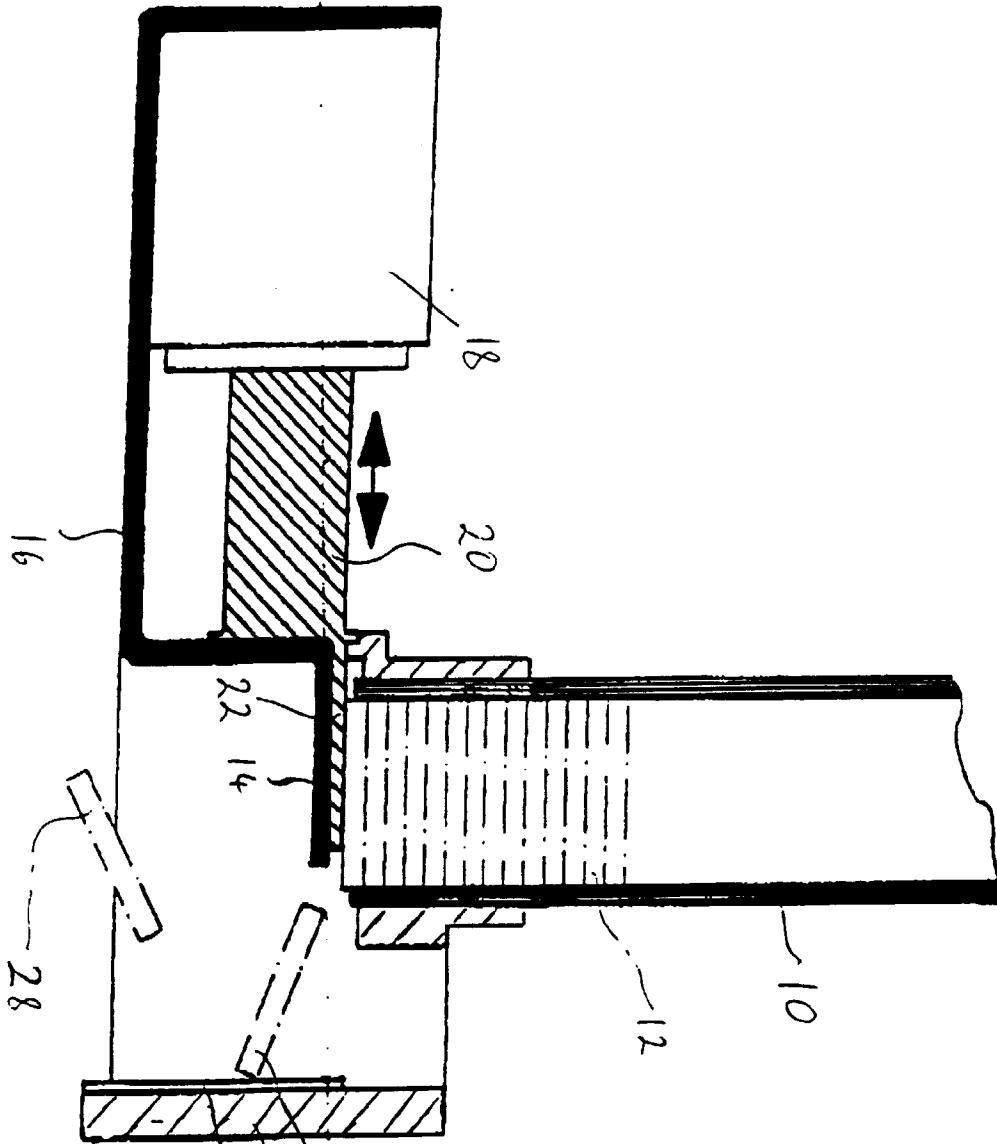

Fig 1

PIEZO FILM
30

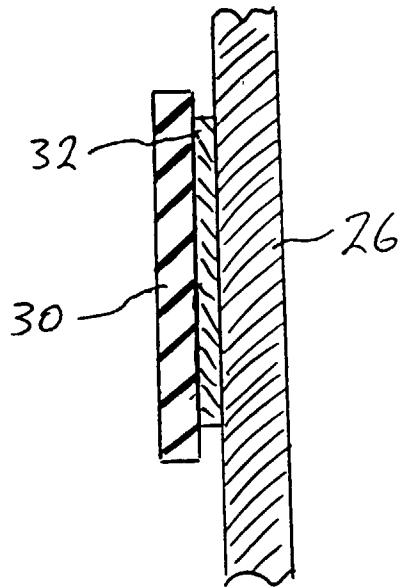

Fig 2

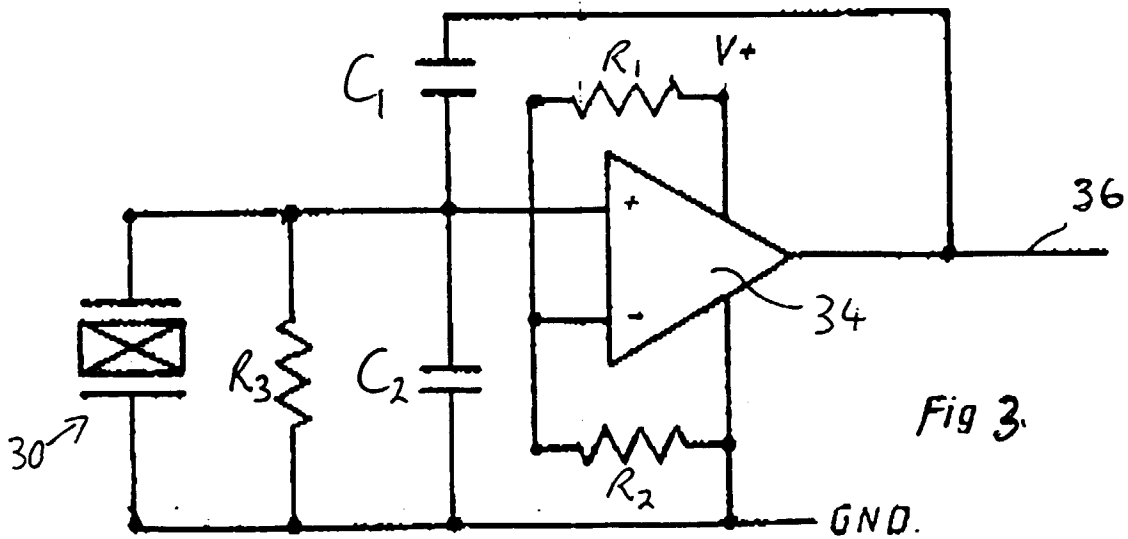

Fig 3.

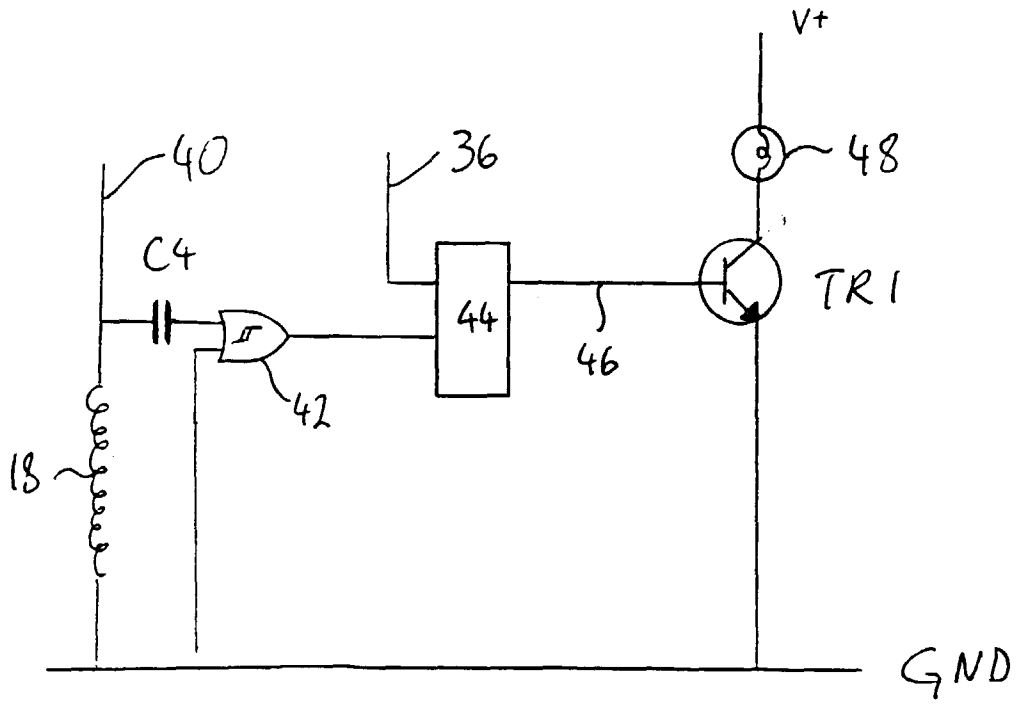

Fig 4

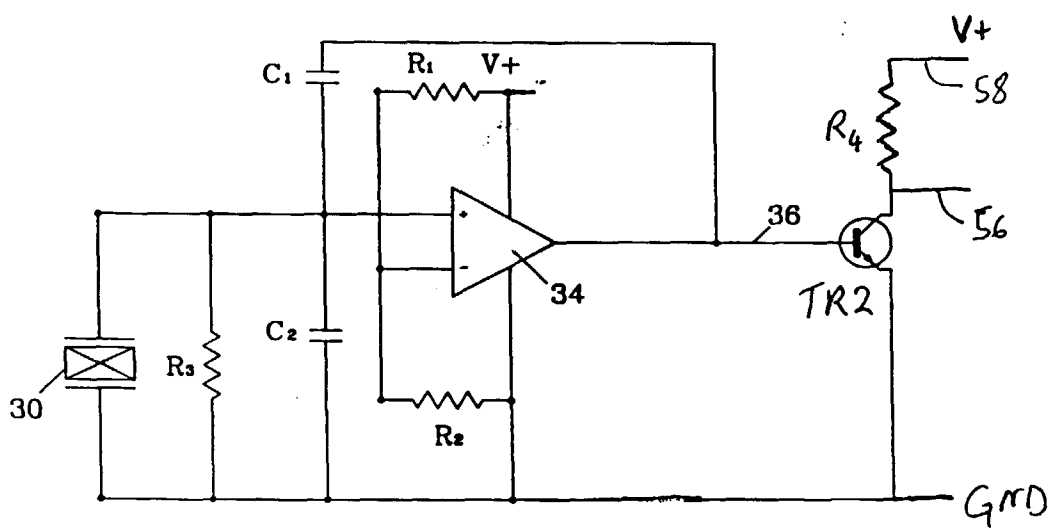

Fig 5