

April 18, 1933.

P. V. VANDELDELDE
CONTINUOUS ALARM CLOCK

1,904,579

Filed Oct. 21, 1930

2 Sheets-Sheet 1

Fig. 1.

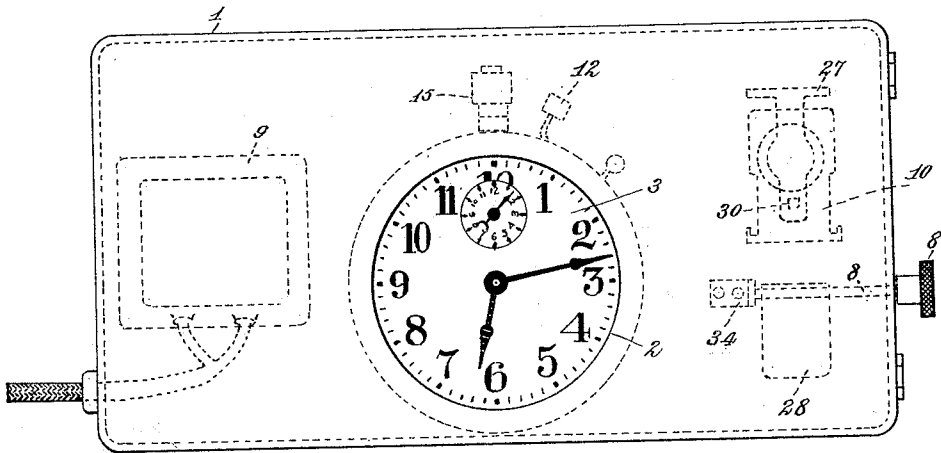
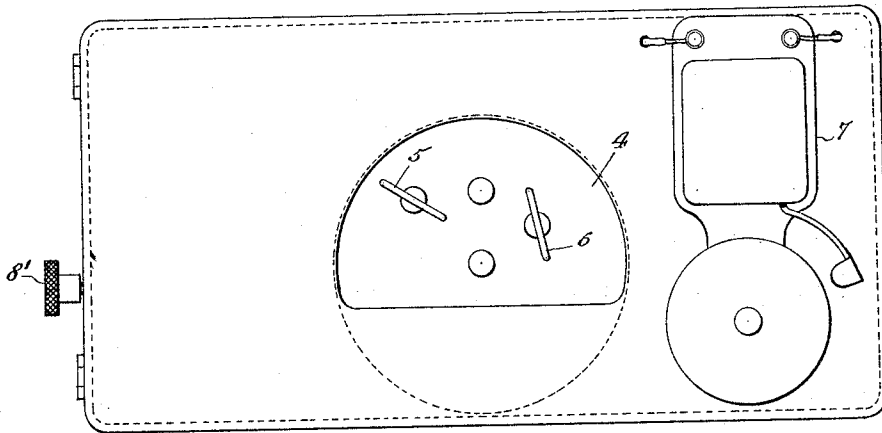

Fig. 2.



WITNESSES
William S. Goebel
A. L. Kitchin

INVENTOR
Paul V. Vandevelde
BY *Mum & Co.*
ATTORNEYS

April 18, 1933.

P. V. VANDELDELDE

1,904,579

CONTINUOUS ALARM CLOCK

Filed Oct. 21, 1930

2 Sheets-Sheet 2

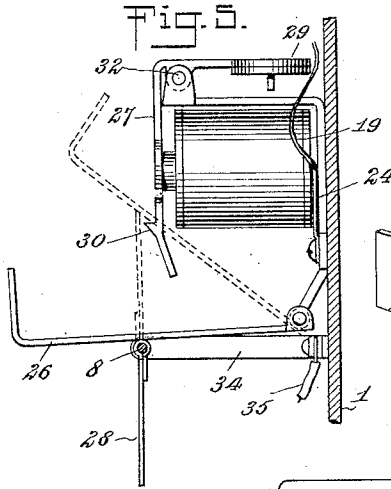
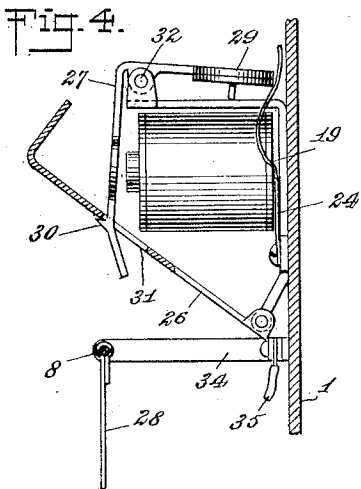
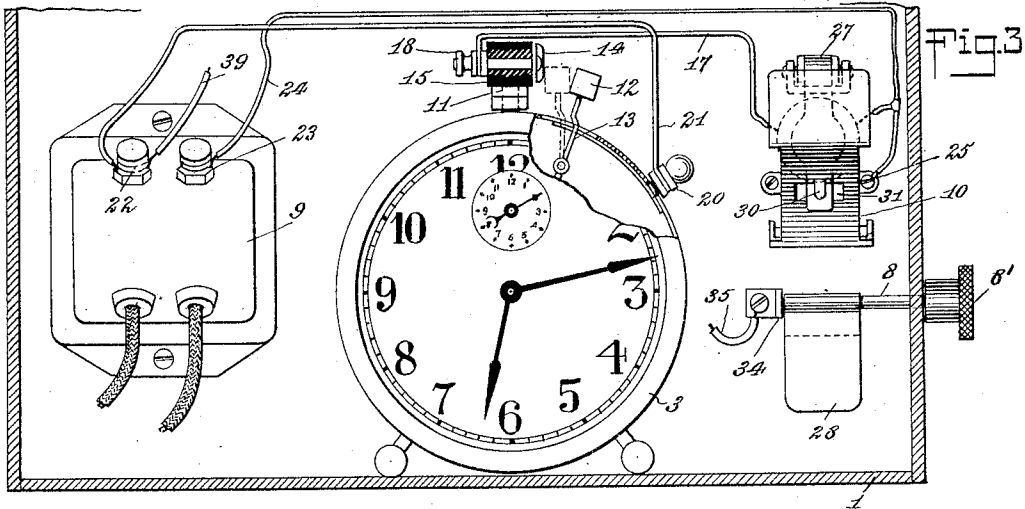

Fig. 6.

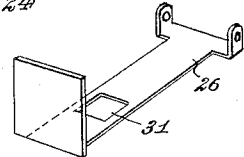

Fig. 7.

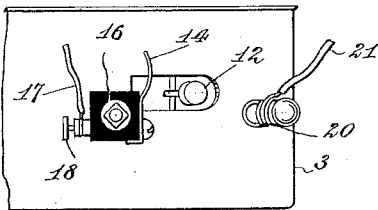
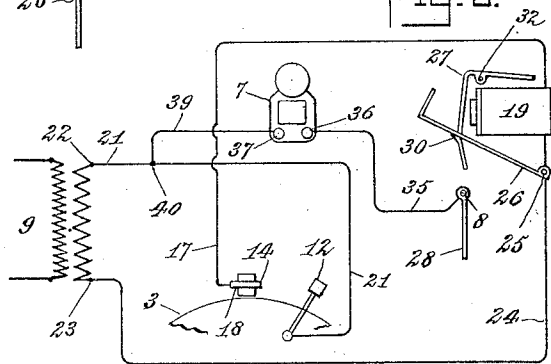

Fig. 8.



WITNESSES
William P. Goebel
A. L. Stetson

INVENTOR
Paul V. Vandeveldde
BY *Munn & Co.*
ATTORNEYS

UNITED STATES PATENT OFFICE

PAUL V. VANDEVELDE, OF NEW YORK, N. Y.

CONTINUOUS ALARM CLOCK

Application filed October 21, 1930. Serial No. 490,304.

This invention relates to an alarming device and particularly to what may be termed a continuous alarm clock, the object being to provide an improved construction wherein a commercial alarm clock is connected with a switch and other devices in such a manner that when the alarm of the clock begins to operate an electrically operated bell will begin to function and will continue to function until manually turned off.

Another object of the invention is to provide an alarm device wherein house current is transformed or reduced in voltage to act with an ordinary door bell or other electrically operated bell, the parts being associated so that an alarm clock will close the circuit of the bell and said circuit will remain closed until manually opened, thus causing a continuous alarm until manually shut off.

A further object, more specifically, is to provide in connection with a commercial alarm clock an electrically operated bell and a switch therefor constructed and positioned to normally hold the bell circuit open and to close the bell circuit and maintain the same closed when the alarm mechanism of the alarm clock begins to function.

In the accompanying drawings—

Figure 1 is a front view of a continuous alarm clock disclosing an embodiment of my invention;

Figure 2 is a rear view of the structure shown in Figure 1;

Figure 3 is a longitudinal vertical section through the casing shown in Figure 1, the same illustrating in elevation the various interior parts;

Figure 4 is a side view on an enlarged scale of the electrical switch shown in Figure 3;

Figure 5 is a view similar to Figure 4 but showing the switch operated or closed;

Figure 6 is a perspective view of the switch arm shown in Figures 4 and 5;

Figure 7 is a top plan view of part of the clock shown in Figure 3, together with the electric connections associated therewith;

Figure 8 is a diagram showing the wires and other parts properly connected up as illustrated in elevation in Figure 3.

Referring to the accompanying drawings

by numerals, 1 indicates a casing which is provided with an opening 2 through which the ordinary commercial alarm clock 3 may be seen. The casing 1 may be made of metal, wood or other desired material and is shown as being rectangular, although it could be made of any other shape without departing from the spirit of the invention. In fact, the casing 1 could be made to represent any shape of conventional clock and may also be provided with short supporting legs, although these features are not essential to the invention.

As shown in Figure 2 there is provided an opening 4 at the back whereby the winding arbor for winding the main spring winding arbor 6 and other parts are exposed to the operator's hand, thus permitting winding of the clock at any time, and also to enable the operator to wind the alarm arbor. An ordinary commercial door bell 7 is represented in Figure 2, but it is evident that any kind of electrically operated bell may be used, although the ordinary door bell is desirable because it is inexpensive and very efficient. Preferably the bell 7 is positioned on the outside of the casing 1, while all the other parts are positioned interiorly except the thumb member 8 which rotates the shaft 8 and other parts as hereinafter duly described.

As shown particularly in Figure 3 the invention includes the association of a transformer 9 in connection with the clock 3 with the switch 10 and with the other parts.

The transformer 9 may be any desired transformer as shown in Figure 8 in a conventional manner so as to step down the current to six volts or thereabouts, whereby an ordinary door bell may be used. In the commercial alarm clock indicated by the numeral 3 there is always provided a threaded stem 11 which ordinarily carries a bell which is adapted to be struck by the hammer 12 operated from arm 13, which arm is actuated by the usual alarm mechanism within the clock, the specific structure thereof forming no part of the present invention.

In the present invention instead of permitting the hammer 12 to strike the bell mounted

on the threaded stem 11, it strikes a contact 14 carried by an insulating block 15 which block is slipped over the stem 11 and clamped in place by a suitable nut 16, for instance, Figure 7. A wire or other conductor 17 extends from the post 18 which is electrically connected with the contact 14 and extends to one end of the winding of the electro-magnet 19. A post 20 is secured to the casing of clock 3 and acts as means for electrically connecting wire 21 to the casing, said wire extending to the terminal 22 of the transformer 9. The opposite terminal, namely terminal 23, is connected with the wire 24 which wire extends to the opposite end of the wiring of electro-magnet 19 to that connected with wire 21. This wire is also connected at 25 to the arm 26 which is part of the switch 10. It will be noted that switch 10 really includes the electro-magnet 19, contact arm 26, catch 27 and swinging arm 28, which arm is rigidly connected with shaft 8, whereby the arm or plate 28 may be swung from its lower position shown in Figures 4 and 5 to an upper position shown in dotted lines in Figure 5, whereby arm 26 is caused to interlock with the catch 27. Catch 27 is an L-shaped structure having a counterweight 29 and a catch spur 30 adapted to pass through the opening 31 in arm 26 and then interlock with the arm, as shown in Figure 4. The catch 27 is pivotally mounted at 32 on a bracket 33 which connects the various parts to the casing 1. Shaft 8 at one end is supported by the casing 1 and at the opposite end by a metal bracket 34, which is connected with a wire 35, which wire extends to one terminal, namely, terminal 36 of the bell 7. The opposite terminal 37 is connected with wire 39 which is in turn connected at 40 to wire 21.

By this arrangement of parts it will be readily observed that whenever the alarm mechanism of the clock 3 starts to function or "goes off", as it is usually termed, the hammer 12 will begin to vibrate. This vibration or operation of the hammer 12 need be only once, although many times will not injure the mechanism. However, on the first blow of the hammer 12 on contact 14 current will begin to flow. It will be understood that the transformer 9 is plugged into the house current, consequently whenever the circuit is closed by the hammer 12 touching contact 14, current will flow from the transformer 9 through wire 21 to hammer 12, and from thence to the contact 14, and from contact 14 through wire 17 to one end of the winding of magnet 19, through said winding, through wire 24, and through wire 24 back to the transformer 9. As soon as the current has flowed sufficiently in this circuit to energize magnet 19 it will attract the armature of catch 27 so that the catch prong 30 will be pulled away from its position of

interlocking with arm 26, whereupon arm 26 will fall by gravity to the position shown in Figure 5.

This will close the circuit through wire 35 so that current starting from transformer 9 will pass through wire 21, wire 39, the windings of bell 7, wire 35, post 34, arm or plate 28, arm 26, connection 25 and wire 24 back to the transformer. Current will flow in this latter circuit continually until manually shut off. This will cause the bell 7 to continually sound.

When it is desired to stop the bell 7 from ringing, the thumb or finger knob is rotated and consequently the arm or plate 28 is rotated from the full line to the dotted line position shown in Figure 5, whereupon the catch 27 will interlock with arm 26. The knob is then released and plate 28 will drop by gravity to the position shown in Figure 4, whereupon the circuit through the bell will be opened and consequently the bell will stop functioning.

It is to be noted that the alarm mechanism of the clock 3 may be wound up completely, or may be only slightly wound, and in either event at a set time switch 10 will be caused to function and current turned on to the bell 7, which will continually sound the alarm until the circuit has been opened by rotation of the knob 8' and associated parts. The device will continue to function as desired until the clock 3 becomes worn out. When this occurs the owner may secure another clock and place the block 16 and other parts on the bell stem, and may then connect wire 21 either by a post similar to post 20, or by any desired means to the casing of the clock, and the device will then be ready for use with the new clock.

In this way the device will last an indefinite time and it is only necessary to provide a new clock from time to time, said clock being of the ordinary commercial variety now in use, provided with an alarm arbor and with a bell supporting stem and a hammer co-acting with the bell.

I claim—

1. In a continuous alarm, an electric switch circuit, an electric alarm circuit, a clock provided with an alarm mechanism, said mechanism being connected in series with said switch circuit whereby when said mechanism functions said switch circuit will be closed, a switch in said alarm circuit, said switch including an electro-magnet, a pivotally mounted catch acting as an armature of the magnet, a pivotally mounted arm formed with an aperture through which said catch normally extends, and a swinging stop for said arm, said stop and said arm being in series in said alarm circuit, said stop when engaging said arm acting to close said alarm circuit, an electrically operated bell operatively connected to said alarm circuit, said

bell being adapted to function when said alarm circuit is closed, said stop having a swingable plate adapted to move said arm to a position in engagement with said catch 5 whereby said alarm circuit is opened, and means for manually actuating said plate.

2. In a device of the character described, a bell, an electric alarm circuit including a source of current, to said bell and a stop, a 10 clock provided with an alarm mechanism including a stem and hammer, a gravity actuated swinging contact arm in said alarm circuit positioned in series with said bell, a catch for normally holding said arm in non- 15 functioning position, a hand-operated plate for swinging said arm to the non-functioning position, and an electro-magnet for moving said catch for releasing said arm whereby the arm may drop by gravity against said stop 20 for closing said alarm circuit, a switch circuit including a source of current, said electro-magnet and said alarm bell stem and hammer, whereby when said hammer touches said alarm bell stem, said switch circuit will be 25 closed for causing the electro-magnet to function.

PAUL V. VANDEVELDE.

30

35

40

45

50

55

60

65