



INTERNATIONAL APPLICATION PUBLISHED UNDER THE PATENT COOPERATION TREATY (PCT)

(51) International Patent Classification ⁶ : A61B	A2	(11) International Publication Number: WO 95/26673 (43) International Publication Date: 12 October 1995 (12.10.95)
(21) International Application Number: PCT/CA95/00171 (22) International Filing Date: 24 March 1995 (24.03.95) (30) Priority Data: 08/218,662 28 March 1994 (28.03.94) US (71) Applicant: XILLIX TECHNOLOGIES CORPORATION [CA/CA]; 300-13775 Commerce Parkway, Richmond, British Columbia V6V 2V4 (CA). (72) Inventors: PALCIC, Branko; 5357 Trafalgar Street, Vancouver, British Columbia V6N 1B8 (CA). MACAULAY, Calum; 5791 Prince Albert Street, Vancouver, British Columbia V5Z 3E1 (CA). LAM, Stephen; 5512 Wycliffe Road, Vancouver, British Columbia V6T 2E3 (CA). JAGGI, Bruno; 2861 West 34rd Avenue, Vancouver, British Columbia V6K 1M8 (CA). (74) Agents: CLARK, Neil, S. et al.; Smart & Biggar, 1010- 510 Burrard Street, Vancouver, British Columbia V6C 3A8 (CA).		(81) Designated States: CA, JP, European patent (AT, BE, CH, DE, DK, ES, FR, GB, GR, IE, IT, LU, MC, NL, PT, SE). Published <i>Without international search report and to be republished upon receipt of that report.</i>
(54) Title: APPARATUS AND METHOD FOR IMAGING DISEASED TISSUE USING INTEGRATED AUTOFLUORESCENCE		
(57) Abstract <p>An apparatus and method for imaging diseases in tissue are presented. The apparatus employs a light source for producing excitation light to excite the tissue to generate autofluorescence light and for producing illumination light to generate reflected and back scattered light (remittance light) from the tissue. Optical sensors are used to receive the autofluorescence light and the remittance light to collect an autofluorescence light image and a remittance light image. A filter acts to integrate the autofluorescence image over a range of wavelengths in which the autofluorescence intensity for normal tissue is substantially different from the autofluorescence intensity for diseased tissue to establish an integrated autofluorescence image of the tissue. The remittance light image provides a background image to normalize the autofluorescence image to account for image non-uniformity due to changes in distance, angle and illumination intensity. A monitor displays the integrated autofluorescence image and the remittance light image to produce a normalized image in which diseased tissue is distinguishable from normal tissue. The optical sensor can be installed adjacent the end of an endoscope probe inserted into a body cavity. A method for imaging diseased tissue using an integrated fluorescence image and a normalizing remittance image is also disclosed.</p>		

FOR THE PURPOSES OF INFORMATION ONLY

Codes used to identify States party to the PCT on the front pages of pamphlets publishing international applications under the PCT.

AT	Austria	GB	United Kingdom	MR	Mauritania
AU	Australia	GE	Georgia	MW	Malawi
BB	Barbados	GN	Guinea	NE	Niger
BE	Belgium	GR	Greece	NL	Netherlands
BF	Burkina Faso	HU	Hungary	NO	Norway
BG	Bulgaria	IE	Ireland	NZ	New Zealand
BJ	Benin	IT	Italy	PL	Poland
BR	Brazil	JP	Japan	PT	Portugal
BY	Belarus	KE	Kenya	RO	Romania
CA	Canada	KG	Kyrgystan	RU	Russian Federation
CF	Central African Republic	KP	Democratic People's Republic of Korea	SD	Sudan
CG	Congo	KR	Republic of Korea	SE	Sweden
CH	Switzerland	KZ	Kazakhstan	SI	Slovenia
CI	Côte d'Ivoire	LI	Liechtenstein	SK	Slovakia
CM	Cameroon	LU	Luxembourg	SN	Senegal
CN	China	LV	Latvia	TD	Chad
CS	Czechoslovakia	LU	Luxembourg	TG	Togo
CZ	Czech Republic	LV	Latvia	TJ	Tajikistan
DE	Germany	MC	Monaco	TT	Trinidad and Tobago
DK	Denmark	MD	Republic of Moldova	UA	Ukraine
ES	Spain	MG	Madagascar	US	United States of America
FI	Finland	ML	Mali	UZ	Uzbekistan
FR	France	MN	Mongolia	VN	Viet Nam
GA	Gabon				

APPARATUS AND METHOD FOR IMAGING DISEASED TISSUE
USING INTEGRATED AUTOFLUORESCENCE

FIELD OF THE INVENTION

5 This invention relates to an endoscope apparatus and method for viewing tissue within the body that uses autofluorescence of the tissue to detect and delineate diseased tissue.

BACKGROUND OF THE INVENTION

10 Fluorescence endoscopy involves introducing excitation light into the body and collecting the emitted fluorescence light by means of a probe that is inserted into the body to the location of interest. The probe comprises a lens fitted onto a coherent bundle of glass
15 fibres which brings the fluorescent image out of the body cavity. Alternatively, the probe can be a rigid endoscope without fibre optics. The image brought out of the body is captured by very sensitive photodetectors and further processed in an attempt to delineate diseased
20 tissue on the basis that diseased tissue has a different fluorescence intensity than normal tissue. This process loses significant amounts of light due to the image transfer through the optical fibres and a great deal of effort in developing new fluorescence endoscope systems
25 is directed toward new ways of acquiring, enhancing and analyzing the very faint fluorescence images to extract as much information as possible.

 Other work has been done in this field that attempts to exploit the different fluorescence spectra of diseased
30 and healthy tissue. United States Patents 5,131,398 to Alfano, United States Patent 4,930,516 to Alfano, and United States Patent 4,786,813 to Svanberg et al. disclose various equipment and methods that acquire and

- 2 -

process fluorescence images in an attempt to detect and delineate diseased tissue.

At present, many fluorescence endoscopy systems rely on drugs with strong fluorescence signals as well as very sensitive detectors to detect the emitted fluorescence signals. Applicant has developed equipment that employs tissue autofluorescence alone, without drugs, to detect diseased tissues such as early cancer and others. In this approach, very faint fluorescence signals must be measured at two or more specific wavelengths of emitted fluorescence. To accomplish such a measurement, very sensitive detectors, such as image intensified cameras operating at the limit of their working range must be used. This arrangement works well for detecting some tumours, but care must be taken to correctly adjust the autofluorescence signals to create appropriate images with minimal noise in order to recognize the diseased site under examination. Also, image intensified cameras (or similar detectors) are very large, they employ high voltage circuitry and they cannot be made to fit the end of the endoscope. The fluorescence images must therefore be brought out of tissue cavities through the coherent optical fibers of the endoscope before processing of the images and/or displaying them on a video monitor.

It has been suggested that the acquired fluorescence image of endoscope systems would be of better quality if it could be collected by a sensor at the end of the endoscope probe inserted into the body. The outer diameter of an endoscope probe must be small to allow insertion into various body cavities thereby limiting the size of the sensor that can be mounted at the distal end of the apparatus. As previously stated, fluorescence images are generally extremely faint and it is not possible for these small image sensors to capture the fluorescence images. Theoretically, increasing the

- 3 -

excitation irradiance would increase the fluorescence intensity, however, this may also result in unwanted thermal damage or photobleaching of the tissue under examination.

5 Prior art endoscopes have been developed that permit the image sensor to be located at the tip of the endoscope probe, however, in general, this endoscope equipment is intended for collecting reflected light and is not suitable for reliably capturing faint fluorescence
10 images.

SUMMARY OF THE INVENTION

The present invention seeks to provide an apparatus and method that addresses the problems of the prior art by providing a new system for acquiring fluorescence
15 images that uses integration of autofluorescence intensity over a broad band of wavelengths to acquire a well-defined autofluorescence image that is combined with a remittance light image to create a merged image in which diseased and normal tissue are readily
20 distinguishable. The remittance light image is used to normalize the autofluorescence image to account for image non-uniformity due to changes in distance, angle and illumination intensity.

The present invention exploits applicant's discovery
25 that in vivo tissue autofluorescence of diseased tissue is greatly reduced through a significant range of the visible light spectrum (from approximately 500nm to approximately 700nm). To exploit this natural phenomenon, the present novel system was designed and
30 developed to use the integrated fluorescence over this large spectral range (500 nm - 700 nm) and display the fluorescence image along with a remittance light image such that, to the observer, normal tissue appears in a

- 4 -

different colour from diseased tissue. In the present application, remittance light refers to reflected and back scattered light. Fluorescence signal intensity is dependent on such factors as the excitation light intensity, the proximity of the excitation light source to the tissue, and the angle of incidence of the excitation light to the tissue. To normalize for these factors, prior art systems have used two (or more) different narrow wavelength bands of fluorescence, one of which is used for normalization purposes. This requires a precondition that the difference in the tissue autofluorescence intensity between the two wavelengths must not be the same as otherwise normalization of an image could not be achieved.

In the apparatus and method of the present invention, two wavelengths of light for imaging a tissue site can be used. Preferably, blue light is used as excitation light to induce tissue autofluorescence and red/near-infrared light (approx. 700 nm) is used to produce a remittance light image. Alternatively, a single wavelength of light can be used as excitation light and a remittance light image can be collected from the remitted excitation light. The integrated autofluorescence image and the remittance light image are combined and displayed in a form to allow the observer to intuitively adjust for the excitation light intensity variations.

Accordingly, in a first embodiment, the present invention provides apparatus for imaging diseases in tissue comprising:

a light source for producing excitation light to excite the tissue to generate autofluorescence light and for producing illumination light to generate remittance light from the tissue;

- 5 -

optical means for receiving the autofluorescence light and the remittance light to collect an autofluorescence light image and a remittance light image;

5 means for integrating the autofluorescence image over a range of wavelengths in which the autofluorescence intensity for normal tissue is substantially different from the autofluorescence intensity for diseased tissue to establish an integrated autofluorescence image of the
10 tissue; and

display means for displaying the integrated autofluorescence image and the remittance light image to produce a normalized image in which diseased tissue is distinguishable from normal tissue.

15 In a further aspect the present invention provides, a method for imaging diseases in tissue comprising:

exciting the tissue to autofluoresce with excitation light to generate autofluorescence light;

20 illuminating the tissue with illumination light to generate remittance light;

detecting the autofluorescence light;

25 integrating the intensity of autofluorescence light over a range of wavelengths in which the autofluorescence intensity for normal tissue is substantially different from the autofluorescence intensity for diseased tissue to establish an integrated autofluorescence image of the tissue;

detecting the remittance light to establish a remittance light image; and

- 6 -

combining the integrated autofluorescence image and the remittance light image to produce a normalized image in which diseased tissue is distinguishable from normal tissue.

5 In a further embodiment, the present invention provides a fluorescence endoscope apparatus having an image sensing device that is positioned at the end of a probe comprised of light guides. The probe is introduced
10 into the body thereby eliminating the problem of fluorescence image degradation due to light loss while travelling through the collecting light guides. The image sensing device can be positioned adjacent to the tissue surface being examined so that there is little
15 loss of light.

15 To solve the problem of reliable and accurate acquisition of a faint fluorescence image the apparatus of the present invention employs an image sensing device such as a CCD (or equivalent such as CID) array having a sensitivity that can be varied. A preferred way to
20 achieve increased sensitivity of the CCD array is to combine individual pixel sensing elements to create larger to very large sensing units. Individual sensing elements can be combined together into 2x2, 4x4, 8x8, 16x16 or even larger groups creating new larger sensing
25 units, particularly if CCDs are used with 100% fill factor and high quantum efficiency. With special noise suppressing circuitry very sensitive detectors can be made with very low noise, i.e. very high signal-to-noise ratio (SNR), well within parameters to detect the low
30 fluorescence emitted by tissues.

Accordingly, in the further embodiment the present invention provides an endoscope apparatus for imaging a disease site within a body comprising:

- 7 -

a probe having an inner end to be located within the body near the disease site and an outer end to extend outside the body;

5 a light source at the outer end of the probe for generating light that includes excitation light to induce tissue fluorescence, the probe conveying the excitation light from the outer end to the inner end to illuminate the disease site and cause the tissue to fluoresce;

10 image sensing means at the inner end of the probe to detect tissue fluorescence, the image sensing means having a light sensitivity that can be increased to acquire low resolution images at low fluorescent light intensities and decreased to acquire high resolution images at other light intensities;

15 filtering means at the inner end of the probe for filtering out the excitation light; and

20 display means connected to the outer end of the probe for displaying the filtered image detected by the image sensing means in such a manner as to delineate diseased and normal tissue due to diseased tissue having diminished fluorescence in comparison to normal tissue.

BRIEF DESCRIPTION OF THE DRAWINGS

Aspects of the present invention are illustrated, merely by way of example, in the accompanying drawings in which:

5 Figure 1a is a graph showing a typical autofluorescence curve of light intensity over a range of wavelengths for in vivo tissue exposed to excitation light;

10 Figures 1b to 1d are graphs showing actual autofluorescence curves for tissue samples;

Figure 2 is a schematic view of a first embodiment of the present invention that employs integrated autofluorescence in which images are acquired simultaneously;

15 Figure 3 is a schematic view of a second embodiment of the present invention in which images are acquired sequentially;

20 Figure 4 is a schematic view of a third embodiment of the present invention that uses blue light to produce both the autofluorescence and remittance light images; and

Figure 5 is a schematic view of a fourth embodiment of the apparatus of the present invention that employs an CCD array positioned at the tip of an endoscopic probe.

DESCRIPTION OF THE PREFERRED EMBODIMENTS

Figure 1a shows a typical graph of the autofluorescence response spectrum of tissue in vivo when exposed to blue excitation light (400nm - 450nm).

5 Applicant has discovered that autofluorescence of diseased tissue in vivo is greatly reduced as compared to normal tissue through the entire range of visible light (from approximately 500nm to approximately 700nm). Figures 1b-1d are examples of actual autofluorescence

10 curves for tissue illuminated by blue excitation light. In Figure 1b, the autofluorescence spectrum for bronchial tissue is shown. Note that the autofluorescence intensity for normal tissue and tumorous tissue both peak in the green range of the spectrum (approximately 530nm),

15 however, the peak for tumorous tissue is much lower than the peak for normal tissue. In the region of the spectrum greater than 700nm, the spectrums for normal and tumor tissue are substantially identical. Figure 1c shows the autofluorescence spectrum for larynx tissue

20 that is induced to fluoresce using blue laser light. Again, there is a pronounced peak in the green region of the spectrum for normal tissue and a greatly reduced spectrum for tumor tissue having a low peak in the green region. In the region of the spectrum greater than 700

25 nm, the spectrum is substantially the same for both tissues. In Figure 1d, the autofluorescence spectrum for nasopharynx tissue is shown having a green region peak for normal tissue and a reduced overall spectrum for diseased tissue. While there are some differences in the

30 autofluorescence spectrum for specific types of tissue, in general, the diseased tissue autofluorescence is significantly reduced in comparison to the normal tissue autofluorescence over a broad spectral band.

Figure 2 is a schematic view of apparatus according

35 to a first embodiment that has been developed to exploit

- 10 -

the autofluorescence response of the tissue to differentiate between diseased and normal tissue. The apparatus of Figure 2 employs simultaneous illumination of the tissue with both excitation and illumination light. The apparatus includes a light source 30 for producing excitation light of a first pre-selected wavelength, preferably blue light (400-450nm), to excite the tissue to autofluoresce. The excited tissue produces a predominantly green autofluorescence light as indicated in Figures 1a-1d. Light source 30 also produces non-excitation light of a different wavelength to illuminate the tissue. The non-excitation light is preferably far red to infrared light (λ_r) including wavelengths greater than 700nm and is used to produced a remittance light image of the tissue. This non-excitation light is preferred as it falls outside the relatively broad spectral range of generally green emitted autofluorescence light ($\Delta\lambda_f$) in which autofluorescence intensity for normal tissue is substantially greater than for diseased tissue so as not to interfere with detection of the relatively faint autofluorescence image. Also, far red to infrared light has a low absorption coefficient in most tissue and it has a large scattering coefficient. Additionally, the scattering and absorption coefficients of red to infrared light do not vary much from location to location in most tissues so that red and infrared light is almost uniformly back scattered and reflected from the tissue. This remittance light is therefore relatively uniform in its angular distribution from the tissue and the intensity of light will depend almost entirely on the illumination intensity. Areas that receive less light will backscatter proportionally less in the same manner that autofluorescence emits light proportional to the amount of excitation light. Therefore, red and infrared light can be used to generate an image to correct for non-uniformity in the autofluorescence image that might

- 11 -

arise due to changes in the proximity of the excitation light to the tissue, the angle of incidence of the excitation light to the tissue and the intensity of the excitation light. It should be noted that the intensity of remittance light (λ_R) is much greater than the intensity of the autofluorescence light and a vertical break in the range over which remittance light is collected is provided in Figure 1a to account for this intensity difference.

10 The light is delivered to the tissue under examination by a conventional endoscope probe 32 comprising a bundle of optical fibres. Probe 32 also delivers autofluorescence light and remittance light from the tissue to optical means in the form of CCD cameras 34 and 36. CCD camera 36 has associated means for
15 integrating the intensity of the autofluorescence light over a range of wavelengths in which the autofluorescence intensity for normal tissue is substantially different from the autofluorescence intensity for diseased tissue
20 to establish an integrated autofluorescence intensity image of the tissue. The means for integrating the intensity of autofluorescence light preferably comprises a broad band filter 49 to admit autofluorescence light over a broad range of wavelengths. In the case of blue
25 excitation light, the resulting autofluorescence tends to be mainly green light and the intensity is integrated over the range of wavelengths from 500-650nm designated ($\Delta\lambda_f$) in Figure 1. In this manner, the need for an image intensifier is obviated as the integrated
30 autofluorescence signal is nearly an order of magnitude stronger compared to the natural autofluorescence intensity in a narrow wave band. In addition, the detected change (DC) between normal and abnormal tissue is approximately 8-10 times, compared to the 1.5 - 2
35 times of prior art systems.

- 12 -

Referring to Figure 1, the DC is defined as:

$$DC_{application} = \frac{N}{D}$$

$$DC_{priorart} = \frac{\frac{N}{D}}{\frac{n}{d}}$$

where

- 5 N = the autofluorescence intensity for normal tissue at a wavelength exhibiting the maximum difference between normal and diseased tissue
- D = the autofluorescence intensity for diseased tissue at a wavelength exhibiting the maximum difference between normal and diseased tissue
- 10 n = the autofluorescence intensity for normal tissue at a wavelength exhibiting the minimum difference between normal and diseased tissue
- d = the autofluorescence intensity for diseased tissue at a wavelength exhibiting the minimum difference between normal and diseased tissue

15 Since n/d is usually greater than 1 (in the range of 2 to 5) in prior art systems, the detected change for the apparatus and method of the present invention is generally 2 to 5 times greater than the detected change of the prior art.

20 The images captured by CCD cameras 34 and 36 are processed and displayed on display means in the form of a monitor 40. The images are preferably processed in an imaging board in a computer. The integrated autofluorescence image captured by camera 36 and the

25 remittance light image captured by camera 34 are combined to produce a normalized image in which diseased tissue is distinguishable from normal tissue. Camera 36 provides a substantially green integrated autofluorescence image that is fed to the green channel of the display and

30 camera 34 provides a substantially red remittance light

- 13 -

image to normalize the autofluorescence image that is fed to the red channel of the display to produce a normalized pseudo-colour image. If diseased tissue is present, the intensity of the green autofluorescence image will be
5 reduced over the diseased area while the remittance light image will be substantially unaffected. If tissue is normal, the intensity of the green autofluorescence image will be increased relative to the diseased tissue and the remittance light image will continue to be substantially
10 unaffected. Combining and display of the two images on monitor 40 is arranged such that the relatively constant red remittance light image is used to establish a "underlying" image that accurately displays contours in the tissue and image variations that arise due to the
15 proximity and intensity of the light source to the tissue. The mix of the images is such that normal tissue will appear green and diseased tissue will appear red due to the reduced levels of green autofluorescence in the vicinity of the diseased tissue allowing the red
20 remittance light to predominate.

The apparatus of Figure 2 is set up such that light source 30 illuminates tissue 42 with the excitation light and illumination light simultaneously and separate CCD cameras 34 and 36 are provided to receive the
25 autofluorescence image and the remittance light image. In this arrangement, light splitting means in the form of dichroic mirrors 44 and 46 are provided to direct the remittance light and the autofluorescence light to the appropriate CCD camera. While traditional 50%, 50% or
30 X%, 100-X% beam splitters may be used, dichroics increase the fluorescence image intensity available to be detected. In Figure 2, a first dichroic mirror 44 passes the red remittance light (R) to CCD camera 34 and diverts the green autofluorescence light (G) and reflected blue
35 excitation light (B) to second dichroic mirror 46. Second dichroic mirror 46 diverts the green

- 14 -

autofluorescence light (G) to CCD camera 36 and passes the blue excitation light (B).

Filter 49 in the path of the autofluorescence light is preferably adjustable to vary the range of wavelengths of autofluorescence light that are received by CCD camera 36. In this manner, the "window" over which autofluorescence is integrated can be varied to fine tune the apparatus to detect different disease conditions in different tissues that tend to exhibit characteristic autofluorescence spectra as illustrated in Figures 1b to 1d. Filter 49 can be varied by inserting an appropriate filter into place for the particular tissue and the type of tumour under examination.

In addition, an optional filter means 50 can be included in the light path to prevent blue excitation light from being received by the CCD cameras.

While the apparatus of Figure 2 employs simultaneous illumination of the tissue with both excitation and illumination light, it is also possible to expose the tissue to excitation light and illumination light sequentially. Figure 3 schematically illustrates imaging apparatus according to a second embodiment of the present invention that illuminates the tissue sequentially over a timing cycle. Light source 30 illuminates tissue 42 through endoscope 32 with excitation light for a first portion of the timing cycle. Autofluorescence light is delivered via endoscope 32 and filter 60 to a single CCD camera 62 in order to capture an integrated autofluorescence image. Filter 60 is positionable before camera 62 to filter out the excitation light and pass broadband autofluorescence light. The captured autofluorescence image is transferred to image processing means and then to image storage means located in a computer 63. Light source 30 then illuminates the tissue

- 15 -

with illumination light to generate a remittance light image. If necessary, filter 65 is moved into position to filter the remittance light. Filters 60 and 65 are mounted on a turntable arrangement 67 that is controlled
5 by computer 63. The remittance light image is transferred to the image processing and storage means. The two images collected in the timing cycle are then combined and displayed on monitor 40 in the same manner as previously described using colour to delineate normal
10 and diseased tissue. The cycle is then repeated under the control of computer 63.

The foregoing embodiments of the present invention employ blue excitation light and red illumination light to produce an image that distinguishes normal and
15 diseased tissue. In certain conditions, such as when examining inflamed tissue, the foregoing systems may cause false positive readings. In order to reduce false positive readings for cancer, a third embodiment of the present invention has been developed that employs blue
20 light as both the excitation light and the illumination light. Figure 3 is a schematic drawing of the apparatus of the third embodiment that is designed to reduce the rate of false positive readings without sacrificing true diseased tissue (true positive) detection rates.

25 False positive readings arise in inflamed tissue as the increased blood concentration tends to absorb blue excitation light and green autofluorescence light leading to a reduced autofluorescence signal. For prior art autofluorescence systems, the blood absorption causes a
30 large drop in the green autofluorescence image and a slightly less large drop in the red autofluorescence image causing the displayed image to show inflamed tissue differently from normal tissue leading to mistaken identification as diseased tissue. For the blue
35 excitation light, red illumination light imaging of the

- 16 -

present invention, the same problems occur. The integrated fluorescence drops and the red remittance image does not change significantly in areas of inflamed tissue, consequently, the displayed image does not appear
5 to show normal tissue and the inflamed area is mistaken for diseased tissue.

In the apparatus of Figure 3, light source 30 provides blue light for both excitation and illumination light in a manner identical to the embodiment of Figure
10 2. Green autofluorescence light (G) and blue remittance light (B) are collected from the tissue site. The combined light is split at dichroic mirror 44. A blue remittance light image is captured by CCD camera 34 and a green autofluorescence image is reflected through
15 integrating filter 49 for capture by CCD camera 49. In this arrangement, the intensity of the detected blue remittance light image tends to drop off almost as much as the green integrated fluorescence image, consequently, the displayed image of inflamed tissue does not differ
20 significantly from normal tissue.

An additional modification of the apparatus of the third embodiment can be used to make the presence of increased blood at a tissue site appear as a recognizable colour on the displayed image that would not be confused
25 with normal or diseased tissue. In the modified apparatus, blue excitation light and red illumination light are used and a blue remittance light image, a red remittance light image and a green integrated autofluorescence image are collected. The red and blue
30 remittance images are captured by camera 34. Camera 34 sends the red remittance image via its red channel and the blue remittance image via its blue channel to display 40. The green integrated autofluorescence image is captured by camera 36 and sent to the green channel of
35 the display. On the display, normal tissue appears

- 17 -

white, inflamed tissue has a reddish hue and abnormal tissue has a purplish hue.

The technique of the present invention also allows development of an imaging system that is sufficiently
5 small and compact to be positioned at the end of an endoscope probe. Referring to Figure 5, there is shown an endoscope system 2 for imaging a disease site within a body according to a fourth embodiment of the present invention. The apparatus includes a probe 4 having an
10 inner end 6 that is insertable into a body to be located near the disease site. The outer end of probe 4 remains outside the body for connection to a light source 8 for generating light and display means in the form of a colour monitor 10 for displaying the image collected by
15 probe 4.

Light source 8 generates light at the outer end of the probe that includes excitation light to induce tissue fluorescence. The probe is comprised of a bundle of
20 optical fibres 10 that convey the light of source 8 from the outer end to inner end 6 to illuminate the disease site. At inner end 6, there is provided image sensing means, preferably in the form of CCD sensor 12 to detect and collect an image of the diseased site using remittance light and emitted fluorescent light. CCD
25 array 12 communicates with the outer end of probe 4 via electrical connection 14 that extends through probe 4.

Preferably, inner end 6 is provided with a lens 15 to focus light on CCD sensor 12. Filtering means in the form of a filter module 16 is positioned before CCD
30 sensor 12. Filter module 16 can be fixed in place or removable remotely. Alternatively, the filtering means can be a coating applied directly to surface of CCD sensor 12. In a still further arrangement, filter module 16 can be associated with lens 15. The filter module 16

- 18 -

acts to exclude excitation light and pass light of other wavelengths to the image sensing means, particularly emitted fluorescent light.

5 The image collected by CCD sensor 12 is transmitted via line 14 to the outer end of probe 4 for viewing on display means in the form of a colour monitor 18. The image displayed on monitor 18 delineates diseased and normal tissue for viewing by the endoscope operator.

10 The endoscope apparatus of the fourth embodiment is able to collect the faint fluorescence images that provide information necessary for delineating diseased and normal tissue by virtue of the fact that CCD sensor 12 is provided with a light sensitivity that can be increased to acquire low resolution images at low
15 fluorescent light intensities and decreased to acquire high resolution images at other light intensities.

The light sensitivity of CCD sensor 12 is adjusted by binning the pixels of the sensor array. Binning the pixels decreases spatial resolution. For example, a CCD
20 sensor comprised of 250x250, (i.e. 62,500 active pixels) if binned to form 8x8 pixels per each new sensor unit would yield an effective CCD of approximately 30x30 pixels (each pixel being 64 times larger than the original pixels) providing a very low resolution image.
25 However, dynamic binning can solve the problem of the low spatial resolution as will be described below.

In operation, light source 8 can provide a broad spectral band of excitation light ranging in wavelength between 400-480nm (broad band blue light). Such an
30 excitation light tends to generate a strong fluorescence response in most tissues such as the lungs, the esophagus, the colon, the bladder and the skin. The peak fluorescence is in the green region at approximately

- 19 -

510nm and it has been shown that the fluorescence signal is greatly diminished or virtually disappears in abnormal tissue due to early cancer or dysplasia. Alternatively, the excitation light can be in a narrow spectral band of blue or violet light.

The blue excitation light of light source 8 is conveyed to inner probe end 6 to illuminate an internal disease site to induce maximum tissue fluorescence particularly in the green and longer wavelengths.

10 Scattered/reflected excitation light and fluorescence light are focused by lens 15 on CCD sensor through filter module 16. Filter module 16 is selected to filter out the blue band excitation light such that only the fluorescence green and longer wavelengths (e.g. greater than 480nm) are collected by the CCD sensor. Since abnormal tissue has greatly diminished (or a lack of) fluorescence particularly in the green region, the abnormal tissue will be detected as a darker area on the image captured by the CCD sensor. The darker abnormal regions of tissue will be readily apparent on display monitor 18. The light sensitivity of the CCD sensor can be increased by binning to acquire low resolution images at low fluorescent light intensities. While the images are of reduced resolution, they are generally sufficiently detailed to accurately determine the extent and location of the diseased tissue.

The arrangement of the fourth embodiment of the present invention reduces the complexity of the apparatus as there is generally no longer the need for an image intensifier to enhance the image collected by the CCD sensor since the sensor is located immediately adjacent the image site and the binning of the CCD sensor permits acquisition of very faint fluorescence images albeit at reduced resolution.

- 20 -

In a variation of the fourth embodiment, high resolution non-fluorescence images and low resolution fluorescence images of the disease site can be acquired sequentially and combined for display on monitor 18. In this variation, the endoscope apparatus is identical to the fourth embodiment except light source 8 is modified to sequentially illuminate the disease site with two or more wavelengths of light over a timing cycle. One wavelength is a fluorescence excitation light that is on for the majority of the timing cycle and the other wavelength is a non-excitation light that is on for a short period of the timing cycle. This arrangement requires means to increase the image sensing means sensitivity to acquire a low resolution fluorescence image during illumination by the fluorescence excitation light and decrease the image sensing means sensitivity to acquire a high resolution image during illumination by the non-excitation light. This arrangement also requires image processing means for storing sequential images captured by the image sensing means and combining the images for display as a pseudo-colour image on the display means.

Preferably, the endoscope apparatus of the present embodiment is operated in the following manner:

Light source 8 sequentially illuminates the disease site briefly through probe 6 with red non-excitation light and blue fluorescence excitation light over a single cycle of 30msec which is consistent with video display rates. The scattered and/or reflected red light is passed through filter module 16 in front of the CCD sensor 12. The red light is sufficiently intense that CCD sensor 12 does not have to be binned and an image of the site at high resolution is captured by the sensor. The illumination with red light is of short duration (e.g. 5msec pulse) and the image is stored in a buffer of

- 21 -

the image processing means comprising an imaging board
20. The blue light is of much longer duration (e.g.25
msec) to collect sufficient fluorescence light generated
by the blue light. In addition, the CCD is now binned if
5 necessary to detect and capture the fluorescence image of
the site at reduced resolution. Filter module 16
excludes the blue excitation light and permits passage of
green and longer wavelengths. The captured fluorescence
image is fed into another buffer of the imaging board. A
10 pseudo image is then formed by the imaging board for
display on RGB monitor 18. The pseudo image is a
composite image that includes a very high resolution
colour image (generated using the red light) superimposed
on a green to dark green lower resolution image
15 (generated using the blue light). In the composite
image, normal tissue will be green and diseased or
abnormal tissue will show up as red or pink areas. This
combination of fluorescence and reflectance imaging has
the additional advantage of compensating for changes in
20 fluorescence intensity due to variation in the distance
and angle between the probe and the surface of the body
cavity.

Although the present invention has been described in
some detail by way of example for purposes of clarity and
25 understanding, it will be apparent that certain changes
and modifications may be practised within the scope of
the appended claims.

- 22 -

WE claim:

1. Apparatus for imaging diseases in tissue comprising:

5 a light source for producing excitation light to excite the tissue to generate autofluorescence light and for producing illumination light to generate remittance light from the tissue;

10 optical means for receiving the autofluorescence light and the remittance light to collect an autofluorescence light image and a remittance light image;

15 means for integrating the autofluorescence image over a range of wavelengths in which the autofluorescence intensity for normal tissue is substantially different from the autofluorescence intensity for diseased tissue to establish an integrated autofluorescence image of the tissue; and

20 display means for displaying the integrated autofluorescence image and the remittance light image to produce a normalized image in which diseased tissue is distinguishable from normal tissue.

2. Apparatus as claimed in claim 1 in which the excitation light is blue light including wavelengths in the range of 400nm - 450nm.

25 3. Apparatus as claimed in claim 1 in which illumination light is red to near infrared light including wavelengths greater than 700nm.

4. Apparatus as claimed in claim 1 in which the illumination light is the same as the excitation light.

- 23 -

5. Apparatus as claimed in claim 1 in which the autofluorescence intensity is integrated over the range of wavelengths from 500-700nm.

6. Apparatus as claimed in claim 1 in which the light source illuminates the tissue with the excitation light and illumination light simultaneously.

7. Apparatus as claimed in claim 6 in which the optical means comprises a pair of CCD cameras, one camera receiving the autofluorescence image and the other camera receiving the remittance light image.

8. Apparatus as claimed in claim 7 including light splitting means for directing the remittance light to one CCD camera and the autofluorescence light to the other camera.

9. Apparatus as claimed in claim 8 in which the light splitting means comprise a first dichroic mirror to divert the remittance light to one CCD camera and pass the autofluorescence light and excitation light to a second dichroic mirror, the second dichroic mirror diverting the autofluorescence light to the other CCD camera and passing the excitation light.

10. Apparatus as claimed in claim 1 in which the means for integrating the autofluorescence image comprise an adjustable filter to vary the wavelengths of autofluorescence light that are received by the optical means.

11. Apparatus as claimed in claim 1 including filter means for preventing excitation light from being received by the optical means.

- 24 -

12. Apparatus as claimed in claim 1 in which the light source illuminates the tissue with excitation light and illumination light sequentially over a timing cycle.

13. Apparatus as claimed in claim 12 including
5 image storage means for storing sequential images captured by the optical means, the stored sequential images being combined and displayed on the display means.

14. Apparatus as claimed in claim 1 in which the
10 display means comprises a colour monitor having green and red signal channels, the integrated autofluorescence image being fed to the green channel of the monitor and the remittance light image being fed to the red channel to produce a normalized pseudo-colour image in which
15 diseased tissue appears red and normal tissue appears green.

15. Apparatus as claimed in claim 4 in which the display means comprises a colour monitor having green and blue signal channels, the integrated autofluorescence image being fed to the green channel of the monitor and
20 the remittance light image being fed to the red channel to produce a normalized pseudo-colour image in which diseased tissue appears blue and normal tissue appears green.

16. Apparatus as claimed in claim 1 including
25 optical means for receiving reflected excitation light to collect an excitation light image.

17. Apparatus as claimed in claim 16 in which the display means comprises a colour monitor having red, green and blue signal channels, the integrated
30 autofluorescence image being fed to the green channel of the monitor, the remittance light image being fed to the red channel and the excitation light image being fed to

- 25 -

the blue channel to produce a normalized pseudo-colour image in which normal tissue appears white, inflamed tissue has a reddish hue and diseased tissue has a purplish hue.

5 18. Apparatus as claimed in claim 1 including an optical probe having an inner end for insertion within a body and an outer end to extend outside the body for transmitting light to and from the tissue under examination.

10 19. Apparatus as claimed in claim 18 in which the optical means is positioned proximal the inner end of the optical probe.

 20. Apparatus as claimed in claim 19 in which the optical means comprise a CCD array.

15 21. A method for imaging diseases in tissue comprising:

 exciting the tissue to autofluoresce with excitation light to generate autofluorescence light;

20 illuminating the tissue with illumination light to generate remittance light;

 detecting the autofluorescence light;

 integrating the intensity of autofluorescence light over a range of wavelengths in which the autofluorescence intensity for normal tissue is substantially different
25 from the autofluorescence intensity for diseased tissue to establish an integrated autofluorescence image of the tissue;

- 26 -

detecting the remittance light to establish a remittance light image; and

combining the integrated autofluorescence image and the remittance light image to produce a normalized image
5 in which diseased tissue is distinguishable from normal tissue.

22. A method as claimed in claim 21 in which the excitation light is blue light (400nm - 450nm)

23. A method as claimed in claim 21 in which the
10 illumination light is far red to infrared light including wavelengths greater than 700nm.

24. A method as claimed in claim 21 in which the illumination light is the same as the excitation light.

25. A method as claimed in claim 21 in which the
15 autofluorescence intensity is integrated over the range of wavelengths from 500-700nm.

26. A method as claimed in claim 21 in which the steps of exciting the tissue and illuminating the tissue with illumination light are carried out simultaneously.

20 27. A method as claimed in claim 21 in which the steps of exciting the tissue and illuminating the tissue with illumination light are carried out sequentially.

28. A method as claimed in claim 21 in which the remittance light image is detected at wavelengths in
25 which the autofluorescence intensity for normal tissue is substantially similar to the autofluorescence intensity for diseased tissue to establish a remittance light image of the tissue.

- 27 -

29. Endoscope apparatus for imaging a disease site within a body comprising:

5 a probe having an inner end to be located within the body near the disease site and an outer end to extend outside the body;

10 a light source at the outer end of the probe for generating light that includes excitation light to induce tissue fluorescence, the probe conveying the excitation light from the outer end to the inner end to illuminate the disease site and cause the tissue to fluoresce;

15 image sensing means at the inner end of the probe to detect tissue fluorescence, the image sensing means having a light sensitivity that can be increased to acquire low resolution images at low fluorescent light intensities and decreased to acquire high resolution images at other light intensities;

filtering means at the inner end of the probe for filtering out the excitation light; and

20 display means connected to the outer end of the probe for displaying the filtered image detected by the image sensing means in such a manner as to delineate diseased and normal tissue due to diseased tissue having diminished fluorescence in comparison to normal tissue.

25 30. Endoscope apparatus as claimed in claim 29 in which the image sensing means is a CCD.

31. Endoscope apparatus as claimed in claim 23 in which the light sensitivity of the image sensing means is increased by binning pixels of the CCD array.

- 28 -

32. Endoscope apparatus as claimed in claim 30 in which the filtering means comprises a coating on the CCD array.

33. Endoscope apparatus as claimed in claim 29
5 including a lens at the inner end of the probe to focus fluorescence light on the image sensing means.

34. Endoscope apparatus as claimed in claim 29 in which the light source generates excitation light in a broad spectral band ranging from 400nm to 480nm.

10 35. Endoscope apparatus as claimed in claim 29 in which the light source generates excitation light in a narrow spectral band of blue or violet light.

36. Endoscope apparatus as claimed in claim 29 in which the filtering means comprises a long pass blue
15 filter positioned before the image sensing means.

37. Endoscope apparatus as claimed in claim 29 in which the filtering means excludes excitation light and passes light of other wavelengths to the image sensing means.

20 38. Endoscope apparatus as claimed in claim 37 in which the filtering means excludes blue excitation light and passes green and longer wavelength light.

39. Endoscope apparatus as claimed in claim 37 in which the light source sequentially illuminates the
25 disease site with two or more wavelengths of light over a timing cycle, one wavelength being an excitation light and the other wavelengths being non-excitation light, and including means to increase the image sensing means sensitivity to acquire a low resolution fluorescence
30 image during illumination by the excitation light and

- 29 -

decrease the image sensing means sensitivity to acquire a high resolution reflectance image during illumination by the non-excitation light.

40. Endoscope apparatus as claimed in claim 39 in
5 which the excitation light is on for the majority of the timing cycle and the non-excitation light is on for the remainder of the timing cycle.

41. Endoscope apparatus as claimed in claim 39
including image processing means for storing sequential
10 images captured by the image sensing means and combining the fluorescence and reflectance images for display as a pseudo-colour image on the display means.

42. Endoscope apparatus as claimed in claim 39 in
15 which the light source illuminates the disease site with red non-excitation light and blue excitation light.

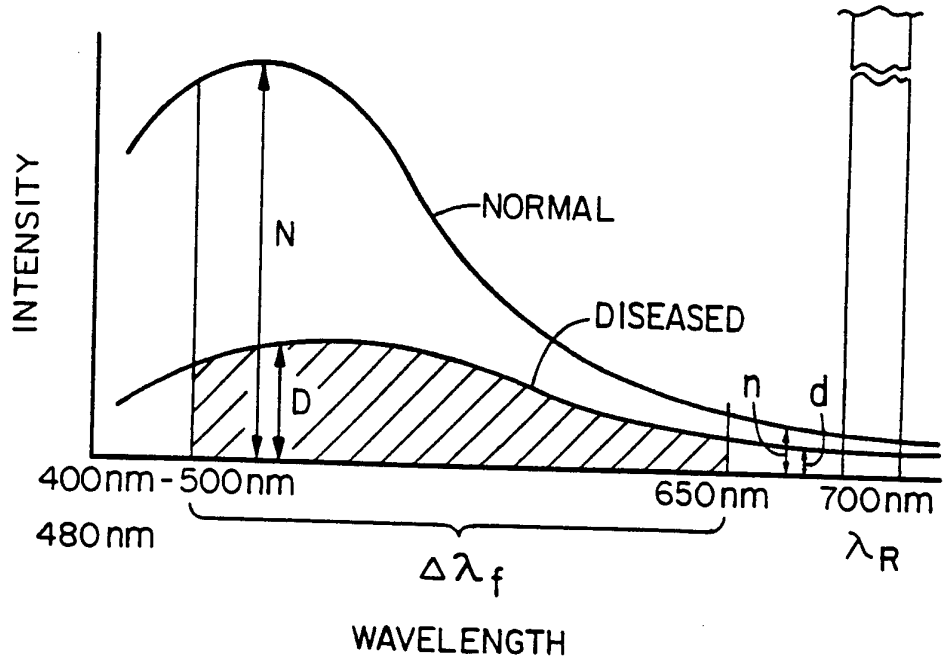

FIG. 1a

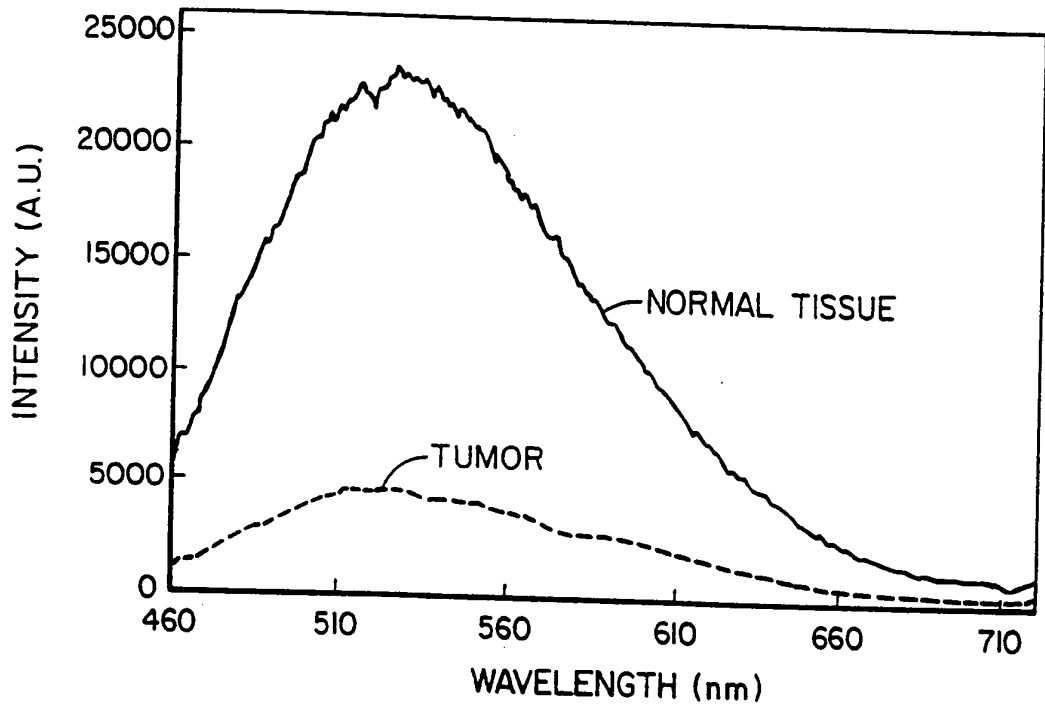

FIG. 1b

2/6

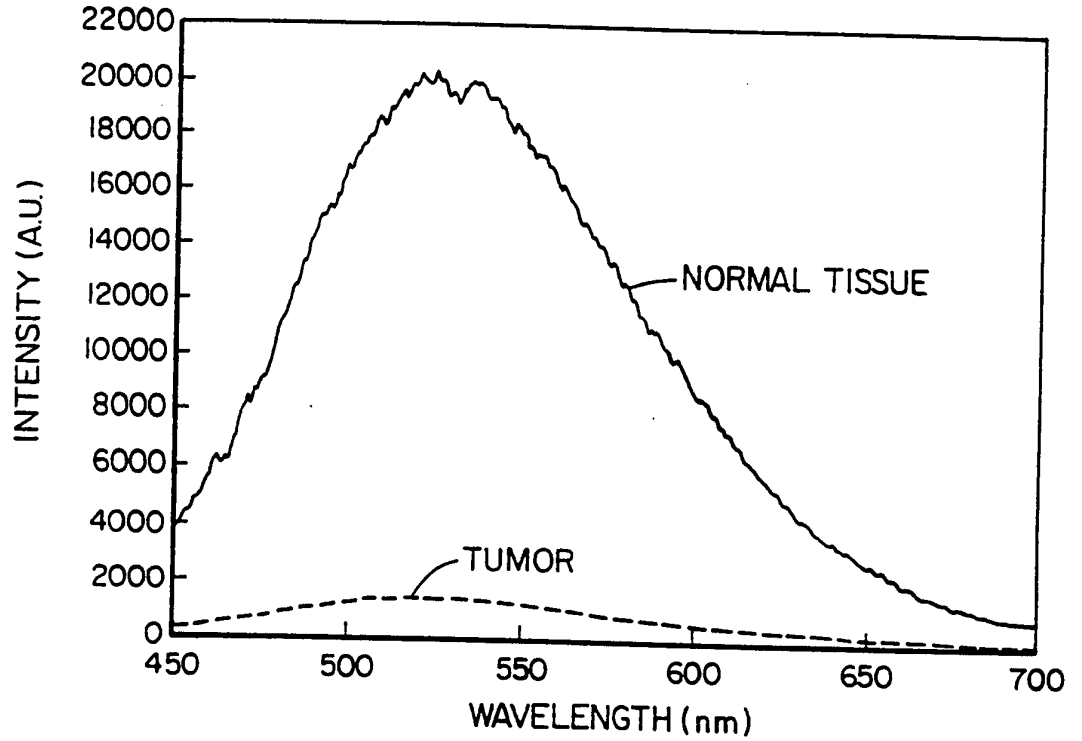

FIG. 1c

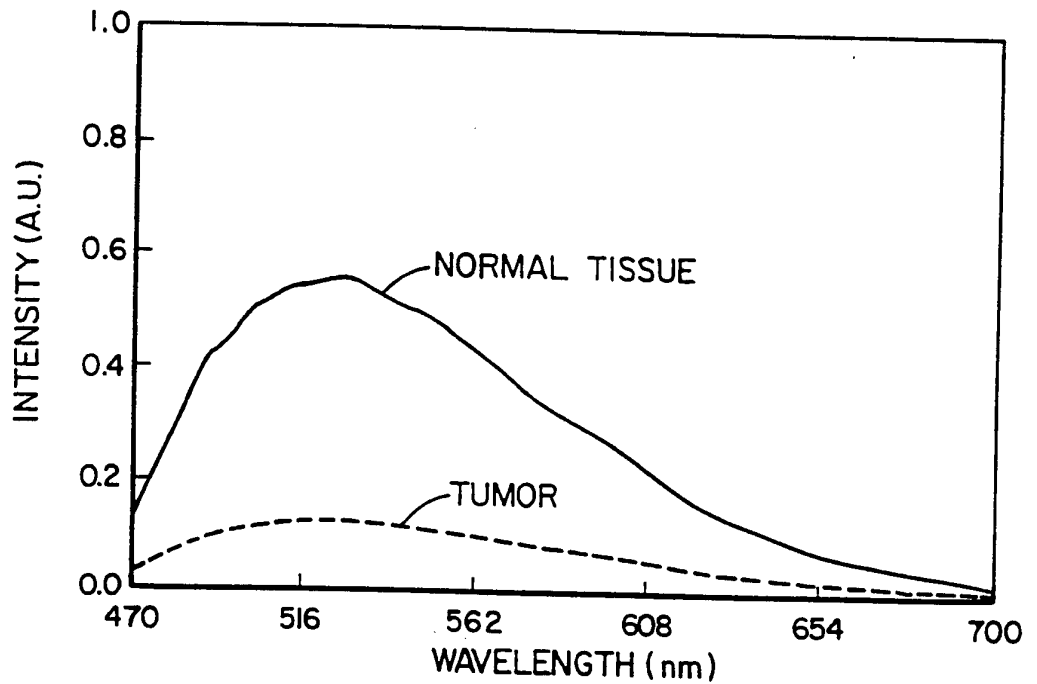

FIG. 1d

3/6

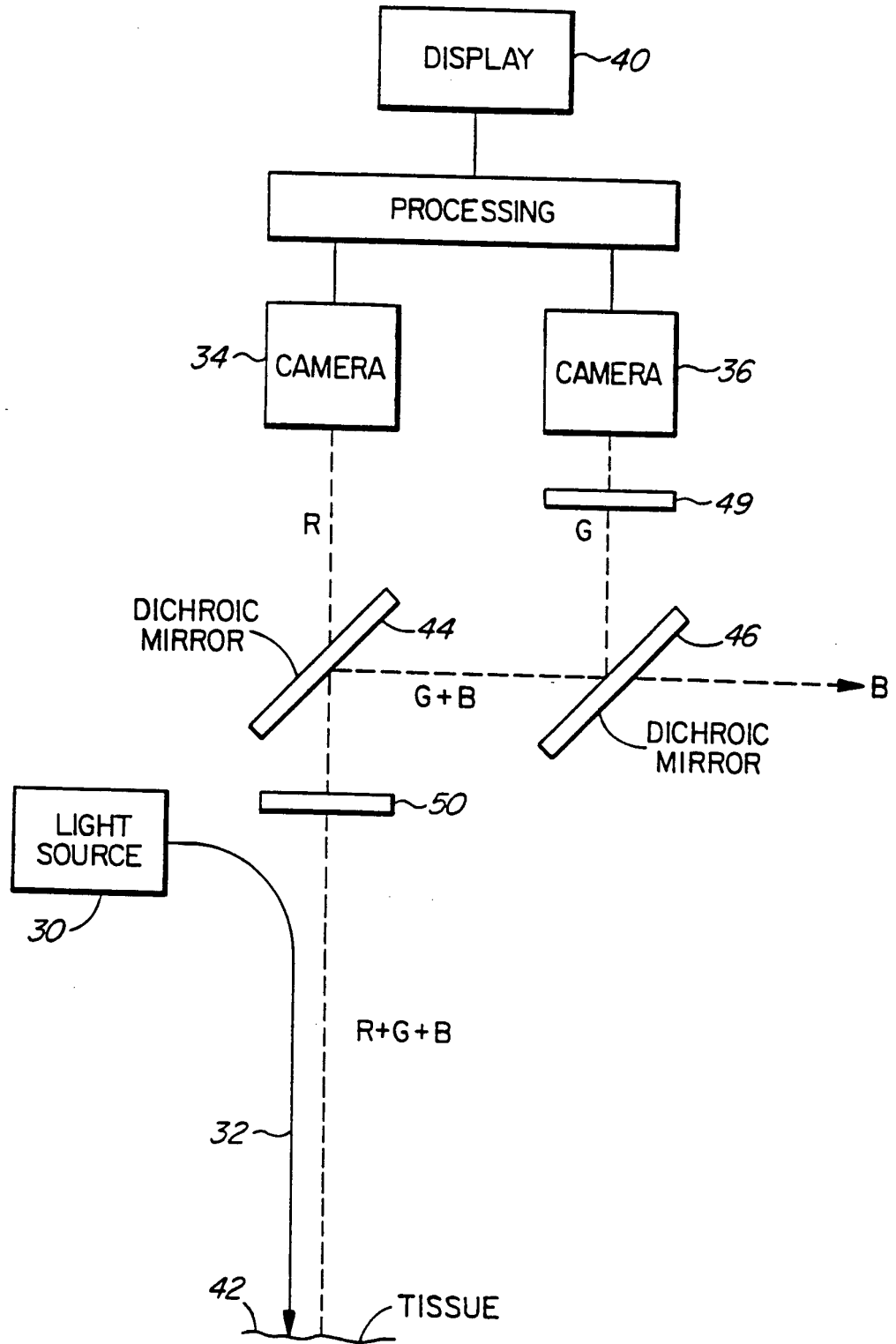

FIG. 2

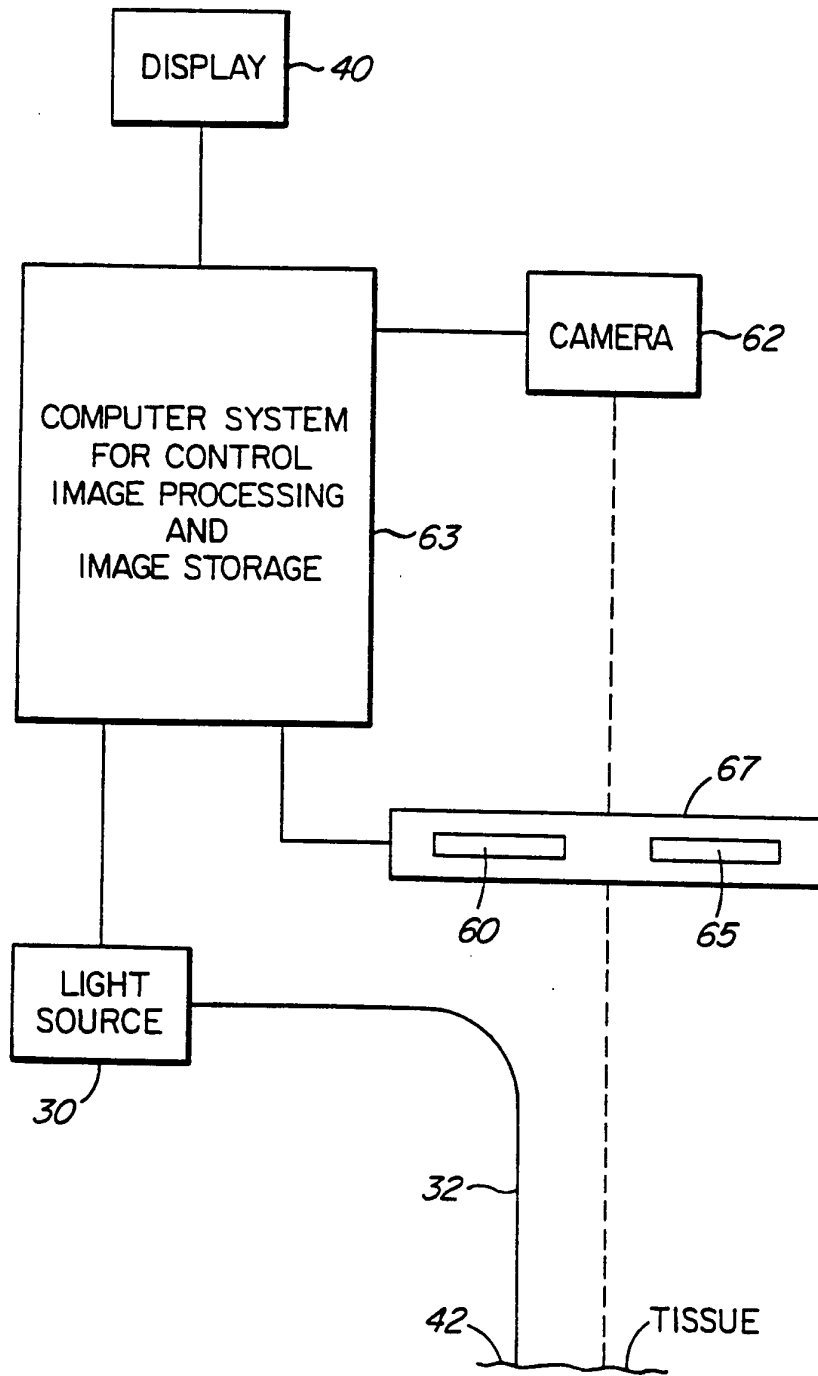

FIG. 4

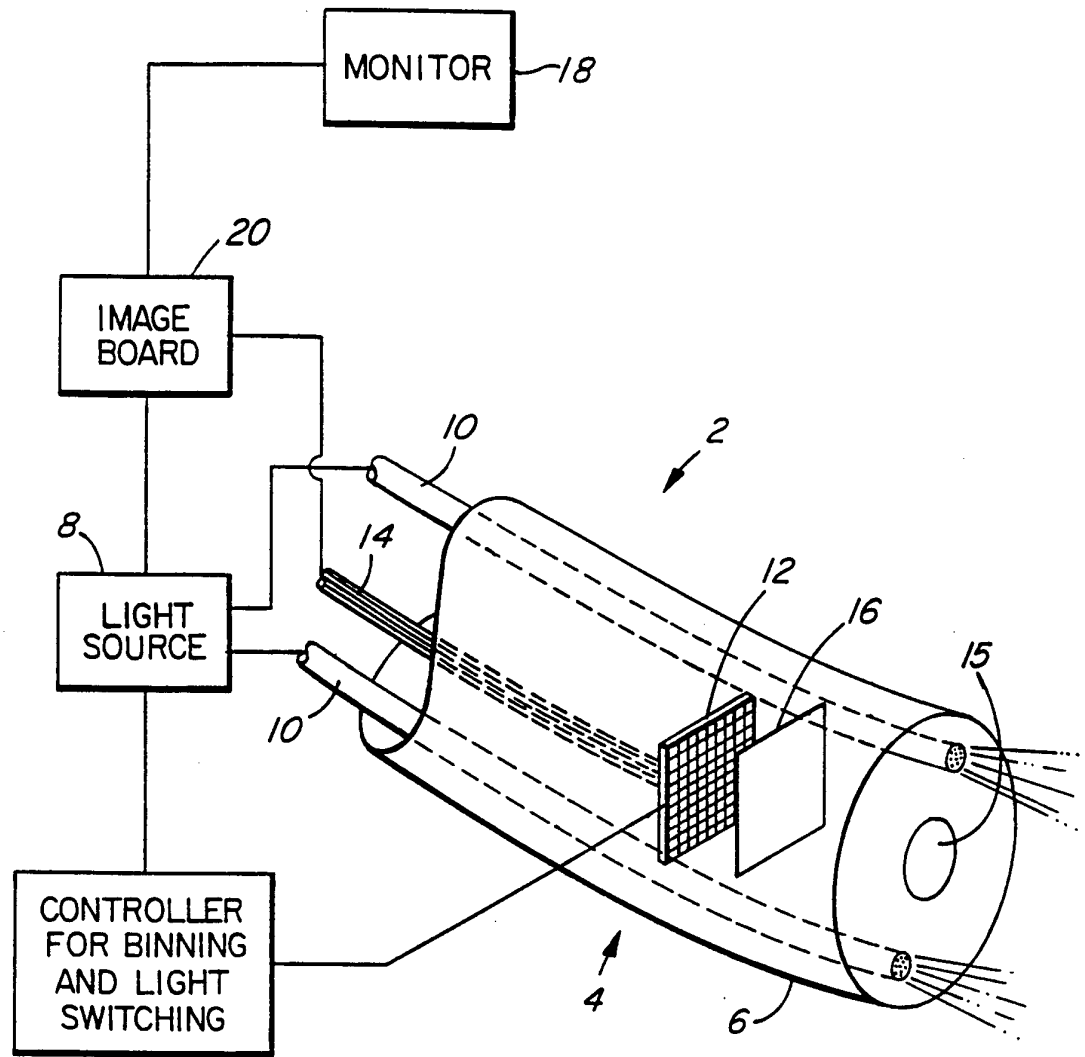

FIG. 5