

Aug. 8, 1961

E. P. MAIDMENT

2,995,366

DOCUMENT ARRESTING MEANS

Filed March 17, 1958

Fig. 1.

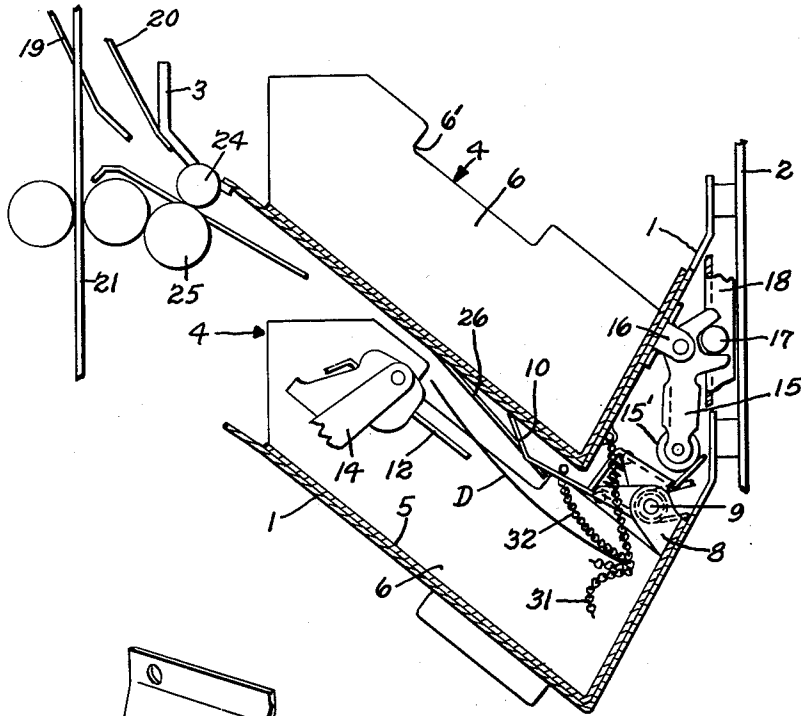

Fig. 2.

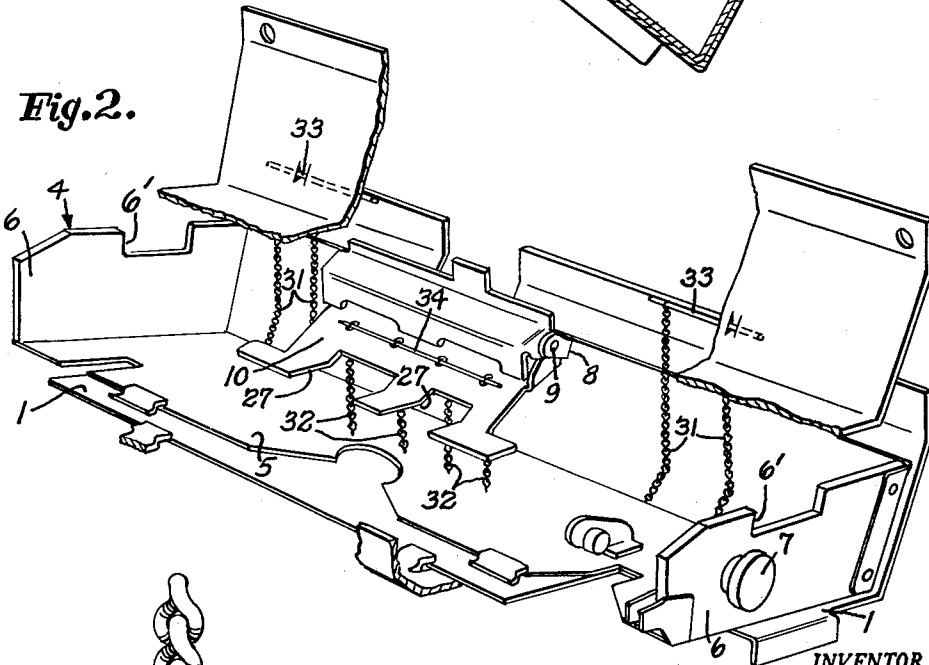

Fig. 3.



INVENTOR.  
EARL P. MAIDMENT  
BY  
Fidler, Crouse & Beardsley  
ATTORNEYS

1

2,995,366

**DOCUMENT ARRESTING MEANS**

Earl P. Maidment, Royal Oak, Mich., assignor to Burroughs Corporation, Detroit, Mich., a corporation of Michigan

Filed Mar. 17, 1958, Ser. No. 722,065

10 Claims. (Cl. 271—86)

This invention relates to document quieting means for use in document sorting machines and the like in which, for example, bank checks are rapidly conveyed to and collected in one or more bins or the like.

In such a machine, the documents pass through a high speed conveying means, in which they may be carried by rapidly driven rubber or composition belts, and thus acquire a considerable momentum which, as the documents arrive in a collecting bin would cause the documents to rebound from wall to wall of the bin or from the stack of previously collected documents in the bin. In its rapid passage through the conveyor and rapid projection into the collecting bin, a document may also acquire a considerable static electric charge which, if not removed or counteracted, may also greatly hinder the desired settling of the document to the bottom of the bin or on top of a stack of previously collected documents in the bin, and may cause a document to become caught in or to fly out through a small opening such as formed by the clearance between the top edge of a document collecting tray in the bin and the wall of the bin itself. A static electric charge may cause the document to adhere to a wall of the bin for a considerable time.

It is of considerable importance to secure prompt quieting and quick settling of the documents in the collecting bins both to permit collection and compact stacking of a maximum number of documents in a bin, to cause the collected documents to be stacked in the same order in which they are delivered to a bin, and to prevent misplacement and loss of documents or damage to them.

It is, therefore, an object of the present invention to provide a simple means for promptly and effectively quieting documents as they are delivered into collecting trays, bins or compartments, particularly in machines of the kind above specified.

Another object is to provide a simple means for braking a document delivered at high speed, quickly and without damage to the document.

A further object is to provide a simple means for quickly drawing both kinetic energy and static electric charge from a document delivered at high speed into a collecting tray, bin, compartment or enclosure.

The foregoing and other objects and advantages of the invention will become apparent from the following description with reference to the accompanying drawings in which:

FIG. 1 is a vertical section through a portion of a document sorting machine equipped with the present invention;

FIG. 2 is a perspective view of a portion of a document collecting bin of such machine and of a document tray in the bin; and

FIG. 3 is a detail of a portion of a document quieting element.

The machine chosen for disclosure of a practical embodiment of the invention has document collecting bins arranged in columns, each bin in a column being provided between adjacent formed sheet metal plates 1 suitably secured to or supported on metal frame elements, such as 2 or other stationary metal members, such as 3, of the machine which are grounded to the metal frame of the machine. Each bin contains a removable document tray 4 which is open at the top and front and comprises a sheet metal plate 5 bent to form the bottom and

2

rear walls of the tray, and further comprises right and left side walls 6. The side walls 6 are preferably formed from clear, transparent plastic and are secured at their bottom and rear edges to the side edges of the plate 5. The upper edges of the side walls are notched as shown at 6' to clear projections on fixed members (not shown) of the machine which, with the walls 6 of the trays, close the sides of the bins except for the small clearance provided between said fixed members and the walls 6. One or both the side walls 6 may be provided on the outer side with a knob 7 to facilitate manual removal of the tray laterally from its bin.

Ears 8 struck out of the rear wall portion of the plate 5 carry a metal rod 9 which pivotally supports a packer bail 10 which formed of metal and is spring-urged counterclockwise in FIGS. 1 and 2 toward a normal position shown in FIG. 2 where its forward portion is lowered to bear against a stack of accumulated documents in the tray. An auxiliary bail 12 (FIG. 1) is normally in a position forwardly and clear of the tray 4 on arms 14 pivotally supported on fixed portions of the machine. In each operation of the machine in which a document is to be delivered to a bin thereof, the bail 12 for that bin is swung rearwardly and downwardly against the top of the accumulated stack of documents in the tray 4 in that bin (by means not shown herein) and the bail 10 is then swung upwardly clear of the stack of documents to the position shown in FIG. 1 by metal roller 15' carried by a metal lever 15 which is pivoted on a metal bracket 16 conductively secured to the rear wall portion of the next higher plate 1 and is operated by a stud 17 on a vertically movable link 18. As is readily apparent, the bail 10 is electrically conductive and is electrically grounded to the machine frame which, in turn, may be and preferably is grounded by a grounding conductor (not shown). As the auxiliary bail 12 is swung to active position, a conveyor switch or deflector, parts of which are shown at 19 and 20 in FIG. 1, are also shifted to position as indicated in FIG. 1 to direct a conveyed document from the conveyor belts 21 into the bin entrance between a guide plate 22 and the next higher members 1 and 3. When the document reaches the bin entrance, it is positively and rapidly fed therethrough by driven rollers 24 and 25 and projected over the depressed bail 12 and under the elevated bail 10. Fingers 26 struck out of the plates 1 are inclined rearwardly and downwardly to guide the incoming documents past the forward edge of the bail 10 which is notched as at 27 to clear the ends of the fingers 26.

After the document has been delivered to the selected bin, the bail 10 is lowered upon it and the bail 12 is restored to normal position clear of the tray.

To secure maximum productiveness, the machine is operated at high speed. The documents are conveyed to and projected into the bins at high velocity and the machine and its components are returned to normal in readiness for the next operation with a minimum of delay. Among other things, the bails 10 and 12 are restored to normal as rapidly as is consistent with proper operation and it is, therefore, important that documents delivered to the bins be quieted and settled on top of the stacks of previously accumulated documents as rapidly as possible. Rebounding of a delivered document which might carry it forwardly over the bail 12 or even into the bin entrance again, and fluttering and skittering which might carry the document laterally over the side wall 6 of the tray and might cause the document to become wedged against the top edge of the side wall, are to be prevented to avoid damage to and possible loss of documents as well as for permitting compact, orderly stacking of the documents and the most rapid operation of the machine.

For the above purposes, the present invention provides, in each sorted document bin of the machine, document quieting means comprising a plurality of document decelerating and quieting elements 31 and 32, each comprising a length of light weight, flexible, metallic linked structure of the general character of jeweler's chains. The chains 31 in FIGS. 1 and 2 are suspended from a thin, electrically conductive, metal rod or wire 33 which is passed through the topmost link of each length of chain and through loops struck out of the rear wall portion of the next higher plate 1 to which the chains 31 are thus conductively connected. The upper end links of the chain lengths 32 are passed upwardly through apertures in the bail 10 and secured by a thin, electrically conductive, metal rod or wire 34 which passes through those links above the bail 10 and bears against the upper surface of the latter whereby the chains 32 are conductively connected to the bail 10. Each time the bail 10 is elevated preparatory to the delivery of another document, the chains 32 are suspended through the path in which the document will move across the bin. The lengths of the chains are preferably such that the stationarily supported chains 31 just reach the bottom of the angle in the plate 5 and the chains 32 suspended from the bail 10 almost reach to the plate 5 when the bail 10 is in the elevated position shown in FIG. 1.

As shown in FIG. 1, a document D, such as a bank check, for example, strikes edgewise against the suspended lengths of chains 31 and 32. The inertia with which the chain resists initial movement immediately it is struck by the rapidly moving check is quite small as only a few links of the chain are directly moved by the document and with the same high velocity as the document, but during the continuing movement as more and more of the chain is moved, the inertial resistance builds up rapidly in relation to the decelerating document so that the movement of the latter rearwardly in the bin is quickly stopped without damage to the engaged edge of the document. As the chains are electrically conductive and are grounded on the metal frame of the machine, they appear also to quickly drain from the documents any substantial static electric charges which the documents may have accumulated in their rapid movement through the conveyor of the machine and into the bins. The action of the chains in draining and grounding static electric charges from the documents to the machine frame can be especially important where, as is preferred, the undersides of the forward fingers of the packer bail 10 are coated with a rubber, latex or other substantially non-conducting, cushioning material to minimize any risk of damage to documents by the bail. In any case, the chains not only quickly but gently stop the incoming documents but they also bring about a rapid quieting and settling of an incoming document upon the top of the stack of documents previously collected in the tray.

Considerable variation in the specifications of the chains is permissible. However, to avoid damage to the leading edge of the incoming document by keeping small the inertial resistance to initial movement of the impacted portion of the chain at the instant of impact, the chains should be of relatively light weight per unit of length and the length of link should also be relatively small. For use with documents of the size and weight of bank checks, chains having a weight of about one-seventh of a gram per inch of length have been found most satisfactory. More particularly a chain of standard size 1824C has been found best, such chain having 24 links per inch formed of wire having a diameter of 0.018 inch. The links of that chain are 0.075 inch long and 0.062 inch wide and the chain weights 0.138 gram per inch. In that situation, the chains 32 were of one and five-eighths inch length and the chains 31 were somewhat longer. The lengths of the chains 31 is partly determined by the height of their points of suspension above the floor of the tray 4 into which they hang and a considerable part of

their length may, as in the illustrated embodiment, be above the region where they may engage the incoming documents.

Various styles and designs of chains or very flexible chain-like articles formed of a considerable number of relatively small links or elements serially connected in a manner permitting free swinging relative movement between adjacent elements may be used, but no portion of the chain elements or links exposed to being struck by the edge of a rapidly moving document should be so thin as to permit the edge of said document to be cut or notched thereby and snagged on it. A specific form of the above-mentioned 1824C chain which has been used very satisfactorily is, as shown on a magnified scale in FIG. 3, of a flattened or curb type having twisted links. The chains may be made of various kinds of electrically conducting material or metal but for satisfactory wearing quality they should be formed of hard metal or have a hard metal surface. The particular 1824C chain mentioned above had its links made from solid brass rod, hot nickel undrecoated and plated with rhodium.

Not only may the link dimensions and weight vary somewhat for a given range of size and weight of document but should preferably be varied with the weight of the documents to be handled. Chain length may also be varied as document size and weight and bin dimensions are varied so as to permit the chains to intercept the incoming documents and provide the required capacity to drain the kinetic energy from them.

Also the number of suspended lengths of chain may be varied and the relative numbers of chain lengths suspended from stationary members as in the case of the chains 31, and chain lengths suspended from movable members, as in the case of the chains 32 suspended from the bail 10, may be varied. Very successful operation has been obtained with bank checks by using seven one and five-eighths inch lengths 32 of the above described chain No. 1824C suspended in the manner above described from the packer bail 10 without any chain lengths 31 suspended from stationary means. It appears desirable to distribute the chains across the major portion of the width of the tray to obtain the best stacking of documents of sizes varying through a substantial range as in the case of bank checks. The use of a substantial number of chains spaced apart across the width of path in which the documents are projected into the bin also secures the result that, on the average, the wider and, therefore, usually heavier documents will engage a larger number of chains of greater total weight than the narrower and usually lighter documents so that the decelerating and quieting action of the engaged chains upon the document is, to a substantial extent, automatically adjusted to the varying widths and weights of the documents being handled. Bank checks, for example, are nearly always made of a paper stock in a quite small range of variation of weight per unit of area, so that there is enough correlation of weight to width to produce the above mentioned result in a quite useful degree. In any event, a substantial number of chains of the character described spaced laterally across the width of the path of the documents has been found highly satisfactory in the handling of non-folded bank checks of the usual range of sizes.

It will easily be apparent that the present invention is readily applicable to other machines, devices or apparatus for handling light sheet or card-like articles for the purpose of quickly arresting and quieting them without damage as they are successively received at a place of collection to which they are delivered at high speed. Accordingly, in this specification and in the claims appended hereto, the word document is to be understood to include not merely papers bearing information but as also including physically similar light articles in the form of thin sheets or cards, usually but not necessarily formed of paper or paper substitutes, and fragile. Although, in the herein illustrated and particularly described preferred embodiment, the

5

invention is applied to a document sorting machine, it will readily be apparent that the invention may also be applied to other machines, devices or apparatus in which it is necessary to quickly arrest and quiet light, sheet form articles as they arrive successively in a collecting means such as a receptacle, bin, compartment or tray. The word bin as used herein for brevity, is therefore to be understood as including any collecting space provided in such machines, devices or apparatus to which such articles are delivered and collected. In the appended claims, the phrase "apparatus of the character specified" is to be understood as including any machine, apparatus or device for handling such articles and in which such articles are delivered at high speed to and collected in at least one bin as defined above.

I claim:

1. In an apparatus of the character specified, having at least one document collecting bin and means for delivering a document into said bin at high speed in a path traversing said bin above its bottom, means in said bin for arresting the movement of a document along said path comprising a plurality of light, flexible members in said bin each suspended by an end to hang transversely through said path, in position to be engaged by the leading edge of a document being delivered in said path and to thereby arrest the movement thereof, each said member being formed of a series of small, light, serially swingably connected elements.

2. In an apparatus of the character specified, having at least one document collecting bin and means for delivering a document into said bin at high speed in a path traversing said bin above its bottom, means in said bin for arresting the movement of a document along said path comprising a plurality of light, flexible members in said bin, spaced laterally across said path and each suspended by an end to hang transversely through said path in position to be engaged by the leading edge of a document being delivered in said path and to thereby arrest the movement thereof, each said member being formed of a series of small, light, serially swingably connected elements.

3. In an apparatus of the character specified, having at least one document collecting bin, means for delivering a document into said bin at high speed in a path traversing said bin above its bottom, and an electrically conductive and grounded member above a terminal portion of said path, means in said bin for arresting the movement of a document along said path comprising a plurality of light, flexible members in said bin each suspended by an end from said grounded member to hang transversely through said path at transversely spaced points on said member in position to be engaged by the leading edge of a document being delivered in said path and thereby arrest the movement thereof, each said flexible member being formed of a series of small, light, electrically conductive, serially swingably and conductively connected elements.

4. In an apparatus of the character specified, having at least one document collecting bin and means for projecting a document into said bin at high speed in a path traversing said bin at a height above its bottom, means in said bin for arresting the movement of a document along said path comprising a plurality of lengths of chain, freely suspended in laterally spaced relation and each by an end at a point above said path to hang freely through said path transversely thereof and in position for engagement by the leading edge of a document projected in said path to thereby arrest the movement of said document.

5. In an apparatus of the character specified, having at least one document collecting bin, means for projecting a document into said bin at high speed in a path traversing said bin at a height above its bottom, and an electrically conductive and grounded member above a terminal portion of said path, means in said bin for arresting the movement of a document along said path comprising a plurality of lengths of electrically conductive chain, freely

6

suspended, each by an end, from said grounded member to hang freely through said path transversely thereof at laterally spaced points and in position for engagement by spaced portions of the leading edge of a document projected in said path to thereby arrest the movement of said document.

6. In an apparatus of the character specified, having at least one document collecting bin, means for delivering a document into said bin at high speed in a path traversing said bin at a height above its bottom to permit stacking of collected documents in said bin below a terminal portion of said path, and a movable member in said bin and above and normally bearing downwardly against a stack of previously collected documents in said bin and elevated, preparatory to delivery of another document into said bin, to a position above said path, a plurality of light, flexible members laterally spaced transversely of said path and each connected at an end to said movable member whereby, when said movable member is in its elevated position, said flexible members are suspended to hang through said path at laterally spaced points above said stack, each said flexible member being formed of a series of relatively small, light, swingably connected elements.

7. In an apparatus of the character specified, having at least one document collecting bin, means for delivering a document into said bin at high speed in a path traversing said bin at a height above its bottom to permit stacking of collected documents in said bin below a terminal portion of said path, and a movable and electrically conductive and grounded member in said bin above and normally bearing downwardly against a stack of previously collected documents in said bin and elevated, preparatory to delivery of another document into said bin, to a position above said path, a plurality of laterally spaced, light, flexible, electrically conductive members each conductively connected at an end to said movable member whereby, when said movable member is in its elevated position, said flexible members are suspended to hang through said path at laterally spaced points above said stack to intercept a document being delivered in said path, each of said flexible member being formed of a series of relatively small, light, swingably connected, electrically conductive elements.

8. In an apparatus of the character specified, having at least one document collecting bin, means for delivering a document into said bin at high speed in a path traversing said bin at a height above its bottom to permit stacking of collected documents in said bin below a terminal portion of said path, and a movable, electrically conductive and grounded member in said bin above and normally bearing downwardly against a stack of previously collected documents in said bin and elevated, preparatory to delivery of another document into said bin, to a position above said path, a plurality of light, electrically conductive, flexible chains each conductively connected at an end to said movable member at points spaced in the width of said path, whereby, when said movable member is in its elevated position, said chains are suspended to hang through said path at laterally spaced points above said stack to intercept a document being delivered in said path.

9. In an apparatus of the character specified, having at least one bin, a removable, document collecting tray in said bin, means for delivering a document into said bin at high speed in a path above said tray to permit stacking of collected documents in said tray below said path, and a member movably mounted on said tray above and normally bearing downward against a stack of previously collected documents in said tray and elevated, preparatory to delivery of another document into said tray, to a position above said path, a plurality of light, flexible members connected, each at an end, to said movably mounted member at laterally spaced points thereon, whereby, when the latter member is in its elevated posi-

7

tion, said flexible members are suspended to hang through said path in laterally spaced relation above said stack to intercept a document being delivered in said path, each said flexible member being formed of a plurality of relatively small, light, serially swingably connected elements. 5

10. In an apparatus of the character specified, having at least one bin, a removable, document collecting tray in said bin, means for delivering a document into said bin at high speed in a path above said tray to permit stacking of collected documents in said tray below said path, an electrically conductive member movably mounted on said tray above and normally bearing downward against a stack of previously collected documents in said tray, and means to electrically ground said member and to elevate it, preparatory to delivery of another document into said tray, to a position above said path, a 15

8

plurality of light, flexible, electrically conductive chains connected, each at an end, to said movably mounted member in laterally spaced position, whereby when the movable member is in its elevated position, said flexible members are suspended to hang in laterally spaced relation through said path above said stack.

## References Cited in the file of this patent

## UNITED STATES PATENTS

1,573,414	Mahoney -----	Feb. 16, 1926
2,585,076	Bandura et al. -----	Feb. 12, 1952
2,779,450	Mecum -----	Jan. 29, 1957
2,906,527	Blain -----	Sept. 29, 1959