

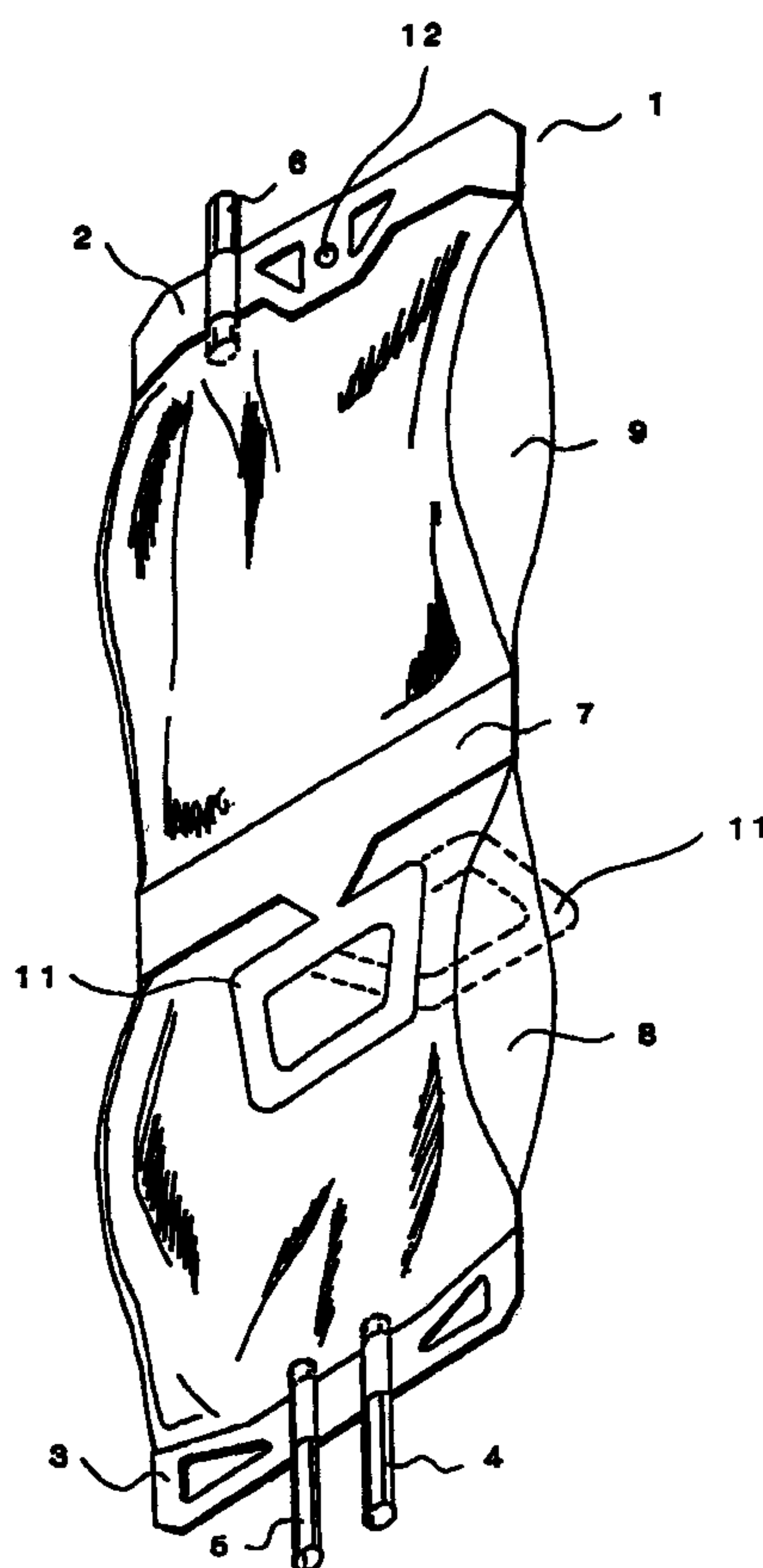

(86) Date de dépôt PCT/PCT Filing Date: 1995/03/28
 (87) Date publication PCT/PCT Publication Date: 1995/10/05
 (45) Date de délivrance/Issue Date: 2010/06/22
 (85) Entrée phase nationale/National Entry: 1995/11/15
 (86) N° demande PCT/PCT Application No.: EP 1995/001152
 (87) N° publication PCT/PCT Publication No.: 1995/026177
 (30) Priorité/Priority: 1994/03/29 (DEP 44 10 876.1)

(51) Cl.Int./Int.Cl. *B32B 7/06* (2006.01),
A61J 1/10 (2006.01), *B29C 65/18* (2006.01),
B29C 65/76 (2006.01), *B32B 27/08* (2006.01),
B65D 30/08 (2006.01), *C08L 23/06* (2006.01),
C08L 23/10 (2006.01), *C08L 53/00* (2006.01)
 (72) Inventeurs/Inventors:
 KREISCHER, THOMAS, DE;
 HEILMANN, KLAUS, DE;
 NICOLA, THOMAS, FR;
 ZIMMERMANN, MICHAEL, DE
 (73) Propriétaire/Owner:
 FRESENIUS AG, DE
 (74) Agent: GOWLING LAFLEUR HENDERSON LLP

(54) Titre : FILM POLYMERE MULTICOUCHE POUR SAC A USAGE MEDICAL A PLUSIEURS COMPARTIMENTS ET
 PROCEDE DE FABRICATION CONNEXE
 (54) Title: MULTILAYER POLYMER FILM FOR A MULTICHAMER MEDICAL BAG AND PROCESS FOR FABRICATION
 THEREOF



(57) Abrégé/Abstract:

The invention concerns a multilayer polymer film and a multichamber bag, whose bag chambers are formed by seams in the outer border zone and by at least one seam in the chamber separation zone, whereby the seams are formed from the polymer materials

(57) **Abrégé(suite)/Abstract(continued):**

facing the chambers. The polymer materials facing the chambers are inseparably sealed together in the outer border zone and sealed together in the chamber separation zone such that the seam is separable with a force which lies in the range from 5 to 20 N. The different strength of the bond from the sealing process is obtained by varying sealing temperatures.

Abstract of the Disclosure

The invention concerns a multilayer polymer film and a multichamber bag, whose bag chambers are formed by seams in the outer border zone and by at least one seam in the chamber separation zone, whereby the seams are formed from the polymer materials facing the chambers.

The polymer materials facing the chambers are inseparably sealed together in the outer border zone and sealed together in the chamber separation zone such that the seam is separable with a force which lies in the range from 5 to 20 N. The different strength of the bond from the sealing process is obtained by varying sealing temperatures.

Multilayer polymer film for a multichamber medical bag and process for fabrication thereof

Description

The invention concerns a multilayer polymer film for a multichamber medical bag for preparation of mixed medical solutions, which has at least two chambers which are separated
5 from each other by a sealed separation zone to be opened and are sealed in the outer border zone, whereby in the seam of the outer border zone at least one tube is provided in at least one chamber.

Multichamber medical bags have been used for years for preparation of mixed solutions. The known multichamber bags have different systems as separation arrangements between the
10 chambers.

One of these systems uses breakable separation parts made of rigid, breakable materials. These have the advantage of largely universal applicability, but have disadvantages to the extent that they only free a limited breaking or mixing opening and undesirable particle formation may occur upon breakage of the separation arrangement.

15 Such a system, which has a predetermined breaking point in the chamber separation zone, which can be broken, for example, by exerting pressure on one chamber, is disclosed in EP 0 378 183, whereby a peel strip is also advantageously included in the seal in the zone of the predetermined breaking point.

A second type of separation arrangement is designed as a squeezing system, which presses the
20 films of the bag, for example, by means of external clamps for sealing and can be opened before use. The advantages of such squeezing systems lie in the possible large mixing opening which can as a rule be produced without any particles. However, such systems are disadvantageous to the extent that they are limited to film materials for the bags which must have high elasticity and temperature resistance in order to effect the desired separation. Often, such systems have leaks.
25 In order to avoid these, it is necessary to precisely coordinate the tolerances of bag thickness and the squeezing system to each other.

In order not to be restricted in squeezing systems to certain types of films as materials for the multichamber bag and to improve the separation action, according to German patent DE 41 07 223, an elastic strip of film which serves as a seal during activation of the squeezing device is disposed in the region of the later mixing opening. Because of the squeezing arrangement and the strip of film, this system has the disadvantage that it is very expensive.

Consequently, the object of the invention is to make available another film for a multichamber medical bag which, upon sealing at a first low temperature, produces a peelable seam and, upon sealing at a second temperature, produces a durable seam.

This object is achieved according to the invention in that the layer of the multilayer film facing the chambers has essentially two components, i.e., a matrix polymer and a phase polymer.

The surprising advantage of the multichamber bag made from the film according to the invention lies in the fact that it is possible, because of the polymer material facing the chambers, to form both inseparable seams in the outer border zone and subsequently separable seams in the chamber separation zone.

A seam in the chamber separation zone should be separable with a force in the range from 5 to 20 N. If the seam is separable with a force of less than 5 N, no reliable separation of the chambers is possible, since the bond can release by itself, for example, as a result of slight shocks during transport which exert pressure on one or a plurality of chambers. At a force of 20 N, the seam can be separated only with great difficulty. There is the danger that instead of the seam, the film will tear and the bag will thus become leaky.

Moreover, the separation force of the seam must be high enough that the bag can withstand a drop from a two-meter height.

The above-described multichamber bag made of the film according to the invention permits a very simple design since neither breakable separation parts nor squeezing arrangements are required. Also, no additional sealing and film materials are needed in the chamber separation zone.

Nevertheless, a reliable separation of the chambers is obtained, whereby the separation is easy to open and, in addition, it leaves the largest possible cross section free.

Preferably, so-called blown or tubular films are used to fabricate the multichamber bag. These may possibly be folded and merely have to be closed, i.e., sealed, on two sides of the outer
5 border, i.e., at the two openings. However, the use of individual sheets of film, which, however, have to be sealed all the way around, is also conceivable.

Generally, a multilayer film is used as a polymer material for multichamber bags. In a preferred embodiment, the multilayer film is a co-extruded multilayer film. It is further preferred that the multilayer film have two to seven layers. But a monofilm of a polymer material is also
10 conceivable for the multichamber bag.

The materials of the multilayer film are selected such that the bag is as transparent and flexible as possible, but, in particular is heat sterilizable and biocompatible. For reasons of biocompatibility and from an environmental standpoint, the use of PVC, which always has a certain proportion of softeners, is ruled out, at least in the inner layer. For the same reasons,
15 materials such as adhesion promoters, which could diffuse into the interior of the bag, should be ruled out.

For specific applications it is moreover necessary that the multilayer film have a gas barrier for oxygen and carbon dioxide as well as a water vapor barrier which prevents diffusion of these gases both into and out of the bag.

20 The layer of the multilayer film facing the chambers, hereinafter referred to as the inner layer, has essentially two components, i.e., a matrix polymer and a phase polymer. The system of matrix and phase polymers is referred to hereinafter as the matrix-phase polymer system.

Polymers with a high excitation or melting temperature range, such as polyethylene homopolymer, polyethylene copolymers, polypropylene homopolymer and polypropylene
25 copolymer may be used as matrix polymers. Polyethylene is used as high density polyethylene (HDPE) or linear low density polyethylene (LLDPE). Of the matrix polymers mentioned, the polypropylene copolymer is preferred. Particularly preferred is a polypropylene random copolymer.

Polymers with a low excitation or melting temperature range, such as styrene ethylene/butylene styrene triblock polymer (SEBS), styrene ethylene/butylene styrene triblock polymer (SEBS) with a styrene ethylene/butylene diblock component (SEB), styrene ethylene/propylene styrene triblock polymer (SEPS), styrene butadiene styrene triblock polymer (SBS), and/or styrene
5 isoprene styrene triblock polymer (SIS), as well as low density polyethylene (LDPE), linear low density polyethylene (LLDPE), terpolymers of ethylene, propylene, and a non conjugated diene (EPDM) and/or ethylene α -olefin copolymer may be used as phase polymers. Preferably, SEBS is used. The proportion of the phase polymer in the inner layer should be in the range from 1 to 40 wt.-%, based on the total matrix-phase polymer system.

10 The phase polymer may also have a processing aid. This aid is used to adjust the viscosity of the polymers. The amount of the aid should be in the range from 1 to 15 wt.-%, based on the amount of the phase polymer. Medical grade white oil may, for example, be used as a processing aid.

The seam of the outer border zone has at least one tube in at least one chamber, whereby this
15 tube is a discharge tube. It is, however, also possible for this discharge tube to be a filling tube.

It is, however, preferred that, in addition to the discharge tube, each chamber to be filled also have a filling tube in the outer border zone. The filling tubes are, however, not absolutely necessary because it is also conceivable in the case of the two chamber bag to first seal the chamber separation zone and then fill each chamber and then seal the respective outer border
20 zone.

It is also possible to isolate the discharge tube from the bag contents by forming an additional separable seam. This results in a three chamber bag which has two chambers to be filled, each with a filling tube, and an empty chamber with a discharge tube. It is possible thus to first mix the solutions of the two filled chambers and then to open the seam which isolates the discharge
25 tube in order to thus release the bag contents. The advantage of this bag consists in that with it, it is possible to do without the disadvantageous break-off valve in the discharge tube.

In order that the chamber separation zone between the two filled chambers is opened first, it is possible to design the seam in the chamber separation zone between the two chambers to be

filled such that the seam can first be opened at a specific point. This may be accomplished in that a part of the seam in the chamber separation zone between the two chambers to be filled is shaped, in a V, for example. In this case, the seam opens first at the point of the V since the force to be exerted is the least there. Consequently, the outer wall is preferably provided
5 precisely in this region with a tear tab, preferably with two tear tabs.

Using these tear tab(s), it is then very simply possible, after complete mixing of the contents of the two filled chambers, to also open the part of the seam of the chamber separation zone which isolates the empty chamber which has the discharge tube.

In an additional separate embodiment, it is, of course, possible to use the seam which separates
10 the discharge tube from the contents of the bag, even with bags which have only one chamber to be filled.

In another embodiment the multichamber bag has a suspension arrangement, which is designed preferably in the form of an opening in the sealed seam opposite the discharge tube. The suspension arrangement is, however, not restricted to this form.

15 The separable seal in the chamber separation zone can be separated by exerting pressure on at least one of the adjacent chambers, with the flat hand, for example. However, it is also possible to provide the outer wall in the chamber separation zone with a tear tab, preferably with two tear tabs.

20 The process for fabrication of the multichamber bag according to the invention is characterized in that the sealing is performed at a higher temperature in the outer border zone than in the chamber separation zone.

For this, it is necessary that the polymer material facing the chambers, preferably the inner layer of the multilayer film, have in its structure chain regions which require high (heat) energy input to excite vibration and a clearly lower [(heat) energy input] in other regions.

25 This structure results in the fact that with sealing at the low temperature only the zones fuse which require low energy to fuse. This is called partial fusing. In contrast, at the higher temperature, both the regions which require low energy input and the regions which require high

energy input fuse. There is a more or less complete fusion of the inner layer. The sealing in the region of the low temperature yields a separable bond and an inseparable bond in the higher temperature areas.

For fabrication of an inner film layer with the above-described properties, in principle the following possibilities exist:

1. Polymer chains of high and low excitation or melting temperature are integrated into one polymer.
2. Both the matrix polymer and the phase polymer have chain areas with high and low excitation or melting temperature.
3. Polymers with high excitation or melting temperature form a matrix in which an additional polymer, which has chain areas with low excitation or melting temperature, is embedded. This so-called matrix-phase polymer system is preferred.

Sealing at the higher temperature is used in the outer border zone since this yields bonds which are no longer separable. This sealing in the outer border zone is preferably performed at a temperature in the range above 128° to 150° C.

Sealing at the low temperature is used in the chamber separation zone since it yields bonds which are separable. This sealing in the chamber separation zone is preferably performed at a temperature of $\leq 128^\circ$ C.

The bottom temperature limit at which the sealing in the chamber separation zone can be performed in order to produce a separable seam varies depending on the inner layer film material used.

The duration of the sealing procedure is preferably in the range from 1 to 8 seconds, and the surface pressure exerted on the zones to be sealed during the sealing procedure is preferably in the range from 0.1 to 3 N. However, for both parameters mentioned, values outside the ranges mentioned are also possible. Both parameters are thus not restricted to the preferred ranges.

The above-described multichamber bag made of the film according to the invention may be used for the preparation of mixed solutions, for example, for dialysis, infusion, or nutrition, whereby the term mixed solutions refers not only to a mixture of solutions, i.e., fluids, but also, for example, in the case of the two-chambered bag, to the mixing of a solution with a solid.

- 5 Additional details, characteristics, and advantages of the invention are presented in the following description of exemplary embodiments with reference to the drawings.

They depict:

FIG. 1 a schematically simplified depiction of a preferred embodiment of a multichamber bag made of the film according to the invention;

- 10 FIG. 2 a schematically simplified depiction of another preferred embodiment of a multichamber bag made of the film according to the invention;

FIG. 3 graphically the results of the tensile strength test of a film according to Example 1;

FIG. 4a the structure of a sealed multilayer film in the outer border zone, which is subsequently inseparable;

- 15 FIG. 4b the structure of a sealed multilayer film in the chamber separation zone, which is subsequently separable.

FIG. 1 depicts a multichamber bag 1 according to a preferred embodiment of the present invention which is designed as a two-chamber bag with two bag chambers 8 and 9.

- 20 The bag 1 is formed from a folded blown film. The two chambers 8 and 9 are formed by seams 2 and 3 (so-called sealing bars) in the outer border zone and by the seam 7 in the chamber separation zone.

In each of the two seams in the outer border zone a tube 5, 6, which can be used for the filling of the bag chamber, is sealed in. In addition, the seam 3 in the outer border zone of the chamber 8 has an additional tube 4, which is designed as a discharge tube.

- 25 For easier handling, the seam 7 has on its outside two tear tabs 11.

Moreover, the seam 2, which is opposite the seam 3, which has the discharge tube, is outfitted with a suspension arrangement 12 in the form of an opening.

FIG. 2 likewise depicts a multichamber bag 1 which is designed as a three-chamber bag, a preferred embodiment of the present invention.

5 The bag 1 is likewise formed from a folded blown film. The chambers 8, 9, and 10 are formed by seams 2 and 3 in the outer border zone and by a seam 7 in the chamber separation zone. The seam 7 in the chamber separation zone is designed such that, for one thing, it separates the two fillable chambers lengthwise of the blown film and, for another, it forms an empty chamber 10.

10 The two chambers 8 and 9 may be filled through filling tubes 5 and 6, which are sealed into the seam 2 of the outer border zone. In the same seam 2 of the outer border zone, the discharge tube 4, which is connected with the empty chamber 10, which is separated from the fillable chambers 8 and 9 by the seam 7, is also sealed in.

Moreover, a suspension arrangement 12 in the form of an opening is provided in the seam 3, which is opposite the seam 2, which has the discharge tube.

15 The present invention is, however, in no way restricted by the embodiments depicted in FIG. 1 and FIG. 2. Many other embodiments are conceivable.

The structure of the film is described in detail in the three following examples with reference to 3-layer films which represent a preferred embodiment. In the examples, the outer layer of the film, which is the side facing away from the chambered bag, is referred to as layer 1. Layer 2 is 20 the middle film and layer 3 is the side of the film facing the chambers.

EXAMPLE 1

3-Layer Film Without Gas Barrier

The film is produced on a 3-layer co-extrusion blown film system. The extruders had 30 D length and are equipped with mixing and shearing parts. The co-extrusion tool is designed as a 25 helical distributor tool.

Film structure:

	<u>Plastic type</u>	<u>Name</u>	<u>Manufacturer</u>	<u>MFI</u>
Layer 1	100% PP homopolymer	Novolen™ 1302H	BASF	1.8 (230/2.16)
Layer 2	70% VLDPE	Teamex™ 1000F	DSM	3.0 (190/2.16)
	30% PP homopolymer	Novolen™ 1302H	BASF	1.8 (230/2.16)
Layer 3	70% PP random copolymer	Novolen™ 3200HX	BASF	1.8 (230/2.16)
	30% SEBS compound	90% Kraton™ G1650	Shell	
		10% Ondina™ G100	Shell	

The SEBS compound was previously compounded and granulated in a separate process step.

Ondina G100 is a paraffin-based medical grade white oil.

- 5 **Example 2:** like Example 1, except that in Layer 3 a commercially available product of the company GW-Kraiburg was used as an SEBS compound.

	<u>Plastic type</u>	<u>Name</u>	<u>Manufacturer</u>	<u>MFI</u>
Layer 3	70% PP-R	Novolen™ 3200HX	BASF	1.8 (230/2.16)
	30% SEBS compound	TFGA AF	GW-Kraiburg	

The films are produced by co-extrusion. Depending on the film structure, starting materials and blends are combined in different layers. Besides the actual invention, the objective here is to obtain “separation seam” properties such as impact resistance, e.g., 2-m drop and gas barrier.

A 3-layer film which is structured according to Examples 1 and 2 was subjected to a sealing test which is described in detail in the following. Two sealing bars with a length of 220 mm and a width of 10 to 15 mm were used as the sealing arrangement. The length of the sealing bars (220 mm) must be at least as long as, preferably somewhat longer than, the seam to be produced (180 mm). Four heating elements with a maximum power of 200 Watt each were applied per sealing bar at equal intervals and 25 mm below the sealing surface. Control was effected via a temperature sensor of the type PT 100 in the center between two heating elements. The film to be sealed was placed between the two sealing bars, one of which is stationary and the other movable. The movable sealing bar was pressed against the stationary sealing bar at a specified pressure by means of a piston (diameter 100 mm).

The sealing time was uniformly 6 seconds. The temperature was varied from 115° C to 131° C, in steps of 2° C. It was possible to vary the pressure from 1 bar to 6 bar, in steps of 1 bar. Because of the geometry of the sealing arrangement (e.g., length and width of the sealing bars as well as the diameter of the piston) and the film (e.g., length and width of the seam), the various pressures yield values for the surface pressure on the zones to be sealed which fall in the range from 0.1 to 3 N.

The starting temperature of the test sequence was set at 115° C, since the film presented no adhesion in the temperature range below that. At a sealing temperature of 131° C and higher, the adhesion of the film surfaces is, on the other hand, so high that in the tensile strength tests the seam was inseparable and the film tore.

The seams of the multichamber bag sealed at different pressures and in the temperature range from 115°C to 131°C were subjected to a tensile strength test according to DIN 53457. The results of this tensile strength test are graphically presented in Figures 3 and 4a-b.

As can be see in Fig. 3, for the films tested, which were produced according to Example 1, the following picture results:

- In the temperature range from 115°C to 122°C, the seam can be separated with a force which is less than 5 N, i.e., the bond of the seal surface is too weak to be able to be used as a seam in multichamber bags according to the invention.

In the temperature range over 128°C to 131°C, the seam can be separated only with a force of more than 20 N, i.e., the seal surfaces are durably bonded to each other.

- In the temperature range from 123°C to 128°C, the seam can be separated with a force in the range from 5 N to 20 N. Optimal peelability, i.e., a bond which can subsequently be separated lies in this temperature range.

The pressure data are the pressures applied during sealing. The properties of the sealed seam are, however, essentially, independent of the pressure applied during sealing, as can readily be seen in Fig. 3.

For the film tested, the following temperature ranges result:

- 10 - A seam which was sealed below 115°C can be separated with a force of less than 5 N, i.e., the bond of the sealing surface is too low to be able to be used as a seam in a multichamber bag according to the invention.
- A seam which was sealed in the temperature range from 115°C to 128°C can be separated with a force in the range from 5 N to 20 N, i.e., such a seam is used according to the invention in the chamber separation zone, since this bond can subsequently be separated.
- 15 - A seam which was sealed in the temperature range above 128°C can be separated only with a force of more than 20 N, i.e., such a seam is used according to the invention in the outer border zone, since these sealing surfaces are durably bonded to each other.

Fig. 4a depicts a 3-layer film 15 structured according to Example I with inner layers 16 and 16' and with middle layers 17 and 17' as well as outer layers 18 and 18' which were sealed at a temperature higher than 128°C. The two inner layers 16 and 16', as can be seen in the graphic, are fused to each other such that an inseparable bond is formed.

Fig. 4b depicts a 3-layer film 15 structured according to Example 1, as was described in Fig. 4a. The difference from Fig. 4a consists only in that the film was sealed in the temperature range from 123°C to 128°C. In this case, the two inner layers 16 and 16', as can be seen in the graphic, are fused to each other such that a subsequently separable bond is formed.

THE EMBODIMENTS OF THE INVENTION IN WHICH AN EXCLUSIVE PROPERTY OF PRIVILEGE IS CLAIMED ARE DEFINED AS FOLLOWS:

1. A method for the welding of a polymer multi-layer film containing two or more layers, which at a first welding temperature enter into a peelable joint and at a second, higher welding temperature a firm joint, and one of the two outer layers has a matrix phase polymer system, whereby the matrix polymer is a polyethylene homopolymer, a polypropylene homopolymer or a polypropylene copolymer and the phase polymer is a styrene-ethylene/butylene-styrene triblock polymer (SEBS) with a styrene-ethylene/butylene diblock fraction (SEB), a styrene-ethylene/propylene-styrene triblock polymer (SEPS), a styrene-butadiene-styrene triblock polymer (SBS) and/or a styrene-isoprene-styrene triblock polymer (SIS), wherein the fraction of the phase polymer is in the region of 1-40 wt. %, related to the matrix phase polymer system, and wherein a peelable joint separable with a force in the region of 5-20 N is produced by means of heat contact with a welder terminal at a temperature in the region of 123°C to 128°C.
2. The method according to claim 1, wherein the multi-layer film is a co-extruded multi-layer film.
3. The method according to claim 1 or 2, wherein the multi-layer film has two to seven layers.
4. The method according to any one of claims 1-3, wherein the phase polymer can additionally have a processing aid.
5. The method according to any one of claims 1-4, wherein the multi-layer film has a gas barrier layer for oxygen and carbon dioxide as well as a water-vapour barrier layer.
6. A medical multi-chamber bag made of a polymer material for the production of medical mixed solutions, which has at least two chambers which are separated from one another by a welded separation area to be opened and are welded in the outer-edge area, whereby at least one tube connector is provided in at least one chamber in the weld seam of the outer-edge area, whereby the multi-chamber bag is produced from a polymer multi-layer film, which contains two or more layers,

which at a first welding temperature enter into a peelable joint and at a second, higher welding temperature a firm joint, wherein the layer facing the chambers has a matrix phase polymer system, whereby the matrix polymer is a polyethylene homopolymer, a polypropylene homopolymer or a polypropylene copolymer and the phase polymer is a styrene-ethylene/butylene-styrene triblock polymer (SEBS) with a styrene-ethylene/butylene diblock fraction (SEB), a styrene-ethylene/propylene-styrene triblock polymer (SEPS), a styrene-butadiene-styrene triblock polymer (SBS) and/or a styrene-isoprene-styrene triblock polymer (SIS), whereby the layer having the matrix phase polymer system is not in contact with a layer of an RF-responsive material.

7. The multi-chamber bag according to claim 6, wherein the weld seam in the separation area is separable with a force in the region of 5-20 N and the weld seam is not separable in the outer-edge area.
8. The multi-chamber bag according to claim 6 or 7, wherein the multi-chamber bag is heat-sterilisable.
9. The multi-chamber bag according to any one of claims 6-8, wherein, in addition to the outlet tube connector, each chamber to be filled also has at least one filling tube connector, which is arranged in the weld seam of the outer-edge area.
10. The multi-chamber bag according to any one of claims 6-9, wherein the outer wall in the chamber separation area is provided with at least one tear tab.
11. The multi-chamber bag according to claim 10, wherein the outer wall in the chamber separation area is provided with two tear tabs.
12. A use of the medical multi-chamber bag according to any one of claims 6-11 for the production of mixed solutions for dialysis, infusion or nutrition.

Fig. 1

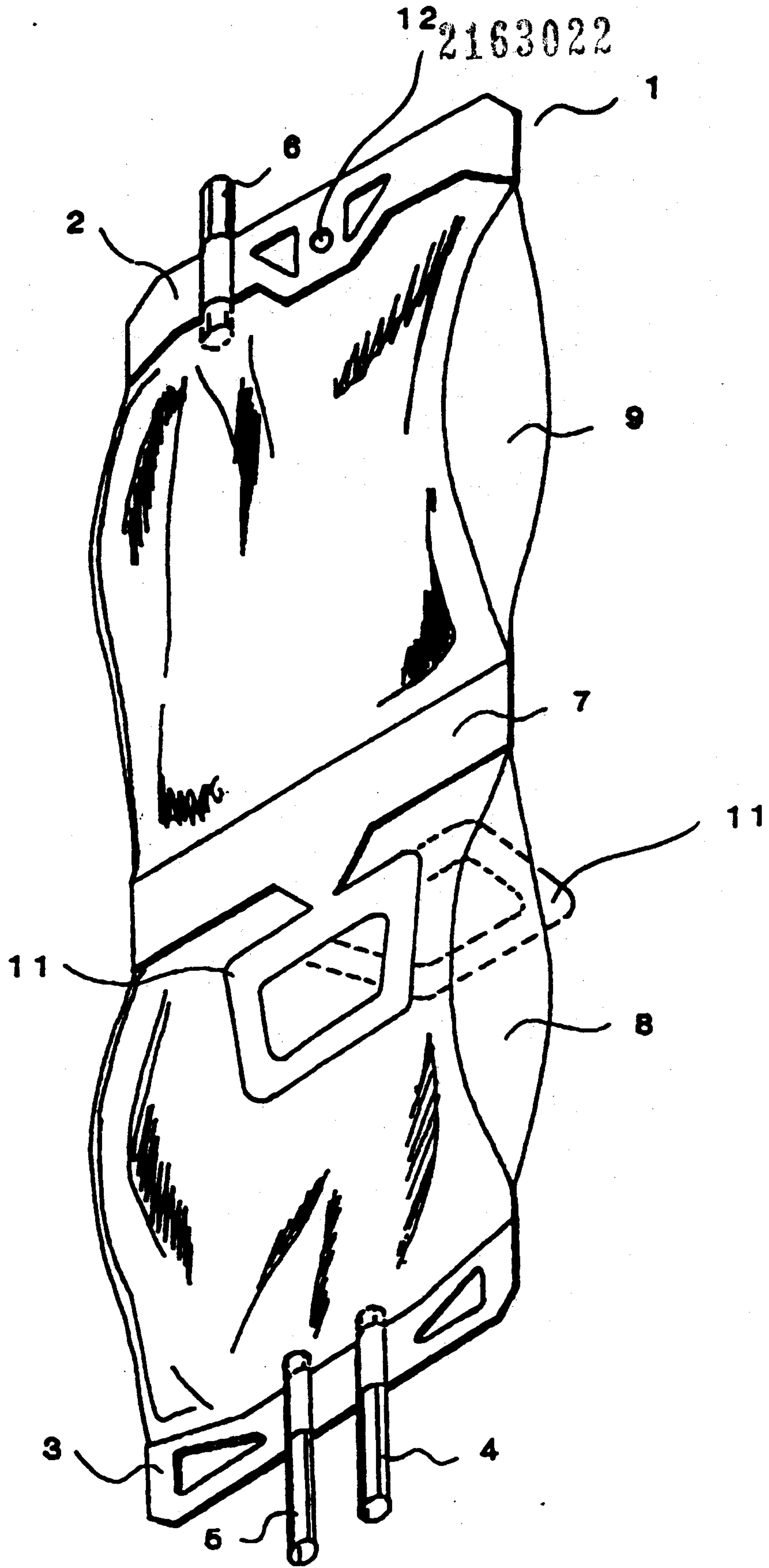

Fig. 2

2163022

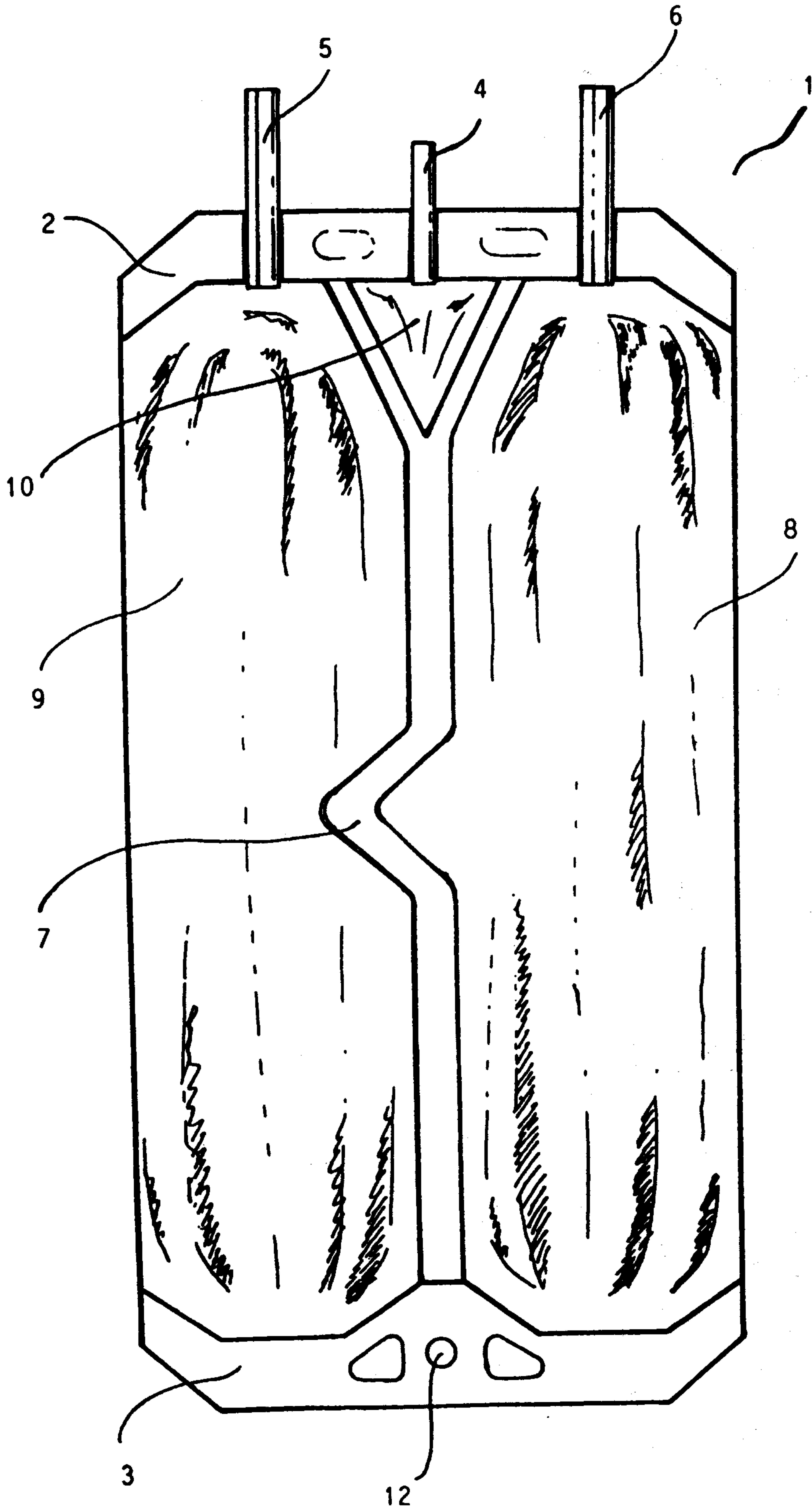

Fig. 3

Tensile strength test of multichamber bag seam (Film Example No. 1)

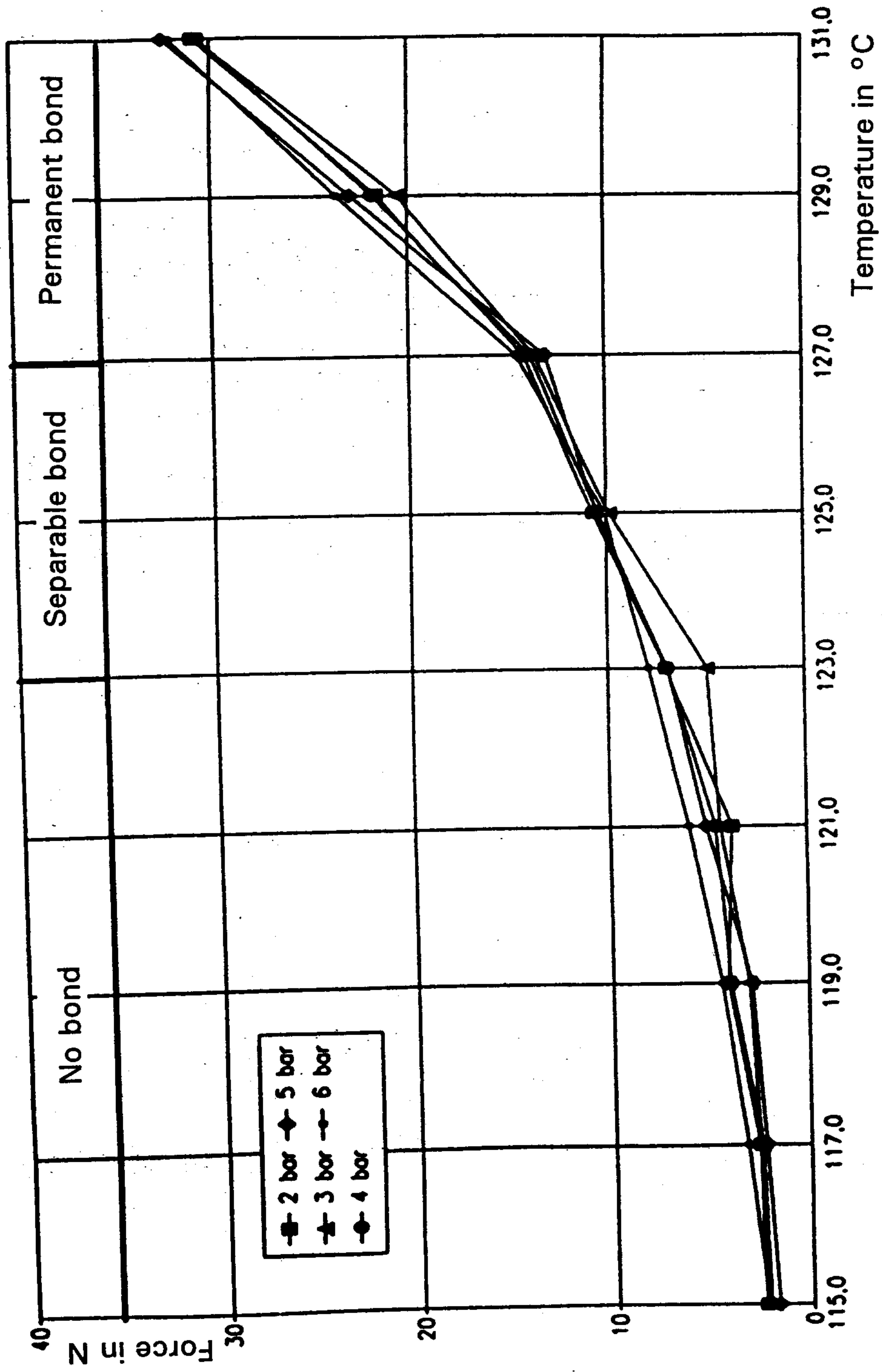

FIG. 4a

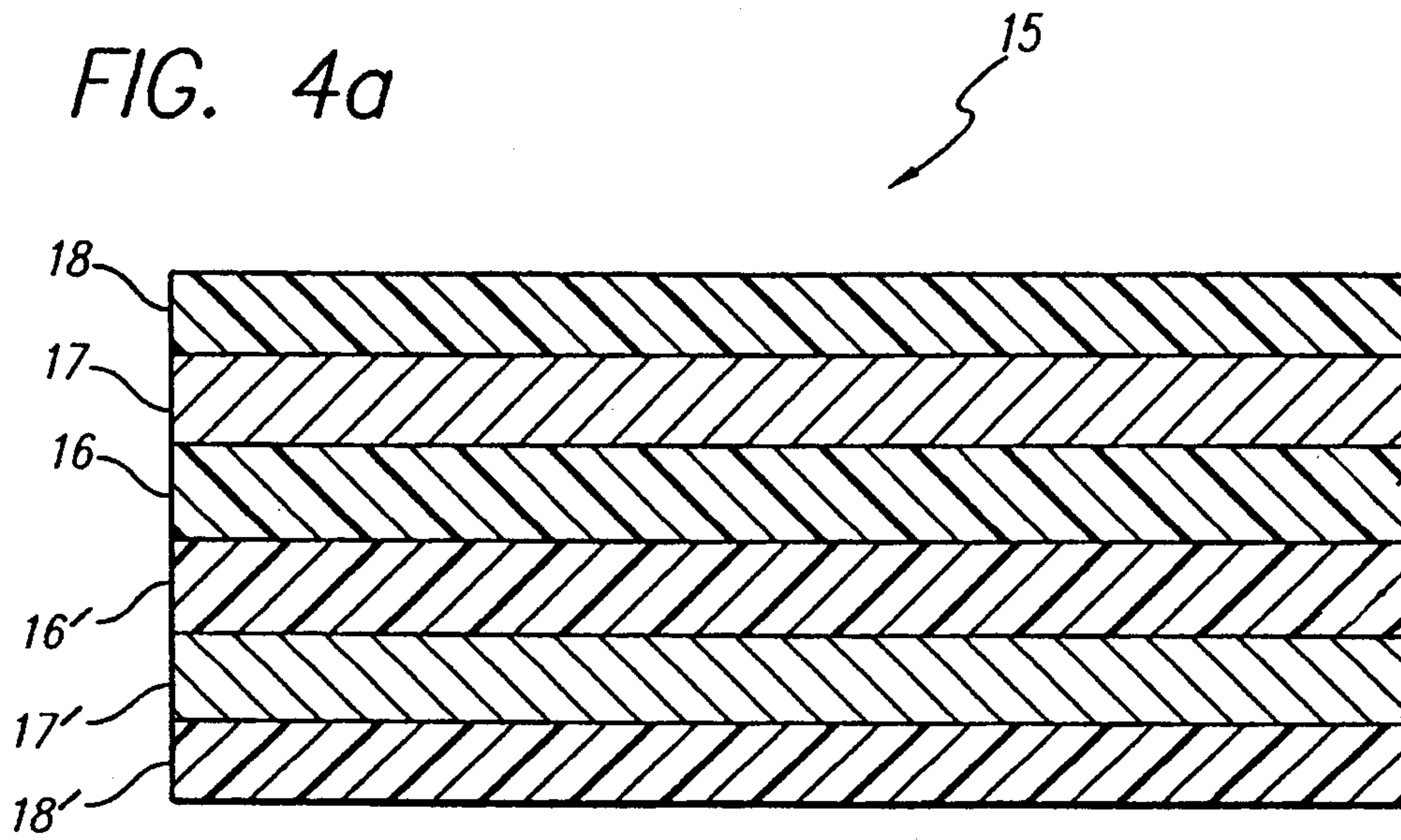

FIG. 4b

