

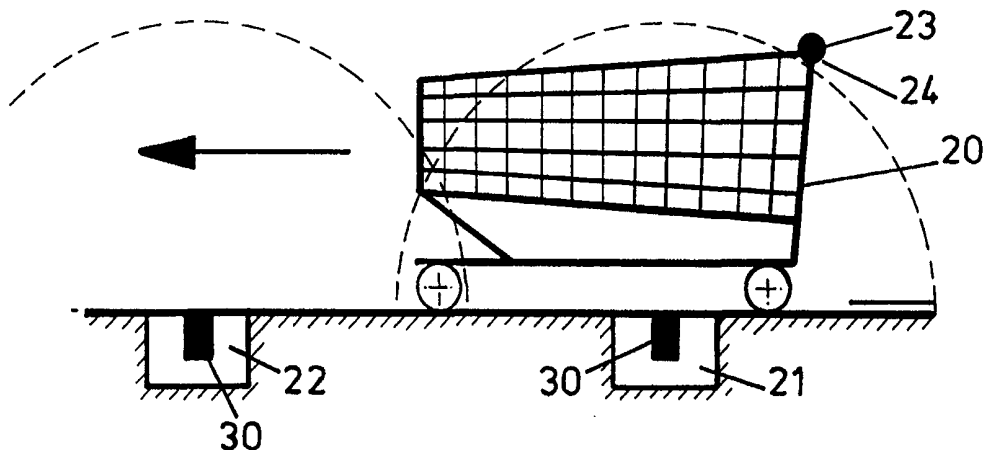

INTERNATIONAL APPLICATION PUBLISHED UNDER THE PATENT COOPERATION TREATY (PCT)

<p>(51) International Patent Classification <sup>6</sup> : <b>G07G 1/00, G07C 11/00, G07G 3/00</b></p>	<p><b>A1</b></p>	<p>(11) International Publication Number: <b>WO 99/59112</b> (43) International Publication Date: 18 November 1999 (18.11.99)</p>
<p>(21) International Application Number: PCT/GB99/01232 (22) International Filing Date: 10 May 1999 (10.05.99) (30) Priority Data: 9809914.6 9 May 1998 (09.05.98) GB 9828675.0 29 December 1998 (29.12.98) GB (71) Applicant (for all designated States except US): TAGGA LTD. [GB/GB]; 7M Lakeland Business Park, Lamplugh Road, Cockermouth, Cumbria CA13 0QT (GB). (72) Inventors; and (75) Inventors/Applicants (for US only): WALKER, Nigel, John [GB/GB]; 5 Devonshire Arcade, Penrith, Cumbria CA11 7SX (GB). WHELAN, Brian [GB/GB]; Braemar, Annan Road, Gretna, Dumfriesshire DG16 5DQ (GB). (74) Agent: EVERY, David, Aidan; Marks &amp; Clerk, Sussex House, 83-85 Mosley Street, Manchester M2 3LG (GB).</p>		<p>(81) Designated States: AL, AM, AT, AU, AZ, BA, BB, BG, BR, BY, CA, CH, CN, CU, CZ, DE, DK, EE, ES, FI, GB, GD, GE, GH, GM, HR, HU, ID, IL, IN, IS, JP, KE, KG, KP, KR, KZ, LC, LK, LR, LS, LT, LU, LV, MD, MG, MK, MN, MW, MX, NO, NZ, PL, PT, RO, RU, SD, SE, SG, SI, SK, SL, TJ, TM, TR, TT, UA, UG, US, UZ, VN, YU, ZA, ZW, ARIPO patent (GH, GM, KE, LS, MW, SD, SL, SZ, UG, ZW), Eurasian patent (AM, AZ, BY, KG, KZ, MD, RU, TJ, TM), European patent (AT, BE, CH, CY, DE, DK, ES, FI, FR, GB, GR, IE, IT, LU, MC, NL, PT, SE), OAPI patent (BF, BJ, CF, CG, CI, CM, GA, GN, GW, ML, MR, NE, SN, TD, TG).  <b>Published</b> <i>With international search report.</i> <i>With amended claims.</i></p>

(54) Title: GOODS AND CLIENTS MONITORING IN A RETAIL STORE



(57) Abstract

The retail store of the present invention is designed to detect the potential theft of goods from a store by customers and to enable capture of data reflecting the shopping behaviour of customers to provision of such data enables improved store management. The produce is conveyed around the store by the customer in a produce-carrier. The produce-carrier or customer carries an identification device attached to each carrier and bearing a readable identification code. The customer transport selected produce in the produce-carrier to a payment area at which the selected produce is purchased. Readers for reading the identification tags are distributed about the store including at the payment area. Outputs from the reader are connected to means for generating data representative of the position of produce-carrier or customer in time and space in the store. The system helps reduce theft, enables personalised promotion or marketing, reduces queuing at checkouts and other areas and enables efficient recirculation of produce-carriers, and enables staff deployment in response to varying levels of activity in a store.

**FOR THE PURPOSES OF INFORMATION ONLY**

Codes used to identify States party to the PCT on the front pages of pamphlets publishing international applications under the PCT.

AL	Albania	ES	Spain	LS	Lesotho	SI	Slovenia
AM	Armenia	FI	Finland	LT	Lithuania	SK	Slovakia
AT	Austria	FR	France	LU	Luxembourg	SN	Senegal
AU	Australia	GA	Gabon	LV	Latvia	SZ	Swaziland
AZ	Azerbaijan	GB	United Kingdom	MC	Monaco	TD	Chad
BA	Bosnia and Herzegovina	GE	Georgia	MD	Republic of Moldova	TG	Togo
BB	Barbados	GH	Ghana	MG	Madagascar	TJ	Tajikistan
BE	Belgium	GN	Guinea	MK	The former Yugoslav Republic of Macedonia	TM	Turkmenistan
BF	Burkina Faso	GR	Greece			TR	Turkey
BG	Bulgaria	HU	Hungary	ML	Mali	TT	Trinidad and Tobago
BJ	Benin	IE	Ireland	MN	Mongolia	UA	Ukraine
BR	Brazil	IL	Israel	MR	Mauritania	UG	Uganda
BY	Belarus	IS	Iceland	MW	Malawi	US	United States of America
CA	Canada	IT	Italy	MX	Mexico	UZ	Uzbekistan
CF	Central African Republic	JP	Japan	NE	Niger	VN	Viet Nam
CG	Congo	KE	Kenya	NL	Netherlands	YU	Yugoslavia
CH	Switzerland	KG	Kyrgyzstan	NO	Norway	ZW	Zimbabwe
CI	Côte d'Ivoire	KP	Democratic People's Republic of Korea	NZ	New Zealand		
CM	Cameroon			PL	Poland		
CN	China	KR	Republic of Korea	PT	Portugal		
CU	Cuba	KZ	Kazakstan	RO	Romania		
CZ	Czech Republic	LC	Saint Lucia	RU	Russian Federation		
DE	Germany	LI	Liechtenstein	SD	Sudan		
DK	Denmark	LK	Sri Lanka	SE	Sweden		
EE	Estonia	LR	Liberia	SG	Singapore		

## GOODS AND CLIENTS MONITORING IN A RETAIL STORE

The present invention relates to a retail store such as, for example, a supermarket.

Theft of goods from supermarkets is a constant problem. In spite of security personnel and surveillance cameras located within a supermarket store it is still possible for a customer to wheel a trolley into a store, load it with goods and exit the store without paying. The presence of extra security personnel in and around the store does help reduce the rate of theft of this nature but it also has a tendency to intimidate customers and to deter them from frequenting the store. In addition, it is often not possible for the store management to identify with sufficient confidence a customer leaving the store with goods that have not been purchased. This is particularly problematic if the customer, having paid for one load of goods, re-enters the store, loads more goods into the trolley and then leaves the store without paying. It requires the security personnel to stop a customer and make a detailed inspection of the goods in the trolley and the itemised payment receipt in order to determine whether a theft has occurred. Security personnel have to be cautious in approaching suspected thieves for fear of adverse publicity for the store in the case of an unwarranted inspection of the trolley contents.

Supermarket stores are generally arranged in a fashion that enables theft to occur. In particular, a typical store has an entrance/exit lobby that is occupied with customers awaiting transport and a plurality of payment aisles, not all of which are manned at any one time. A thief can load a trolley with goods and leave the store through the entrance/exit lobby without having passed through a payment aisle or, alternatively can pass through a payment aisle which is not manned.

The movement of customers around a store and the timing of their arrival at check-out tills is difficult to predict. The nature of shopping is peculiar to the individual and without the possibility of identifying customers' shopping patterns aspects of store management, other than security, are also made difficult.

It is an object of the present invention to obviate or mitigate the aforesaid disadvantages and provide a retail store in which improved store management is possible.

According to a first aspect of the present invention there is provided a retail store in which customers transport produce-carriers into the store, select produce, place the selected produce into the produce-carriers and transport the selected produce in the produce-carriers to a payment area at which the selected produce is purchased, wherein the produce-carriers incorporate identification tags, and readers for reading the identification tags are distributed about the store including at the payment area, outputs from the readers being connected to means for generating data representative of the position of the produce-carriers in time and space in the store.

The customer may carry an identification tag in addition to the produce-carrier having a tag so that produce-carrier data can be married to a customer identification data.

According to a second aspect of the present invention, there is provided a retail store in which customers transport produce-carriers into the store, select produce, place the selected produce into the produce-carriers and transport the selected produce in the carriers to a payment area at which the selected produce is purchased, wherein the customers carry identification tags, and readers for reading the identification tags are distributed about the store including at the payment area, outputs from the readers being connected to means for generating data representative of the position of the individual customers in time and space in the store.

The store preferably further comprises an entry/exit zone, a goods zone and a payment zone, containing said payment area, least one reader is disposed at the entry and exit of each zone, a security alarm, and the means for generating data is a controller coupled to each reader for storing the identification code of a detected produce-carrier and the location of the reader, coupled to the payment area for storing payment information when the customer has paid for the produce and coupled to the alarm, so that upon detection by a reader of a produce-carrier leaving the payment zone or entering the entry/exit zone, the controller determines from the identification

code of that carrier whether payment information has been stored for that produce-carrier and if not activates the alarm.

The alarm may be audio and/or visual and is intended to alert the potential theft of goods to security personnel of the store. In this regard the alarm may have several levels of priority each indicative of the likelihood of potential theft.

The identification tag may comprise a radio coil and electronics circuit that stores the identification code, the identification code being transmitted by the coil to the reader when the carrier passes within a range of the detector.

In a preferred embodiment the goods area is sub-divided into zones, each zone being assigned a priority.

Preferably the produce-carrier bears a readable number plate to enable security personnel to identify a carrier easily.

At least some of the detectors are preferably arranged into spaced pairs so that the direction of travel of a produce-carrier relative to the readers can be ascertained.

Each produce-carrier or customer may conveniently have more than one identification tag

The controller may be programmed with information relating to physical features of each carrier.

The retail store may advantageously further comprise means for providing advance warning of customer congestion in the payment area.

In addition or alternatively the store may also have means for activating an advertisement aimed at a particular customer.

A specific embodiment of the present invention will now be described, by way of example only, with reference to the accompanying drawings in which:

Figure 1 is a diagrammatic representation in plan view of a supermarket store of the present invention;

Figure 2 is a schematic block diagram of a controller of the present invention.

Figure 3 is a side view of trolley fitted with an identification device of the present invention in the vicinity of a detector:

Figure 4 is a diagrammatic plan view of the detector array and trolley of figure 3; and

Figure 5 is a diagrammatic plan view of a payment zone and desk of the present invention;

Referring now to the drawings, figure 1 shows a floor-plan of the exemplary store that is typical to many existing supermarket stores. The store can be divided into several notional areas which are indicated in figure 1. The area outside the store, represented by reference numeral 1 in figure 1, may include a car-park and a trolley park. Customers enter the store through an entrance door 3 that leads to a lobby area 3. This area may typically accommodate a waiting area for customers who have finished their shopping but are waiting for a fellow customer or for transport, a customer information desk, an information noticeboard and a separate sales area for certain goods such as tobacco, lottery tickets or the like. The customer picks up a trolley, basket or other suitable carrier from a designated area outside 1 or in the lobby 3. Immediately beyond the lobby 3 is a goods area 4 which is the major part of the store where the goods are displayed on shelves, in refrigerators or other display equipment for customers to take the required goods from the display and place them in the trolley or basket. The area designated by reference numeral 5 is for premium goods that are most likely to be stolen, such as alcoholic beverages or other expensive goods.

In order to leave the store a customer has to pass through one of a plurality of parallel payment aisles 6 in a payment area 7. Typically each aisle is occupied by a payment till 8 that is manned by a cashier who operates the till 9 to calculate the bill and accepts payment from the customer. After leaving the payment area 7 the customer leaves the store through the lobby 3 and an exit door 9. It will be understood that, in practice, the entrance and exit doors 2, 9 are often one and the same.

The store of figure 1 is shown fitted with an information gathering system to form the present invention. As will be discussed later each trolley or basket is fitted with an identification tag that may be read by detectors that are disposed around the store. The detectors are arranged into arrays that are mounted on or under the floor,

overhead or into walls of the store. The arrays serve to delineate the store areas described above. In the example shown in figure 1 there is a detector array 10 at the entrance and exit doors 2, 9, a pair of spaced arrays 11a, 11b separating the goods area 4 from the lobby 3, a pair of spaced arrays 12a, 12b in each payment aisle 6 serving to separate the payment area 7 from the goods area 4, and a detector array 13 separating the payment area 7 from the lobby 3.

As described below, the detectors 10, 11a, 11b, 12a, 12b, 13 are designed to detect the presence of a passing trolley or basket and to read information relating to the trolley from the identification tag. This enables the movement of any particular trolley or basket to be tracked around the store.

The detectors 10, 11a, 11b, 12a, 12b, 13 and the payment tills 8 are each coupled to a central controlling computer 14 (as shown schematically in figure 2) having appropriate software and communication interfaces as part of a local area network. Information is read from the trolley identification tag as it passes over each detector 10, 11a, 11b, 12a, 12b, 13 and information relating to payment from each payment till 8 is transmitted to the computer 14 which then stores the data in a memory 15. A security alarm 16 which may be audible or visual is controlled by the computer 14.

Figures 3 and 4 show a typical supermarket trolley 20 moving from right to left over the store floor in which there are disposed spaced first and second detectors 21, 22. The conventional trolley 20 is fitted with an identification tag 23 which, in the example embodiment shown, is securely moulded in a handle 24 of the trolley 20 so as to be hidden from view and difficult to remove. In other embodiments, not shown, the tag 23 may be moulded into part of the mesh of the trolley or welded to the wire frame. The identification tag (not shown in detail in the figures) comprises a radio pick-up coil and a small, integrated electronics circuit programmed with a unique identification code and is of robust design being able to withstand all weather conditions when parked outside the store and collisions with, for example, other trolleys.

Each detector array 10, 11a, 11b, 12a, 12b, 13 comprises a plurality of laterally spaced conventional transceivers 30 that transmit at a specific radio frequency. As the trolley 20 passes within the detection range (represented by the arcuate dotted lines in figures 2 and 3) of a transceiver 30 the transmission is picked up by the radio coil of the identification tag 23. The tag 23 stores sufficient energy from the transmission to transmit its identification code back to the transceiver 30 without the need of its own power source. The information captured by the transceiver 30 is passed to the controlling computer 14.

The transceivers 30 within each detection array 10, 11a, 11b, 12a, 12b, 13 are spaced laterally such that the detection ranges of adjacent transceivers 30 overlap (see figure 4) and the full width of an aisle is covered. This prevents a trolley identification tag 23 passing between transceivers 30 without being detected. The arrangement of a pair of spaced detector arrays in close proximity (as described above) enables the direction of travel of the trolley 20 to be determined. As the trolley 20 passes from right to left in figures 3 and 4 the first detector 21 of the pair reads the identification tag 23 when it comes into range. As the trolley 20 advances the tag 23 moves out of range of the first detector 21 and into the range of the second detector 22 which then reads the identification tag 23. The information is fed to the controlling computer 14 which is able to ascertain the direction of travel of the trolley 20 by knowing which detector 21, 22 read the identification tag 23 first.

When a customer has finished loading his/her trolley in the goods area 4 he/she then should enter the payment area 7 by selecting one of the payment tills 8 and entering the appropriate payment aisle 6, an example of which is shown in figure 5. The presence of the trolley 20 in payment area 7 is detected as described above by the detector array 12a. Here the goods are unloaded on to a conveyor belt 40 by which they are conveyed towards a cashier (not shown) at the payment till 8 who enters the prices into the till 8 in a known manner so as to calculate the total bill for the goods. When the cashier receives payment from the customer a signal is sent from the payment till 8 to the control computer 14 to indicate that payment has been received. This information is linked to the trolley identification code detected by the detector



array 12a when the trolley 20 entered the payment aisle 6. The signal is sent automatically by, for example, a switch that is operated when the till drawer is opened. Once payment has been registered the trolley 20 is able to leave the store without triggering the security alarm 16.

When a trolley 20 enters the goods area 4 from the lobby 3 it is detected and identified by one of the transceivers 30 in the detector array 11a. The information transmitted to the controlling computer 14 alerts the system that the trolley 20 potentially contains goods for which payment must be registered. If the trolley 20 enters the premium goods area 5 the computer 14 assigns the information relating to the trolley a priority flag. If the trolley 20 enters the payment aisle 6 and payment is registered then no action is taken by the computer 14. However, if the trolley 20 is detected leaving a payment aisle 6 or passing back into the lobby 3 without payment having been registered (the customer, for example, having passed through an unmanned payment aisle or having re-entered the lobby 3 from the goods area 4 without passing through the payment area 7) the computer 14 ascertains whether the trolley 20 has entered the goods area 4 and, if so, activates the alarm 16 to alert security staff. The alarm 16 may be, for example, a visual warning on a security surveillance screen or an audible signal designed to alert security staff of a potential theft. The payment receipt may be marked with an identified number of the trolley so as to assist the security personnel in assessing whether a theft has occurred.

By alerting security staff before the trolley 20 leaves the store adequate warning is provided to intercept a potential thief.

The system helps prevent thefts which occur when a customer who, having entered the goods area 4 once and paid for the goods in the payment area 7, then proceeds to re-enter the goods area 4, load more goods into the trolley 20 and leave without paying (either by passing through an unmanned aisle or passing from the goods area to the exit through the lobby). In this scenario the re-entry of the customer into the goods area 4 will be detected so that if the customer leaves without further payment having been registered the alarm 16 will be activated as described above.

To counteract attempts to remove or shield the identification tag 23 a plurality of tags may be fitted to each trolley 20. In addition metal detectors may be deployed at appropriate positions in the store to detect the presence of an otherwise unidentifiable trolley and alert security staff of its existence.

Each trolley 20 may be fitted with some form of visual identification such as, for example, a number plate (not shown) so that it may be easily identified by security staff or by an appropriate automated reader in the event of an alert. The number plate may be designed so that it is also readable by a detector so that if the tag 23 is missing the trolley 20 could still be identified. The system would also be able to detect if the number plate did not match the identification code of the tag 23. The computer memory 15 could be programmed with a description of each trolley so that the security staff could request such details when any particular trolley is detected. If the stored details do not match the actual trolley (viewed on camera by the security staff) appropriate action may be taken.

The system may also be used as part of a marketing or promotional tool in which the progress of customers and/or their trolleys is tracked around the store so that shopping patterns of customers can be deduced. If the customers are issued with storecards bearing identification tags, similar to those provided in the trolleys, marketing information can be broadcast in a selective manner so that it is aimed at a particular customer and be personalised having regard to the information stored by a storecard database. If both the customers and the trolleys have an identification tag the captured information can be used to identify any particular customer that is using any particular trolley.

The system is also able to provide an indication to staff including, in particular porters as to the relative distribution of trolleys outside of the store. This means that porters can be alerted to a situation where the number of trolleys in the trolley park immediately outside the entrance of the store is running low.

It is envisaged that the identification tag can be present in the storecard only. Alternatively, identification data relating to the customer may be transferred to the tag in the trolley by, for example, swiping the storecard over a card reader on the trolley.

This would enable store management to use data captured from the storecard and/or the trolley to influence the shopping behaviour of a particular customer by, for example, tailoring promotions in reaction to the position of the customer in the store and having regard to data on the storecard that reflects the shopping behaviour of the customer. Even if customers are not carrying identification tags, non-personalised promotional or marketing information can still be broadcast in reaction to the position of a trolley (and therefore customer). Moreover, by monitoring the progress of trolleys around the store, the system would be able to identify in advance when there is likely to be congestion at the payment tills and indicate that a certain number of additional cashiers is required to prevent significant customer queues at the payment desks. Furthermore, there may be provided a customer messaging system (which may be audio and/or visual) that assists customers in identifying a payment till that is free or has a relatively small queue. This may also be used to prevent queue jumping by reserving an identified customer a place at a particular free checkout.

The position of identified customers at speciality counters may also be detected by the use, if necessary, of additional readers. This would enable a customer to reserve his/her position in the queue for service whilst they continue to shop in other parts of the store. A visual and/or audio personalised message is broadcast to warn customers that staff are ready or nearly ready to serve him or her.

In preventing theft, not only is financial loss limited, but since unaccounted loss of stock is reduced, more accurate stock information is generated thereby enabling improved control over stock re-ordering.

It has been established that a significant amount of theft is committed by members of staff of a retail store. In an optional embodiment of the present invention the staff may also carry identification tags. These may be integral with their own staff identification or access cards or may, for example, form part of their uniform. Readers in the staff areas such as the warehouse and cold stores would enable the system to track the movements of members of staff in the same way as customers thereby reducing the possibility of theft. The term "customer" in the appended claims is intended to cover a member of staff.

With the captured data being stored with a time and date reference, the system enables traffic patterns and flow rates to be stored on a historical basis and for current patterns or predicted future patterns to be provided including the number of trolleys present in any given area of the store at any given time and the rate of trolleys entering the store. This information allows more efficient store management such as, for example, the reduction of waiting times at payment check-outs or other counters and the improved re-circulation of trolleys by porters.

In addition in-store marketing can be improved by both targeting promotions to particular customers and monitoring reactions to any marketing techniques.

It is to be understood that reference to "a retail store" also includes the store car park.

It will be appreciated that numerous modifications to the above described design may be made without departing from the scope of the invention as defined in the appended claims. The identification tag and detector may be of any appropriate design which enables an trolley identification code to be read by the detector such as a bar code plate reader. For example, the identification tag and detector may be in the form of a bar code plate and a bar code reader respectively. Furthermore, the controller may be a single computer processor or several linked processors. The system not only applies to trolleys but any form of alternative goods carrier such as, for example, a basket.

CLAIMS

1. A retail store in which customers transport produce-carriers into the store, select produce, place the selected produce into the produce-carriers and transport the selected produce in the produce-carriers to a payment area at which the selected produce is purchased, wherein the produce-carriers incorporate identification tags, and readers for reading the identification tags are distributed about the store including at the payment area, outputs from the readers being connected to means for generating data representative of the position of the produce-carriers in time and space in the store.
2. A retail store in which customers transport produce-carriers into the store, select produce, place the selected produce into the produce-carriers and transport the selected produce in the produce-carriers to a payment area at which the selected produce is purchased, wherein the customers carry identification tags, and readers for reading the identification tags are distributed about the store including at the payment area, outputs from the readers being connected to means for generating data representative of the position of the individual customers in time and space in the store.
3. A retail store according to claim 1, wherein the customer also carries an identification tag and there is provided means for identifying the customer.
4. A retail store according to claim 2 or 3, wherein the produce-carrier incorporates a reader for identifying the customer.
5. A retail store according to claim 4, wherein the reader identifies the customer by reading data from the identification tag.

6. A retail store according to any preceding claim wherein the store has an entrance and exit area in which at least one reader is disposed.
7. A retail store according to any preceding claim, wherein the store has an entry/exit zone, a goods zone and a payment zone, containing said payment area, at least one reader is disposed at the entry and exit of each zone, a security alarm, and the means for generating data is a controller coupled to each reader for storing the identification code of a detected produce-carrier and the location of the reader, coupled to the payment area for storing payment information when the customer has paid for the produce and coupled to the alarm, so that upon detection by a reader of a produce-carrier leaving the payment zone or entering the entry/exit zone, the controller determines from the identification code of that carrier whether payment information has been stored for that produce-carrier and if not activates the alarm.
8. A retail store according to claim 7, wherein the alarm is audio and/or visual.
9. A retail store according to claim 8, wherein the alarm has a plurality of priority levels.
10. A retail store according to any preceding claim, wherein the identification tag comprises a radio coil and electronics circuit that stores the identification code, the identification code being transmitted by the coil to the detector when the carrier passes within a range of the reader.
11. A retail store according to claim 7, wherein the goods area is sub-divided into zones, each zone having assigned a priority.
12. A retail store according to any preceding claim, wherein the produce-carrier bears a readable number plate.

13. A retail store according to any preceding claim, wherein at least some of the readers are arranged into spaced pairs so that the direction of travel of a produce-carrier or customer relative to the readers can be ascertained.
14. A retail store according to any preceding claim, wherein each produce-carrier or customer has more than one identification tag.
15. A retail store according to any preceding claim, wherein the means for generating data is programmed with information relating to physical features of each produce-carrier.
16. A retail store according to any preceding claim, further comprising means for providing advance warning of customer congestion in the payment area.
17. A retail store according to any preceding claim, further comprising means for activating an advertisement aimed at a particular customer.
18. A retail store according to claim 2, further comprising staff zones that are occupied by staff only, each of the zones having at least one reader.
19. A retail store substantially as hereinbefore described with reference to the accompanying drawings.

**AMENDED CLAIMS**

[received by the International Bureau on 14 October 1999 (14.10.99);  
original claims 1-19 replaced by new claims 1-13 (3 pages)]

1. A retail store in which customers transport produce-carriers into the store, select produce, place the selected produce into the produce-carriers and transport the selected produce in the produce-carriers to a payment area at which the selected produce is purchased, wherein the produce-carriers incorporate identification tags, and readers for reading the identification tags are distributed about the store including at the payment area, outputs from the readers being connected to means for generating data representative of the position of the produce-carriers in time and space in the store characterised in that the customer also carries an identification tag and the produce-carrier incorporates a reader for identifying the customer.
2. A retail store in which customers transport produce-carriers into the store, select produce, place the selected produce into the produce-carriers and transport the selected produce in the produce-carriers to a payment area at which the selected produce is purchased, wherein the customers carry identification tags, and readers for reading the identification tags are distributed about the store including at the payment area, outputs from the readers being connected to means for generating data representative of the position of the individual customers in time and space in the store, characterised in that the produce-carrier incorporates a reader for identifying the customer.
3. A retail store according to claim 1 or 2, wherein the reader identifies the customer by reading data from the identification tag.
4. A retail store according to claim 1, 2 or 3 wherein the store has a produce area that is sub-divided into zones, each zone having assigned a priority.



5. A retail store according to any preceding claim wherein the store has an entrance and exit area in which at least one reader is disposed.
6. A retail store according to any preceding claim, wherein the store has an entry/exit zone, a goods zone and a payment zone, containing said payment area, at least one reader is disposed at the entry and exit of each zone, a security alarm, and the means for generating data is a controller coupled to each reader for storing the identification code of a detected produce-carrier and the location of the reader, coupled to the payment area for storing payment information when the customer has paid for the produce and coupled to the alarm, so that upon detection by a reader of a produce-carrier leaving the payment zone or entering the entry/exit zone, the controller determines from the identification code of that carrier whether payment information has been stored for that produce-carrier and if not activates the alarm.
7. A retail store according to claim 6, wherein the alarm has a plurality of priority levels.
8. A retail store according to any preceding claim, wherein the means for generating data is programmed with information relating to physical features of each produce-carrier.
9. A retail store according to any preceding claim, wherein the produce-carrier bears a readable number plate.
10. A retail store according to any preceding claim, wherein each produce-carrier or customer has more than one identification tag.

11. A retail store according to any preceding claim, wherein at least some of the readers are arranged into spaced pairs so that the direction of travel of a produce-carrier or customer relative to the readers can be ascertained.
12. A retail store according to any preceding claim, further comprising means for reserving a particular customer position in a queue of customers in the payment area.
13. A retail store according to any preceding claim, further comprising means for activating an advertisement aimed at a particular customer.

# INTERNATIONAL SEARCH REPORT

International Application No

PCT/GB 99/01232

**A. CLASSIFICATION OF SUBJECT MATTER**

IPC 6 G07G1/00 G07C11/00 G07G3/00

According to International Patent Classification (IPC) or to both national classification and IPC

**B. FIELDS SEARCHED**

Minimum documentation searched (classification system followed by classification symbols)

IPC 6 G07G A47F G07F G07C G06F

Documentation searched other than minimum documentation to the extent that such documents are included in the fields searched

Electronic data base consulted during the international search (name of data base and, where practical, search terms used)

**C. DOCUMENTS CONSIDERED TO BE RELEVANT**

Category °	Citation of document, with indication, where appropriate, of the relevant passages	Relevant to claim No.
X	DE 44 31 204 A (DAIMLER BENZ AEROSPACE AG) 7 March 1996 (1996-03-07)  the whole document ---	1, 3, 6, 7, 11, 13, 16, 17
X	DE 43 19 584 A (WANZL ENTWICKLUNG GMBH) 15 December 1994 (1994-12-15)  the whole document ---	1-3, 6, 7, 10, 11, 13, 16, 17
X	DE 195 29 456 C (SIEGEL GEB GMBH CO KG) 24 October 1996 (1996-10-24) the whole document ---	1, 6-8, 11, 13, 17
X	EP 0 374 877 A (SONNENDORFER HORST ;WIETH FRANZ (DE)) 27 June 1990 (1990-06-27) the whole document ---	1, 6-8, 13, 17
	-/--	

Further documents are listed in the continuation of box C.

Patent family members are listed in annex.

° Special categories of cited documents :

- "A" document defining the general state of the art which is not considered to be of particular relevance
- "E" earlier document but published on or after the international filing date
- "L" document which may throw doubts on priority claim(s) or which is cited to establish the publication date of another citation or other special reason (as specified)
- "O" document referring to an oral disclosure, use, exhibition or other means
- "P" document published prior to the international filing date but later than the priority date claimed

- "T" later document published after the international filing date or priority date and not in conflict with the application but cited to understand the principle or theory underlying the invention
- "X" document of particular relevance; the claimed invention cannot be considered novel or cannot be considered to involve an inventive step when the document is taken alone
- "Y" document of particular relevance; the claimed invention cannot be considered to involve an inventive step when the document is combined with one or more other such documents, such combination being obvious to a person skilled in the art.
- "&" document member of the same patent family

Date of the actual completion of the international search

19 August 1999

Date of mailing of the international search report

27/08/1999

Name and mailing address of the ISA

European Patent Office, P.B. 5818 Patentlaan 2  
NL - 2280 HV Rijswijk  
Tel. (+31-70) 340-2040, Tx. 31 651 epo nl,  
Fax: (+31-70) 340-3016

Authorized officer

Guivol, 0

INTERNATIONAL SEARCH REPORT

International Application No

PCT/GB 99/01232

C.(Continuation) DOCUMENTS CONSIDERED TO BE RELEVANT

Category	Citation of document, with indication, where appropriate, of the relevant passages	Relevant to claim No.
A	US 5 287 266 A (MALEC JOHN ET AL) 15 February 1994 (1994-02-15) ----	1,2,6
A	EP 0 827 123 A (PALOMAR TECHN CORP) 4 March 1998 (1998-03-04) the whole document ----	7-12
A	FR 2 607 921 A (EVRIKA STE CIVILE) 10 June 1988 (1988-06-10)  the whole document ----	1,6-8, 10,11, 13,17
A	WO 96 04161 A (ERNST LEON KEITH ;TEC CARTE INTERNATIONAL PTY LI (AU)) 15 February 1996 (1996-02-15) abstract; claims 1,17-24; figures -----	1,6-13

# INTERNATIONAL SEARCH REPORT

Information on patent family members

International Application No

PCT/GB 99/01232

Patent document cited in search report	Publication date	Patent family member(s)	Publication date
DE 4431204 A	07-03-1996	NONE	
DE 4319584 A	15-12-1994	DE 9313108 U	14-07-1994
DE 19529456 C	24-10-1996	NONE	
EP 0374877 A	27-06-1990	DE 3843093 A	28-06-1990
US 5287266 A	15-02-1994	US 4973952 A	27-11-1990
		US 5295064 A	15-03-1994
		AT 136378 T	15-04-1996
		AU 636809 B	06-05-1993
		AU 1098492 A	14-05-1992
		AU 635169 B	11-03-1993
		AU 1098592 A	07-05-1992
		AU 633457 B	28-01-1993
		AU 1098692 A	07-05-1992
		AU 616917 B	14-11-1991
		AU 2521588 A	17-04-1989
		CA 1300235 A	05-05-1992
		CA 1322577 A	28-09-1993
		CA 1330367 A	21-06-1994
		DE 3855178 D	09-05-1996
		DE 3855178 T	28-11-1996
		DK 246089 A	19-05-1989
		EP 0335931 A	11-10-1989
		FI 892436 A	19-05-1989
		JP 2501237 T	26-04-1990
		JP 2743340 B	22-04-1998
		WO 8902628 A	23-03-1994
EP 0827123 A	04-03-1998	US 5874896 A	23-02-1999
		AU 3525497 A	05-03-1998
		CA 2213716 A	26-02-1998
		JP 10124764 A	15-05-1998
FR 2607921 A	10-06-1988	NONE	
WO 9604161 A	15-02-1996	AU 694251 B	16-07-1998
		AU 3072595 A	04-03-1996
		CA 2195754 A	15-02-1996
		EP 0770014 A	02-05-1997
		NZ 290091 A	24-09-1998
		ZA 9506315 A	14-03-1996