

(No Model.)

2 Sheets—Sheet 1.

W. ROEMER.  
BAG LOCK.

No. 524,811.

Patented Aug. 21, 1894.

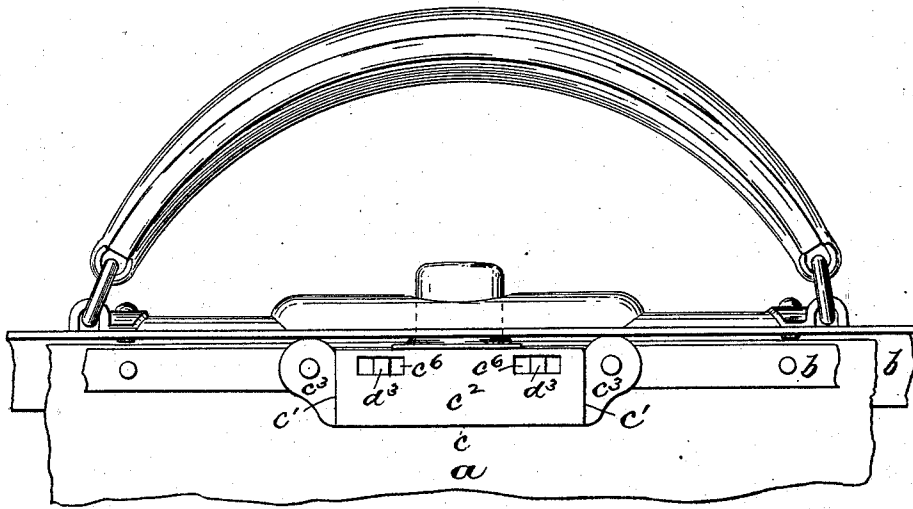

Fig. 1.

Witnesses

Inventor

Robert Lollberger  
Chas. H. Skinner

William Roemer,

By Draxler & Co. Atty's.

(No Model.)

2 Sheets—Sheet 2.

# W. ROEMER. BAG LOCK.

No. 524,811.

Patented Aug. 21, 1894.

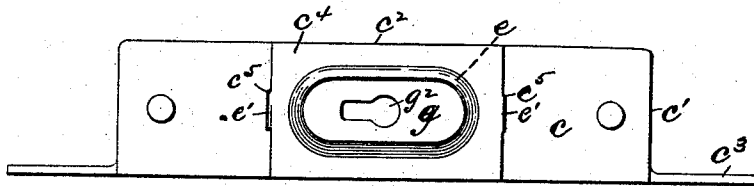
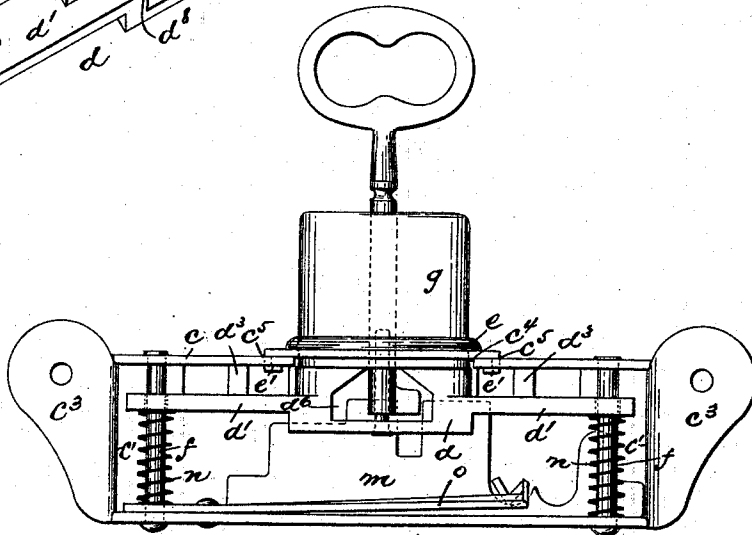
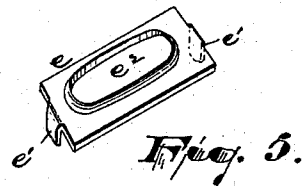
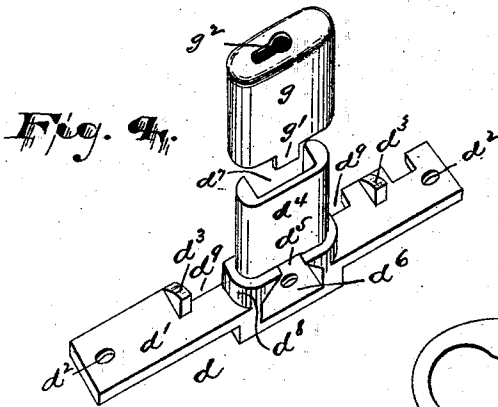

Witnesses:

Inventor:

Robert Sollberger.  
Chas. H. Skinner

William Roemer,

By Drake & Co., Attys.

# UNITED STATES PATENT OFFICE.

WILLIAM ROEMER, OF NEWARK, NEW JERSEY, ASSIGNOR TO ELIZABETH ROEMER, OF SAME PLACE.

## BAG-LOCK.

SPECIFICATION forming part of Letters Patent No. 524,811, dated August 21, 1894.

Application filed October 6, 1893. Serial No. 487,335. (No model.)

*To all whom it may concern:*

Be it known that I, WILLIAM ROEMER, a citizen of the United States, residing at Newark, in the county of Essex and State of New Jersey, have invented certain new and useful Improvements in Locks for Bag or Satchel Frames; and I do hereby declare the following to be a full, clear, and exact description of the invention, such as will enable others skilled in the art to which it appertains to make and use the same, reference being had to the accompanying drawings, and to letters of reference marked thereon, which form a part of this specification.

The object of this invention is to reduce the cost of construction of the locking mechanisms and it consists in the arrangements and combinations of parts substantially as will be hereinafter set forth and finally embraced in the clauses of the claim.

Referring to the accompanying drawings in which like letters indicate corresponding parts in each of the figures, Figure 1 is an elevation of a portion of the bag or satchel having the locking devices and handle. Fig. 2 is an enlarged elevation of the lock removed from the frame to show the arrangement of the working parts. Fig. 3 is a plan of said case; Fig. 4 a perspective of a certain casting and a key-hole cap therefor, and Fig. 5 is a perspective of a base piece for covering the lower end or base of the key-hole cap and form a guide for said cap to slide in.

In said drawings, *a* indicates the bag or satchel and *b*, the frame thereof, which, in the preferred construction, is angular and forms, on the inner side of the satchel, a horizontal corner in which the lock is secured, as will be understood upon reference to Fig. 1.

The lock case is struck up from sheet metal, the four sides *c*, *c*, *c'*, *c'*, being bent at right angles to the face plate *c<sup>2</sup>*, the ends *c'*, *c'*, being again bent to form ears *c<sup>3</sup>*, *c<sup>3</sup>*, which lie back from the face plate, *c<sup>2</sup>*, but parallel therewith. The upper side is longitudinally slotted or open at the center, the opening extending out to or through the edge, as shown at *c<sup>4</sup>*, to allow the insertion of the casting, *d*, and its co-operating parts. Adjacent to said opening, *c<sup>4</sup>*, at the opposite ends thereof, the said up-

per plate is perforated as at *c<sup>5</sup>*, *c<sup>5</sup>*, to receive the lips or lugs *e'* of the base piece *e*, as will be hereinafter described.

The casting, *d*, is of irregular form and embraces the horizontal bar, *d'*, which lies longitudinally within the case and moves vertically therein on suitable ways or tracks *f*, *f*, the said horizontal bar being preferably perforated near its opposite ends, as at *d<sup>2</sup>*, *d<sup>2</sup>*, Fig. 4, to receive said ways which preferably are simple rods or pins secured in the upper and lower sides of the case as shown in Fig. 2. On the upper face of said bar at points between the center and said perforations are catch projections, *d<sup>3</sup>*, which coincide with perforations *c<sup>6</sup>*, Fig. 1, through the face plate, *c<sup>2</sup>*, and serve to receive and hold the locking tongue of the co-operating jaw (not shown) of the frame *b*, in any ordinary manner.

At the center of said horizontal bar, the casting, *d*, is provided with a projection, *d<sup>4</sup>*, Fig. 4, adapted to receive a key hole or finger cap *g*. Said projection is made to snugly fit the said cap so that when the latter is placed thereon there will be no looseness or opportunity for lateral movement and at its lower part is provided with a recess or opening, *d<sup>5</sup>*, adapted to receive a lug, *g'*, which, when bent into said opening, holds said cap, *g*, from vertical disengagement from the projection *d<sup>4</sup>*. The opening or recess, *d<sup>5</sup>*, may be, and preferably is a part of the horizontal opening, *d<sup>6</sup>*, which admits the pivotal movement of the bit of the key. To allow the casting, *d*, to be drawn from the sand easily and to dispense with the use of cores in molding, and, at the same time, to secure an open and free passage for the key, I have cast one side of the vertical projection, *d<sup>4</sup>*, open, as at *d<sup>7</sup>*, the opening being covered and concealed by the cap *g*. At the base of the projection, *d<sup>4</sup>*, is a raised shoulder, *d<sup>8</sup>*, which serves to limit the downward movement of the cap, *g*, thereon.

The vertical play of the casting within the lock case is controlled by the key bolt, *m*, which moves horizontally, when operated by the key in the usual manner, to a position to prevent vertical movement of the casting or to lock the same, or to a position admitting vertical movement as will be understood.

The casting is recessed at one side, as at  $d^9$  to receive the bolt when pressed downward to its lower position.

5 The casting is held normally up in a locking or catching position in the case by suitable springs,  $n$ , and the key bolt,  $m$ , is held in either locking or unlocked position by a spring,  $o$ , which springs  $n$  and  $o$  are not new.

10 The cap,  $g$ , where it engages the shoulder,  $d^8$ , is covered by a base piece,  $e$ , which conceals the joint between the cap and shoulder. This said piece,  $e$ , is held to the top plate or side of the case by lugs,  $e'$ , as above described and at the center is slotted as at,  $e^2$ , to provide a way for said cap, the latter fitting nicely in said slot so as to have a vertical movement therein without lateral play. The upper, exposed end of the cap is provided with an ordinary key-hole  $g^2$ .

20 Having thus described the invention and indicated the operations of the parts, what I claim as new is—

1. The combination with the lock case, and its bolt,  $m$ , and springs  $n$ , of a casting,  $d$ , 25 movable vertically in said case and having catch projections,  $d^3$ , and a central projection  $d^4$ , having the vertical opening at one side, at  $d^7$ , to admit the insertion of the key and a cap,  $g$ , covering said projection and having 30 a key hole,  $g^2$ , substantially as set forth.

2. In combination with the lock case and

its bolt and springs, a vertically movable casting having the projection,  $d^4$ , extending through the case the said projection being provided with a key passage  $d^7$  and a cap  $g$  35 having key hole  $g^2$  and a base piece  $e$ , having lugs  $e'$  secured to the top of the case and covering the lower edge of the cap, substantially as set forth.

3. The combination, in a satchel or bag 40 lock, the repressible casting  $d$ , having a vertical projection,  $d^4$ , and a key-passage, opening at one side, and a cap having lips or lugs  $g'$  adapted to be bent into a recess of said projection substantially as set forth. 45

4. In a lock for satchels or bags, the combination with the repressible casting  $d$  having the projection  $d^4$  extending upward through the case, the said case, the bolt  $m$  and springs 50  $f$ , of a cap  $g$ , covering said projection and fastened thereto and a base piece  $e$  fastened to said case and provided with a slot in which said cap moves vertically, substantially as set forth.

In testimony that I claim the foregoing I 55 have hereunto set my hand this 6th day of September, 1893.

WILLIAM ROEMER.

Witnesses:

CHARLES H. PELL,  
OLIVER DRAKE.