

(No Model.)

B. N. BOTTS.
ACOUSTIC TELEPHONE.

No. 286,680.

Patented Oct. 16, 1883.

Fig. 1.

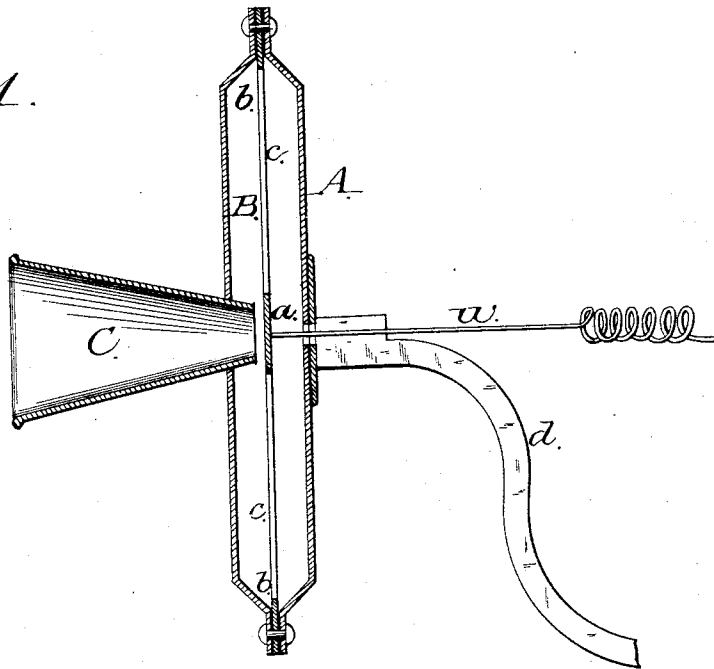
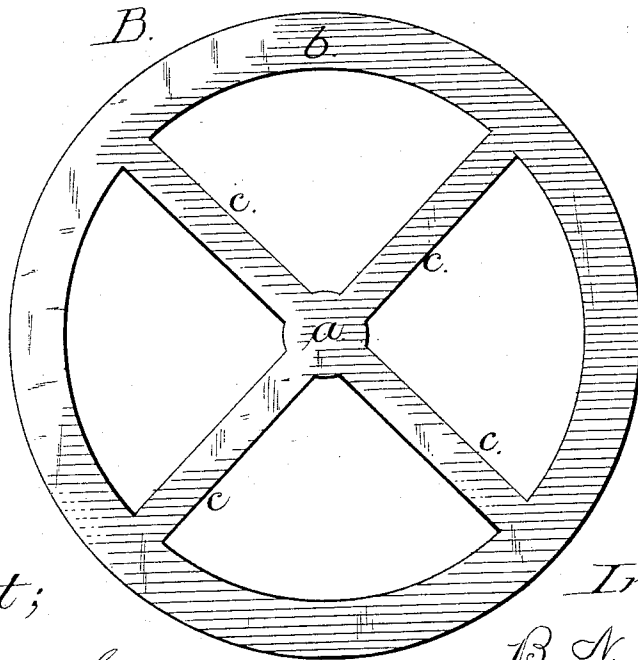

Fig. 2.



Attest;

D. Walter Fowler,
A. L. Collamer,

Inventor;

B. N. Botts,
per Atty.
A. H. Evans & Co.

UNITED STATES PATENT OFFICE.

BARNET N. BOTTS, OF PASO ROBLES, CALIFORNIA.

ACOUSTIC TELEPHONE.

SPECIFICATION forming part of Letters Patent No. 286,680, dated October 16, 1883.

Application filed March 31, 1883. (No model.)

To all whom it may concern:

Be it known that I, BARNET N. BOTTS, of Paso Robles, San Luis Obispo county, State of California, have invented an Improved Acoustic Telephone; and I do hereby declare the following to be a full, clear, and exact description thereof.

My invention relates to certain new and useful improvements in acoustic telephones.

These improvements consist in the construction of the diaphragm of either a transmitter or a receiver and a funnel-shaped mouth-piece in connection with said diaphragm, whereby it is rendered operative.

The object of my invention is to furnish a simple and effective telephone, which object I attain in the following manner, reference being made to the accompanying drawings, in which—

Figure 1 is a vertical section of my device. Fig. 2 is a view of the diaphragm.

A represents a shallow casing, between the sides of which is clamped, in the usual manner, a diaphragm, B. This diaphragm (which is plainly seen in Fig. 2) is constructed of thin metal, so cut away as to leave nothing but a small central hub or surface, *a*, and a rim, *b*, the two being connected by radial arms *c*.

Into the face of the casing A is let the mouth-piece C, of funnel shape, as shown. The inner opening of the mouth-piece has about an equal diameter as the central surface, *a*, of the diaphragm, and is in immediate relation therewith. With the back of the center of the diaphragm is connected the wire *w*, which passes out of the casing, and is connected as will hereinafter be explained. A solid plate, which is generally used, cannot be affected as readily nor to the same degree as this light open diaphragm. The inertia of the air must be overcome, and its resistance materially impedes vibration. Therefore by having a small surface, as the center *a*, it does not meet with as

much resistance, and if the same power be applied its vibrations will be stronger than if it were a solid plate. In order to concentrate the sound-waves produced by the voice directly upon this small vibratory surface, the mouth-piece is made of shape shown and described. By the use of this highly-sensitive diaphragm, none of the energy of the voice is lost, and therefore it can be transmitted to a greater distance and with more volume than if it were first resisted by a less delicate transmitter. This diaphragm is equally serviceable as a receiver, and its utility is not confined alone to acoustic telephones, (for which, however, it is specially adapted;) but it may be used in electric telephones as well.

Having thus described my invention, what I claim as new, and desire to secure by Letters Patent, is—

1. In a telephone apparatus, a diaphragm having a small central surface to receive the vibrations, an outer rim, by which it is clamped, and light open-work intervening to secure the center to rim, substantially as and for the purpose herein described.

2. In a telephone apparatus, the diaphragm B, consisting of a small center, *a*, the rim *b*, and the radial arms *c*, substantially as and for the purpose herein described.

3. In a telephone apparatus, the diaphragm B, having the small center *a*, the rim *b*, and the radial arms *c*, in combination with the funnel-shaped mouth-piece C, arranged to concentrate the sound-waves on the small center *a*, substantially as and for the purpose herein described.

In witness whereof I have hereunto set my hand.

BARNET N. BOTTS.

Witnesses:

P. H. DUNN,
VIRGIL SMITH.