

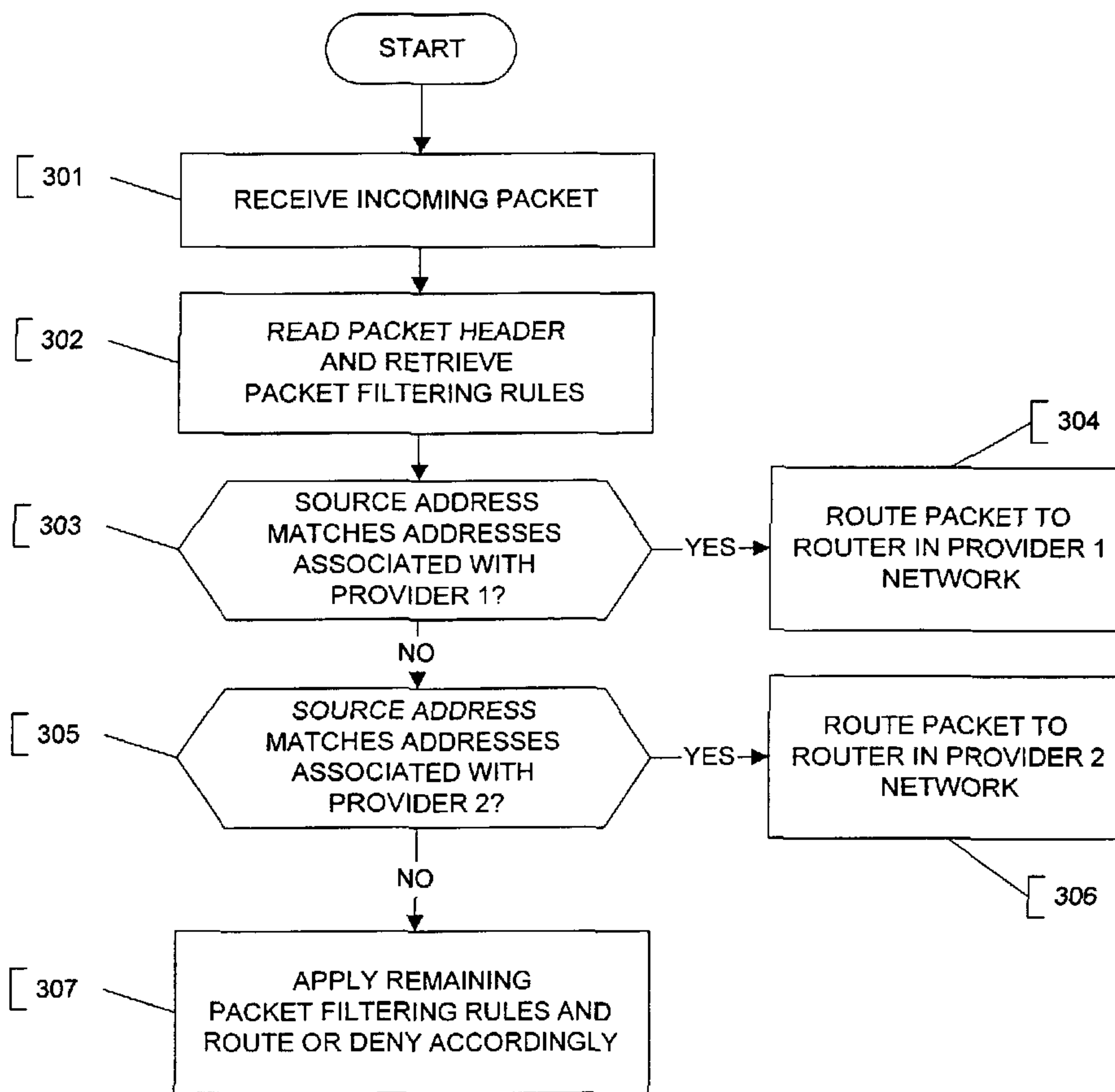

(86) Date de dépôt PCT/PCT Filing Date: 2001/03/20
 (87) Date publication PCT/PCT Publication Date: 2001/09/27
 (85) Entrée phase nationale/National Entry: 2002/09/19
 (86) N° demande PCT/PCT Application No.: US 2001/008846
 (87) N° publication PCT/PCT Publication No.: 2001/071982
 (30) Priorités/Priorities: 2000/03/20 (60/190,636) US;
 2000/03/20 (60/190,633) US

(51) Cl.Int.⁷/Int.Cl.⁷ H04L 12/28
 (71) Demandeur/Applicant:
 AT&T CORP., US
 (72) Inventeurs/Inventors:
 KALMANEK, CHARLES R., US;
 RAMAKRISHNAN, KANDANGODE K., US;
 NGUYEN, HAN Q., US;
 MURPHY, LAWRENCE R., US;
 GARRETT, JOHN W., US
 (74) Agent: KIRBY EADES GALE BAKER

(54) Titre : SELECTION DE SERVICES DANS UN RESEAU A ACCES PARTAGE AVEC DEMARCHE DE ROUTAGE
 (54) Title: SERVICE SELECTION IN A SHARED ACCESS NETWORK USING POLICY ROUTING



(57) **Abrégé/Abstract:**

It is an object of the invention to enable multiple services or service providers to share the facilities of an access network infrastructure providing physical connectivity to subscribers. A network access device advantageously may be used in

(57) Abrégé(suite)/Abstract(continued):

communication network services with a service or service provider that is separate from the operator of the access network infrastructure.

(12) INTERNATIONAL APPLICATION PUBLISHED UNDER THE PATENT COOPERATION TREATY (PCT)

(19) World Intellectual Property Organization
International Bureau



(43) International Publication Date
27 September 2001 (27.09.2001)

PCT

(10) International Publication Number
WO 01/71982 A1

- (51) International Patent Classification⁷: **H04L 12/28** NJ 07736 (US). **MURPHY, Lawrence, R.**; 180 Park Avenue, Florham Park, NJ 07932 (US). **GARRETT, John, W.**; 411 Mathers Lane, Neshanic Station, NJ 08853 (US).
- (21) International Application Number: PCT/US01/08846
- (22) International Filing Date: 20 March 2001 (20.03.2001) (74) Agents: **DWORETSKY, Samuel, H.** et al.; AT & T Corp., P.O. Box 4110, Middletown, NJ 07748-4110 (US).
- (25) Filing Language: English (81) Designated States (*national*): AU, BR, CA, CN, IL, KR, MX.
- (26) Publication Language: English (84) Designated States (*regional*): European patent (AT, BE, CH, CY, DE, DK, ES, FI, FR, GB, GR, IE, IT, LU, MC, NL, PT, SE, TR).
- (30) Priority Data:
60/190,633 20 March 2000 (20.03.2000) US
60/190,636 20 March 2000 (20.03.2000) US
- (71) Applicant: **AT & T CORP.** [US/US]; 32 Avenue of the Americas, New York, NY 10013-2412 (US).
- (72) Inventors: **KALMANEK, Charles, R.**; 86 Great Hills Road, Short Hills, NJ 07078 (US). **RAMAKRISHNAN, Kandangode, K.**; 9 Highland Circle, Berkeley Heights, NJ 07922 (US). **NGUYEN, Han, Q.**; 2 Tharp Lane, Marlboro,

Published:

- with international search report
- before the expiration of the time limit for amending the claims and to be republished in the event of receipt of amendments

For two-letter codes and other abbreviations, refer to the "Guidance Notes on Codes and Abbreviations" appearing at the beginning of each regular issue of the PCT Gazette.

(54) Title: SERVICE SELECTION IN A SHARED ACCESS NETWORK USING POLICY ROUTING

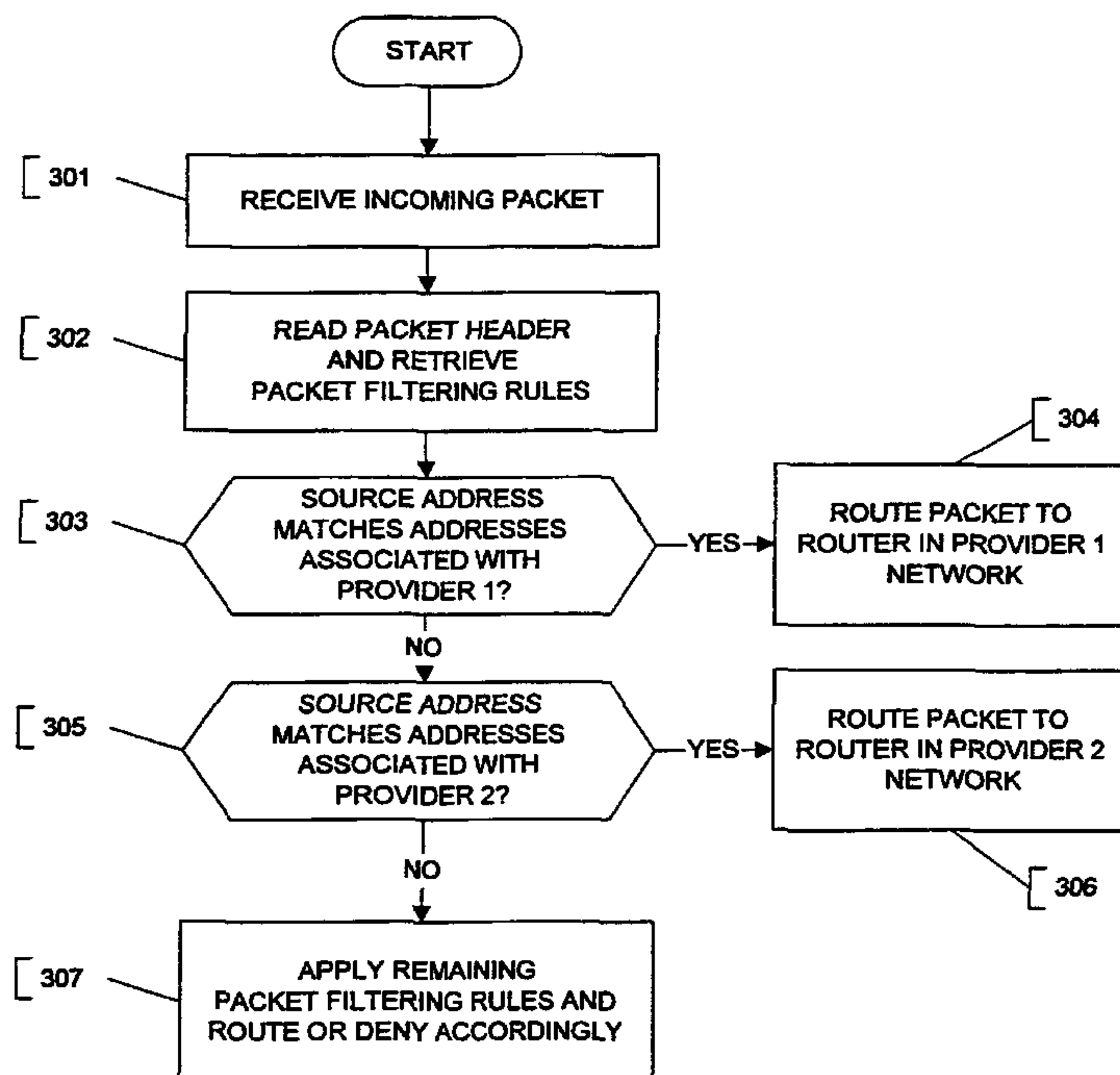

(57) Abstract: It is an object of the invention to enable multiple services or service providers to share the facilities of an access network infrastructure providing physical connectivity to subscribers. A network access device advantageously may be used in communication network services with a service or service provider that is separate from the operator of the access network infrastructure.

WO 01/71982 A1

SERVICE SELECTION IN A SHARED ACCESS NETWORK USING POLICY ROUTING

Field of the Invention

5 The present invention relates generally to communication network services, and, more particularly, to providing multiple services in a communication network.

Background of the Invention

10 Customers of communication network services often desire access to a plurality of different services and different service providers. For example, when using a dial-up connection to a packet-switched data network such as the Internet, a customer can choose from multiple service providers by dialing different telephone numbers in the PSTN. The physical path from the customer to
15 the customer's Internet Service Provider (ISP) is dedicated to the connection for the duration of the telephone call. The ISP assigns an IP address to the customer and can link the authenticated customer and the assigned IP address to the physical address (e.g. dial-up modem) used by the customer. With this linkage, the ISP can ensure the customer only uses the address authorized by the ISP and
20 can use the customer's IP address to manage access to the ISP's services. The physical connection between a customer and the ISP, as well as the linkage to IP address assignment and customer authentication is terminated when the dial-up connection is terminated.

 Constrained by the physical capacity of these temporary
25 connections across the PSTN, many service providers are moving to high-speed access architectures (e.g., digital subscriber line (DSL), wireless, satellite, or cable) that provide dedicated physical connectivity directly to the subscriber and under the control of the ISP. These alternatives to shared access through the switched telephone network, however, do not lend themselves to shared access by
30 multiple services and/or service providers.

Summary of the Invention

It is an object of the invention to enable multiple services or service providers to share the facilities of an access network infrastructure providing physical connectivity to subscribers. In accordance with an embodiment of the invention, a router situated at an edge of an access network forwards packets to any of a plurality of packet-switched service networks. The router uses a policy based on the source address of the packets to determine to which service network to forward the packet. Each network access device is assigned a network address, which is associated with a particular service or service provider to which the user of the device is subscribed. The network access device advantageously may be used in communication network services with a service or service provider that is separate from the operator of the access network infrastructure.

In accordance with another aspect of the invention, interconnections between a plurality of packet-switched service networks and an access network are localized into managed access points. Routers in the access network can advantageously forward packets to the managed access points using conventional routing procedures, thus enabling the access network to provide “local” packet-switched services. The managed access points use source address-based policy to determine to which service network to forward a packet. Where a packet arrives at a managed access point that is not connected to the correct service network, the managed access point can use packet encapsulation or some other form of tunneling to redirect the packet to the correct managed access point. The present invention, among other advantages, does not require interconnection points to each service network at every regional access network site.

These and other advantages of the invention will be apparent to those of ordinary skill in the art by reference to the following detailed description and the accompanying drawings.

Brief Description of the Drawings

FIG. 1 illustrates an interconnection of packet-switched service networks and an access network embodying principles of the invention.

65 FIG. 2A and FIG. 2B is conceptual representation of an example embodiment illustrating principles of the invention based on an HFC access architecture with corresponding end-to-end protocol layers.

FIG. 3 is a flowchart of processing performed at a policy router, in accordance with an embodiment of the invention.

FIG. 4 is a simplified example of router configuration instructions.

70 FIG. 5 illustrates an interconnection of packet-switched service network, regional access networks, and a packet-switched access network, embodying principles of another aspect of the invention.

75 FIG. 6 is a flowchart of processing performed at a policy router acting as a managed access point, in accordance with another embodiment of the invention.

Detailed Description

In FIG. 1, a plurality of subscribers operating network access devices 101, 102, 103, ... 104 are provided access to communication network services, which are facilitated by a plurality of packet-switched data networks, 80 shown in FIG. 1 as 151 and 152. Packet-switched data networks 151 and 152, referred to herein as "service networks," offer access to different services and/or are operated by different service providers. For example, service network 151 could provide packet-switched connectivity to public data networks while service 85 network 152 could offer packet-switched telephony service (or the same public data network connectivity, but from a different service provider). The service networks, as is well known in the art, utilize a network addressing scheme to route datagrams to and from hosts: for example, where the service networks utilize the TCP/IP protocol suite, Internet Protocol (IP) addresses are assigned to each host 90 and utilized in the process of routing packets from a source to a destination in the networks. See, e.g., "INTERNET PROTOCOL," IETF Network Working Group,

RFC 791 (September 1981); S. Deering, R. Hinden, ,“Internet Protocol, Version 6 (IPv6) Specification,” IETF Network Working Group, RFC 1883 (December 1995), which are incorporated by reference herein. The invention shall be
95 described herein with particular reference to the TCP/IP protocol suite and IP addresses, although those skilled in the art would readily be able to implement the invention using any of a number of different communication protocols.

The network access devices 101 ... 104 are typically customer premises equipment (CPE) such as a personal computer, information appliance,
100 personal data assistant, data-enabled wireless handset, or any other type of device capable of accessing information through a packet-switched data network. Each network access device 101 ... 104 is either connected to or integrated with a network interface unit 111 ... 114, e.g. a modem, which enables communication through an access network infrastructure, shown as 120 in FIG. 1. Each network
105 access device is assigned an IP address which, in accordance with an aspect of the invention, is associated with a particular service or service provider to which the user of the device is subscribed. For example, network access device 101 is assumed to have been assigned, for purposes of the description herein, an IP address associated with a service provider operating service network 151. As
110 further described herein, it is advantageous to provide a service activation system 160 which advantageously permits the dynamic allocation, assignment, and reassignment of IP addresses to the plurality of network access devices based on customer subscriptions to particular services.

The network access device 101 communicates with the service
115 network 151 through the access network infrastructure 120, which, in accordance with aspects of the invention, is capable of recognizing and directing traffic to the proper service network. The access network infrastructure 120 advantageously can be operated and maintained by an entity that is the same as or different from the entities operating and maintaining the service networks 151 and 152. In
120 accordance with an embodiment of an aspect of the present invention, the different IP-based services offered by the different service networks 151 and 152 utilize shared layer one and layer two resources in the access network 120. Layer

three routing procedures, however, are modified to permit IP traffic from network access device 101 to flow to the correct subscribed service network 151. The
125 access network 120 has a router 130 on the edge of the access network. The router 130 has a first interface with a connection to a router 141 in service network 151 and a second interface with a connection to a router 142 in service network 152. As further described herein, the router processes packets and is capable of directing traffic to the proper service network.

130 FIG. 2A shows an exemplary access architecture based on a hybrid fiber coaxial (HFC) access network. As is known in the art, each network interface device 201 ... 202 is either connected to or integrated with a cable modem 211 which enables communication through the HFC network 221. In accordance with the Data Over Cable Service Interface Specification (DOCSIS), a
135 Cable Modem Termination System (CMTS), shown as 225 in FIG. 2A, communicates with the cable modems 211 and manages access to both upstream and downstream cable capacity on the HFC networks 221. See, e.g., "Data-Over-Cable Service Interface Specifications: Cable Modem Termination System – Network Side Interface Specification," Cable Television Laboratories, Inc., SP-CMTS-NSI-I01-960702; "Data-Over-Cable Service Interface Specifications: Cable Modem to Customer Premise Equipment Interface Specification," Cable
140 Television Laboratories, Inc., SP-CMCI-C02C-991015; "Data-Over-Cable Service Interface Specifications: Baseline Privacy Plus Interface Specifications," Cable Television Laboratories, Inc., SP-BPI+-I06-001215, which are incorporated
145 by reference herein. The CMTS 225 manages the scheduling of both upstream and downstream transmission and allocates cable capacity to individual customers identified by a Service IDs (SIDs). The CMTS 225 can have an integrated router 228 or can be a separate device 226 that bridges to a fast Ethernet switch 227 which connects to the router 228. The IP router 228 provides connectivity to an
150 IP network 222, which further comprises the router 230 (corresponding to router 130 in FIG. 1) which interfaces to IP routers 241 and 242 in service networks 251 and 252, respectively. Accordingly, the HFC network 221, the CMTS 225, and the IP network 222 correspond to the access network infrastructure 120 shown in

FIG. 1. FIG. 2B shows a conceptual diagram of the end-to-end communication
155 protocol stack from a network access device 201 (101) to a router 241 (141) in
service provider's network 251 (151). As is known in the art, the lowest layer
deals with the physical layer (PL) of the protocol stack, e.g. the Ethernet physical
media device (PMD) layer; the second layer deals with the data link layer, e.g. the
Ethernet Media Access Control (MAC) layer; and the third layer in the protocol
160 stack deals with the network layer, e.g. the IP layer. The following aspects of the
invention deal with modifications to routing processes in the network layer of the
protocol stack.

Router 130 in the access network 120 in FIG. 1 (corresponding to
IP router 230 in FIG. 2) separates the IP traffic to the multiple services or service
165 providers as well as combines traffic from the multiple services or service
providers. In accordance with an aspect of the invention, IP packets are routed
from network access device 101 to the subscribed service network 151 using
source address-based policy routing. Conventional routing is destination-based:
the router consults an internal routing table which maps the destination addresses
170 of all inbound packets to a physical interface address for use for outgoing packets.
Policy routing schemes, however, will selectively choose different paths for
different packets even where the packet's destination address may be the same.
Since network access devices are assigned addresses associated with a particular
network service provider, the source address based policy routing scheme ensures
175 packets from a network access device will go to the appropriate service network.
Conventional destination-based routing will ensure that packets addressed to a
network access device will be routed to the appropriate service network. Note
that this would require service providers to advertise their service address ranges
to their peers.

180 FIG. 3 sets forth the processing performed at a router in the access
network, e.g. router 130 in FIG. 1. At step 301, the router receives an incoming
packet. At step 302, the router reads the packet header and retrieves the packet
filtering rules, typically stored in an access list as further described below. At
steps 303, 305, and 307, the router applies the packet filtering rules. At step 303,

185 the router compares the source IP address in the packet header to a list of
addresses allocated to subscribers of services of a first service provider, e.g.
operating service network 151 in FIG. 1. If the source address matches one of
these addresses, then at step 304 the router forwards the packet to a router in
service network 151, e.g. router 141 in FIG. 1. At step 305, the router compares
190 the source IP address in the packet header to a list of addresses allocated to
subscribers of services of a second service provider, e.g. operating service
network 152 in FIG. 1. If the source IP address matches one of these addresses,
then at step 305 the router forwards the packet to a router in service network 152,
e.g. router 142 in FIG. 1. The router continues in this fashion with any other
195 packet filtering rules identifying IP addresses allocated to subscribers of any other
service providers. Assuming the IP source address does not match any such
addresses associated with a service provider, at step 307, the router applies any
remaining packet filtering rules and routes or denies the packet accordingly.

FIG. 4 sets forth an example of router configuration instructions
200 written for the Cisco Internetworking Operating System (IOS), which is used
pervasively on conventional IP routers. Only the relevant portions of the
configuration instructions are shown. Lines 401 to 405 configure the interface to
utilize policy routing. Lines 406 to 410 specify the particular policy, namely to
set the next "hop" address to the router address of a router in a one of the service
205 networks, i.e. "isp1_next-hop_address," if the source address matches a
range of addresses allocated to subscribers of the services provided by the service
network, i.e. "isp1_subs." Lines 412 to 413 set forth access lists associating
"isp1_subs" with ranges of addresses expressed, by convention, as a source
address and a mask portion, i.e., the above policy is applied by the router to any
210 traffic with a subscriber source address expressed as "isp1_prefix1" with a
mask portion of "isp1_prefix1_wildcard".

The embodiment shown in FIG. 1 notably requires interconnection
points to all relevant service networks at each edge of each regional access
network. In accordance with another aspect of the invention, it is desirable to
215 create a regional transport network of routers and to localize the interconnection

between the service networks and the access infrastructure into managed access points. A managed access point is a physical location at which the interfaces to the service networks can be provided. Having one or a small plurality of managed access points advantageously allows service selection to be implemented without
220 requiring network service providers to connect physical facilities into, for example, every cable head end in an HFC-based network—thereby reducing costs for both the access network infrastructure operator and the service network providers. Each router in the regional transport network can be configured with policy information and invoke source address routing to forward packets to the
225 managed access point providing access to the relevant service network. By overriding normal routing procedures, however, these procedures may introduce potential routing loops absent significant coordination between the routers external to known routing protocols. This risk can be minimized by centralizing the policy routing function in a single router that provides the interfaces to the
230 service networks.

FIG. 5 illustrates an embodiment of this aspect of the invention. Each network access device 501 is connected through a network interface unit 511 to one of a plurality of access networks, e.g. 521 and 522 in FIG. 5. Each access network has an edge router (531 and 532 respectively in FIG. 5) which connects
235 the access network to a regional IP network of routers, represented abstractly in FIG. 5 as IP access network 570. It is advantageous to aggregate connections from groups of edge routers to a single aggregation router 571 in the IP access network 570, as shown in FIG. 5. Aggregation router 571 can then connect to other routers in the regional IP network 570, i.e. routers 572 ... 573, which can
240 also be aggregation routers connecting to pluralities of edge routers. Routers 541, 542, ... 543 in service networks 551, 552, ... 553 connect to the IP network 570 at routers 574 and 575, which act as managed access points to the service networks. Only the managed access point routers, e.g. 575, need invoke policy routing based on packet source address. All intermediate routers within the IP access network
245 570, i.e. 571 ... 573, use normal destination-based forwarding procedures for

destinations that are not local to the network 570. No configuration of policy in the intermediate routers is necessary.

By locating the policy routing functions at the interfaces to the service networks, the access network infrastructure (whether reflected generally
250 by 120 in FIG. 1 or, in the packet-switched context, as network 570 in FIG. 5) can provide access to “local” services available from within the access network infrastructure. For example, IP network 570 can provide access to “local” packet-switched services and operate independent of the source address assigned to the network access devices. Since the intermediate routers 571 ... 573 all use
255 conventional destination-based forwarding, network 570 will properly route local service packets along the correct routing paths. “Non-local” service packets, however, are routed towards the managed access point routers 575 and 574 and policy routed to the correct service network. Where the network 570 forwards to a single managed access point router or where each managed access point router
260 has a connection to each service network, the managed access point router can forward packets in accordance with the policies described above. Where, however, there are service networks that connect to only a subset of the managed access points (e.g., in FIG. 5, where service network 553 only connects to managed access point router 574), packets can be redirected or “tunneled” to the
265 correct managed access point in order to ensure that the packets arrive at the correct service network. The multiple interconnected managed access points can then provide a single “logical” inter-domain gateway, again permitting all other routers to use conventional destination-based routing procedures.

FIG. 6 sets forth a flowchart of the processing performed at a
270 managed access point router, e.g. router 575 in FIG. 5, illustrating an embodiment of this aspect of the invention. The particular managed access point router 575 is assumed to be connected to two service networks, e.g. service networks 551 and 552 in FIG. 5, while a second managed access point router 574 provides access to a third service network, service network 553. At step 601, the router receives an
275 incoming packet. At step 602, the router reads the packet header and retrieves the packet filtering rules, as well as decapsulates any encapsulated packets, as further

described herein. At steps 603, 605, 607, and 609, the router applies the packet filtering rules. At step 603, the router compares the source IP address in the packet header to a list of addresses allocated to subscribers of services of a first service provider, e.g. operating service network 551 in FIG. 5. If the source address matches one of these addresses, then at step 604 the router forwards the packet to a router in service network 551, e.g. router 541 in FIG. 5. At step 605, the router compares the source IP address in the packet header to a list of addresses allocated to subscribers of services of a second service provider, e.g. operating service network 552 in FIG. 5. If the source IP address matches one of these addresses, then at step 606 the router forwards the packet to a router in service network 552, e.g. router 542 in FIG. 5. At step 607, the router compares the source IP address in the packet header to a list of addresses allocated to subscribers of services of a third service provider, e.g. operating service network 553 in FIG. 5, which is not connected to this particular managed access point. If the source IP address matches one of these addresses, then at step 608, the router encapsulates the packet, using any of a number of known methods for packet encapsulation, and routes the packet to a new destination address, namely the address of the managed access point with access to service network 553, i.e. managed access point router 574. Packet encapsulation is a method by which a packet may rerouted to an intermediate destination other than the destination that would be selected using normal routing procedures. See, e.g., C. Perkins, "IP Encapsulation within IP," IETF Network Working Group, RFC 2003 (October 1996); C. Perkins, "Minimal Encapsulation within IP," IETF Network Working Group, RFC 2004 (October 1996), which are incorporated by reference herein. The receiving router 574 will decapsulate the packet and route the packet, accordingly, to service network 553. The router continues in this fashion with any other packet filtering rules identifying IP addresses associated with any other service providers. Assuming the IP source address does not match any addresses associated with any other service providers, at step 609, the router applies any remaining packet filtering rules and routes or denies the packet accordingly. Note that if managed access point 575 has a direct physical connection to managed

access point 574, then no encapsulation is needed. In fact, a typical configuration might include multiple port-constrained policy routers on a GIG Ethernet
310 providing the logical managed access point function without any encapsulation. Encapsulation is only really needed to provide a logical direct connection if there is not a direct physical connection.

Packets traveling between network access devices connected to the same access network infrastructure can be forwarded directly between the devices
315 in the access network – rather than forwarding the packets outwards to a service network and back to the same access network. This advantageously saves on bandwidth and other network resources. The only packets that need be routed to a managed access point router need be the ones for which no specific route is known internally to the access network infrastructure.

320 The foregoing Detailed Description is to be understood as being in every respect illustrative and exemplary, but not restrictive, and the scope of the invention disclosed herein is not to be determined from the Detailed Description, but rather from the claims as interpreted according to the full breadth permitted by the patent laws. It is to be understood that the embodiments shown and described
325 herein are only illustrative of the principles of the present invention and that various modifications may be implemented by those skilled in the art without departing from the scope and spirit of the invention. For example, the detailed description describes an embodiment of the invention with particular reference to an HFC access network architecture. However, the principles of the present
330 invention could be readily extended to other access network architectures, such as DSL, wireless, satellite, etc. Such an extension could be readily implemented by one of ordinary skill in the art given the above disclosure.

What is claimed is:

- 1 1. A method of operating a router in an access network
2 infrastructure connected to a plurality of service networks, comprising the steps
3 of:
4 receiving an incoming packet with a source address;
5 comparing the source address of the incoming packet to network
6 addresses allocated to subscribers of services provided by a service network; and
7 if the source address matches a network address allocated to
8 subscribers of services provided by the service network, forwarding the packet to
9 a router in the service network.
- 1 2. The invention of claim 1 wherein the source address of the
2 incoming packet is assigned to a network access device associated with the
3 subscriber of services provided by the service network.
- 1 3. The invention of claim 1 wherein the service networks utilize
2 the Internet Protocol and wherein the addresses are Internet Protocol addresses.
- 1 4. The invention of claim 3 wherein the plurality of service
2 networks are operated by different Internet Service Providers.
- 1 5. The invention of claim 3 wherein the plurality of service
2 networks offer access to different Internet Protocol-based services.
- 1 6. The invention of claim 3 wherein the access network
2 infrastructure comprises a hybrid fiber coaxial network.
- 1 7. The invention of claim 6 wherein the source address of the
2 incoming packet identifies a network access device attached to the hybrid fiber
3 coaxial network with a cable modem.

1 8. A method of operating an access network infrastructure
2 comprising a plurality of routers and connected to a plurality of service networks,
3 comprising the steps of:

4 using destination-based routing at the routers in the access network
5 infrastructure except at one or more managed access point routers having
6 connections to routers in the plurality of service networks;

7 using policy-based routing at the managed access point routers so
8 that packets having a source address allocated to subscribers of services provided
9 by a service network will be forwarded to a router in the service network.

1 9. The invention of claim 8 wherein packets between network
2 access devices connected to the access network infrastructure are routed in the
3 access network infrastructure using destination-based routing without being
4 forwarded to a service network.

1 10. The invention of claim 8 wherein the access network
2 infrastructure provides access to local services.

1 11. The invention of claim 10 wherein packets associated with the
2 local services are routed in the access network infrastructure using destination-
3 based routing without being forwarded to a service network.

1 12. The invention of claim 8 wherein the source address of the
2 incoming packet is assigned to a network access device associated with the
3 subscriber of services provided by the service network.

1 13. The invention of claim 8 wherein the service networks utilize
2 the Internet Protocol and wherein the addresses are Internet Protocol addresses.

1 14. The invention of claim 13 wherein the plurality of service
2 networks are operated by different Internet Service Providers.

1 15. The invention of claim 13 wherein the plurality of service
2 networks offer access to different Internet Protocol-based services.

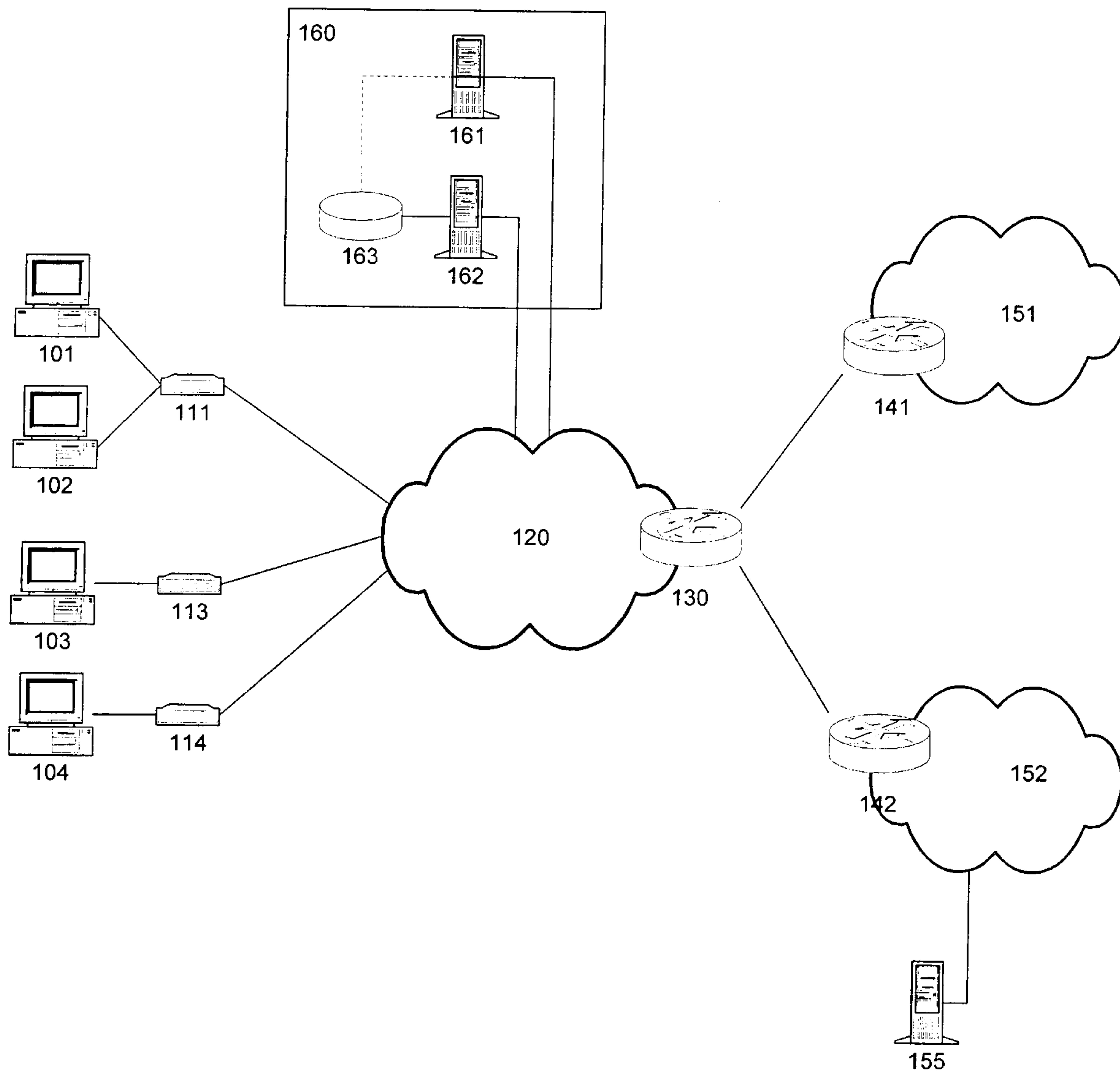

FIG. 1

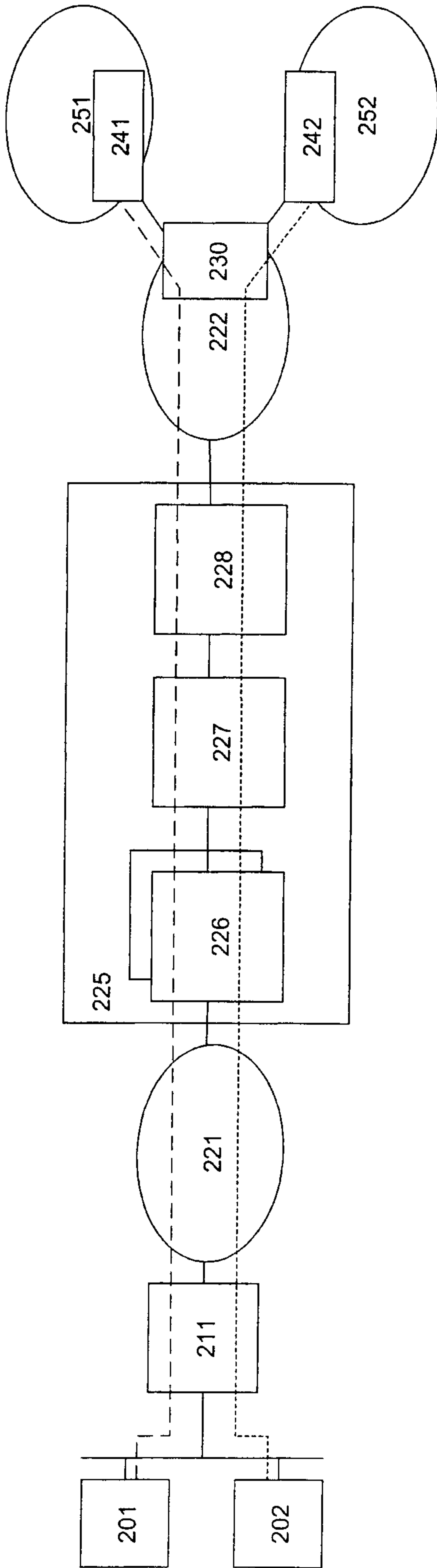

FIG. 2A

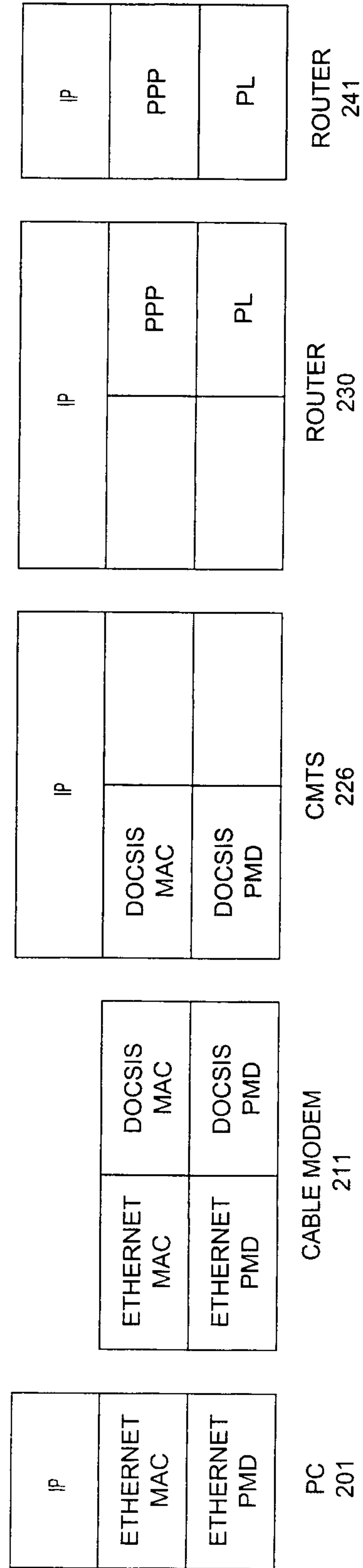

FIG. 2B

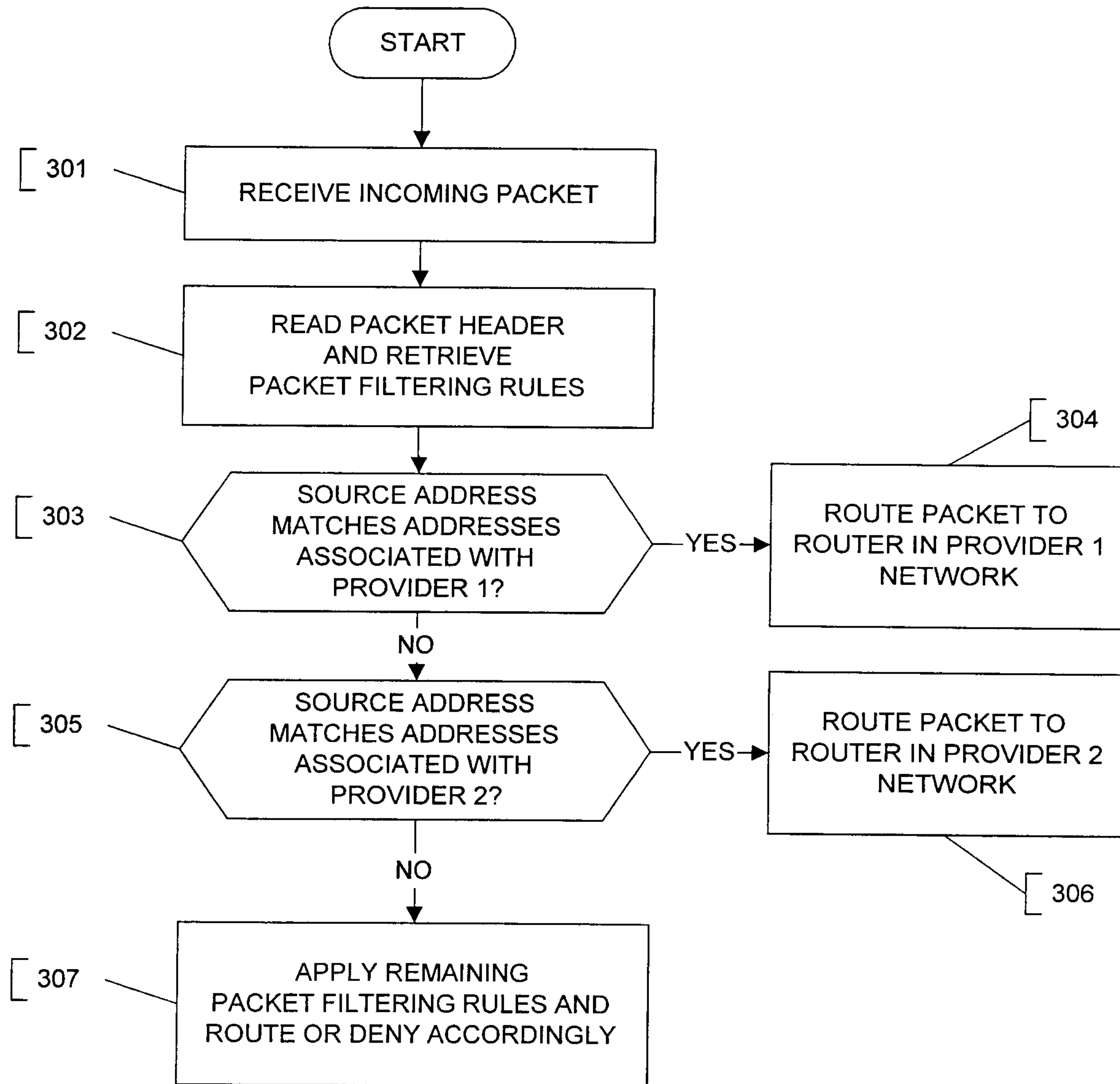

FIG. 3

```
401 interface cable x/y
402 ...
403 ip policy route-map source_route
404 ...
405 !

406 route-map source_route
407 match ip address isp1_subs
408 set ip next-hop isp1_next-hop_address
409 match ip address isp2_subs
410 set ip next-hop isp2_next-hop_address
411 ...
412 access-list isp1_subs permit isp1_prefix1
isp1_prefix1_wildcard any any
413 access-list isp1_subs permit isp1_prefix2
isp1_prefix2_wildcard any any
414 ...
```

FIG. 4

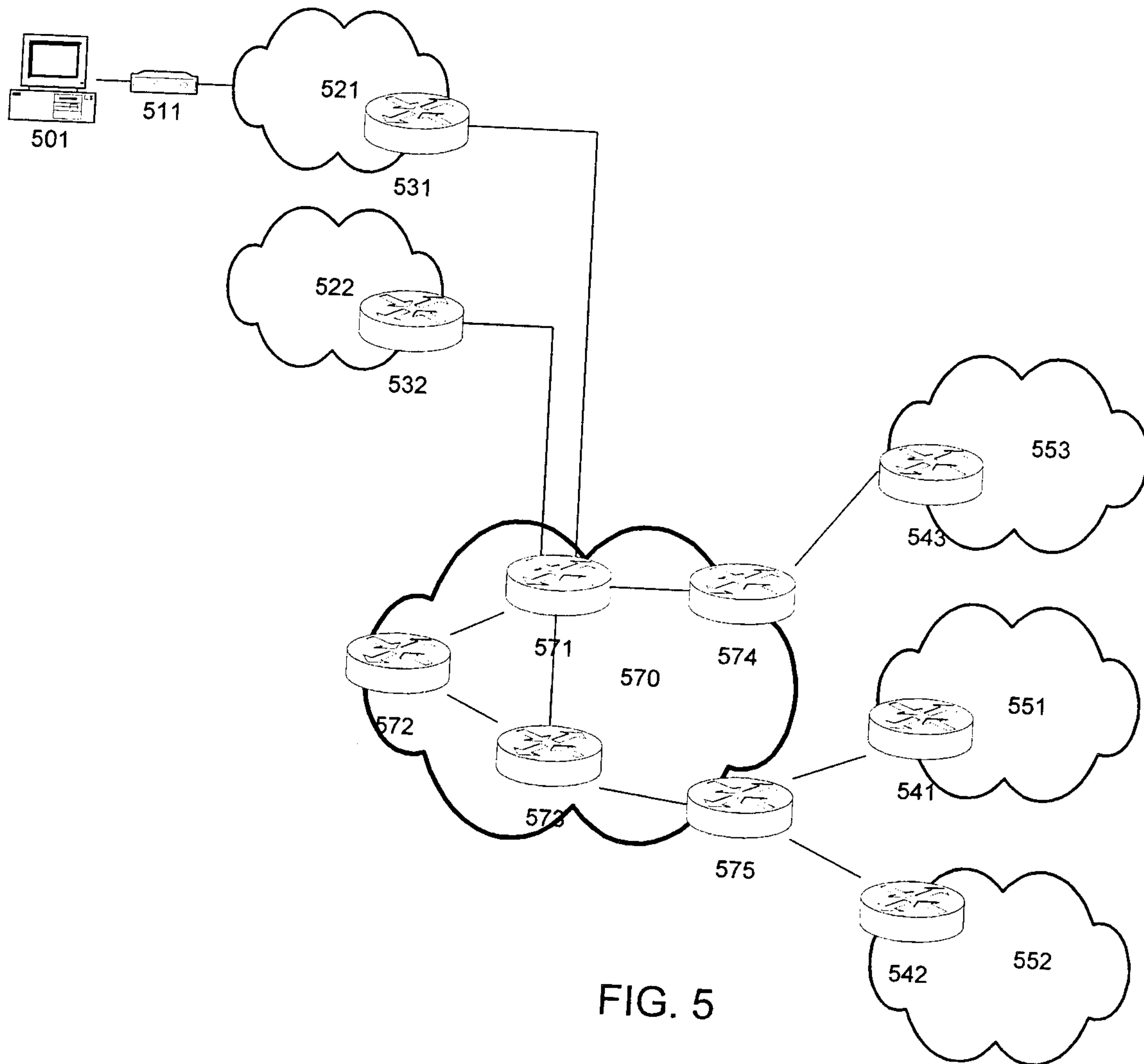

FIG. 5

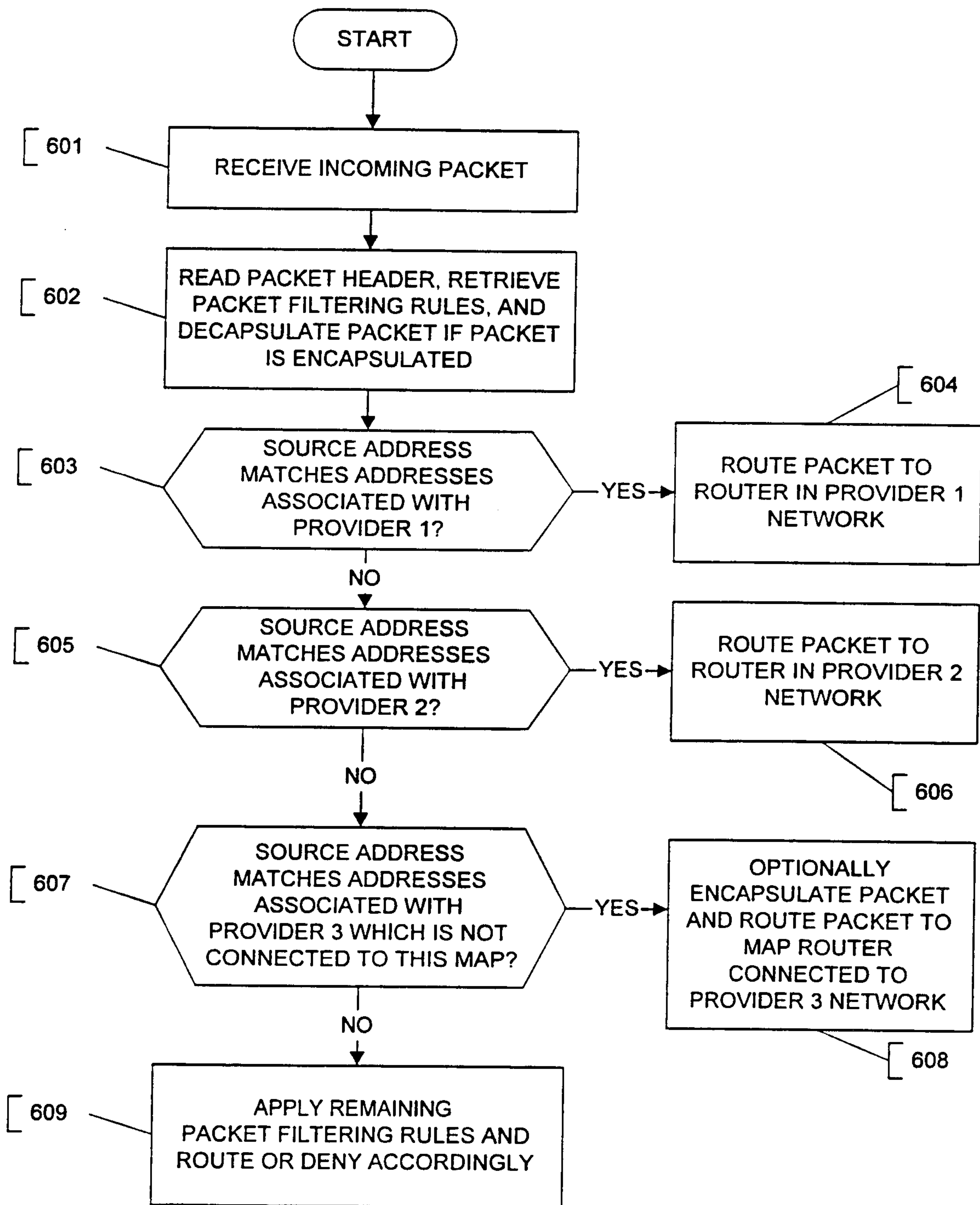

FIG. 6

