

Sheet 1, of 2 sheets.

B. Lapham. Loom.

No 575.

Patented Jan. 20, 1838.

Fig. 1.

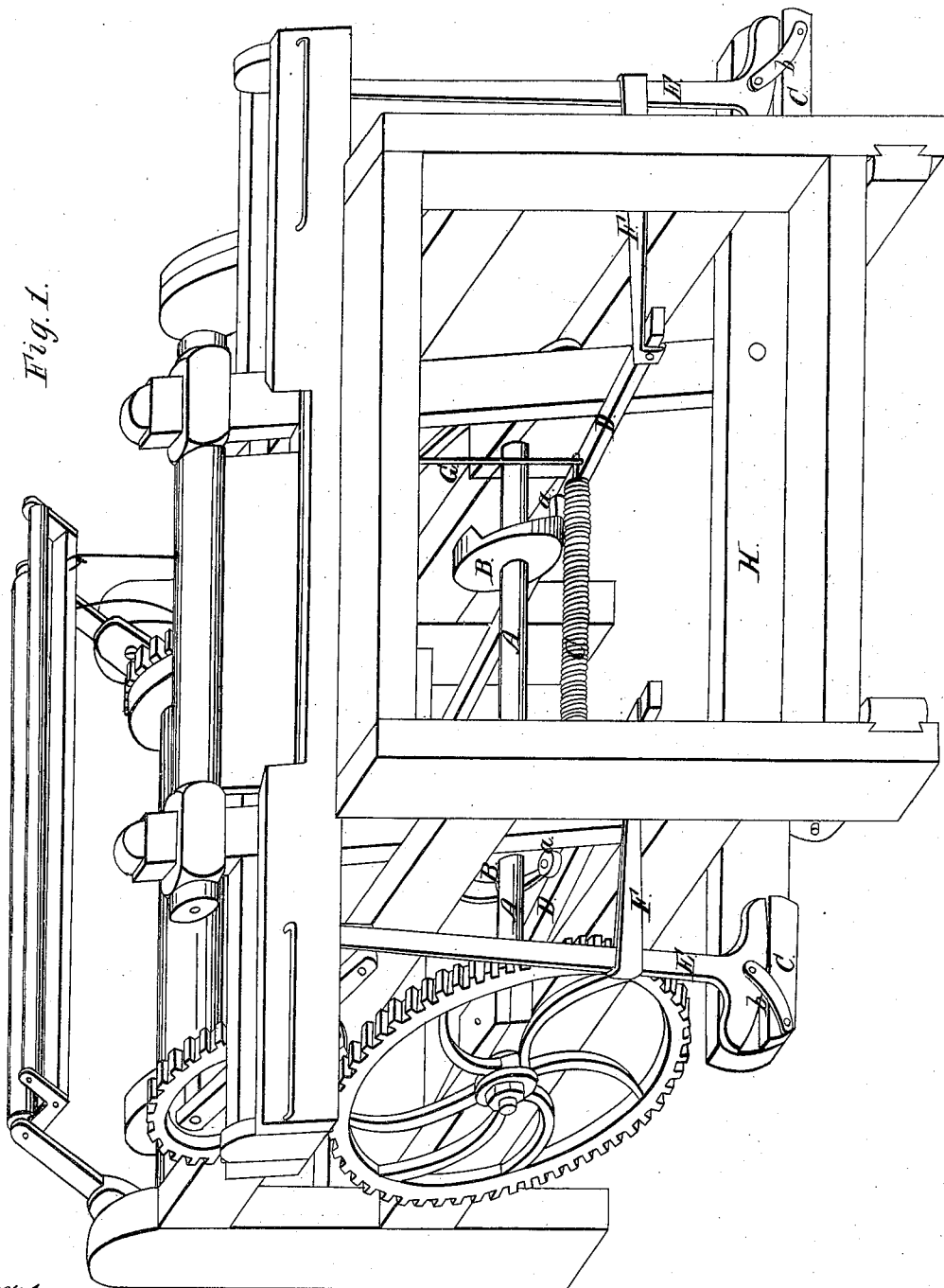

Witnesses.

J. Cramer 2;
Chas. S. S. W.
L. J. Bailey

Inventor.

Benjamin Lapham

Sheet 2, of 2 Sheets.

B. Lapham. Loom.

No 575.

Patented Jan 20, 1838.

Fig. 2

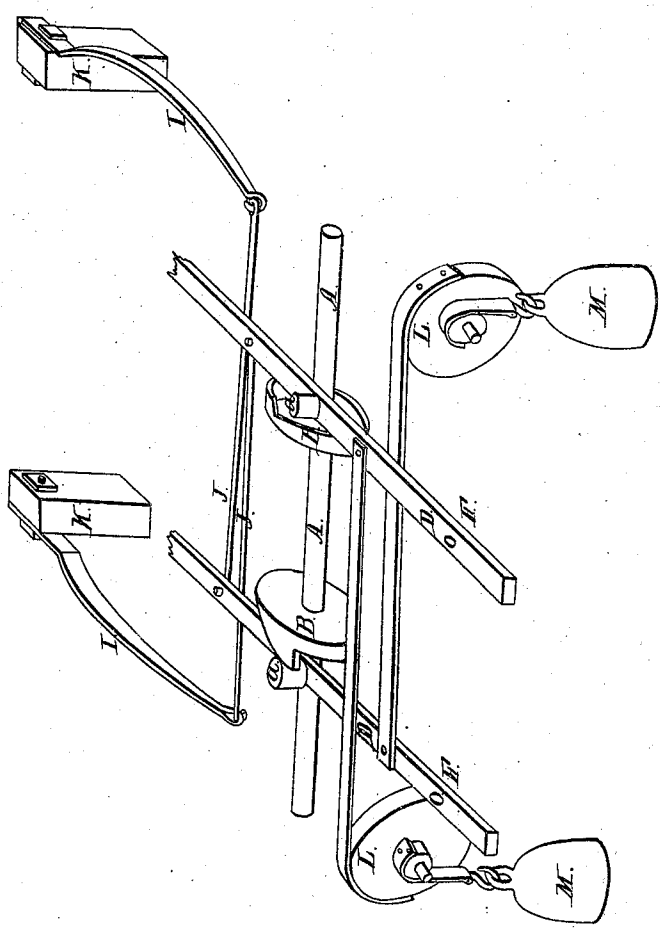

Witnesses.
 J. Cramer 2,
 Wm. S. S. S.,
 A. G. Bailey

Inventor.
 Benjamin Lapham

UNITED STATES PATENT OFFICE.

BENJAMIN LAPHAM, OF WATERFORD, NEW YORK.

COMMON AND POWER LOOM.

Specification of Letters Patent No. 575, dated January 20, 1838.

To all whom it may concern:

Be it known that I, BENJAMIN LAPHAM, of Waterford, in the county of Saratoga and State of New York, have invented a new and useful Improvement in Power and Common Looms; and I do hereby declare that the following is a full and exact description thereof, reference being had to the drawings annexed.

The nature of my invention consists in employing a spring to move the "wagstaff" in throwing the shuttle, and of dispensing with the ordinary "picker," "picker strings" and "picker rods" commonly used in the power loom; which I effect by straining a spring gradually during a full revolution of the cam shaft, by which the necessary force to throw the shuttle is acquired by an easy and uniform resistance to the driving power, exerting that force, always certain, under any speed of the loom.

I do not deem it necessary to describe, in detail, all the parts of the common or power loom to point out this improvement; I have therefore only marked the parts in the drawings which are new, and such other parts as are connected with them, which will be sufficiently clear and distinct to a person skilled in the art of building power looms.

Description: A and A, cam shaft, of ordinary speed 1 to 2 of the crank shaft; B and B, transverse cams, having a regular and gradual inclination transversely the whole circumference of the cam. The cams are set upon the shaft, so as to divide equally between both cams, alternately a throw of the shuttle at a half revolution of the shaft; C, spiral spring, made of No. 3 wire (less or more) and attached to the cam levers D D, and containing the deposit of power when strained to throw the shuttle; D and D, cam levers, working against the cams B and B by the friction rollers *a* and *a*; E and E, wagstaffs, the upper ends of which pass through the center mortises in the bottom of the shuttle boxes; upon the working side, the shuttle, is faced with rawhide, or other hard substance. The lower ends or feet of the wagstaffs describe a sweep or section of a circle, of such form as to produce a horizontal movement to that part of the upper end of it, which works against the shuttle, and is connected by a yoke *b* and *b* to the seat *c* and *c* affixed to the base board of the lathe; F and F, leather straps, (iron rods

may be used with equal advantage) connecting the cam levers with the wagstaffs; G, suspension rods, to sustain the cam levers D and D, working at the top by a joint on a stud thrown inward five inches, or thereabouts, and attached to the upper rail of the loom; H, base board, of the lathe upon which the rocker of the wagstaffs rests.

Figure 2 supplementary drawing, a skeleton description of two variations in the principle of action embraced in the declaration at the head of this description, stating the nature and design of my invention, and involving the same principle with the above first described method, viz: 1st, I and I are two strong springs fastened to the back parts of the frame of the loom K and K and are connected with the cam levers D and D by the connecting rods J and J; 2d, L and L are pulleys attached by stands to the inner or outward sides of the lower girt in the frame of the loom, to which the weights M and M are appended and connected by the straps N and N to the cam levers D and D. In either case the spiral spring C is dispensed with.

The mode of operation will be instantly perceived by a person skilled in the art of weaving or of loom building, and therefore does not require a particular explanation from me. The transverse cams bring a gradual incline during nearly a full revolution of the crank shaft—they acquire the force to throw the shuttle with great uniformity of resistance to the driving power, and not suddenly exerted as is the case with the old and common methods, and that force as will be seen will always be equal and the same under any speed of the loom when the weight is raised or the spring strained.

What I claim as new, and desire to secure by Letters Patent is—

1. The manner of applying the principle of gradually accumulating a deposit of power to throw the shuttle, whether it be by the use of straining a spring, or by raising a weight as herein described.

2. The particular device herein specified, taken and considered, as a combination of old methods, to produce a new result.

BENJAMIN LAPHAM.

Witnesses:

I. CRAMER, 2d,
O. H. LEE,
A. G. BAILEY.