



US00D672352S

(12) **United States Design Patent**
Gengler

(10) **Patent No.:** **US D672,352 S**

(45) **Date of Patent:** **** Dec. 11, 2012**

(54) **SUPPORT ELEMENT OF A PROTECTIVE COVER FOR A MOBILE COMPUTING DEVICE**

206/762; 455/575.3, 575.8, 575.1, 575.88; 379/433.11; 345/173

See application file for complete search history.

(75) Inventor: **David Gengler**, Draper, UT (US)

(56)

References Cited

(73) Assignee: **Zagg Intellectual Property Holding Co., Inc.**, Salt Lake City, UT (US)

U.S. PATENT DOCUMENTS

(**) Term: **14 Years**

(21) Appl. No.: **29/379,839**

(22) Filed: **Nov. 24, 2010**

Related U.S. Application Data

(63) Continuation-in-part of application No. 29/379,058, filed on Nov. 12, 2010, now Pat. No. Des. 659,139, which is a continuation-in-part of application No. 12/832,845, filed on Jul. 8, 2010, and a continuation-in-part of application No. 29/378,952, filed on Nov. 11, 2010.

(51) **LOC (9) Cl.** **14-02**

(52) **U.S. Cl.** **D14/440; D14/447**

(58) **Field of Classification Search** **D14/440,**

D14/447, 434, 375, 376, 432, 439, 451, 356, D14/316, 315, 317-335, 253, 448, 452, 457, D14/460, 461, 239, 250, 251, 217, 238.1; D6/300, 512, 310-314, 419, 572, 420, 406.3, D6/406.4, 406.5, 406.6; D19/86, 90-91, D19/88; 248/442.2, 918, 279.1, 284.1, 454, 248/457, 917, 65, 441.1, 455, 460, 923, 371, 248/447, 393, 398, 122.1, 127, 133, 136, 248/456, 461-464, 121, 126, 176.1, 205.3, 248/677, 683, 688, 445, 450, 453, 429, 176.3, 248/459, 300, 451, 919-924; 361/683, 686, 361/679.08, 679.02, 679.09, 679.21, 679.22, 361/379.26, 679.27-679.29, 679.3, 679.46-679.48, 361/679.55-679.59, 679.6, 679.01; 108/10, 108/28, 32, 6; 40/777, 743, 800, 124.01, 40/124.08, 124.16, 750, 754, 755; D21/392; D3/218; 150/165; 224/929, 930; 281/45, 281/31; 206/320, 45.23-45.28, 45.2, 751,

289,652	A *	12/1883	Haynes	248/451
649,293	A *	5/1900	French	248/456
756,486	A *	4/1904	Fleming	248/456
805,895	A *	11/1905	Wedderburn	273/150
1,169,869	A *	2/1916	Richards	248/453
1,203,659	A *	11/1916	Smith	248/456
1,308,010	A *	6/1919	Gibson	248/460
1,475,134	A *	11/1923	Oakes	248/468
1,499,113	A *	6/1924	McNally	206/0.815
1,588,618	A *	6/1926	Rosen	273/150
1,704,561	A *	3/1929	Egan	248/453
2,165,255	A *	7/1939	Hamilton	248/455
2,252,571	A *	8/1941	Kohn	248/459
2,373,617	A *	4/1945	Tiryakian	248/453
2,401,811	A *	6/1946	Atticks	248/460
2,726,835	A *	12/1955	Hummel	248/459
2,916,236	A *	12/1959	Cross et al.	248/459
2,920,409	A *	1/1960	Sampson	40/122
2,946,545	A *	7/1960	Sampson	248/459
3,125,356	A *	3/1964	Cline	281/33
3,195,850	A *	7/1965	Steiner	248/454
3,275,281	A *	9/1966	Sampson	248/465
3,367,679	A *	2/1968	Slanhoff	281/33
3,544,134	A *	12/1970	Sibley	281/33
3,758,065	A *	9/1973	Ranseen	248/459
3,785,605	A *	1/1974	Parekh	248/455
D243,977	S *	4/1977	Roberts	D18/12
4,044,980	A *	8/1977	Cummins	248/456
4,259,568	A *	3/1981	Dynesen	235/1 D
D264,032	S *	4/1982	Rule	D6/313
4,460,146	A *	7/1984	Raggiotti	248/456
D279,185	S *	6/1985	Felix et al.	D14/251
4,555,084	A *	11/1985	Anderson et al.	248/460
4,555,128	A *	11/1985	White et al.	281/45
4,575,037	A *	3/1986	Hammar	248/441.1
4,607,817	A *	8/1986	Aquino	248/459
D286,352	S *	10/1986	Huculak	D6/430
4,709,895	A *	12/1987	Mardak	248/460
4,722,504	A *	2/1988	Degenholtz	248/459
D297,073	S *	8/1988	Curci	D3/313
4,771,976	A *	9/1988	Su	248/448
D300,785	S *	4/1989	Sorge et al.	D3/313
D305,015	S *	12/1989	Roche	D12/133
4,886,231	A *	12/1989	Doerksen	248/455
4,887,724	A *	12/1989	Pielechowski et al.	211/11

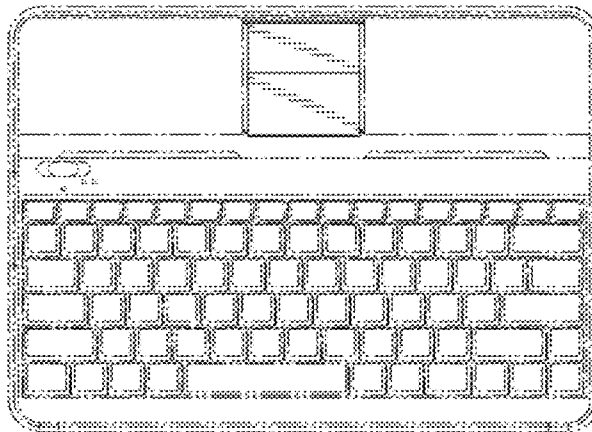
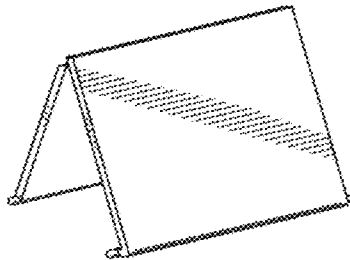

D308,497 S *	6/1990	Roche	D12/133	D635,191 S *	3/2011	Cheetwood	D19/91
4,991,812 A *	2/1991	MacEwan	248/459	D637,583 S *	5/2011	Beal et al.	D14/217
5,027,961 A *	7/1991	Howitt	211/188	D639,286 S *	6/2011	Mohoney	D14/250
D319,472 S *	8/1991	Clyburn	D19/92	D639,296 S *	6/2011	Tseng et al.	D14/345
D328,314 S *	7/1992	MacEwan	D19/91	D639,816 S *	6/2011	Bau	D14/447
D328,985 S *	9/1992	Sheldon	D6/406.4	D640,708 S *	6/2011	Lee	D14/447
D333,574 S *	3/1993	Ackeret	D6/300	D641,177 S *	7/2011	Chamberlain	D6/310
5,213,302 A *	5/1993	Rowe, Jr.	248/459	8,004,834 B2 *	8/2011	Shih et al.	361/679.55
5,263,668 A *	11/1993	Reiter	248/346.01	8,023,256 B2 *	9/2011	Walker et al.	361/679.27
D344,197 S *	2/1994	Numbers	D6/419	D646,903 S *	10/2011	Santana	D6/310
5,337,985 A *	8/1994	Hale	248/174	D646,904 S *	10/2011	Feldstein et al.	D6/310
5,458,242 A *	10/1995	Baka et al.	206/488	D648,529 S *	11/2011	Brown	D3/269
5,485,980 A *	1/1996	Luccia	248/445	D648,728 S *	11/2011	Atkins et al.	D14/447
5,620,163 A *	4/1997	Wu	248/688	8,100,376 B2 *	1/2012	Ye	248/454
D382,300 S *	8/1997	Thorne et al.	D19/91	D656,500 S *	3/2012	Maruyama et al.	D14/447
D388,263 S *	12/1997	Amerault	D6/419	8,173,893 B2 *	5/2012	Huang	136/251
D395,640 S *	6/1998	Goodman et al.	D14/447	D661,693 S *	6/2012	Andre et al.	D14/315
5,871,189 A *	2/1999	Hoftman	248/229.16	D664,528 S *	7/2012	Chen et al.	D14/253
D411,767 S *	7/1999	Keller	D3/273	D666,174 S *	8/2012	Du et al.	D14/217
5,927,673 A *	7/1999	Kurokawa et al.	248/456	D666,614 S *	9/2012	Ding	D14/253
D413,872 S *	9/1999	Jessen	D14/447	2002/0088918 A1 *	7/2002	Uto et al.	248/688
6,003,831 A *	12/1999	Coleman	248/688	2002/0162935 A1 *	11/2002	Hardy	248/460
6,082,696 A *	7/2000	Patterson	248/454	2003/0090865 A1 *	5/2003	Silverstein	361/683
6,113,052 A *	9/2000	Gentile et al.	248/456	2003/0217497 A1 *	11/2003	Nagel	40/661
6,129,323 A *	10/2000	Mandokoro et al.	248/453	2004/0007649 A1 *	1/2004	Vettraiño	248/127
D437,709 S *	2/2001	Edstrom	D6/406.4	2005/0200608 A1 *	9/2005	Ulla et al.	345/168
6,186,343 B1 *	2/2001	Brown	211/40	2005/0205623 A1 *	9/2005	Buntain	224/217
6,231,023 B1 *	5/2001	Morton	248/441.1	2005/0263666 A1 *	12/2005	Kim	248/445
D443,999 S *	6/2001	Cable	D6/406.4	2006/0249646 A1 *	11/2006	Al-Haleem	248/459
6,256,193 B1 *	7/2001	Janik et al.	361/679.59	2010/0122924 A1 *	5/2010	Andrews	206/320
6,270,049 B1 *	8/2001	Olvey	248/441.1	2011/0024371 A1 *	2/2011	Lampman et al.	211/4
6,293,591 B1 *	9/2001	Pecci	281/33	2011/0031287 A1 *	2/2011	Le Gette et al.	224/101
6,480,373 B1 *	11/2002	Landry et al.	361/679.06	2011/0168864 A1 *	7/2011	Marchione	248/447.1
6,487,068 B1 *	11/2002	Rahemtulla	361/679.04	2011/0259788 A1 *	10/2011	Zeliff et al.	206/701
6,568,543 B1 *	5/2003	Schneider	211/43	2012/0037047 A1 *	2/2012	Moldovan	108/3
6,735,698 B1 *	5/2004	Callam	726/35	2012/0074271 A1 *	3/2012	Goetz	248/121
6,772,879 B1 *	8/2004	Domotor	206/45.23	2012/0170194 A1 *	7/2012	Lord et al.	361/679.02
6,778,196 B2 *	8/2004	Nakamura	361/679.27	2012/0199501 A1 *	8/2012	Le Gette et al.	206/45.24
D510,517 S *	10/2005	Noack	D8/373	2012/0211377 A1 *	8/2012	Sajid	206/216
D513,008 S *	12/2005	Takizawa et al.	D14/447				
6,971,622 B2 *	12/2005	Ziegler et al.	248/454				
6,975,507 B2 *	12/2005	Wang et al.	361/679.21				
D517,328 S *	3/2006	Thrall	D6/300				
7,090,074 B2 *	8/2006	Isaacs	206/214				
7,104,516 B2 *	9/2006	Uto et al.	248/688				
7,123,471 B2 *	10/2006	Wang et al.	361/679.09				
D534,730 S *	1/2007	Hardy	D6/312				
D540,859 S *	4/2007	Weiler	D19/34.1				
7,287,751 B2 *	10/2007	Webber, Jr.	273/239				
D555,163 S *	11/2007	Beilstein et al.	D14/451				
D557,259 S *	12/2007	Hirsch	D14/217				
D557,267 S *	12/2007	Beilstein et al.	D14/451				
D557,495 S *	12/2007	Chan et al.	D3/218				
D557,698 S *	12/2007	Lye	D14/447				
7,318,521 B2 *	1/2008	Lau	206/45.24				
D563,093 S *	3/2008	Nussberger	D3/201				
D567,630 S *	4/2008	Brassard	D8/349				
D567,631 S *	4/2008	Brassard	D8/349				
D569,380 S *	5/2008	Beilstein et al.	D14/447				
D592,188 S *	5/2009	Huang	D14/217				
7,527,235 B2 *	5/2009	Hummel	248/459				
7,537,192 B2 *	5/2009	Al-Haleem et al.	248/459				
7,540,466 B2 *	6/2009	Yang	248/688				
D600,748 S *	9/2009	Tabuchi et al.	D19/35				
7,584,841 B2 *	9/2009	Chan et al.	206/45.23				
7,630,745 B2 *	12/2009	Chen et al.	455/575.8				
D611,544 S *	3/2010	Liptan	D19/88				
D615,079 S *	5/2010	Masuyama et al.	D14/315				
D616,433 S *	5/2010	Morishita et al.	D14/315				
D616,700 S *	6/2010	Pourounidis et al.	D7/388				
7,735,644 B2 *	6/2010	Sirichai et al.	206/320				
D621,839 S *	8/2010	Sweet	D14/434				
7,775,356 B2 *	8/2010	Palmer	206/320				
D624,532 S *	9/2010	Huskinson	D14/250				
D624,908 S *	10/2010	Huskinson	D14/250				
D626,129 S *	10/2010	Lutz	D14/447				
7,828,260 B2 *	11/2010	Hauser et al.	248/456				
7,845,612 B2 *	12/2010	Mase	248/455				
7,861,995 B2 *	1/2011	Liou	248/454				

* cited by examiner

Primary Examiner — Susan Moon Lee

(74) Attorney, Agent, or Firm — Durham Jones & Pinegar, P.C. Intellectual Property Law Group

(57)

CLAIM

The ornamental design for a support element of a protective cover for a mobile computing device, as shown and described.

DESCRIPTION

FIG. 1 is a top perspective view of an embodiment of a design for a support element of a protective cover for a mobile computing device, showing the support element in a folded, or collapsed, position;

FIG. 2 is a bottom perspective view of the embodiment of support element in the position shown in FIG. 1;

FIG. 3 is a top view of the embodiment of support element in the position illustrated by FIGS. 1 and 2;

FIG. 4 is a bottom view of the embodiment of support element in the position depicted by FIGS. 1 through 3;

FIG. 5 is a front edge view of the embodiment of support element in the position illustrated by FIGS. 1 through 4;

FIG. 6 is a rear edge view of the embodiment of support element in the position shown in FIGS. 1 through 5;

FIG. 7 is a first side view of the embodiment of support element in the position depicted by FIGS. 1 through 6;

FIG. 8 is a second side view of the embodiment of support element in the position illustrated by FIGS. 1 through 7;

FIG. 9 is a frontal perspective view of the embodiment of support element shown in FIGS. 1 through 8, in a partially open, or upright, position;

FIG. 10 is a top view of the embodiment of support element illustrated by FIGS. 1 through 9, in the position depicted in FIG. 9;

FIG. 11 is a bottom view of the embodiment of support element shown in FIGS. 1 through 10, in the position illustrated by FIGS. 9 and 10;

FIG. 12 is a first side view of the embodiment of support element depicted by FIGS. 1 through 11 in the position shown in FIGS. 9 through 11;

FIG. 13 is a second side view of the embodiment of support element depicted by FIGS. 1 through 12 in the position illustrated by FIGS. 9 through 12;

FIG. 14 is a top view of the embodiment of support element illustrated by FIGS. 1 through 13, in the position depicted by FIGS. 1 through 8, showing the support element as part of an embodiment of a protective cover for a mobile computing device; and,

FIG. 15 is a top view of the embodiment of support element illustrated by FIGS. 1 through 13, in the position depicted by FIGS. 9 through 13, showing the support element as part of an embodiment of a protective cover for a mobile computing device.

Broken lines have been included in the drawings merely to illustrate examples of environments for the embodiment of design for the support element depicted in the drawings. The features that are illustrated by broken lines form no part of the claimed design.

The claimed design may be arranged in a plurality of positions and, therefore, is not limited to the positions illustrated by the drawings.

1 Claim, 2 Drawing Sheets

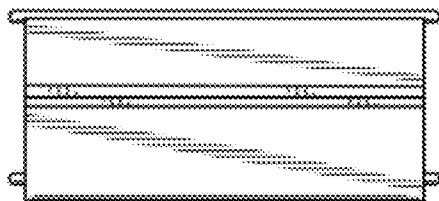
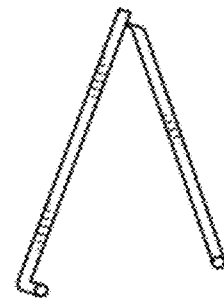
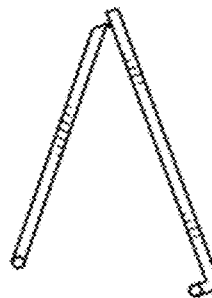
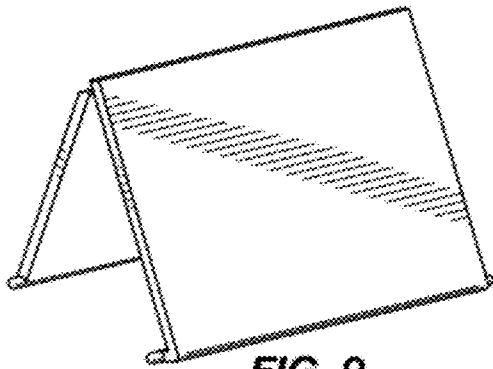
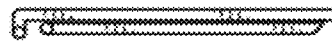
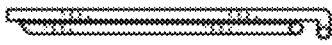
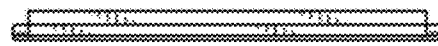
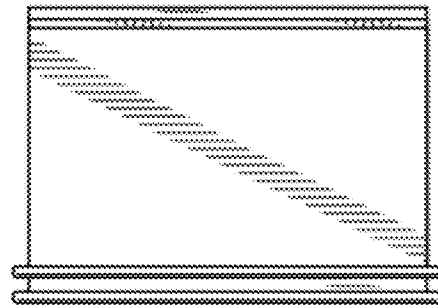
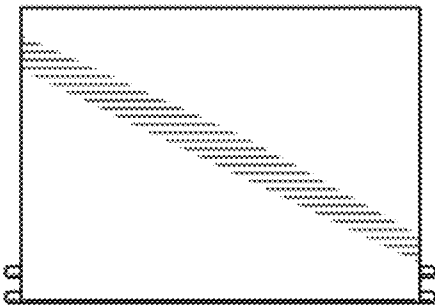
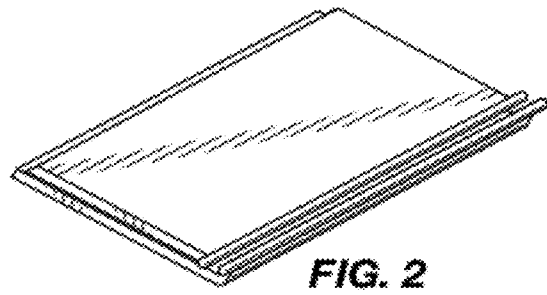
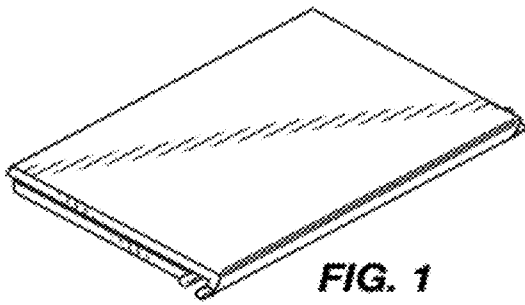

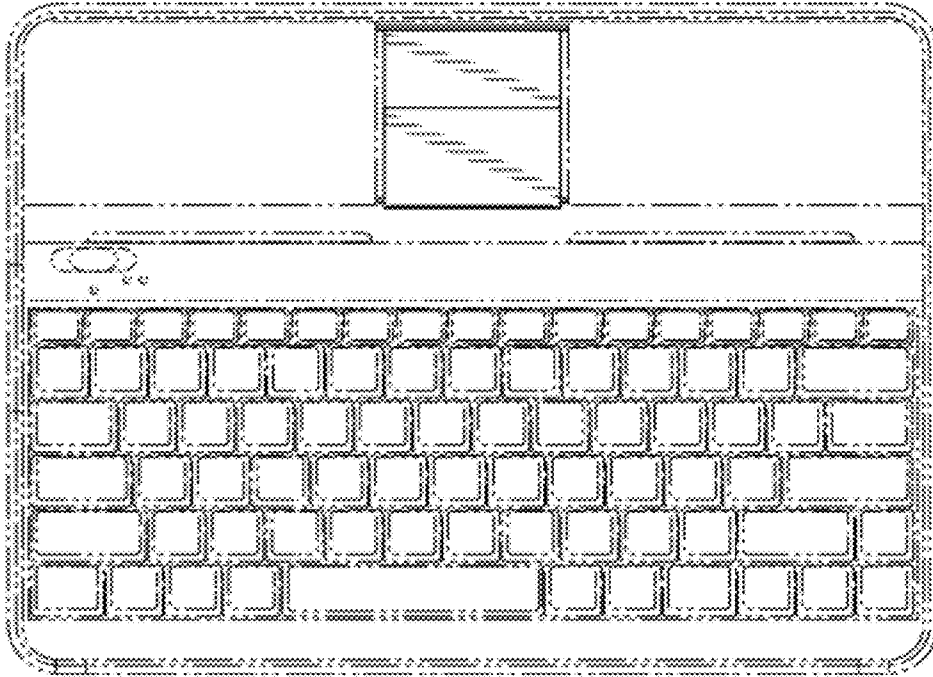

FIG. 14

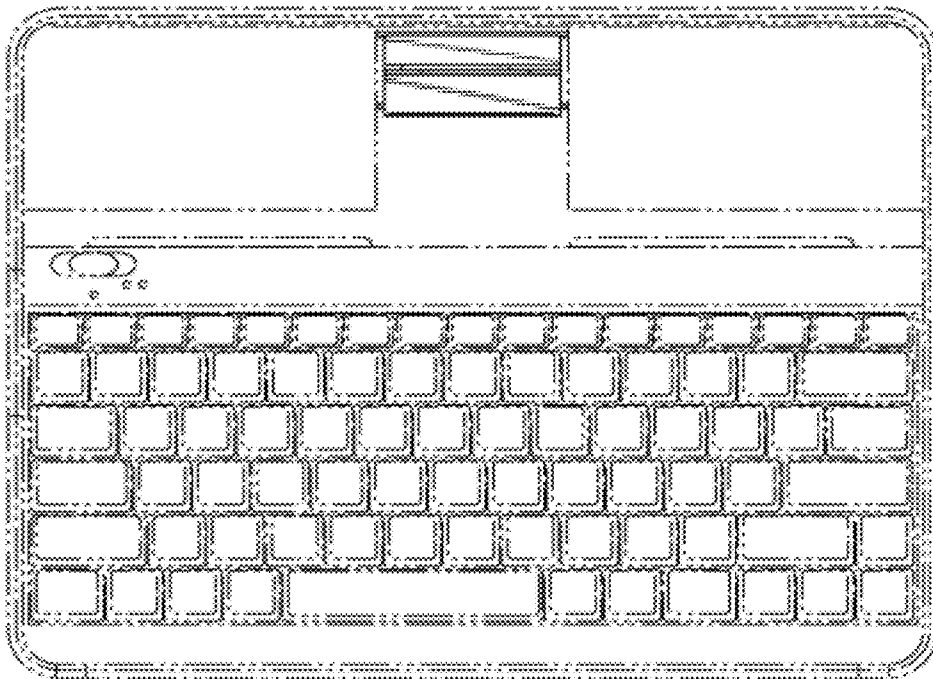

FIG. 15