



(12) **DEMANDE DE BREVET CANADIEN  
CANADIAN PATENT APPLICATION**

(13) **A1**

(86) Date de dépôt PCT/PCT Filing Date: 2020/01/13  
 (87) Date publication PCT/PCT Publication Date: 2020/11/05  
 (85) Entrée phase nationale/National Entry: 2021/10/26  
 (86) N° demande PCT/PCT Application No.: IL 2020/050048  
 (87) N° publication PCT/PCT Publication No.: 2020/222220  
 (30) Priorité/Priority: 2019/04/30 (US62/840,620)

(51) Cl.Int./Int.Cl. *A61J 1/20* (2006.01),  
*A61M 5/162* (2006.01)  
 (71) Demandeur/Applicant:  
WEST PHARMA. SERVICES IL, LTD., IL  
 (72) Inventeurs/Inventors:  
BAR-EL, YOSSI, IL;  
FABRIKANT, ELISHEVA, IL;  
BEN SHALOM, NIV, IL  
 (74) Agent: ROBIC

(54) Titre : DISPOSITIF DE TRANSFERT DE LIQUIDE AVEC POINTE IV A DOUBLE LUMIERE  
 (54) Title: LIQUID TRANSFER DEVICE WITH DUAL LUMEN IV SPIKE

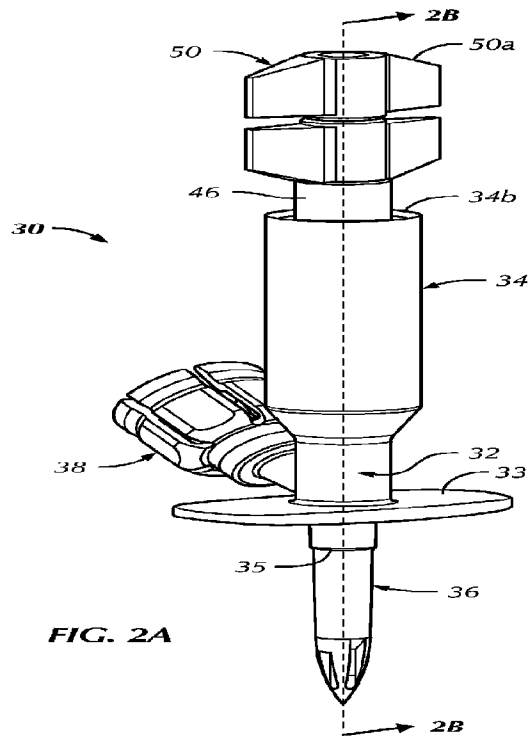

**FIG. 2A**

(57) **Abrégé/Abstract:**

A liquid transfer device includes a monolithic trifurcated connector body defining a barrel at a first end thereof, a single IV spike at a second end thereof and a vial adapter lumen at a third end thereof. An IV port is connected to the barrel. The single IV spike has a first IV spike lumen fluidly connected at a proximal end thereof with only the vial adapter lumen via the trifurcated connector body and a second IV spike lumen fluidly connected at a proximal end thereof with only the IV port via the trifurcated connector body, thereby separating fluid communication between the vial adapter and the single IV spike from fluid communication between the IV port and the single IV spike.

**Date de soumission / Date Submitted:** 2021/10/26

**No de la demande can. / CA App. No.:** 3135248

**Abrégé:**

Un dispositif de transfert de liquide comprend un corps de connecteur trifurqué définissant un cylindre à une première extrémité de celui-ci, une pointe IV unique à une seconde extrémité de celui-ci et une lumière d'adaptateur de flacon à une troisième extrémité de celui-ci. Un orifice IV est relié au corps. La pointe IV unique a une première lumière de pointe IV reliée de manière fluidique à une extrémité proximale de celle-ci avec uniquement la lumière d'adaptateur de flacon par l'intermédiaire du corps de connecteur trifurqué et une seconde lumière de pointe IV reliée de manière fluidique à une extrémité proximale de celle-ci avec uniquement l'orifice IV par l'intermédiaire du corps de connecteur trifurqué, séparant ainsi la communication fluidique entre l'adaptateur de flacon et la pointe IV unique d'une communication fluidique entre l'orifice IV et la pointe IV unique.

**Abstract:**

A liquid transfer device includes a monolithic trifurcated connector body defining a barrel at a first end thereof, a single IV spike at a second end thereof and a vial adapter lumen at a third end thereof. An IV port is connected to the barrel. The single IV spike has a first IV spike lumen fluidly connected at a proximal end thereof with only the vial adapter lumen via the trifurcated connector body and a second IV spike lumen fluidly connected at a proximal end thereof with only the IV port via the trifurcated connector body, thereby separating fluid communication between the vial adapter and the single IV spike from fluid communication between the IV port and the single IV spike.

## **LIQUID TRANSFER DEVICE WITH DUAL LUMEN IV SPIKE**

### **CROSS-REFERENCE TO RELATED APPLICATIONS**

**[0001]** This application claims priority and benefit from U.S. Provisional Patent Application No. 62/840,620, titled "Liquid Transfer Device With Dual Lumen IV Spike", filed on April 30, 2019, the entire contents of which are incorporated by reference herein.

### **BACKGROUND OF THE DISCLOSURE**

**[0002]** The present disclosure is generally directed to liquid transfer devices.

**[0003]** Conventional infusion liquid containers containing an infusion liquid to be delivered to a patient generally take the form of an infusion liquid bag, an infusion liquid bottle, and the like. A pre-filled syringe or vial is generally utilized to add a high concentration of a drug to the infusion liquid contents, via a liquid transfer device, to form a diluted, medicated infusion liquid. Thereafter, an infusion set including an IV spike may be inserted into an IV port of the liquid transfer device for infusion of medicated infusion liquid contents to a patient. Minimizing the risk of a patient receiving a portion of the drug in a highly concentrated, undiluted form is important for patient safety.

### **BRIEF SUMMARY OF THE DISCLOSURE**

**[0004]** The present disclosure realizes the advantageous manufacture of a liquid transfer device having separate lumens: one for mixing the high concentration of drug with the infusion liquid, and one for transferring the diluted, medicated infusion liquid to the infusion set, as an added measure to prevent the patient from receiving a portion of the drug in an undiluted, high concentration form. The present disclosure additionally or alternatively realizes the advantageous manufacture of a liquid transfer device capable of mixing the fluid within the lumen between the IV port and the port connected to the medicated infusion liquid contents prior to administering the medicated infusion liquid contents to a patient.

**[0005]** Briefly stated, one aspect of the present disclosure is directed to a liquid transfer device configured for use with each of an infusion liquid container containing an infusion liquid and having an intravenous (IV) port for administering the infusion liquid, a vial containing a medicament additive sealed by a vial stopper, and an infusion set including an IV spike for sealing insertion into an IV port and a connector, such as an infusion set, for administration purposes to a patient. The liquid transfer device includes a monolithic trifurcated connector

body defining a barrel at a first end thereof, a single IV spike at a second end thereof and a vial adapter lumen at a third end thereof. An IV port is connected to the barrel and configured to sealingly receive the IV spike of the infusion set. A vial adapter is permanently secured to the vial adapter lumen and configured to telescopically mount onto the vial. The vial adapter includes a vial spike fluidly connected with the vial adapter lumen and configured to puncture the vial stopper upon mounting of the vial adapter onto the vial for flow communication therewith. The single IV spike is configured to sealingly insert into the IV port of the infusion liquid container. The single IV spike has a first IV spike lumen fluidly connected at a proximal end thereof with only the vial adapter lumen via the trifurcated connector body and a second IV spike lumen fluidly connected at a proximal end thereof with only the IV port via the trifurcated connector body, thereby separating fluid communication between the vial adapter and the single IV spike from fluid communication between the IV port and the single IV spike while enabling initial introduction of the medicament additive from the vial to the infusion liquid container through the vial adapter and the first IV spike lumen for mixing with the infusion liquid to form a medicated infusion liquid, and enabling subsequent administration of the medicated infusion liquid to a patient from the infusion liquid container through the second IV spike lumen and the IV port to the infusion set. The first IV spike lumen has a first peripherally disposed distal aperture and the second IV spike lumen has a second peripherally disposed distal aperture.

**[0006]** Briefly stated, another aspect of the present disclosure is directed to a method of using a liquid transfer device having a monolithic trifurcated connector body defining a barrel at a first end thereof, a single intravenous (IV) spike at a second end thereof and a vial adapter lumen at a third end thereof. The method includes the steps of mounting a vial adapter permanently secured to the vial adapter lumen onto a vial containing a medicament additive, and, in turn, piercing a stopper of the vial with a vial spike of the vial adapter fluidly connected with the vial adapter lumen; piercing an IV port of an infusion liquid container containing an infusion liquid with the single IV spike; and adding the medicament additive within the vial to the infusion liquid within the infusion liquid container (i.e. mixing the medicament with the infusion liquid) to obtain a medicated infusion liquid via the vial adapter lumen and a first IV spike lumen of the single IV spike. The first IV spike lumen is fluidly connected at a proximal end thereof with only the vial adapter lumen via the trifurcated connector body and has a first peripherally disposed distal aperture proximate a distal end of the single IV spike. The method also includes the step of inserting an IV spike of an infusion set into an IV port of the liquid transfer device, the IV port of the liquid transfer device being fluidly connected to a second IV

spike lumen of the single IV spike. The second IV spike lumen is fluidly connected at a proximal end thereof with only the IV port and has a second peripherally disposed distal aperture proximate the distal end of the single IV spike, thereby fluidly connecting the infusion set with the infusion liquid container for administration of the medicated infusion liquid to a patient.

### **BRIEF DESCRIPTION OF THE DRAWINGS**

**[0007]** The following detailed description of aspects of the disclosure will be better understood when read in conjunction with the appended drawings. It should be understood, however, that the disclosure is not limited to the precise arrangements and instrumentalities shown. In the drawings:

**[0008]** Fig. 1A is a front elevational view of an infusion liquid container in the form of a bag usable with a liquid transfer device according to the present disclosure;

**[0009]** Fig. 1B is a front elevational view of an infusion liquid container in the form of a flexible bottle usable with a liquid transfer device according to the present disclosure;

**[0010]** Fig. 1C is a front elevational view of a pre-filled needleless syringe and a vial usable with the liquid transfer device according to the present disclosure;

**[0011]** Fig. 1D is a front elevational view of an infusion set usable with the liquid transfer device according to the present disclosure;

**[0012]** Fig. 2A is a perspective view of the liquid transfer device, in accordance with a first embodiment of the present disclosure, in a depressed plunger configuration;

**[0013]** Fig. 2B is a cross-sectional elevational view of the liquid transfer device of Fig. 2A, taken along sectional line 2B-2B of Fig. 2A;

**[0014]** Fig. 3 is a perspective view of the syringe plunger and an IV port of the liquid transfer device of Fig. 2A;

**[0015]** Fig. 4A is a perspective view of the liquid transfer device according to the present disclosure, in a withdrawn plunger configuration;

**[0016]** Fig. 4B is a cross-sectional elevational view of the liquid transfer device of Fig. 4A, taken along sectional line 4B-4B of Fig. 4A;

**[0017]** Fig. 5 is a cross-sectional elevational view of another embodiment of a liquid transfer device having an alternatively configured IV spike;

**[0018]** Fig. 6 is a cross-sectional elevational view of the liquid transfer device of Fig. 2A, taken along sectional line 2B-2B of Fig. 2A, having another alternatively configured IV spike;

[0019] Fig. 7A is an enlarged cross-sectional elevational view of one configuration of a vial adapter of the liquid transfer device of Fig. 2A;

[0020] Fig. 7B is an enlarged cross-sectional elevational view of another configuration of a vial adapter of the liquid transfer device of Fig. 2A;

[0021] Fig. 8 is a perspective view of a liquid transfer device, in accordance with a second embodiment of the present disclosure;

[0022] Fig. 9 is a cross-sectional elevational view of the liquid transfer device of Fig. 8, taken along sectional line 9-9 of Fig. 8; and

[0023] Fig. 10 is an enlarged partial, exploded, perspective view of an alternative attachment between a trifurcated connector body and an elongate connecting member, such as an IV port, of the liquid transfer device of Fig. 8.

[0024] Figs. 11A and 11B are cross-sectional elevational views of another embodiment of the liquid transfer device of Fig. 6 having an internal valve.

#### **DETAILED DESCRIPTION OF THE DISCLOSURE**

[0025] Certain terminology is used in the following description for convenience only and is not limiting. The words “lower,” “bottom,” “upper” and “top” designate directions in the drawings to which reference is made. The words “inwardly,” “outwardly,” “upwardly” and “downwardly” refer to directions toward and away from, respectively, the geometric center of the liquid transfer device, and designated parts thereof, in accordance with the present disclosure. Unless specifically set forth herein, the terms “a,” “an” and “the” are not limited to one element, but instead should be read as meaning “at least one.” The terminology includes the words noted above, derivatives thereof and words of similar import.

[0026] It should also be understood that the terms “about,” “approximately,” “generally,” “substantially” and like terms, used herein when referring to a dimension or characteristic of a component of the disclosure, indicate that the described dimension/characteristic is not a strict boundary or parameter and does not exclude minor variations therefrom that are functionally similar. At a minimum, such references that include a numerical parameter would include variations that, using mathematical and industrial principles accepted in the art (e.g., rounding, measurement or other systematic errors, manufacturing tolerances, etc.), would not vary the least significant digit.

[0027] Referring to the drawings in detail, wherein like numerals indicate like elements throughout, there is shown in Figs. 2A-6 a liquid transfer device 30, in accordance with a first embodiment of the present disclosure, intended for use with the combination of infusion liquid

containers containing an infusion liquid and additive transfer devices. In the illustrated embodiment, the liquid transfer device 30 is intended for use with an infusion liquid container in the form of an infusion liquid bag 10 (Fig. 1A). As should be understood by those of ordinary skill in the art, a conventional infusion liquid bag 10 includes a reservoir 12 containing infusion liquid, in fluid communication with an intravenous administration port 14 and an additive port 16. The infusion liquid bag 10 is collapsible upon administration of the infusion liquid therefrom. The liquid transfer device 30 may also be used with an infusion liquid container in the form of a flexible infusion liquid bottle 18 (Fig. 1B) or the like. The liquid transfer device 30 of the illustrated embodiment is also intended for use with an additive transfer device in the form of a sealed vial 20 (Fig. 1C). The vial 20 generally contains a highly concentrated medicament liquid additive or a lyophilized powder drug requiring reconstitution prior to administration to a patient, i.e., requiring mixing with the infusion liquid in the bag 10 to form a medicated infusion liquid administered to a patient. The contents of the vial 20 are, therefore, introduced into the infusion liquid bag 10 via the liquid transfer device 30 (as will be described in further detail below). The liquid transfer device 30 may also, however, take a different configuration intended for use with a syringe 22 (Fig. 1C) containing a medicament liquid additive.

**[0028]** The liquid transfer device 30 includes a trifurcated connector body 32. In the illustrated embodiment of Figs. 2A-6, the trifurcated connector body 32 is a monolithic body defining a barrel 34 at a first end thereof, a single IV spike 36 at a second end thereof, and a vial adapter 38 at a third end thereof, but the disclosure is not so limited (as described further below). As shown best in Figs. 2B, 4B and 5, the barrel 34 defines an internal chamber 34a having an open proximal end 34b for slidably receiving a plunger 40 (as will be described further below). The IV spike 36 defining the second end of the trifurcated body 32 enables use of the liquid transfer device 30 with infusion liquid bags 10, i.e., for sealingly inserting the IV spike 36 into the administration port 14 of the bag 10. The IV spike 36 may be constructed from a suitable rigid metal, polymeric or plastic material, such as, for example, polycarbonate and the like. A flange 33 extends laterally from the IV spike 36 proximate a proximal end thereof to provide a gripping or bearing surface to enable a user to more easily insert the IV spike 36 into a liquid container, such as bag 10. The IV spike may optionally include a feature, such as raised step 35 around the circumferential surface of the IV spike 36, for restricting insertion depth into the administration port 14 of the bag 10. In one embodiment, the flange 33 may also be formed as an injection molded monolithic structure with the connector body

32, but the disclosure is not so limited. A spike cap (not shown) may removably cover the IV spike 36 when not in use.

**[0029]** As shown, the IV spike 36 is co-directional and/or coaxial with the barrel 34 and includes two internal lumens 36a, 36b. In the illustrated configurations, the lumens 36a, 36b extend generally parallel to one another. The first IV spike lumen 36a is continuously and directly fluidly connected at a proximal end with only a vial adapter lumen 37 located within the vial adapter 38 angularly bifurcating from, i.e., branching off of, the IV spike 36. The first IV spike lumen 36a includes a first peripherally disposed distal aperture 36c. As shown best in Figs. 2B, 4B and 5, the first IV spike lumen 36a is not fluidly connected at the proximal end thereof with the barrel chamber 34a. The second IV spike lumen 36b is directly fluidly connectable at a proximal end with only the barrel chamber 34a and includes a second peripherally disposed distal aperture 36d, separate from the first distal aperture 36c of the first IV spike lumen 36a. The second IV spike lumen 36b is not fluidly connected at the proximal end thereof with the vial adapter lumen 37 or at any point along the length of the IV spike 36. In other words, IV spike 36 includes two separate lumens 36a, 36b that extend through the IV spike 36 to provide discrete fluid paths that are not connected within the IV spike 36. Thus, fluid communication between the vial adapter 38 and the IV spike 36 is separate from fluid communication between the barrel chamber 34a and the IV spike 36.

**[0030]** The vial adapter 38 is configured to mount onto a vial 20 to enable usage of the device 30 with an additive transfer device in the form of a vial 20. In one configuration, the vial adapter 38 may be integrally formed at the third end of the connector body 32, i.e., monolithically formed with the terminal end of the vial adapter lumen 37 or otherwise permanently secured and sealed to the terminal end of the vial adapter lumen 37, but the disclosure is not so limited. As used herein through the specification and the claims, “permanently secured” means not disconnectable/removable without causing damage to the device or portion thereof. As one non-limiting example, the vial adapter 38 may be ultrasonically welded to the vial adapter lumen 37.

**[0031]** Referring to Fig. 7A, the vial adapter 38 includes a top wall 38d, a flexible and/or flared skirt 38a depending therefrom for telescopic snap fit mounting onto a vial 20 (in a standard manner) and a vial spike 38b for puncturing the vial 20, e.g., through a stopper thereof, to fluidly communicate with the interior of the vial 20. The puncturing vial spike 38b includes a lumen 38c in fluid communication with the vial adapter lumen 37, and, in turn with the first IV spike lumen 36a. As should be understood by those of ordinary skill in the art, the inner

diameter of the vial spike 38b, i.e., the diameter of the lumen 38c, and/or the outer diameter of the vial spike 38b may be dimensioned as appropriate for the intended use.

**[0032]** In the configuration of Fig. 7A, the vial spike 38b includes a base section 39 that is generally concave with respect to the axis of the vial spike 38b. The vial adapter 38 may alternatively be configured to minimize/protect against leakage resulting from the tear that forms in the stopper of a vial 20 as the vial adapter 38 is pushed down onto the vial 20 and the vial spike 38b advances through the stopper. As illustrated in the configuration of Fig. 7B, the direction of extension of the base section 39' is generally convex with respect to the axis of the vial spike 38b such that the base section 39' has a generally bulbous configuration. When the vial adapter 38 is pushed down onto the vial 20 and the spike 38b advances through the vial stopper, the base section 39' is compressed against an upper surface of the vial stopper and the compressed material of the vial stopper surrounds tears formed in the vial stopper for sealing thereof. Puncturing of the vial stopper by the vial spike 38b is generally accompanied by the formation of a depression in the upper surface of the vial stopper. The convex base section 39' is configured to fill in the depression, thereby minimizing/protecting against leakage. As should be understood by those of ordinary skill in the art, however, different sealing base sections/means, currently known, or that later become known, may be employed to minimize leakage between the vial spike 38b and the elastic stopper of vial 20. As also should be understood, other vial adapter configurations, currently known, or that later become known, may alternatively be employed.

**[0033]** Turning to the plunger 40, as shown best in Figs. 2B, 3, 4B and 5, the plunger 40 includes an upright plunger tube 46, defining a plunger tube lumen 46a therein. The plunger tube 46 is slidably engaged with the barrel 34 via a peripheral sealing member 42 (constructed, for example, of an elastomeric material or the like) interposed therebetween in a manner well understood by those of ordinary skill in the art, permitting sliding within the barrel 34 while creating a substantially air-tight seal between the plunger tube 46 and the interior sidewall of the barrel 34. The plunger tube 46 and the sealing member 42, in combination with the barrel 34, define a sealed proximal end of the barrel chamber 34a. The plunger tube 46 includes a distal, elongate neck portion 44 terminating in a check valve 48. In the illustrated embodiment, the check valve 48 takes the form of a duckbill valve, constructed of an elastomeric material or the like, but the disclosure is not so limited. For example, without limitation, the check valve 48 may take the form of several other types of one-way valves, such as, for example, a ball valve, a silicone flapper valve, a diaphragm-type valve, an in-line valve, a stop-check

valve, a lift-check valve, or the like, capable of performing the functions of the check valve 48 described herein.

**[0034]** As shown, an IV port 50 is fluidly connected with a proximal end of the plunger tube 46. The IV port 50 includes a twist-off member 50a proximate a peripheral, free proximal end of the port 50, and an elongate connecting member 52 projecting distally therefrom, having an internal lumen 52a extending therethrough and terminating in an open end (opposite end from the twist-off member 50a). The internal lumen 52a of the IV port 50 extends co-directionally and/or coaxially with the plunger lumen 46a. In one embodiment, the IV port 50 may be constructed from a suitable flexible polymeric or plastic material, such as, for example, PVC, and the like. In the illustrated embodiment, the elongate connecting member 52 is adhered, i.e., adhesively bonded, with the plunger tube 46, but the disclosure is not so limited. For example, without limitation, the elongate connecting member 52 may be permanently secured and rotationally fixedly attached to the plunger tube 46 (for example, as described in further detail below with respect to Figs. 8 to 10).

**[0035]** The IV port 50 includes a septum 50b positioned within the elongate connecting member 52, sealing across the internal lumen 52a. Accordingly, the twist-off member 50a may be removed without leading to flow communication beyond the septum 50b. Flow communication beyond the septum 50b, i.e., with the plunger lumen 46a and beyond, is only achieved upon puncturing the septum 50b (as described in further detail below). The twist off member 50a keeps the IV port 50, and particularly the septum 50b, sterile until use.

**[0036]** In use, the liquid transfer device 30 may be coupled to an infusion liquid bag 10 via the IV spike 36 (as previously described). Thereafter, the user withdraws the plunger 40 in a proximal direction, i.e. in a direction away from the IV spike 36(Figs. 4A, 4B). Alternatively, a dedicated handle may be employed and attached to the plunger 40 for translation thereof. Withdrawal of the plunger 40, with the distal aperture 36d immersed in the infusion liquid within the bag 10, pulls fluid from the bag 10, through the distal aperture 36d, through the second IV spike lumen 36b and into the barrel chamber 34a. The duckbill valve 48 is configured to prevent fluid flow into the plunger tube lumen 46a during plunger 40 withdrawal. As should be understood by those of ordinary skill in the art, withdrawal of the plunger 40 creates a vacuum in the barrel chamber 34a, resulting in a pressure difference relative to the infusion liquid bag 10, thereby pulling the fluid into the barrel chamber 34a. As also should be understood, the infusion liquid remains within the barrel chamber 34a and the second IV spike lumen 36b until manually ejected, in a manner well understood by those of ordinary skill in the art, as will be described below.

**[0037]** Prior or subsequent to withdrawing infusion liquid from the infusion liquid bag 10 into the barrel chamber 34a, the liquid transfer device 30 may be coupled to a vial 20 via the vial adapter 38 (as previously described). A user may mix/combine the contents within the vial 20 with the contents within the infusion liquid bag 10 via the vial adapter lumen 37 and the first IV spike lumen 36a by inverting the infusion liquid bag 10 and device 30, i.e. positioning the vial 20 above the bag 10, so that the contents of the vial 20 drain into the infusion liquid bag 10. Where the vial 20 contains a lyophilized powder drug, the drug can be reconstituted in a similar fashion. After coupling the vial 20 to the liquid transfer device 30, the liquid bag 10 is held above the vial 20, so that liquid from the liquid bag 10 drains into the vial 20 and reconstitutes the contents of the vial 20. The infusion liquid bag 10 and device 30 may then be inverted, as previously described, to drain the reconstituted contents of the vial 20 into the bag 10.

**[0038]** After mixing/combining the contents within the infusion liquid bag 10 and the vial 20 and orienting the liquid transfer device 30 such that the combined liquid flows into the infusion liquid bag 10, the plunger 40 is depressed until at least portion of the duckbill valve 48 engages the proximal end/rim of the second IV spike lumen 36b. In the illustrated embodiment, at least one of the elastomeric lips/flaps of the duckbill valve 48 abuts, and is displaced/compressed by, the proximal end 41 of the second IV spike lumen 36b, thereby opening the duckbill valve 48 for fluid-flow therethrough. That is, sustained pressure applied onto at least one of the elastomeric lips/flaps of the duckbill valve 48, resulting from the depression of the plunger 40 to a position engaging the valve 48 with the proximal end/rim 41 of the second IV spike lumen 36b, displaces the elastomeric lips/flaps of the valve 48 from one another, thereby breaking the seal therebetween and permitting fluid flow therethrough. Thereafter, the twist-off member 50a is removed (in a manner well understood) to provide access to the internal lumen 52a. An IV port spike 96 of an infusion set 95 (Fig. 1D) is sealingly inserted into the internal lumen 52a and fully penetrates the septum 50b, thereby fluidly connecting the IV port spike 96 with any remainder of the internal lumen 52a beyond the septum 50b, and, in turn, with the plunger lumen 46a and the second IV spike lumen 36b (via the open duckbill valve 48) for administration of the medicated infusion liquid to a patient. The IV port spike 96 typically extends from an end of a drip chamber 97a of the infusion set 95. Conventionally, an infusion set 95 additionally includes a roller clamp 97c for controlling fluid administration to a patient, a male Luer connector 97d, and tubing 97b to fluidly connect the roller clamp 97c to the drip chamber 97a.

**[0039]** Advantageously, the medicated infusion liquid is fluidly connected to the infusion set 95 via the second IV spike lumen 36b rather than the first IV spike lumen 36a, which is utilized only to admix the highly concentrated drug additive within the vial 20 with the infusion liquid within the bag 10. Thus, the possibility of administering a portion of the drug additive in an undiluted, high concentration form to a patient is minimized. Moreover, as the plunger 40 is depressed (as previously described), infusion liquid within the barrel chamber 34a is ejected through the second IV spike lumen 36b and out the distal aperture 36d. Therefore, after utilizing the liquid transfer device 30 to admix the contents within the infusion liquid bag 10 and the vial 20, the second IV spike lumen 36b and the distal aperture 36d thereof, though not utilized for mixing, are nevertheless flushed out prior to use thereof for transferring the medicated infusion liquid from the bag 10 to the infusion set 95, to further minimize the possibility of administering a portion of the drug additive in an undiluted, high concentration form to a patient.

**[0040]** In an alternative configuration, as shown in Fig. 5, a distal end of the IV spike 36' is configured such that the first IV spike lumen 36a' extends further distally than the second IV spike lumen 36b'. Advantageously, therefore, the first distal aperture 36c' is separated by a distance "d" from the distal aperture 36d', thereby further minimizing the opportunity for a portion of the drug in an undiluted, high concentration form from exiting the first distal aperture 36c' and entering the distal aperture 36d'. The distance "d" is preferably greater than or equal to about 1.0 mm, more preferably greater than or equal to about 2.5 mm, and most preferably greater than or equal to about 4.0 mm.

**[0041]** In another alternative configuration, as shown in Fig. 6, the IV spike 36'' may include a single lumen 36a'' with a single distal aperture 36c''. This configuration operates in a similar manner as with the configuration shown in Figs. 2-4B, except that withdrawing/ejecting fluid from or into the barrel chamber 34a and mixing the drug with fluid occurs in part through a common portion of the single lumen 36a''. Flushing of the lumen 36a'', as previously described, is performed between the steps of mixing/combining the contents within the infusion liquid bag 10 and the vial 20, and removing the twist-off member 50a for connection of the infusion set 95.

**[0042]** In a preferred embodiment illustrated in Figures 11A and 11B, a flow control valve 43 may be incorporated in the device, such that rotation of the flow control valve 43 allows a user to selectively fluidly connect either the vial adapter lumen 37 or the barrel chamber 34a with the single lumen 36a''. The valve 43 may prevent any highly concentrated drug additive within the vial 20 from being drawn into the barrel chamber 34a when the plunger tube 46 is

withdrawn, as illustrated in Fig. 11A. Prior to mixing the contents of the vial 20 into the bag 10, the valve 43 may be rotated in order to provide a fluid connection between the vial adapter lumen 37 and the single lumen 36a", as well as seal off the barrel chamber 34a, as illustrated in Fig. 11B. In order to flush the volume of liquid within the single lumen 36a", the valve 43 may be rotated back to its original position in Fig. 11A prior to depressing the plunger tube 46.

**[0043]** In another alternative embodiment, the vial adapter 38 may be detachable. For example, the device may be provided with a valve, such as the needleless additive control valve disclosed in U.S. Patent No. 8,551,067, the contents of which are incorporated by reference herein. The valve would allow the vial adapter 38 to be detached prior to withdrawing the plunger tube 46. The vial adapter 38 and vial 20 would then be connected via the valve to empty the highly concentrated contents of the vial 20 into the bag 20 followed by depression of the plunger tube 46 to flush the single lumen 36a".

**[0044]** Figs. 8-10 illustrate a second embodiment of the liquid transfer device 130. The reference numerals of the second embodiment are distinguishable from those of the above-described first embodiment configurations (Figs. 2A-7B) by a factor of one-hundred (100), but otherwise indicate the same elements as indicated above, except as otherwise specified. The liquid transfer device 130 of the present embodiment is similar to that of the first embodiment configurations. Therefore, the description of certain similarities and modes of operation between the embodiments may be omitted herein for the sake of brevity and convenience, and, therefore, is not limiting.

**[0045]** One difference of the liquid transfer device 130 over the liquid transfer device 30 pertains to the configuration of the first end of connector body 132. As shown in Figs. 8 and 9, the plunger 40 is removed and the IV port 150 is directly and permanently secured and sealed to the barrel 134, i.e., not disconnectable/removable without causing damage to at least one of the IV port 150 or the barrel 134 or otherwise to the device 130. Accordingly, the second IV spike lumen 136b of the single IV spike 136 is in direct and continuous fluid communication at a proximal end with only the internal lumen 152a of the elongate connecting member 152 of the IV port 150, while remaining not fluidly connected at the proximal end thereof with the vial adapter lumen 137. The first IV spike lumen 136a of the single IV spike 136 also remains continuously and directly fluidly connected at a proximal end with only the vial adapter lumen 137 and not fluidly connected at the proximal end thereof with the internal lumen 152a of the elongate connecting member 152.

**[0046]** In the illustrated embodiment of Figs. 8 and 9, the elongate connecting member 152 is adhered, i.e., adhesively bonded, with the barrel 134. As previously noted, the elongate

connecting member 152 may be permanently secured attached to the barrel 134. For example, as shown in Fig. 10, the barrel 134 may terminate in a barbed fitting member 154 having an open end 154a. The barbed fitting member 154 may be configured, i.e., size, dimension, material, relative to the internal diameter and material of the elongate connecting member 152 to advance into the internal lumen 152a and form a barbed, friction, i.e., interference, fit therebetween. As should be understood by those of ordinary skill in the art, the orientation of the barbed fitting member 154 permits advancement thereof into the internal lumen 152a to sealingly and securely mount the IV port 150 co-directionally upon the barrel 134 of the connector body 132, and also substantially prevent withdrawal of the barbed fitting member 154 without damaging at least one of the elongate connecting member 152 and the barbed fitting member 154.

**[0047]** As shown, the barbed fitting member 154 is frustoconically shaped, having a progressively increasing diameter in a direction away from the open end 154a. An opposing end of the barbed fitting member 154 defines a greater diameter from the underlying portion of the barrel 134, resulting in an annular rib 156 that provides an interference fit with the interior sidewall of the elongate connecting member 152, upon attempted withdrawal of the barbed fitting member 154 out of the elongate connecting member 152. Accordingly, the barbed fitting member 154 is advanceable into the internal lumen 152a of the elongate connecting member 152 during assembly, and, thereafter, is not readily able to be withdrawn without causing damage.

**[0048]** Additionally, the rim of the elongate connecting member 152 defining an open end 152b thereof includes at least one cutout 158a, and the barrel 134 includes a corresponding at least one radial tab 158b protruding from the barrel 134 and configured to mate with the at least one cutout 158a. In the illustrated embodiment, the elongate connecting member 152 includes a plurality of angularly spaced cutouts 158a, and the barrel 134 includes a corresponding plurality of angularly spaced tabs 158b. The tab(s) 158b mates with the cutout(s) 158a during mounting of the IV port 150 upon the barbed fitting member 154 of the barrel 134, to rotationally fix the IV port 150 relative to the remainder of the liquid transfer device 130. The tab(s) 158b also prevent relative rotation between the barrel 134 and the elongate connecting member 152 and enable a twist-off member 150a to be removed, as noted below, prior to connection to the infusion set 95.

**[0049]** In use, the liquid transfer device 130 may be coupled to a vial 20 via the vial adapter 138 and the user may mix/combine the contents within the vial 20 with the contents within the infusion liquid bag 10, via the vial adapter lumen 137 and the first IV spike lumen 136a. After

mixing/combining the contents within the infusion liquid bag 10 and the vial 20 and orienting the liquid transfer device 130 such that the combined liquid flows into the infusion liquid bag 10, the twist-off member 150a is removed (in a manner well understood) to provide access to the internal lumen 152a and the IV port spike 96 of an infusion set 95 (Fig. 1D) is sealingly inserted into the internal lumen 152a and fully penetrates the septum 150b, thereby fluidly connecting the IV port spike 96 with any remainder of the internal lumen 152a beyond the septum 150b, and, in turn, with the second IV spike lumen 136b for administration of the medicated infusion liquid to a patient.

**[0050]** It will be appreciated by those skilled in the art that changes could be made to the embodiments described above without departing from the broad inventive concepts thereof. For example instead of a vial adapter, the trifurcated connector body 32, 134 may include a normally closed (NC) needleless additive port (not shown) at the third end thereof (enabling selection of use with a syringe 22 or with a vial 20). As another example, the vial adapter 38, 138 can be replaced by a manually operated stop cock, and the like. As yet another example, the liquid transfer device 30 may include a locking mechanism to stabilize and/or lock the plunger 40 in the different positions thereof. It is understood, therefore, that this invention is not limited to the particular embodiments disclosed, but it is intended to cover modifications within the spirit and scope of the present disclosure, as set forth in the appended claims.

## CLAIMS

We claim:

1. A liquid transfer device configured for use with each of an infusion liquid container containing an infusion liquid and having an intravenous administration port for administering the infusion liquid, a vial containing a medicament additive sealed by a vial stopper, and an infusion set including an IV port spike and a connector for administration purposes to a patient, the liquid transfer device comprising:

a monolithic trifurcated connector body defining a barrel at a first end thereof, a single IV spike at a second end thereof and a vial adapter lumen at a third end thereof;

an IV port connected to the barrel and configured to sealingly receive the IV port spike of the infusion set;

a vial adapter comprising the vial adapter lumen and configured to telescopically mount onto the vial, the vial adapter including a vial spike fluidly connected with the vial adapter lumen and configured to puncture the vial stopper upon mounting of the vial adapter onto the vial for flow communication therewith, and

the single IV spike being configured to sealingly insert into the intravenous administration port of the infusion liquid container, and the single IV spike having:

a first IV spike lumen fluidly connected at a proximal end thereof with only the vial adapter lumen via the trifurcated connector body, the first IV spike lumen having a first peripherally disposed distal aperture; and

a second IV spike lumen fluidly connected at a proximal end thereof with only the IV port via the trifurcated connector body, the second IV spike lumen having a second peripherally disposed distal aperture;

thereby separating fluid communication between the vial adapter and the single IV spike from fluid communication between the IV port and the single IV spike while enabling initial introduction of the medicament additive from the vial to the infusion liquid container through the vial adapter and the first IV spike lumen for mixing with the infusion liquid to form a medicated infusion liquid, and enabling subsequent administration of the medicated infusion liquid to a patient from the infusion liquid container through the second IV spike lumen and the IV port to the infusion set.

2. The liquid transfer device of claim 1,  
wherein the first IV spike lumen is directly and continuously fluidly connected with only the vial adapter lumen.
3. The liquid transfer device of claim 2,  
wherein the second IV spike lumen is directly and continuously fluidly connected with only the IV port.
4. The liquid transfer device of any one of the preceding claims,  
wherein the IV port is permanently secured to the barrel.
5. The liquid transfer device of any one of the preceding claims,  
wherein the first IV spike lumen extends further distally than the second IV spike lumen, whereby the first peripherally disposed distal aperture is distally spaced from the second peripherally disposed distal aperture along the single IV spike.
6. The liquid transfer device of any one of the preceding claims,  
further comprising a plunger including a plunger tube defining a plunger tube lumen therein,  
wherein the barrel defines an internal chamber fluidly connected with the second IV spike lumen and sealingly and slidably receiving the plunger tube.
7. The liquid transfer device of claim 6,  
wherein the plunger tube is fluidly connected with the IV port via a proximal end thereof and the plunger tube includes a check valve at a distal end thereof, whereby the IV port is fluidly connected with the second IV spike lumen in an open position of the check valve and fluidly disconnected from the second IV spike lumen in a closed position of the check valve.
8. The liquid transfer device of any one of the preceding claims,  
wherein the first IV spike lumen and the second IV spike lumen extend parallel to one another.

9. A method of using a liquid transfer device having a monolithic trifurcated connector body defining a barrel at a first end thereof, a single intravenous (IV) spike at a second end thereof and a vial adapter lumen at a third end thereof,

the method comprising:

mounting a vial adapter comprising the vial adapter lumen onto a vial containing a medicament additive, and, in turn, piercing a stopper of the vial with a vial spike of the vial adapter fluidly connected with the vial adapter lumen;

piercing an administration port of an infusion liquid container containing an infusion liquid with the single IV spike;

adding the medicament additive within the vial to the infusion liquid within the infusion liquid container to obtain a medicated infusion liquid via the vial adapter lumen and a first IV spike lumen of the single IV spike, the first IV spike lumen being fluidly connected at a proximal end thereof with only the vial adapter lumen via the trifurcated connector body and having a first peripherally disposed distal aperture proximate a distal end of the single IV spike;

inserting an IV port spike of an infusion set into an IV port of the liquid transfer device, the IV port of the liquid transfer device being fluidly connected to a second IV spike lumen of the single IV spike, wherein the second IV spike lumen is fluidly connected at a proximal end thereof with only the IV port and having a second peripherally disposed distal aperture proximate the distal end of the single IV spike, thereby fluidly connecting the infusion set with the infusion liquid container for administration of the medicated infusion liquid to a patient.

10. The method of claim 9,

wherein the first IV spike lumen extends further distally than the second IV spike lumen, whereby the first peripherally disposed distal aperture is distally spaced from the second peripherally disposed distal aperture along the single IV spike.

11. A liquid transfer device configured for use with each of an infusion liquid container containing an infusion liquid and having an intravenous administration port for administering the infusion liquid, a vial containing a medicament additive sealed by a vial stopper, and an infusion set including an IV port spike and a connector for administration purposes to a patient,

the liquid transfer device comprising:

a monolithic trifurcated connector body defining a barrel at a first end thereof, a single IV spike at a second end thereof and a vial adapter lumen at a third end thereof;

an IV port connected to the barrel and configured to sealingly receive the IV port spike of the infusion set;

a vial adapter comprising the vial adapter lumen and configured to telescopically mount onto the vial, the vial adapter including a vial spike fluidly connected with the vial adapter lumen and configured to puncture the vial stopper upon mounting of the vial adapter onto the vial for flow communication therewith,

the single IV spike comprising an IV spike lumen and being configured to sealingly insert into the intravenous administration port of the infusion liquid container, and

a plunger including a plunger tube defining a plunger tube lumen therein, wherein the barrel defines an internal chamber fluidly connected with the IV spike lumen and sealingly and slidably receiving the plunger tube,

wherein plunger tube is fluidly connected with the IV port via a proximal end thereof and the plunger tube includes a check valve at a distal end thereof, whereby the IV port is fluidly connected with the second IV spike lumen in an open position of the check valve and fluidly disconnected from the second IV spike lumen in a closed position of the check valve.

12. The liquid transfer device of claim 11,  
further comprising a flow control valve configured to selectively fluidly connect the IV spike lumen to the vial adapter lumen or the barrel.
13. The liquid transfer device of claim 11,  
wherein the vial adapter is detachable.

1/14

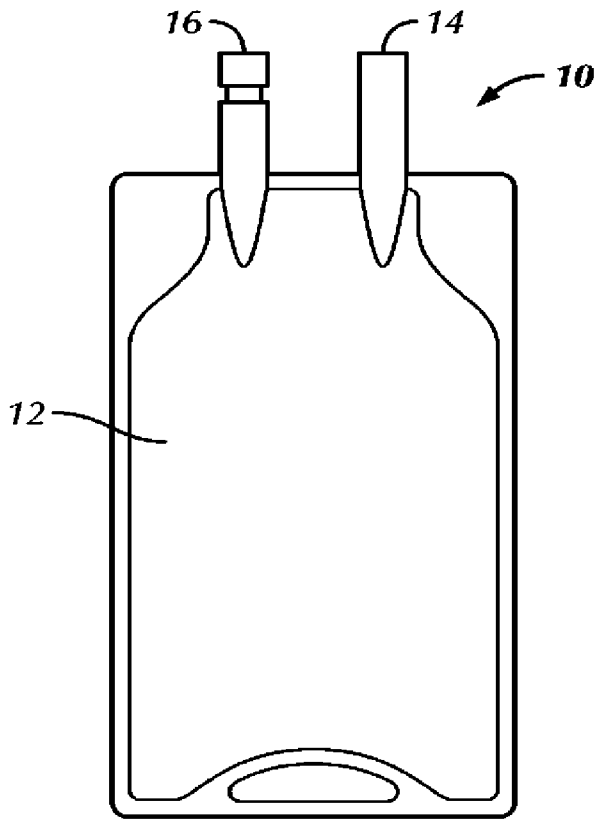

FIG. 1A

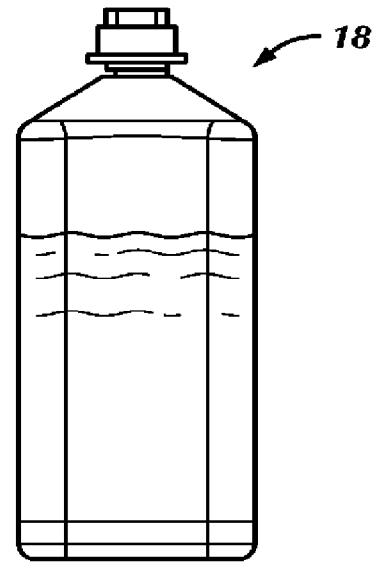

FIG. 1B

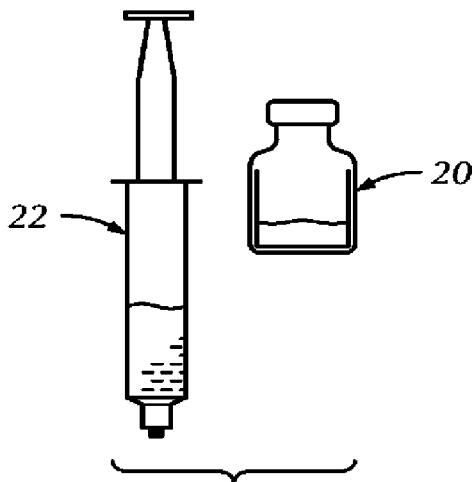

FIG. 1C

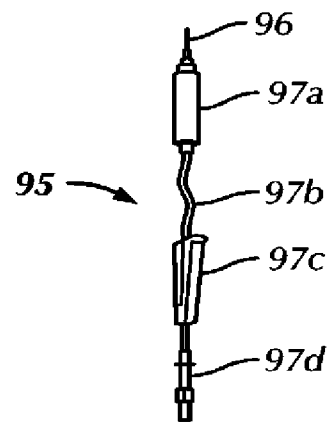
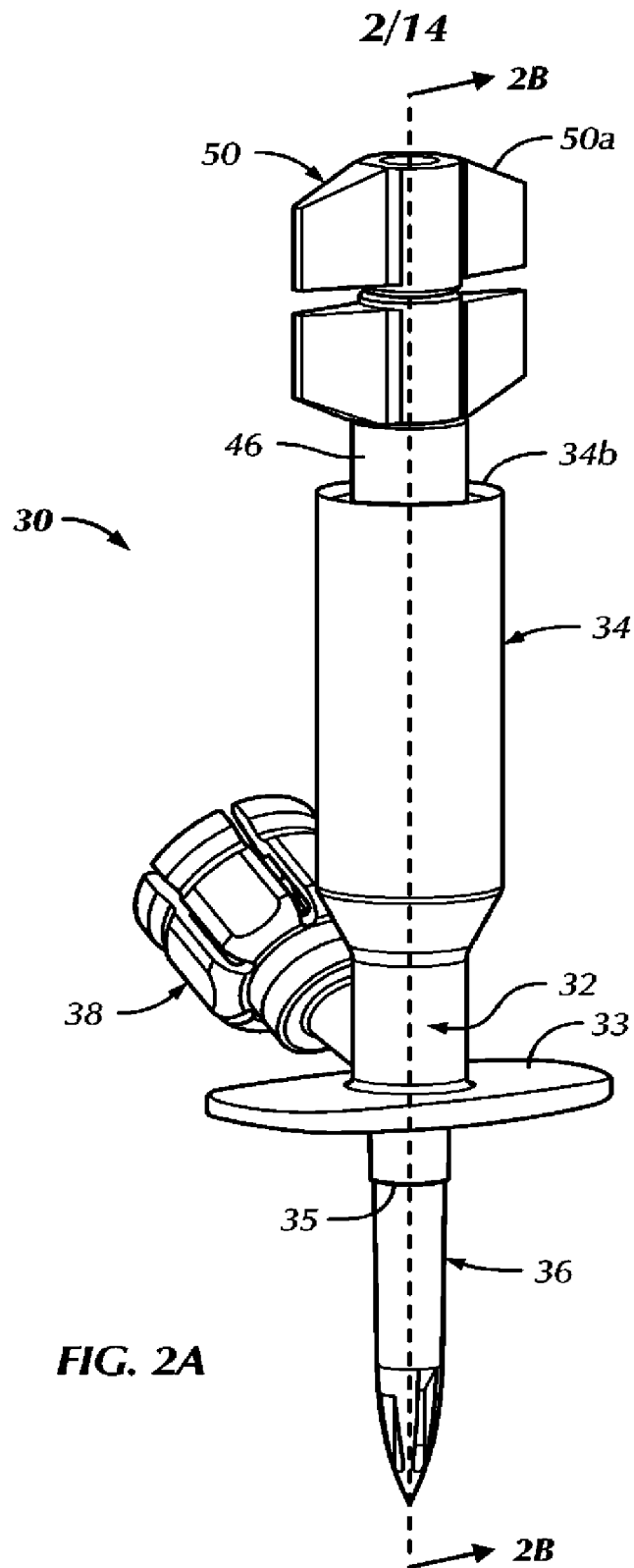

FIG. 1D





4/14

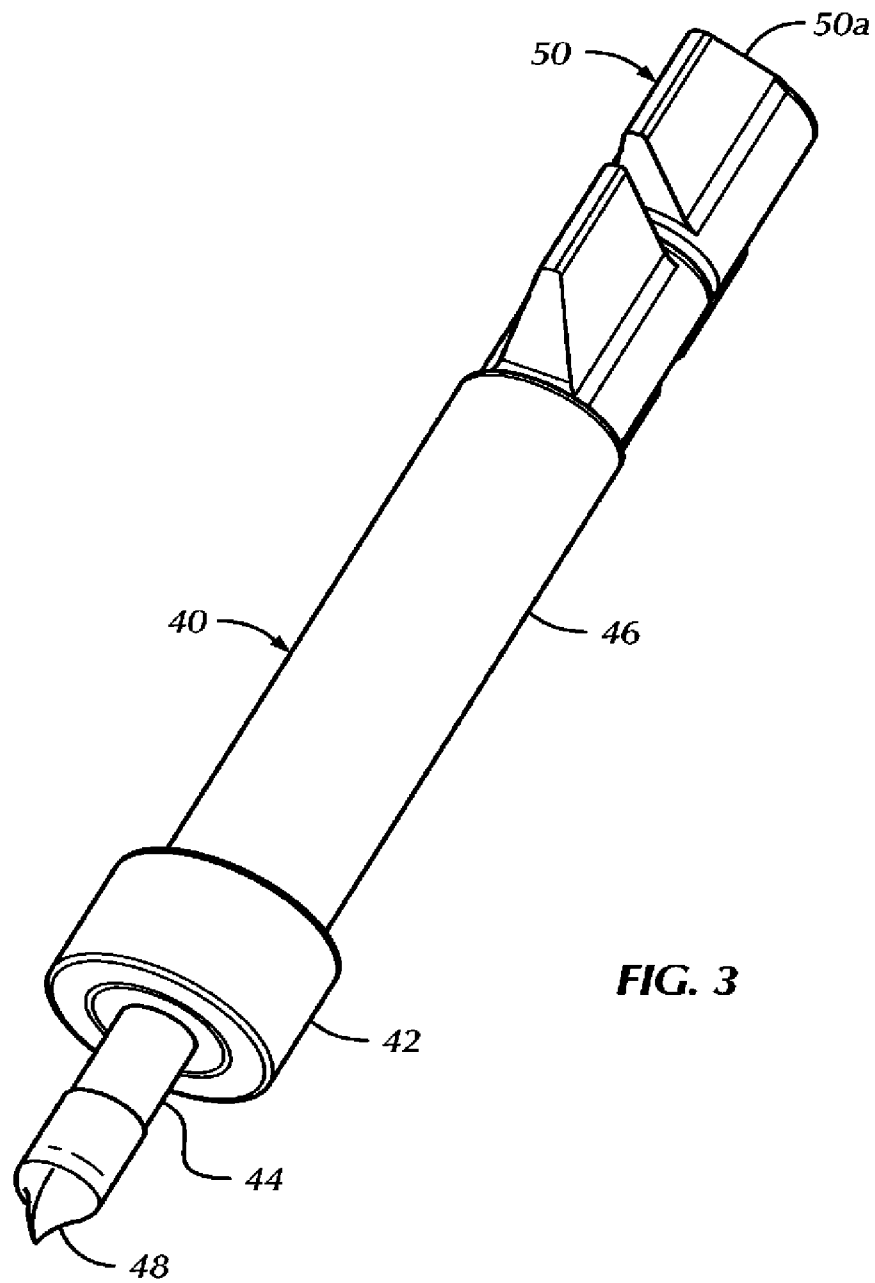

FIG. 3

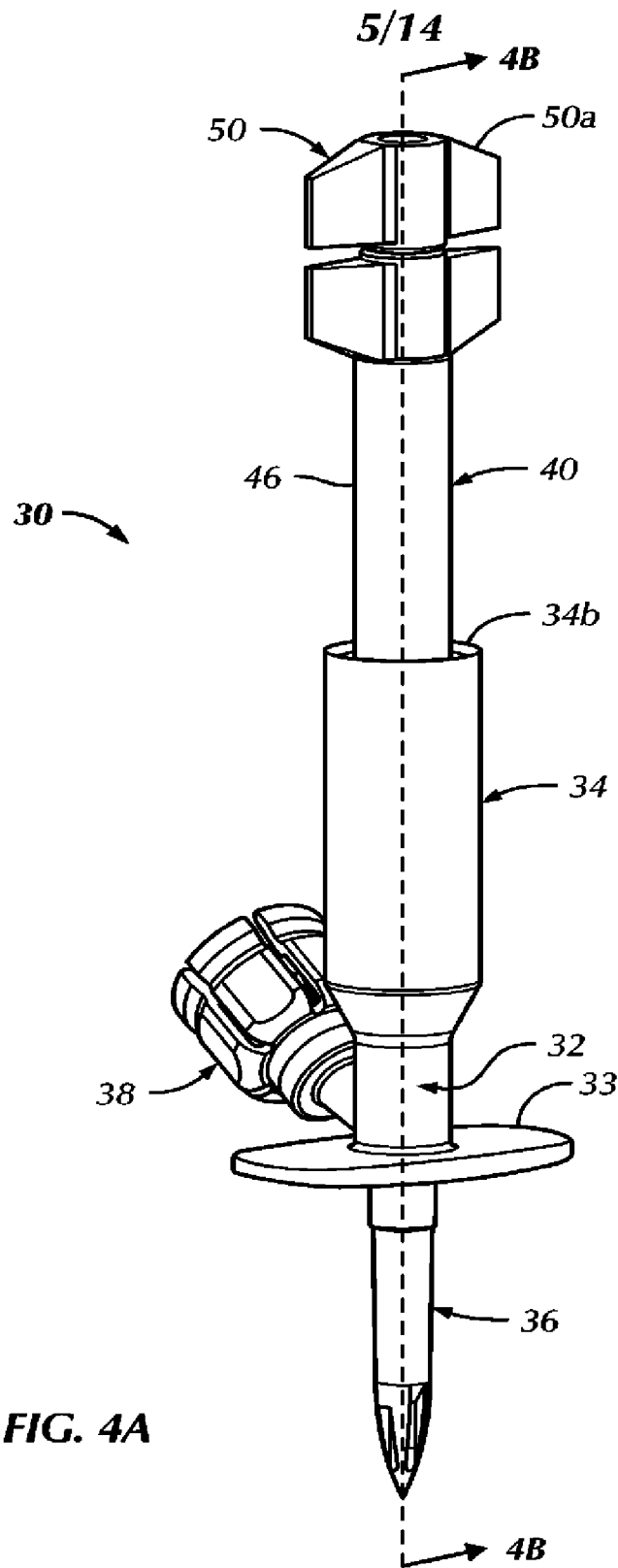
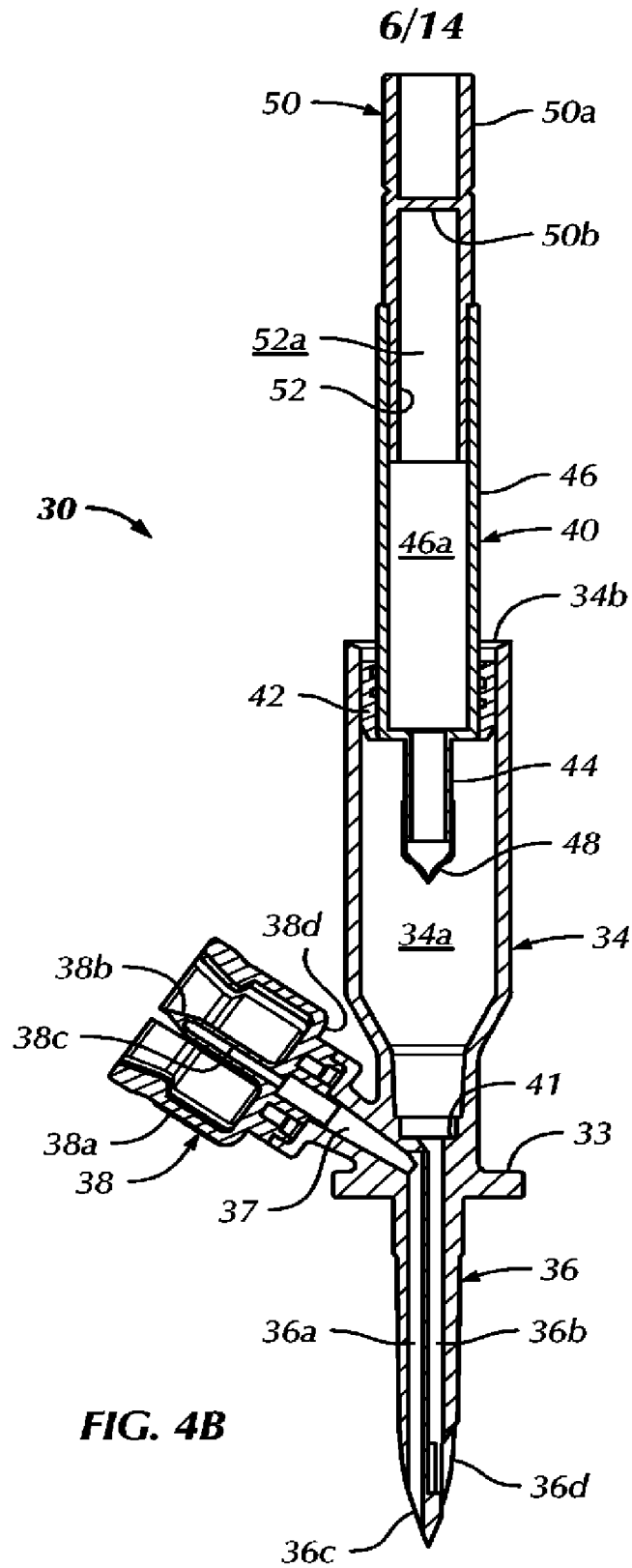
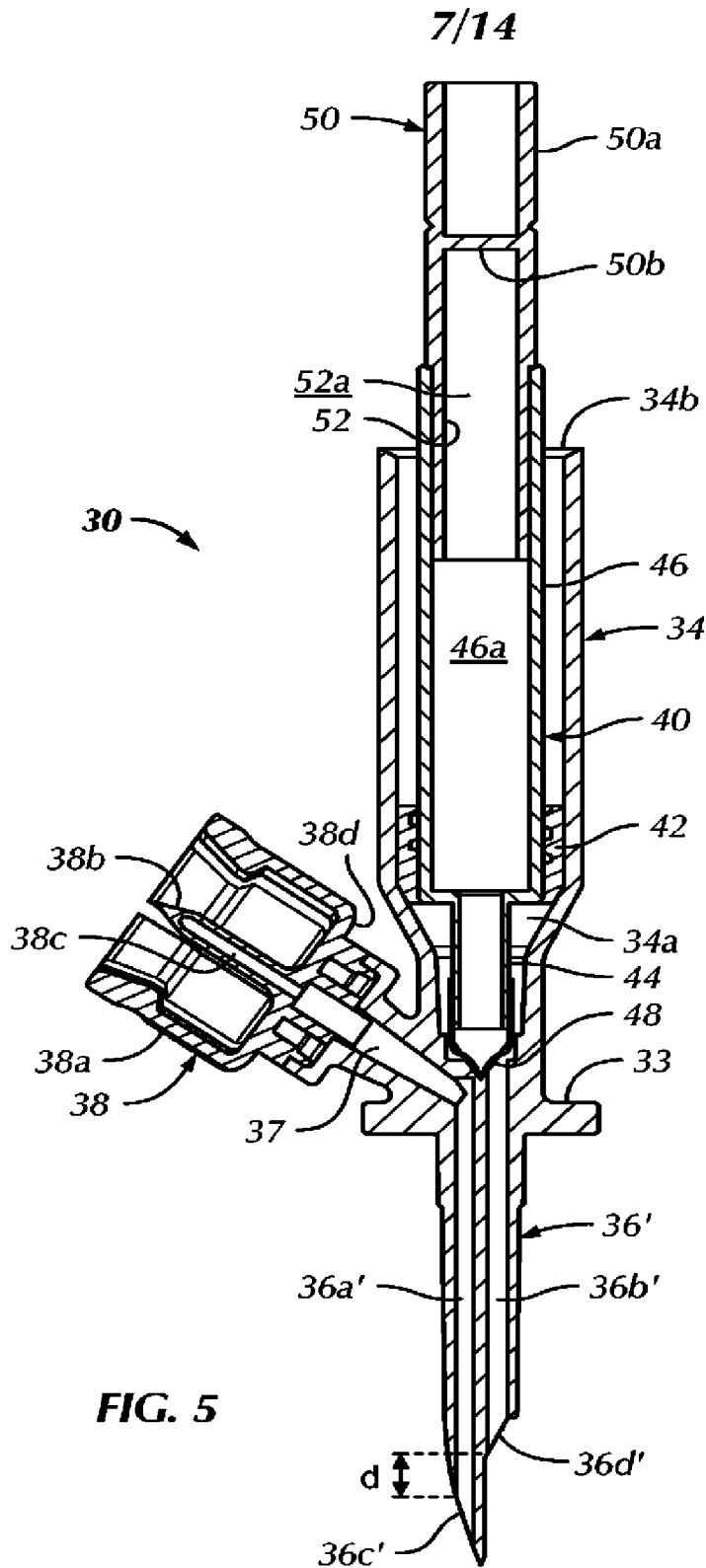

FIG. 4A







9/14

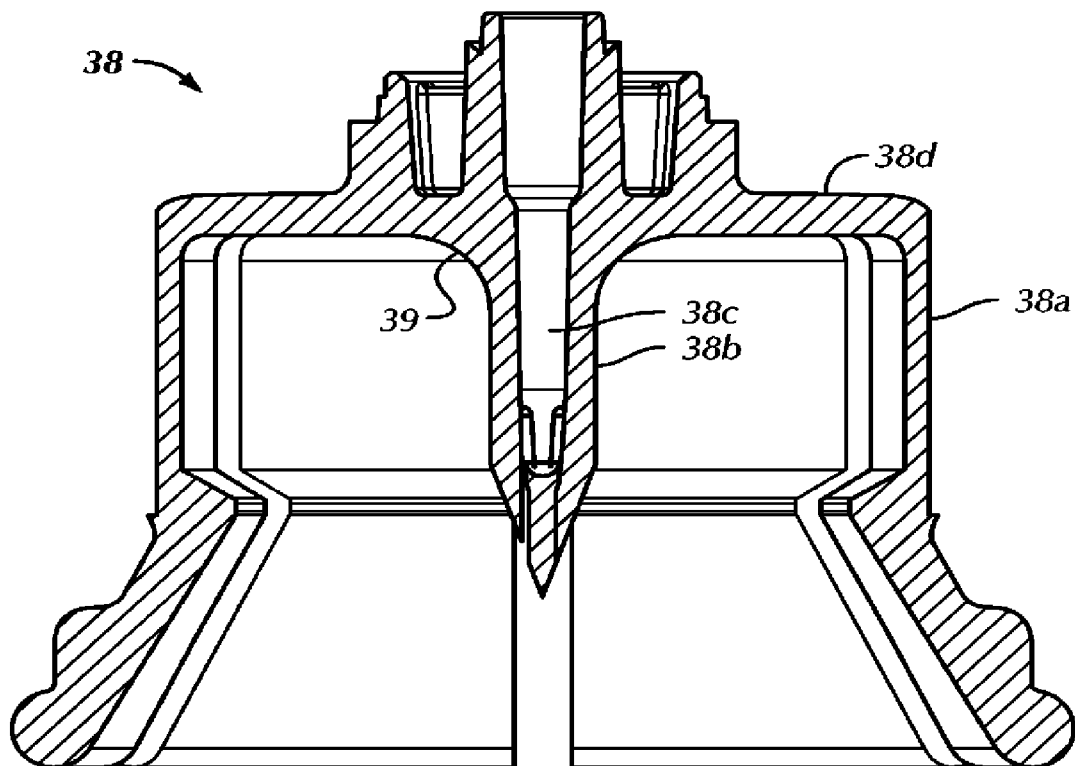

FIG. 7A

10/14

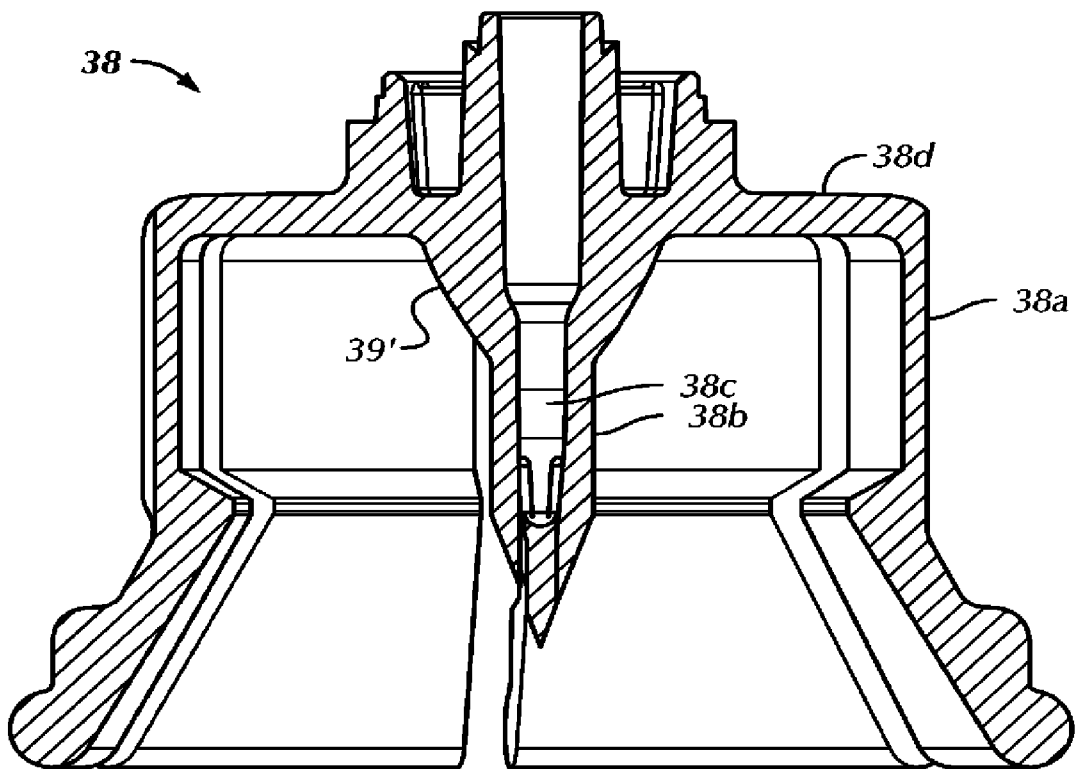

FIG. 7B

11/14

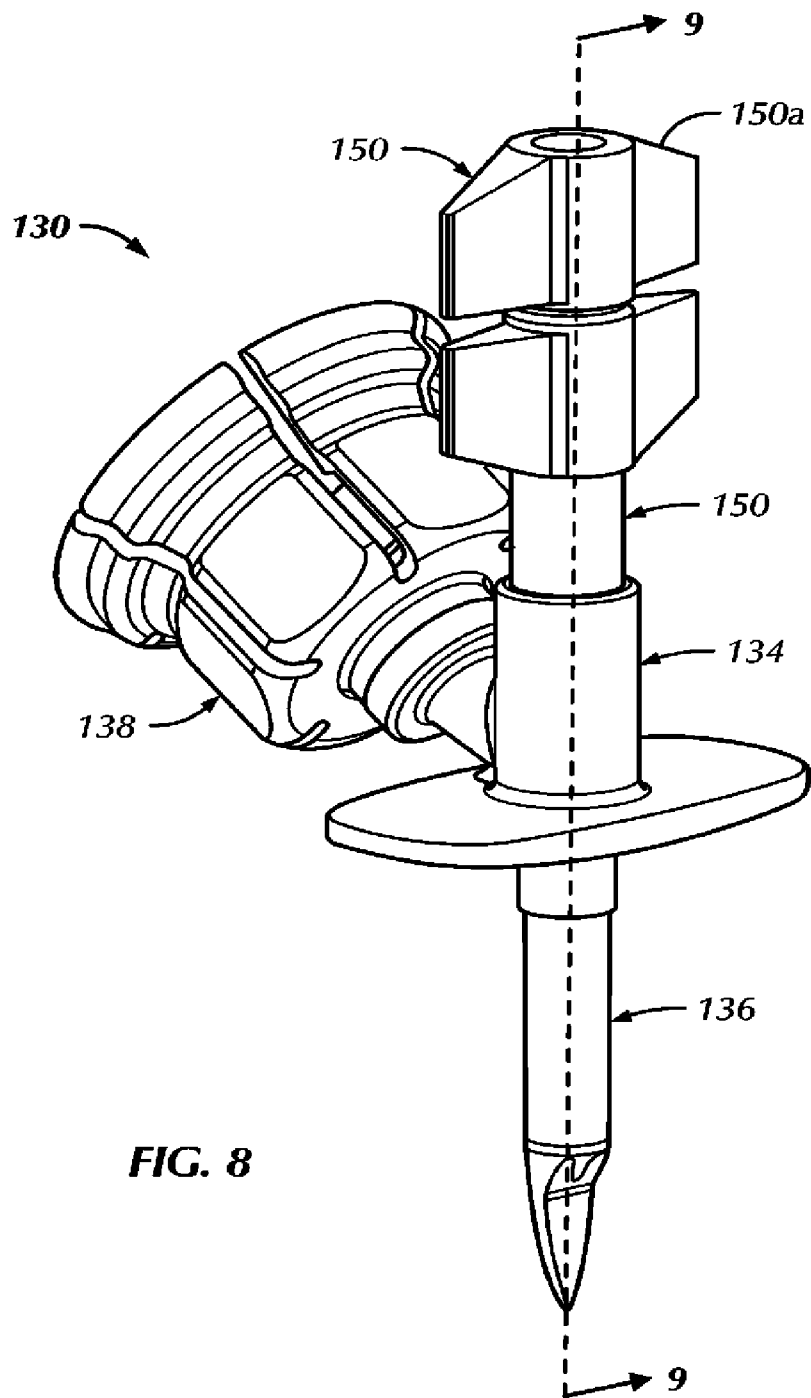

FIG. 8

12/14

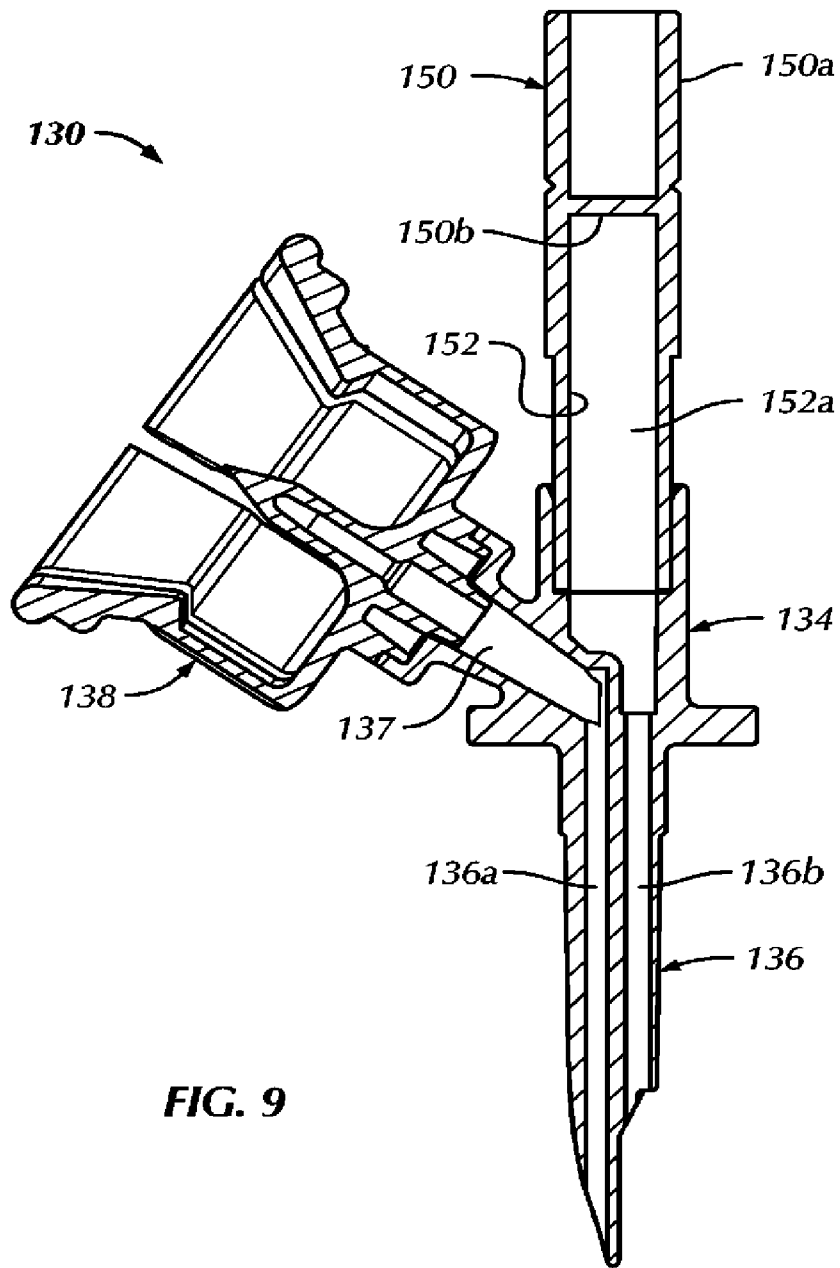

FIG. 9

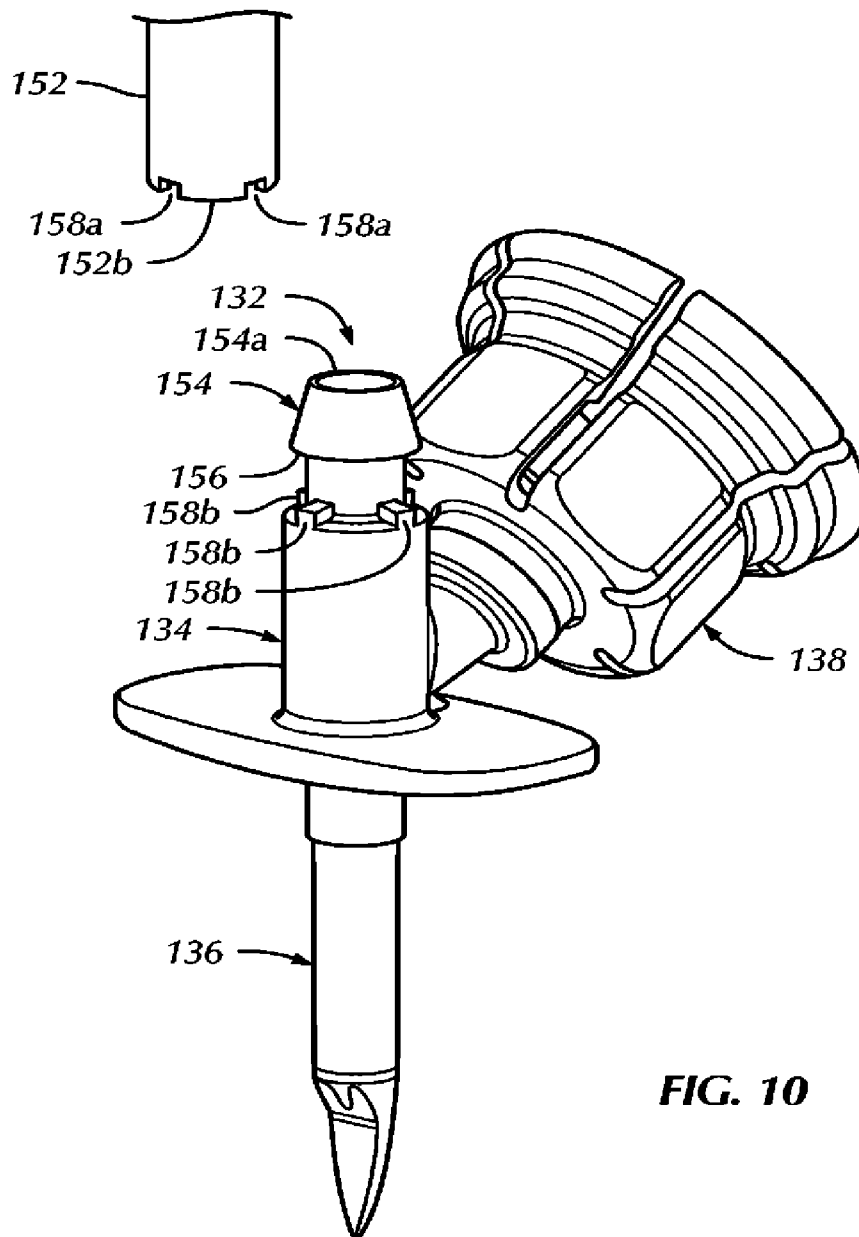

FIG. 10

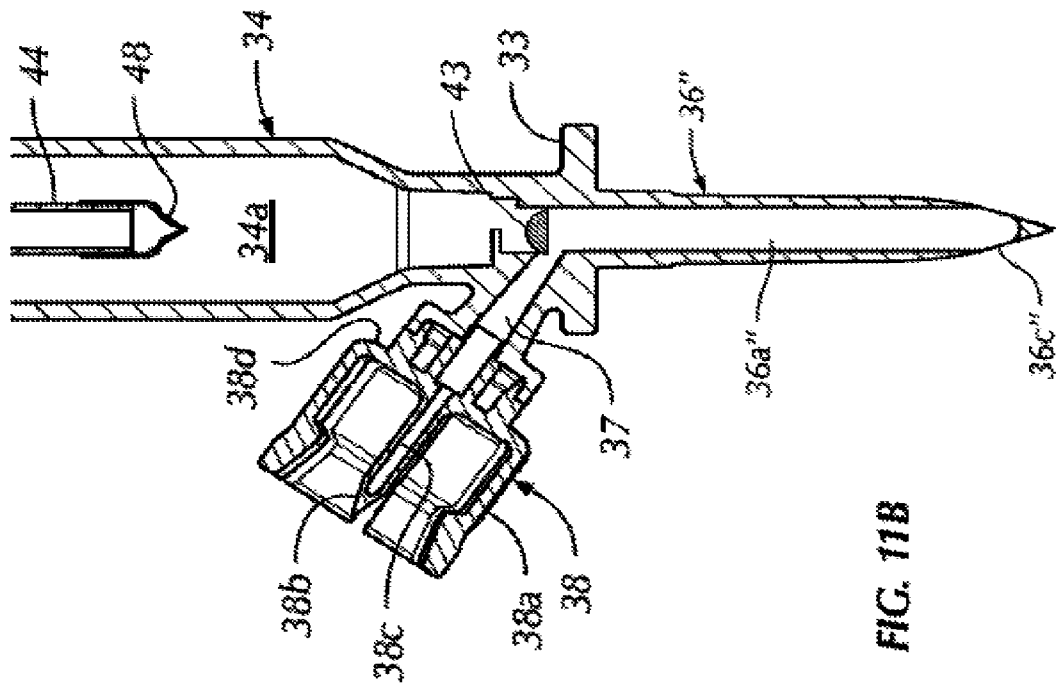

FIG. 11B

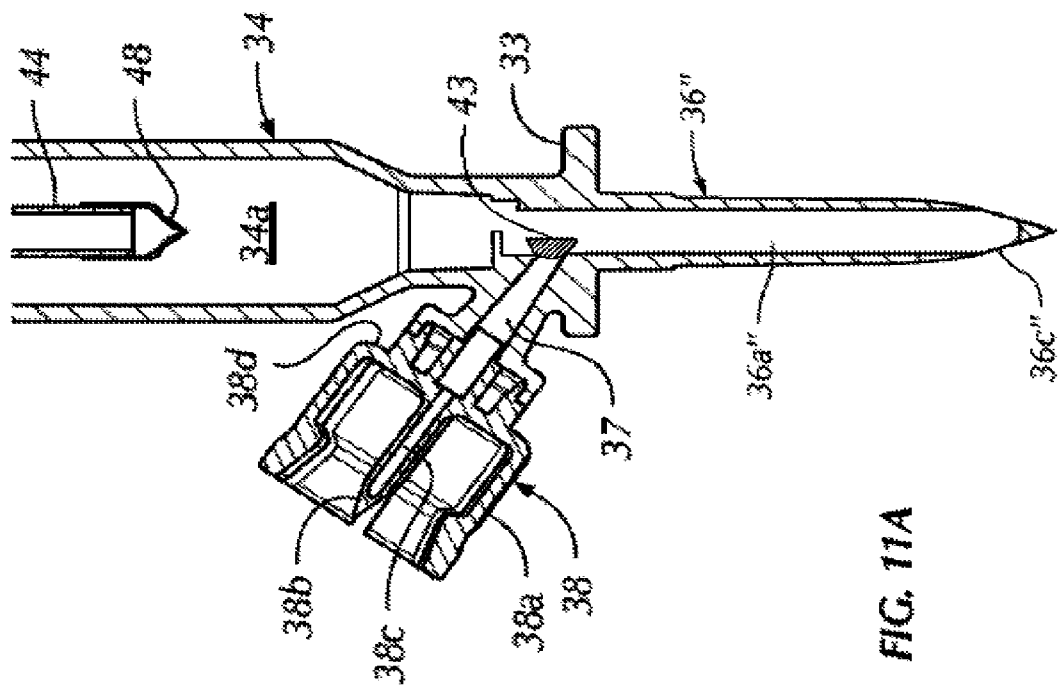
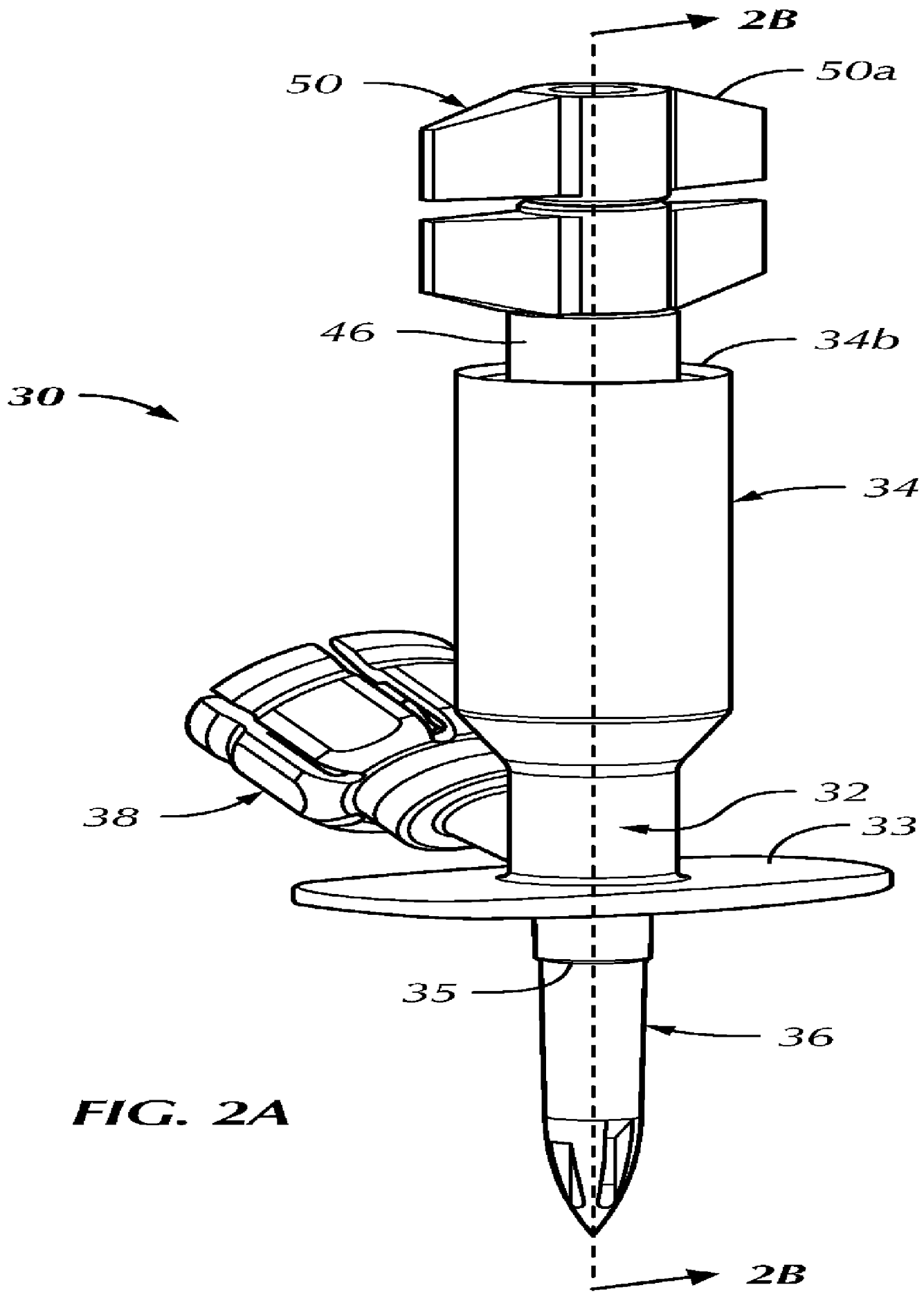

FIG. 11A



**FIG. 2A**