

J. Thomas,

Furnace Protecting.

No. 100,566.

Patented Mar. 8. 1870.

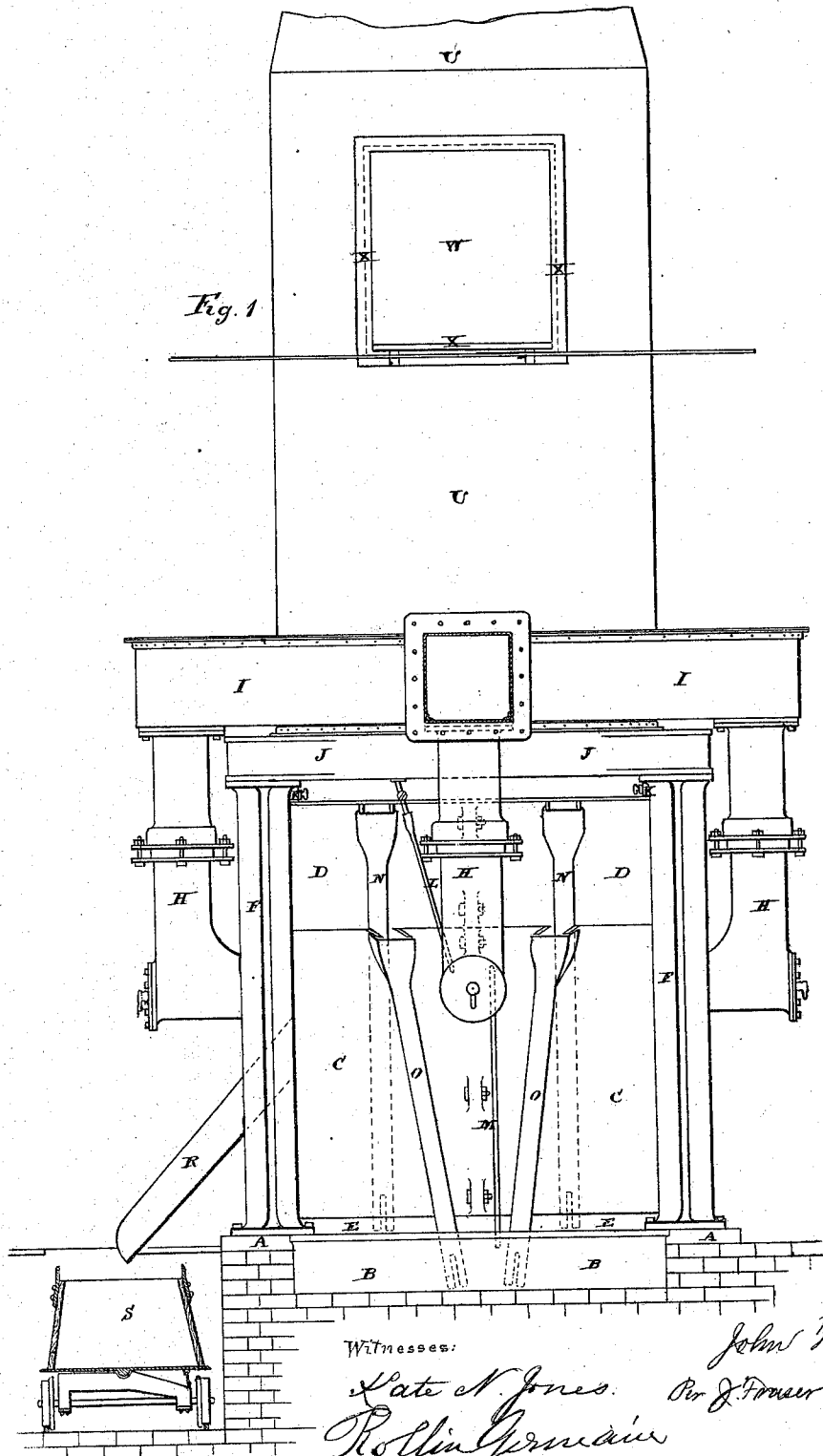

Witnesses:

Wm. H. Jones.
Rollin Germain

John Thomas
Per J. F. Finner Co., Atty

J. Thomas,

Furnace Protecting.

No. 100566.

Patented Mar. 8. 1870.

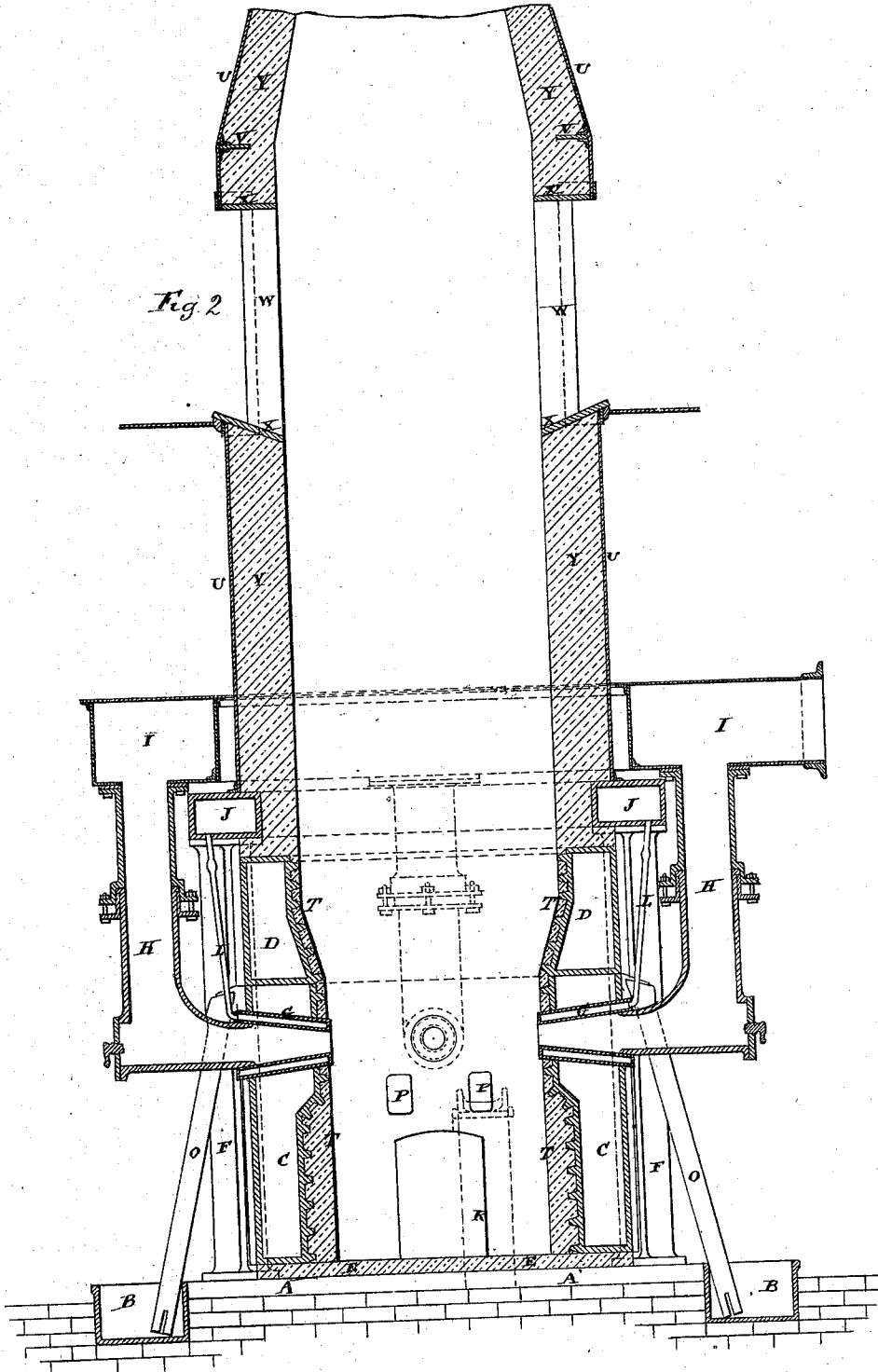

J. Thomas,

3, Sheets, Sheet 3.

Furnace Protecting.

No. 100566.

Patented Mar. 8, 1870.

Fig. 3.

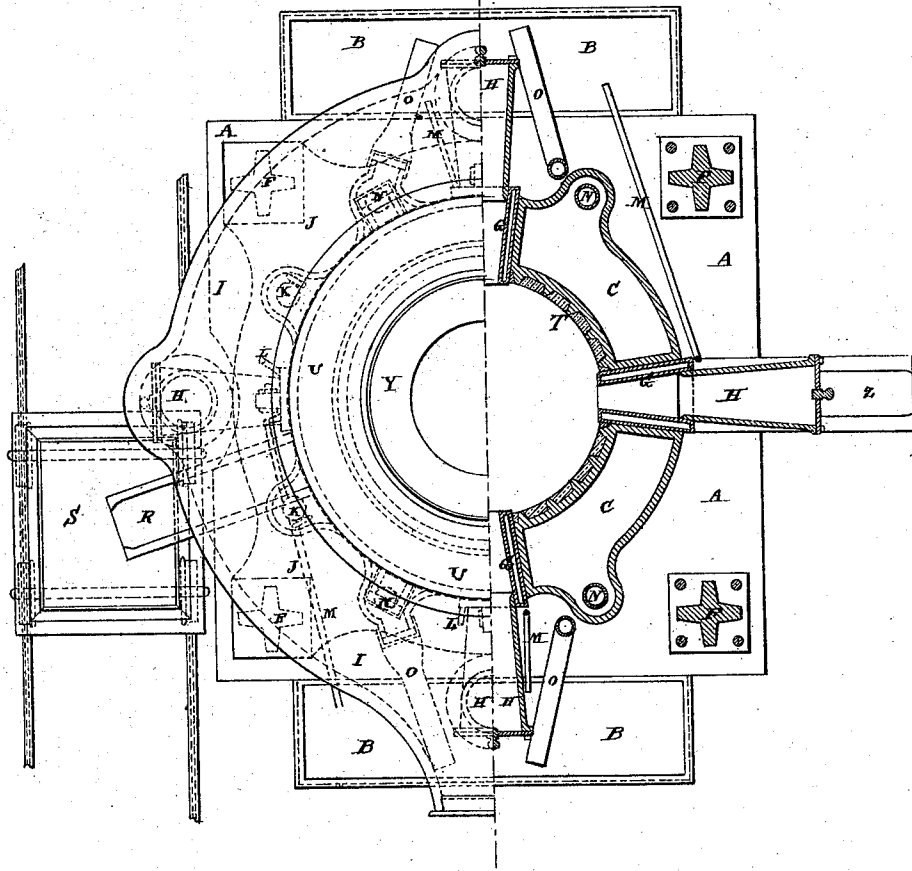

UNITED STATES PATENT OFFICE.

JOHN THOMAS, OF MIDDLESBROUGH, ENGLAND, ASSIGNOR TO HIMSELF, WM. BACON, HARRISON GROVES, AND HUGH CHAYTOR, OF SAME PLACE.

IMPROVEMENT IN FURNACES FOR SMELTING AND FOR OTHER PURPOSES.

Specification forming part of Letters Patent No. 100,566, dated March 8, 1870.

To all whom it may concern:

Be it known that I, JOHN THOMAS, of Middlesbrough, England, have invented certain new and useful Improvements in Furnaces for Smelting and Melting; and I do hereby declare the following to be a true, full, and exact description thereof, reference being had to the accompanying drawings, and to the letters and figures marked thereon—that is to say:

The chief object of my invention is to construct air or blast furnaces which will the better withstand the action of heat and scouring-fluxes in the melting of iron, copper, or other metals, or in the smelting of iron ores, copper ores, or slags, or scoria, or other ores containing metals.

The main features of my invention, in addition to the general arrangement or combination of the parts, are the construction of water-boshes, as hereinafter described, and the employment of spikes on the water-boshes, as hereinafter described.

These improvements will be fully understood by the following description and drawings hereunto annexed, of which—

Figure 1 is a side elevation, Fig. 2 a sectional elevation, and Fig. 3 a plan, one-half being in transverse section, of a furnace constructed according thereto.

A A is the foundation-plate of the furnace. B B are waste-water tanks. C C are bottom water-boshes, set back, say, four and a half inches from the face of the furnace. D D are top water-boshes, set back, say, one and a half inch. The water-boshes C C and D D are spiked inside, as shown, with spikes, say, one and a half inch long, to hold up a lining of fire-clay or other suitable material. E E is a row of fire-brick. F F are pillars supporting the water-entablature. G G are blast-tuyeres. H H are blast-pipes. I I is the blast-entablature. J J is the water-entablature. K K are pipes for taking the water from the entablature J to the boshes. L L are pipes for taking the water into the tuyeres. M M are pipes for taking the waste water from the tuyeres. N N are pipes for taking the water from the top boshes, D D, to the bottom boshes, C C. O O are pipes for taking the waste water from

the boshes. P P are slag-holes. R is the slag-spout; S, the slag-boggy. T T is the lining, of fire-clay or other suitable material. U U is the casing of the chimney. V V are plates to hold up the brick-work. W W are the charging-holes. X X are plates of cast-iron around the charging-holes to protect the brick-work. Y Y is the brick-work inside the chimney. Z is the metal-spout.

The spiked boshes C D hold up the lining, which cannot be fluxed away on account of the water in the boshes keeping the back of the lining comparatively cool. In some cases I dispense with the spikes on the bottom boshes, D. These furnaces may be made round or square, or of any other desired form. For air or reverberatory furnaces for smelting copper ores or other ores of metals, I build the bed of the furnace in the usual way up to and within four or six inches of the bottom, and then set the spiked water-boshes around the sides and bridge of the furnace, and line up against the spikes, as in the cupola or blast furnace. For a puddling-furnace for puddling cast-iron into wrought-iron, I set the spiked water-boshes around the sides and bridge of the furnace, as in the copper-smelting furnace. The spiked water-boshes also apply to gas and steam furnaces.

What I claim as my invention, and desire to secure by Letters Patent, is—

1. The construction and arrangement of water-boshes having spikes cast or otherwise formed on their inner sides, in the manner and for the purpose substantially as herein set forth.

2. In combination with the said spiked water-boshes, the water-entablature J, pipes K, pipes N, and pipes O, arranged and acting substantially as herein set forth, and shown in the annexed drawings.

In witness whereof I, the said JOHN THOMAS, have hereunto set my hand this 26th day of November, 1869.

JOHN THOMAS.

Witnesses:

JOHN THOMAS, Jr.,
St. Paul's Terrace, Middlesbrough.
R. G. BACON,
Pairlion, Redcar, England.