

No. 837,763.

PATENTED DEC. 4, 1906.

E. C. WILLIAMS.
TYPE HIGH PLANER.
APPLICATION FILED MAY 27, 1905.

6 SHEETS—SHEET 1.

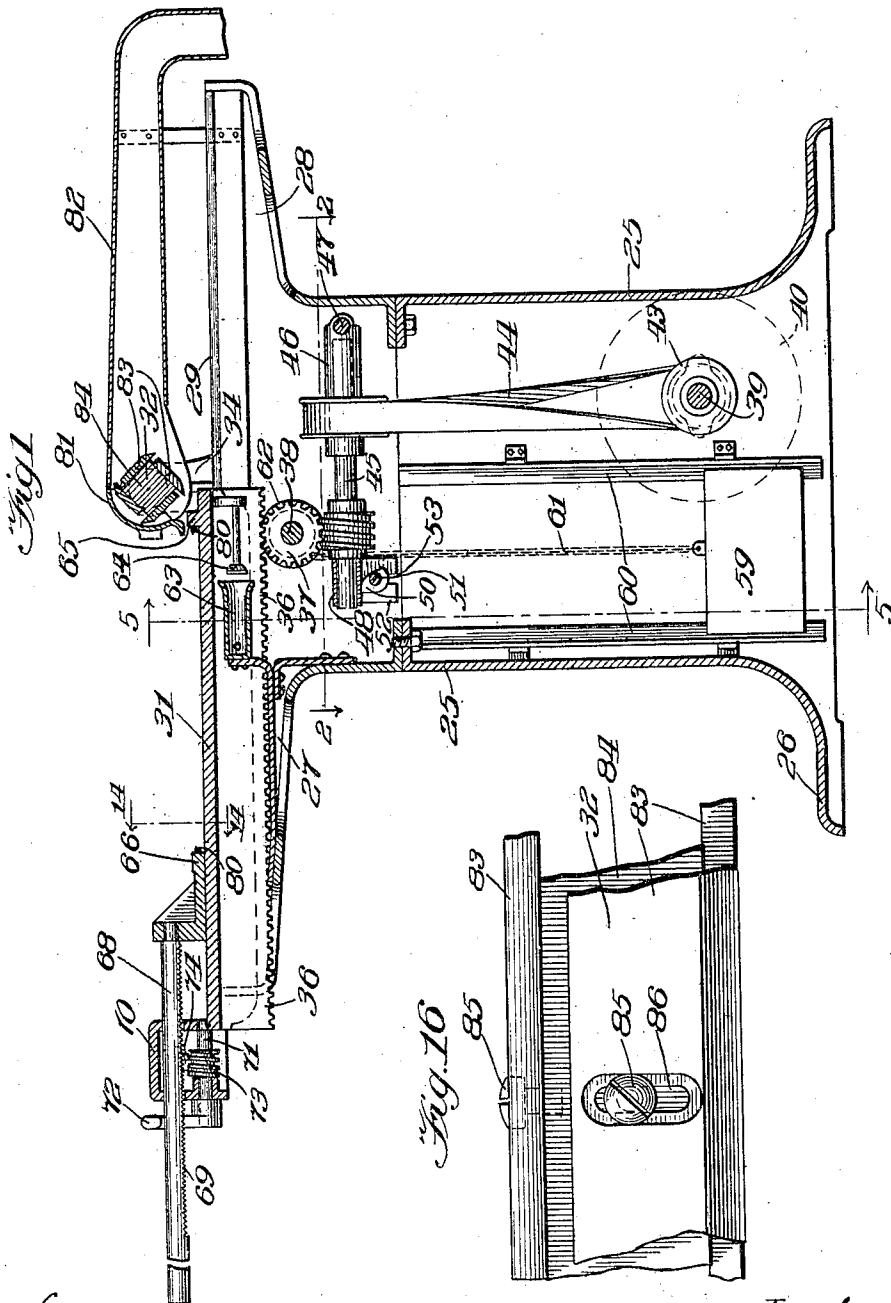

Witnesses:

Wm. A. Yagle.

Charles B. Gilson.

Inventor:

Edward C. Williams.

by Louis A. Lacey
Atty

No. 837,763.

PATENTED DEC. 4, 1906.

E. C. WILLIAMS.
TYPE HIGH PLANER.
APPLICATION FILED MAY 27, 1905.

6 SHEETS—SHEET 2.

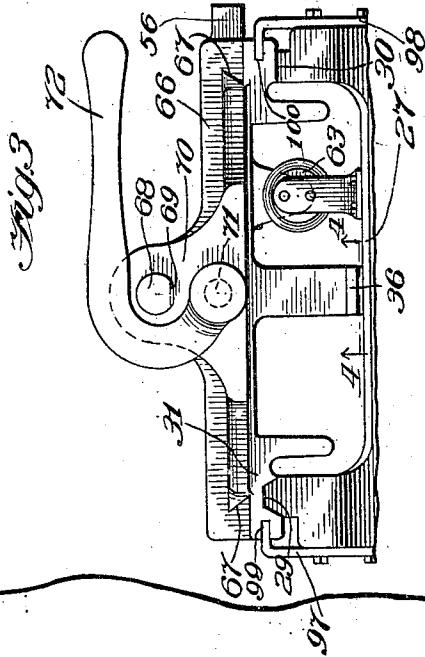
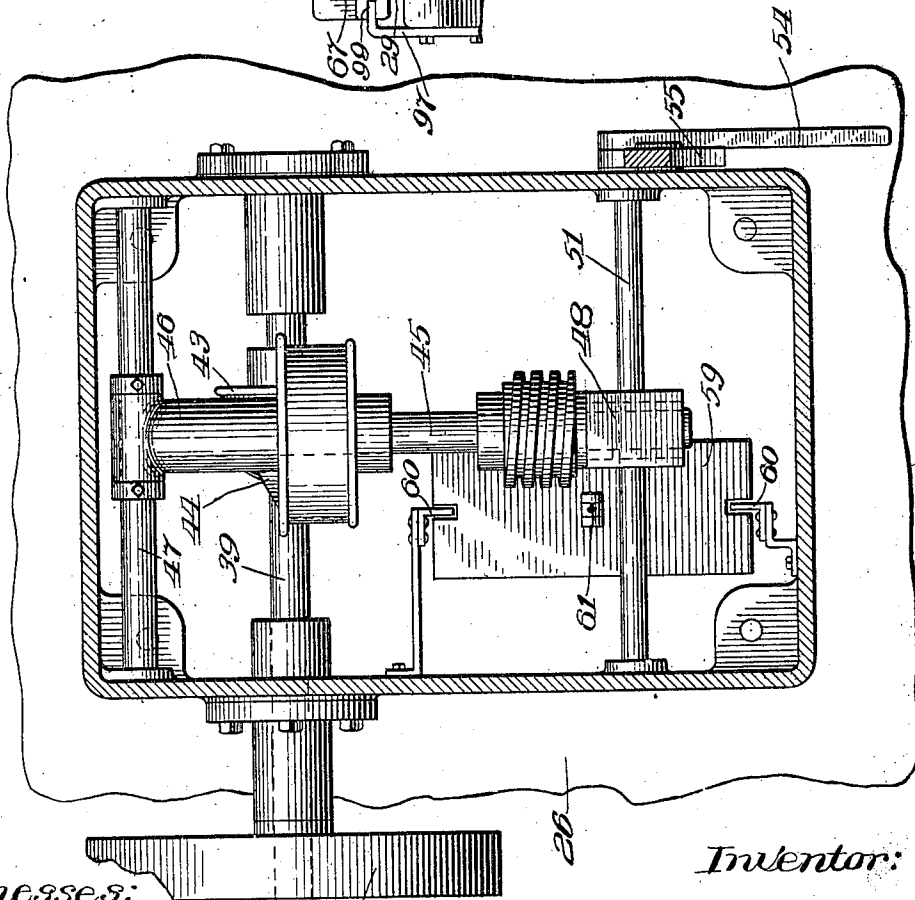

Fig. 2.



Witnesses:
 Wm. H. Yale.
 Charles B. Gillson.

Inventor:
 Edward C. Williams.
 by Louis A. Lison Atty.

No. 837,763.

PATENTED DEC. 4, 1906.

E. C. WILLIAMS.
TYPE HIGH PLANER.
APPLICATION FILED MAY 27, 1905.

6 SHEETS—SHEET 3.

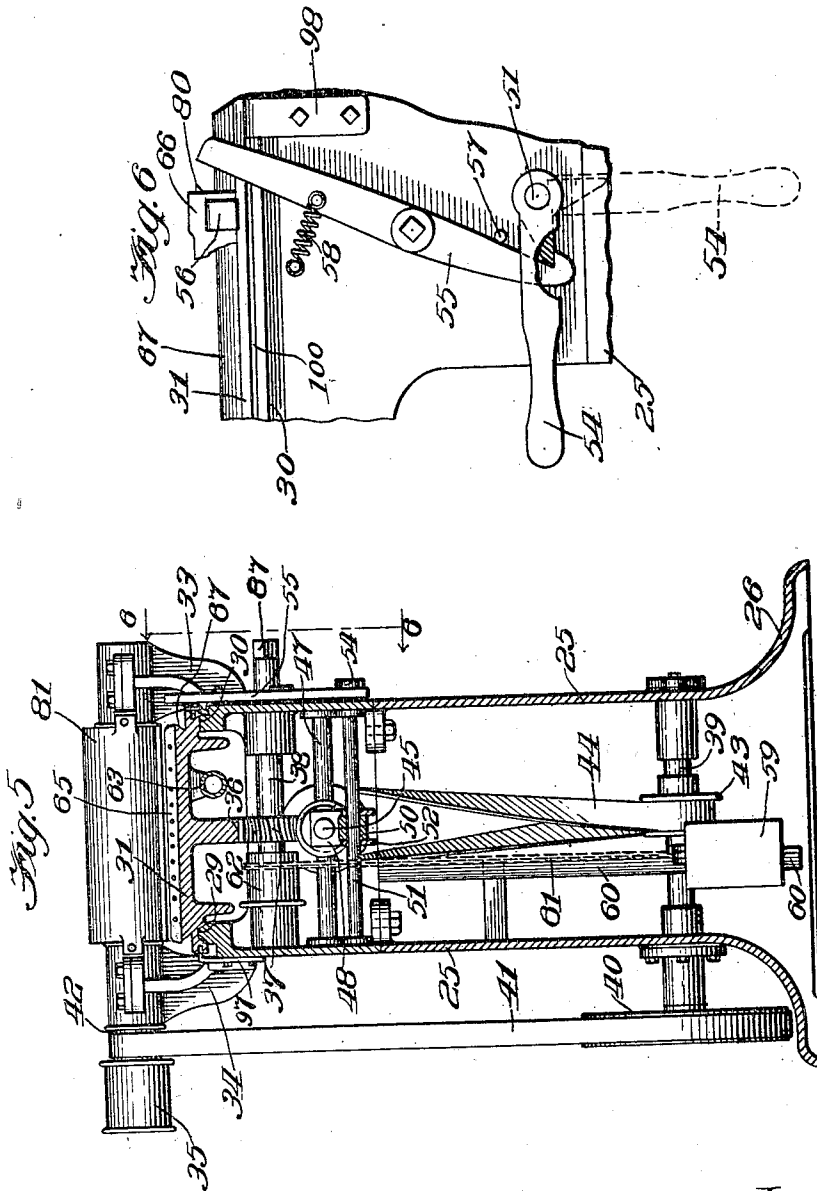

Witnesses:
Wm. H. Yagle.
Charles B. Gillson.

Inventor:
Edward C. Williams
by *Lewis G. Green*
ATTY.

No. 837,763.

PATENTED DEC. 4, 1906.

E. C. WILLIAMS.
TYPE HIGH PLANER.
APPLICATION FILED MAY 27, 1905.

6 SHEETS—SHEET 6.

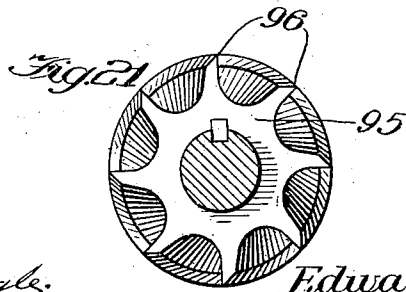
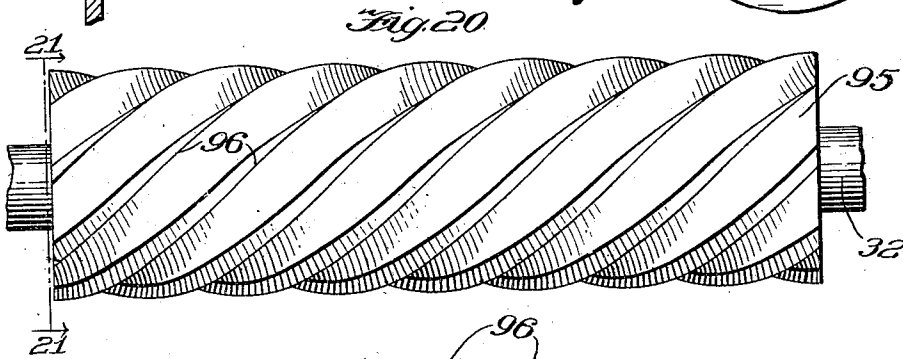
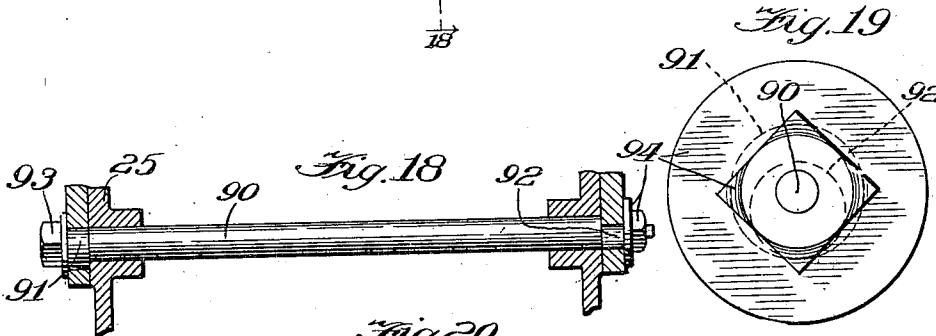
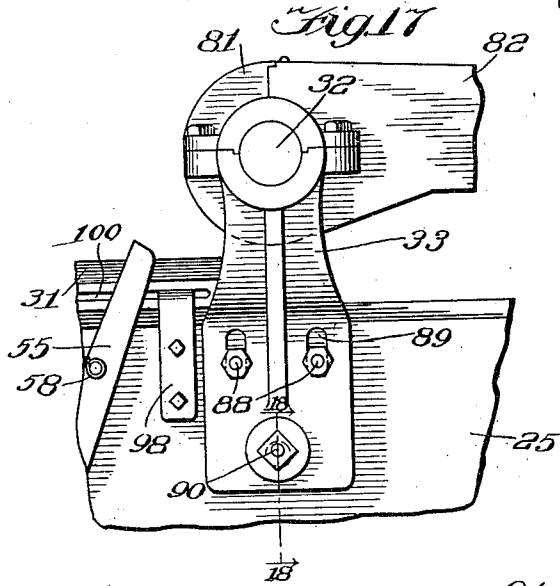

Witnesses:
Wm. H. Yagle.
Charles B. Gillson.

Inventor:
Edward C. Williams.
by Louis G. Gieson
Atty.

UNITED STATES PATENT OFFICE.

EDWARD C. WILLIAMS, OF CHICAGO, ILLINOIS, ASSIGNOR TO UNITED PRINTING MACHINERY CO., A CORPORATION OF MAINE.

TYPE-HIGH PLANER.

No. 837,763.

Specification of Letters Patent.

Patented Dec. 4, 1906.

Application filed May 27, 1905. Serial No. 262,584.

To all whom it may concern:

Be it known that I, EDWARD C. WILLIAMS, a citizen of the United States, and a resident of Chicago, county of Cook, and State of Illinois, have invented certain new and useful Improvements in Type-High Planers, of which the following is a specification and which are illustrated in the accompanying drawings, forming a part thereof.

The invention relates to a planing-machine intended to reduce a block to a standard height.

More particularly the invention relates to a machine adapted for reducing a printing-block, by planing off its back, to the correct height for use in conjunction with other type.

In the preparation of type having a wooden body, especially such type which is formed by providing a wooden block with a printing-surface by applying to one of its faces a prepared metal plate, such as an electrotype, it has heretofore been difficult to accurately obtain the required height or thickness. As the printing-surface of such a block could not be made to pass the feed-rolls of the ordinary form of planing-machine without being injured thereby, it has been the usual practice to prepare the block to the required height before mounting the metal plate thereon. When this is done, the printing quality of the resulting type depends, therefore, on the degree of accuracy obtained in securing the two together.

It is now intended to prepare type of this class by first securing the prepared printing-plate to a block of greater thickness, by an indifferent amount, than is required and then to reduce the printing-block so formed to the desired height by planing off the back of the block.

To this end the invention contemplates a device having a planer-head adapted to be rapidly revolved, a work-table having a smooth surface for receiving the face of the type and capable of being advanced beneath the planer-head, and a vise for securing the block in position upon the table.

The object of the invention is to provide a planing-machine of simple and durable construction and one which shall afford means for preparing a block of a predetermined height with superior accuracy.

The invention consists in the construction

and arrangement of parts to be hereinafter described, and as illustrated in the accompanying drawings, in which—

Figure 1 is a central longitudinal section of the machine. Fig. 2 is a plan section on the line 2 2 of Fig. 1. Fig. 3 is a detail end view of the machine. Fig. 4 is a bottom plan of a detail of the machine as viewed from the line 4 4 of Fig. 3. Fig. 5 is a transverse section on the line 5 5 of Fig. 1. Fig. 6 is a detail elevation as viewed from the line 6 6 of Fig. 5. Figs. 7, 8, and 9 represent details shown in Fig. 1 drawn to a larger scale, Figs. 7 and 8 illustrating different positions of the same parts and a portion of Fig. 7 being drawn in vertical cross-section for the purpose of showing the interior construction. Fig. 10 is a detail section on the line 10 10 of Fig. 9. Fig. 11 is similar to Fig. 10, but shows a different position of the parts. Fig. 12 illustrates a detail of the machine separated from other parts. Fig. 13 is a detail plan view of the machine. Fig. 14 is a sectional detail on the line 14 14 of Fig. 1. Fig. 15 is a detail section on the line 15 15 of Fig. 13. Fig. 16 is a detail elevation of the cutting-tool used on the machine. Fig. 17 is a detail side elevation of the machine, showing a modification in the construction. Fig. 18 is a sectional detail on the line 18 18 of Fig. 17. Fig. 19 is an end view of one of the parts shown in Fig. 18, drawn to a larger scale. Fig. 20 is an elevation of a modified form of cutting-tool used on the machine, and Fig. 21 is a sectional view on the line 21 21 of Fig. 20.

A suitable standard or frame for the machine is shown at 25. It is preferably of chambered form and is provided with a flaring base 26. At its top the side walls are extended longitudinally in either direction, as indicated at 27 28, and upon the upper edges of these side walls ways 29 30 are formed for carrying a reciprocatory work-table 31. This table is movably held to its seat upon the ways by means of the holddowns 97 98, rising from the standard 25 and engaging, respectively, a slotted aperture 99 100, formed in the edges of the table.

A planer-head 32 of usual construction is supported transversely over the work-table 31 and in such a position that its cutting-plane is removed from the surface of the table a certain distance, preferably exactly

equal to the standard height of type. This head is journaled in brackets 33 34, rising from the base 25, and carries a belt-pulley 35 at one of its ends, by means of which it may be rapidly revolved. For advancing the work-table 31 beneath the revolving blade there is formed upon the under side of the table and preferably along its median line a gear-rack 36, which may have inclined teeth, Fig. 4, adapted to be engaged by a spiral gear 37, mounted on a shaft 38, which extends entirely across the chamber of the base of the machine and is journaled in its side walls and which is driven from other revolving parts in the following manner: A counter-shaft 39 is journaled in the standard 25 near its base. It extends through one of the side walls thereof and carries upon its outer end a belt-pulley 40 for receiving a belt 41, which turns over a small pulley 42, formed about the journal of the planer-head 32. This counter-shaft carries a second belt-pulley 43 within the chamber of the standard 25 and drives, by means of a belt 44, turning over this pulley, a worm-shaft 45, movable into and out of engagement with the spiral gear 37. To this end the worm-shaft 45 is adapted to swing and is therefore preferably journaled at one of its ends in a sleeve 46, pivotally supported upon a tie-rod 47, secured in the side walls of the standard 25. Its other end turns in a bearing 48, which rides upon a cam 50, carried by a cam-shaft 51, extending across the chamber of the standard 25 and journaled in its side walls. The bearing 48 is provided with wings 52, which straddle the cam 50, and are slotted, as at 53, to receive the shaft 51 to prevent the displacement of the bearing. The cam 50 and shaft 51 are adapted to be manually rotated to raise the worm-shaft 45 into engagement with the spiral gear 37 and to be automatically released, so that the counter rotation of the cam and shaft and the disengagement of the worm and wheel may be effected by gravity. The mechanism provided for this purpose includes a weighted handle 54, secured to one of the ends of the cam-shaft 51 and adapted to be supported, when in the raised position, by a trigger 55, pivotally secured to the frame of the machine and designed to be operated to release the handle 54 by an appurtenance 56 of the advancing work-table. The movement of the trigger is limited by a stop 57, set into the side of the machine, and the trigger is yieldingly held against the stop and in the correct position to engage the weighted handle by means of a spring 58.

The return of the work-table is accomplished by effecting a counter rotation of the shaft 38 and spiral gear 37, as follows: A weight 59, running in suitable vertical guides 60, supported within the chamber of the standard 25, is raised during the advance of the table by means of a cable 61, which turns

over a drum 62, formed upon the shaft 38. When the worm 45 becomes disengaged from the spiral gear 37, the weight descends and rotates the shaft to return the work-table. This return movement is checked near the end of its stroke by means of a cushioning-cylinder 63, supported from the frame of the machine in the path of a plunger 64, carried by the table.

For securing the material to be operated upon to the work-table a vise is provided and is carried by the table. It includes a fixed jaw 65, secured to the table adjacent its forward end, and a movable jaw 66, having preferably a dovetailed engagement with the floor of the table, as indicated at 67, Fig. 3. From the movable jaw an operating-rod 68 extends backwardly along the median line of the table and has formed upon its under side a series of transverse teeth 69, adapted to be engaged by clamping mechanism mounted upon the table and which is most clearly shown in Figs. 9 to 12, inclusive. This clamping mechanism is carried by an arm 70, which rises from the back of the table to form a loop and is apertured to receive the rod 68. A cam-shaft 71 is journaled between the arms of this loop and may be rotated by means of a handle 72. The cam which is carried by this shaft takes the form of an eccentric worm 73 and is adapted to reciprocate a cam-block 74, having formed upon its upper face a series of transverse teeth 75, complementary to those formed upon the under face of the rod 68. A spring 76, Fig. 12, is mounted upon the face of the cam-block 74 and loosely engages a longitudinal recess 77 in the face of the rod 68 to depress the cam-block, so that the teeth 75 come out of engagement with those of the rod when the cam 73 is turned to the position illustrated in Fig. 11.

The engagement between the cam-block 74 and the cam 73 is through a foot 78, depending from the cam-block and riding in the eccentric groove of the cam loosely, so as to afford clearance or "backlash" 79, Fig. 9, between these parts equal to the width of one or more of the teeth 75, formed on the face of the block. This construction provides that while the cam-shaft 71 is so rotated as to advance the movable parts of the vise and while the foot 78 is therefore bearing upon the advancing face of the cam-groove 73 the movable jaw of the vise is advanced farther than it will be retracted before the teeth of the cam-block and the rod 68 become disengaged when the cam-shaft 71 is rotated in the opposite direction and the depending foot 78 is dragging upon the retracting face of the cam-groove 73. It will be understood, therefore, that by a series of oscillations of the cam-shaft 71 the movable jaw of the vise may be advanced by a series of short steps with great power. If, however, this shaft is turned to

the position of Fig. 11, the cam-block 74 is entirely disengaged from the rod 68 and the movable jaw of the vise may be easily and quickly shifted to any position along the floor of the work-table independently of the mechanism just described.

The jaws of the vise are preferably provided with independent teeth, as 80, set into their opposed faces. These teeth are more numerous near the center of the jaws, Figs. 13 and 14, to provide for taking a firm hold on either a narrow or a wide block without materially increasing the force necessary for clamping the wider block, and each is provided with an inclined under face 80^a, Fig. 15, intended to draw the block down onto the face of the table by a cam action as it is forced into its edge.

A guard 81 is provided for the planer-head, it being attached to the brackets 33 and 34, in which the head is journaled, and a chute 82, preferably of sheet metal, is secured to the guard and is adapted to conduct the planer-chips over the end of the machine.

In using the machine the block to be operated upon is placed face down upon the smooth surface of the work-table 31 and clamped in position between the jaws of the vise. This is quickly accomplished if the movable jaw 66 is grasped by the hand and advanced upon the block until the teeth 80 of both the fixed and movable jaws take a bearing upon the edges of the block, which may now be rigidly secured in position by moving the handle 72 back and forth to oscillate the cam-shaft 71 and advance the movable jaw of the vise, as previously described. Usually it will be necessary to advance the operating-handle 72 but once, and when this handle is completely advanced the movable jaw is locked in position, owing to the gradual incline of the cam-groove 73. The back of the block is now planed off by the operation of the machine. Assuming the planer-head to be continuously rotated from a belt (not shown) turning over the pulley 35, the table is set in motion by raising the handle 54 until it is engaged by the trigger 55. The table 31 will then be advanced by the rotation of the spiral gear 37 until the stop 56, carried by the table, engages the trigger 55 to release the weighted handle 54, when the cam-shaft 51 will be rotated by the descent of the handle to the position shown by dotted lines in Fig. 6 and permit the disengagement of the worm 45 and spiral gear 37. The worm-shaft 38 will then be rotated in the opposite direction by the descent of the weight 59 and the table 31 returned to the original position, being brought to a gradual but positive stop at the end of the stroke by the cushioning-cylinder 63.

The extent of the advance of the table is controlled by the position of the stop 56, which, being formed integral with the mov-

able jaw 66 of the vise, Figs. 3 and 6, is always so placed in relation to the block operated upon as to arrest the advance of the table as soon as the rear edge of the block has passed beneath the cutting-tool.

The required height of the finished block may be accurately obtained by varying the effective diameter of the cutting-tool 32. This is accomplished by shifting the position of the several blades 83, which are secured to the rectangular frame 84, Fig. 1, by screws, as 85, passing through slots, as 86, in the blades, Fig. 16. It may, however, in some instances be desirable to provide means for shifting the brackets 33 34 for the purpose of adjusting the height of the cutting-tool 32 above the work-table 31. An arrangement for effecting this result is illustrated in Figs. 17, 18, and 19, in which the brackets 33 34 are adjustably secured to the standard 25 by means of bolts 88, passing through slotted apertures 89 in the brackets. A cam-shaft 90 for shifting the brackets extends across the machine below the table 31 and is journaled in the walls of the standard 25. This shaft is provided with eccentric portions 91 92 for engaging the brackets, one of which, as 91, is preferably of less diameter than the shaft for convenience in assembling. A squared head 93 is formed upon one end of the shaft for receiving a suitable wrench, (not shown,) and a nut and washer 94 are applied to the opposite end for maintaining the correct alinement of the parts. To allow for the lateral displacement of the brackets 33 34 by means of the eccentrics 91 92, the apertures 89 are made of greater width than the diameter of the bolts 88.

A modified form of planer-head 95 is shown in Figs. 20, 21. This head is provided with a plurality of spiral cutting edges 96, and when employed in the machine in place of the planer-head 32 the machine may be made to operate either upon type composed entirely of metal or upon type having a wooden body, as may be desired.

The shaft 38 is continued through the wall of the standard 25 at one side of the machine and provided with a squared end 87 for receiving a crank, (not shown,) so that the work-table 31 may be manually advanced, if desired.

The improved form of vise herein shown for securing the work to the table of the machine is not more fully described nor specifically claimed, as it is made the subject of a divisional application for patent, Serial No. 294,276.

I claim as my invention—

1. In a type-high planer, in combination, a revolving planer-head, a table adapted to be advanced beneath the head, a gear-rack formed on the table, a gear for engaging the rack, a worm-shaft driven from the revolving parts of the machine for engaging the

gear to advance the table and adapted to swing, a cam for swinging the worm-shaft, and a weight for returning the table.

2. In a type-high planer, in combination, 5
a revolving planer-head, a table adapted to be advanced beneath the head, a gear-rack formed on the table, a gear for engaging the rack, a worm-shaft driven from the revolving parts of the machine for engaging the 10
gear to advance the table and adapted to swing, a cam for swinging the worm-shaft, an arm for turning the cam, a hook for supporting the arm, a stop carried by the table for engaging the hook, and a weight for re- 15
turning the table.

3. In a type-high planer, in combination, a revolving planer-head, a table reciprocable beneath the head, a gear-rack formed on the table, a gear for engaging the rack, a worm- 20
shaft driven from the revolving parts of the machine for engaging the gear to advance

the table and adapted to swing, a cam for swinging the worm-shaft, an arm for turning the cam, a hook for supporting the arm, a movable work-engaging member carried by 25
the table, and a contact-piece carried by such member for engaging the hook.

4. In combination, a suitable standard, a power-shaft journaled in the standard, a gear journaled in the standard, a worm-shaft for 30
driving the gear, a bearing for the end of the worm-shaft pivotally attached to the standard, a cam journaled in the standard, a saddle-bearing for the worm-shaft resting on the cam, a crank-arm for turning the cam, a pul- 35
ley on the worm-shaft and on the power-shaft, and a belt turning over the pulleys.

EDWARD C. WILLIAMS.

Witnesses:

CHARLES B. GILLSON,
LOUIS K. GILLSON.