

Jan. 15, 1929.

1,699,146

A. W. HULL

ELECTRON DISCHARGE DEVICE

Filed Oct. 3, 1922

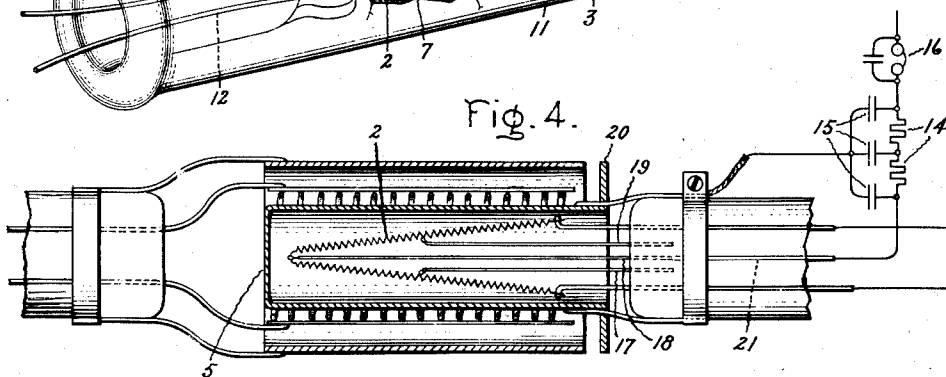
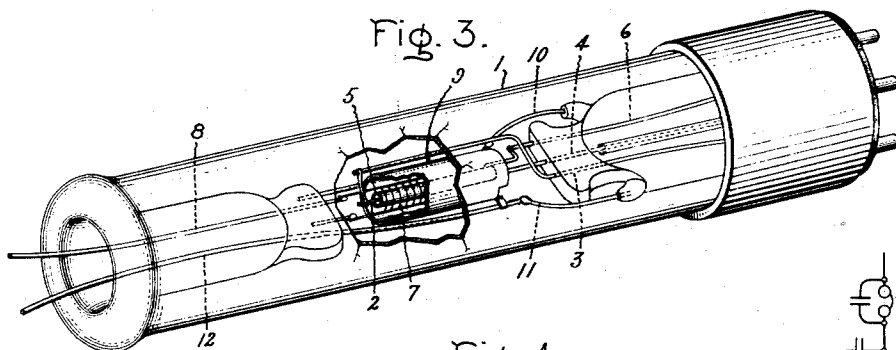
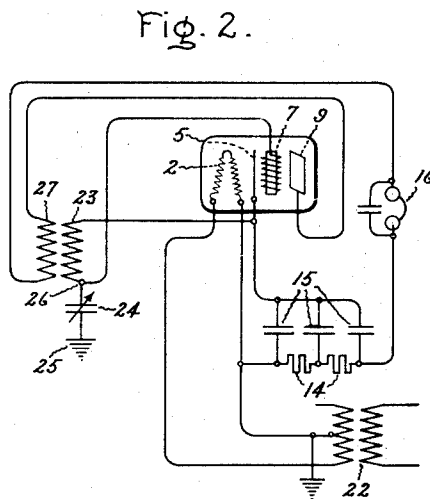
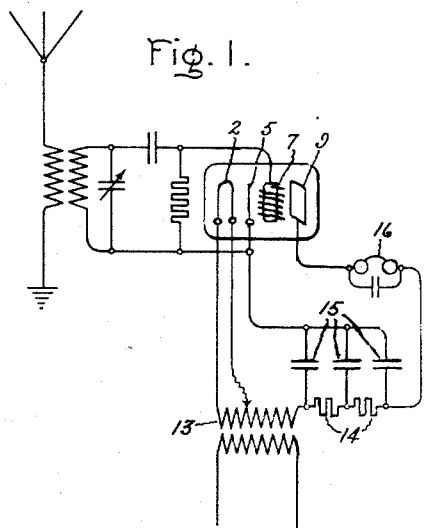

Inventor:
Albert W. Hull,

by *Alexander S. Hunt*
His Attorney.

UNITED STATES PATENT OFFICE.

ALBERT W. HULL, OF SCHENECTADY, NEW YORK, ASSIGNOR TO GENERAL ELECTRIC COMPANY, A CORPORATION OF NEW YORK.

ELECTRON-DISCHARGE DEVICE.

Application filed October 3, 1922. Serial No. 592,158.

My present invention relates to electron discharge devices and the manner in which such devices may be conveniently operated.

The object of my invention is to provide
5 an electron discharge device and a circuit arrangement therefor whereby it will be possible to supply all potentials for the operation of the device from an alternating current source.

10 It has been customary in the past when it has been desired to furnish the operating current for an electron discharge device of the common three electrode type from an alternating current source to employ separate
15 rectifiers for supplying the necessary direct current for the operation of the plate circuit. A more specific object of my invention is to eliminate the necessity of this separate rectifier and to provide a self-contained
20 device certain of the electrodes of which will function to rectify the alternating current for the plate supply, and other electrodes will perform the usual functions of the three electrode device.

25 The novel features which I believe to be characteristic of my invention are set forth with particularity in the appended claims. My invention itself however will best be understood by reference to the following description taken in connection with the accompanying drawing in which Figs. 1 and 2
30 show diagrammatically two forms of radio receiving circuits with which my device may be employed. Fig. 3 shows in perspective with some of the parts broken away one form of device constructed in accordance with my invention, and Fig. 4 is a cross-sectional view of the electrodes in a modified form.

40 The device as indicated in Fig. 3 comprises an evacuated receptacle 1, containing a filamentary electrode 2 the ends of which are connected to the leading-in conductors 3 and 4. Surrounding this filamentary electrode
45 there is a cylindrical electrode 5, the outer surface of which is preferably coated with some thermionically active material, so that the outer surface will emit electrons at a relatively low temperature in comparison
50 with the inner surface. This electrode is connected to and supported from leading-in conductor 6. Electrode 5 is in turn surrounded by grid electrode 7 which is connected to the leading-in conductor 8. Grid
55 electrode 7 in turn is surrounded by cylin-

drical anode 9 which is supported by arms 10 and 11 and is connected to leading-in conductor 12.

In the operation of the device such as I have just described, in a circuit arrangement such as that shown in Fig. 1, a source of alternating current such for example as the secondary 13 of a transformer may be provided. A portion of the secondary turns of the transformer are connected with the
60 filamentary electrode 2 for heating the same to incandescence, as a result the surrounding electrode 5 will be heated either by radiation or by bombardment to such a temperature that the outer surface thereof will emit electrons for supplying the space current for the device. In other words, the outer surface of
65 electrode 5 is adapted to serve as cathode in conjunction with the anode 9. The inner surface of the electrode 5 is adapted to act as anode in conjunction with the electrode 2 to rectify the alternating current supplied by source 13. One terminal of the source 13 is connected through resistances 14 to the
70 anode 9. Condensers 15 connected between resistances 14 and the electrode 5 serve in conjunction with these resistances to smooth out fluctuations of the current supply to the plate circuit. The complete path of the current in the plate circuit may be traced from
75 the terminal of source 13 which is connected to the electrode 2, through electrode 2 across the evacuated space to electrode 5, across the evacuated space from electrode 5 to anode 9 and back through the telephone receivers 16
80 to the opposite terminal to source 13. Current can flow in only one direction through this circuit because of the rectifier action taking place between electrodes 2 and 5.

85 The operation of the system may be better understood by considering the action when the anode 9 is not connected to the resistances 14. Under these conditions when an alternating potential is supplied to the transformer secondary 13, and the end of this transformer connected to the cathode 2, is
90 at a negative potential with respect to the other terminal, electrons will flow from the cathode 2 to the electrode 5. There being no complete conductive circuit from the
95 electrode 5 back to the opposite terminal of the transformer 13, no current will flow back to that terminal. The electrons carried across the space to the electrode 5, however, serve to charge the condensers 15 con-
100
105
110

nected thereto and thus build up a potential between the terminals of the condensers. During the succeeding half cycle when the end of the transformer 13 to which the cathode 2 is connected is positive with respect to the other end, no electrons will flow across the space between 2 and 5, but the accumulated charge will remain on the condensers 15. During the succeeding half cycle electrons will be carried over to the electrode 5 and the charge on the condensers will be increased. Since the electrons cannot flow in the opposite direction from the electrode 5 to the cathode 2 there is no conductive path whereby the charge can leak off the condensers, and this charge will be built up until the electrode 5 acquires a negative potential substantially equal to the maximum negative potential of the electrode 2.

If now the anode 9 is connected to the resistances 14, as indicated, current will be caused to flow from the electrode 5 over to the anode 9. During the periods when electrons are flowing to electrode 5 some of the electrons will furnish current across the evacuated space to the anode 9 and some of them will add to the charge on condensers 15. During the half cycle when no electrons are furnished to electrode 5 the charge accumulated on condensers 15 will cause current to flow across the evacuated space from electrode 5 to anode 9. Thus the apparatus is capable of furnishing continuously a direct current across the evacuated space between the electrode 5 and the anode 9, and this current is supplied by reason of the rectifying action between electrodes 2 and 5.

I have shown in Fig. 4 a modified electrode structure which is adapted to be used in cases where it is desired to employ the full voltage of the alternating current source, such for example, as the voltage of the ordinary lighting circuit for the heating of the filamentary electrode 2. The filamentary electrode 2 as shown in Fig. 4 is made in the form of a coiled filament with supporting arms 17, 18, and 19.

The electrode 5 is preferably provided with a flange 20 to prevent electrons emitted from the outer surface thereof finding their way to the filament supports, and also to shield the path of the electrons from the electrostatic fields produced by electrode 2 and its supports. I have indicated the middle filament support 18 as connected to a leading-in conductor 21. By this expedient the device may be employed for rectifying both half waves of the alternating current supply. The manner in which the circuit connections would be made in this case is indicated at the right of Fig. 4.

When a device such as that described is connected to an ordinary lamp socket it may

be desired to employ the lighting circuit as a receiving antenna. The manner in which this may be done is indicated in Fig. 2. In practice it will usually be found that some point in the lighting circuit will be grounded as for example the mid point of the secondary of transformer 22 which supplies current to the house lighting circuits as indicated in Fig. 2. If such is the case the portion of the lighting circuit between this ground and the lamp socket may be used as a receiving antenna by connecting electrode 5 through inductance 23 and variable capacity 24 to ground at 25 and connecting grid 7 to point 26 as indicated. By reason of the large capacities 15, electrode 5 will have impressed thereon substantially the full high frequency potential of the lighting circuit. Regenerative amplification may be obtained by means of a feed back coil 27 connected in the plate circuit and coupled to inductance 23.

While the electrode 5 as before stated is preferably so constructed that in the course of normal operation it will not emit electrons from the inner surface, this condition is not essential in all cases. In the arrangement of Fig. 4 for example satisfactory operation may be obtained if the electrode 2 emits enough more electrons than the inner surface of electrode 5 to provide by the excess sufficient plate current.

What I claim as new and desire to secure as Letters Patent of the United States, is,—

1. The combination of an electron discharge device comprising an electrode which is adapted to be heated, an electrode surrounding said first electrode and adapted to serve as a cathode, a control electrode and an anode, and an electrical circuit connected between said first electrode and said anode, said circuit including an alternating current source having one terminal connected to said first electrode and its other terminal connected to said anode, said source of alternating current constituting the sole source of current supply for said circuit.

2. An electron discharge device comprising a filamentary electrode, a second metallic electrode surrounding said first electrode and having its outer surface adapted to emit electrons at a relatively low temperature compared with its inner surface, a control electrode outside said second electrode and an anode outside said control electrode, a source of alternating current connected to said filamentary electrode for heating the same and a connection between a selected point on said source and said anode.

3. An electron discharge apparatus comprising an electrode adapted to be heated, a second metallic electrode surrounding said first electrode, a control electrode outside of said second electrode, and an anode outside of said control electrode, said second elec-

trode being connected in a circuit arrangement to serve as anode in cooperation with said first electrode and to serve as cathode in cooperation with said anode, a source of alternating current connected to said first electrode for heating the same, and circuit connections whereby said first two electrodes serve to rectify alternating current derived from said source and thereby cause said alternating current to be rectified and as rectified to flow in the path through the device between the second electrode and the anode.

4. An electron discharge device comprising a filamentary electrode, a second metallic electrode surrounding said first electrode and having its outer surface adapted to emit electrons at a relatively low temperature compared with its inner surface and an anode outside of said second electrode, a source of alternating current connected to said filamentary electrode for heating the same and a connection between a selected point on said source and said anode.

5. An electron discharge apparatus comprising an electrode adapted to be heated, a second metallic electrode surrounding said first electrode, and an anode outside of said second electrode, said second electrode being connected in a circuit arrangement to serve as anode in cooperation with said first electrode and to serve as cathode in cooperation with said anode, a source of alternating current connected to said first electrode for heating the same, and circuit connections whereby said first two electrodes serve to rectify alternating current derived from said source and thereby cause said alternating current to be rectified and as rectified to flow in the path through the device between the second electrode and the anode.

6. The combination of an electron discharge device comprising an electrode adapted to be heated, a second electrode adjacent thereto which is connected to serve as a cathode and a cooperating anode, and an electric circuit connected between said first electrode and said anode, said circuit including an alternating current source having one terminal connected to said first electrode and its other terminal connected to said anode, said source of alternating current constituting the sole source of current supply for said circuit.

7. The combination of an electron discharge device comprising an electrode adapted to be heated, three electrodes surrounding said first electrode, one of which is connected to serve as cathode, and a second of which is connected to serve as anode in conjunction with said cathode, and the third of which is connected to serve as control electrode, a source of alternating current connected to said first electrode for heating it to incandescence, and a connection

between a selected point on said source and one of said surrounding electrodes, said connection being so made that the first electrode and one of the surrounding electrodes serve to rectify current derived from said source and thereby cause said alternating current to be rectified and as rectified to flow in a path through the device which includes the other two electrodes.

8. An electron discharge apparatus comprising an electrode adapted to be heated by the passage of current, a second electrode adjacent thereto having a surface remote from the first electrode adapted to emit electrons at a relatively low temperature compared with its surface adjacent said first electrode, an anode located to receive electrons from said second cathode, a source of alternating current connected to said first electrode for heating the same, and a connection from a selected point on said source to said anode.

9. An electron discharge apparatus comprising an electrode adapted to be heated by the passage of current, a second electrode adjacent thereto and an anode located to receive electrons from the second electrode, said second electrode being connected to serve as anode in cooperation with said first electrode and to serve as cathode in cooperation with said anode, a source of alternating current connected to said first electrode for heating the same and circuit connections whereby said first two electrodes serve to rectify alternating current derived from said source and thereby cause said alternating current to be rectified, and as rectified to flow in a path through the device which includes the anode.

10. An electron discharge device comprising an electrode adapted to be heated, a second electrode adjacent thereto having a surface remote from said electrode adapted to emit electrons at a relatively low temperature compared with its surface adjacent said first electrode, and an anode located to receive electrons from said second electrode, a source of alternating current connected to said first electrode for heating the same to produce an emission of electrons therefrom and a connection from a selected point on said source to said anode.

11. The combination of an electron discharge device comprising an electrode adapted to be heated and three other electrodes, one of which is connected to serve as a cathode, a second of which is connected to serve as anode in conjunction with said cathode, and the third of which is adapted to serve as control electrode, a source of alternating current connected to said first electrode for heating the same to produce an emission of electrons therefrom and a connection between a selected point on said source and one of said other electrodes, said

connection being so made that the electrode adapted to be heated and one of the other electrodes serve to rectify current derived from said source and thereby cause said alternating current to be rectified and as rectified to flow in a path through the device which includes the other two electrodes.

12. The combination of an electron discharge device comprising a cathode adapted to be heated and at least two other electrodes one of which is connected to serve as a cathode and a second of which is connected to serve as an anode in conjunction with said cathode, a source of alternating current connected to said first named electrode for heating it to produce an emission of electrons therefrom and a connection between a selected point on said source and one of said other electrodes, said connection being so made that the heated electrode and one of the other electrodes serve to rectify current derived from said source and thereby cause said alternating current to be rectified, and as rectified to flow in a path through the device which includes the second of the other electrodes.

13. An electron discharge apparatus comprising amplifying means and rectifying means in a unitary device, said amplifying means having a cathode which is connected to serve as an anode for the rectifying means, a source of alternating current and means for connecting said source to the apparatus in such a way that the rectifying means serves to rectify the current from said source and supply unidirectional current to the amplifying means.

14. An electron discharge apparatus comprising amplifying means and thermionic rectifying means in a unitary device, said amplifying means having a cathode which is adapted to serve as an anode for the rectifying means, a source of alternating current for supplying heating current for the operation of the rectifying means and means

for connecting said source to the apparatus in such a way that the rectifying means serves to rectify the current from said source and supply unidirectional current to the amplifying means.

15. An electron discharge apparatus comprising an electrode adapted to be heated, a second electrode adjacent thereto and an anode located adjacent said second electrode so as to receive electrons from the second electrode, a source of alternating current having one terminal connected to said first electrode and its other terminal connected to said anode through an impedance which permits the passage of direct current and to the second electrode through a capacity only, said connections serving to cause alternating current from said source to be rectified and as rectified to flow in the path through the device between the second electrode and the anode as a continuous direct current.

16. An electron discharge apparatus comprising an electrode adapted to be heated, a second electrode adjacent thereto and an anode located adjacent said second electrode so as to receive electrons from said second electrode, said second electrode being adapted to serve as anode in cooperation with said first electrode and to serve as cathode in cooperation with said anode, a source of alternating current connected to said first electrode for heating the same and a connection from a selected point on said source to said anode through an impedance which permits the passage of direct current and to said second electrode through a capacity, said connections serving to cause alternating current from said source to be rectified and as rectified to flow in the path through the device between the second electrode and the anode as a continuous direct current.

In witness whereof, I have hereunto set my hand this 2nd day of October, 1922.

ALBERT W. HULL