

L. R. BLAKE. Boot and Shoe Sewing Machine.

No. 201,987.

Patented April 2, 1878.

Fig. 1.

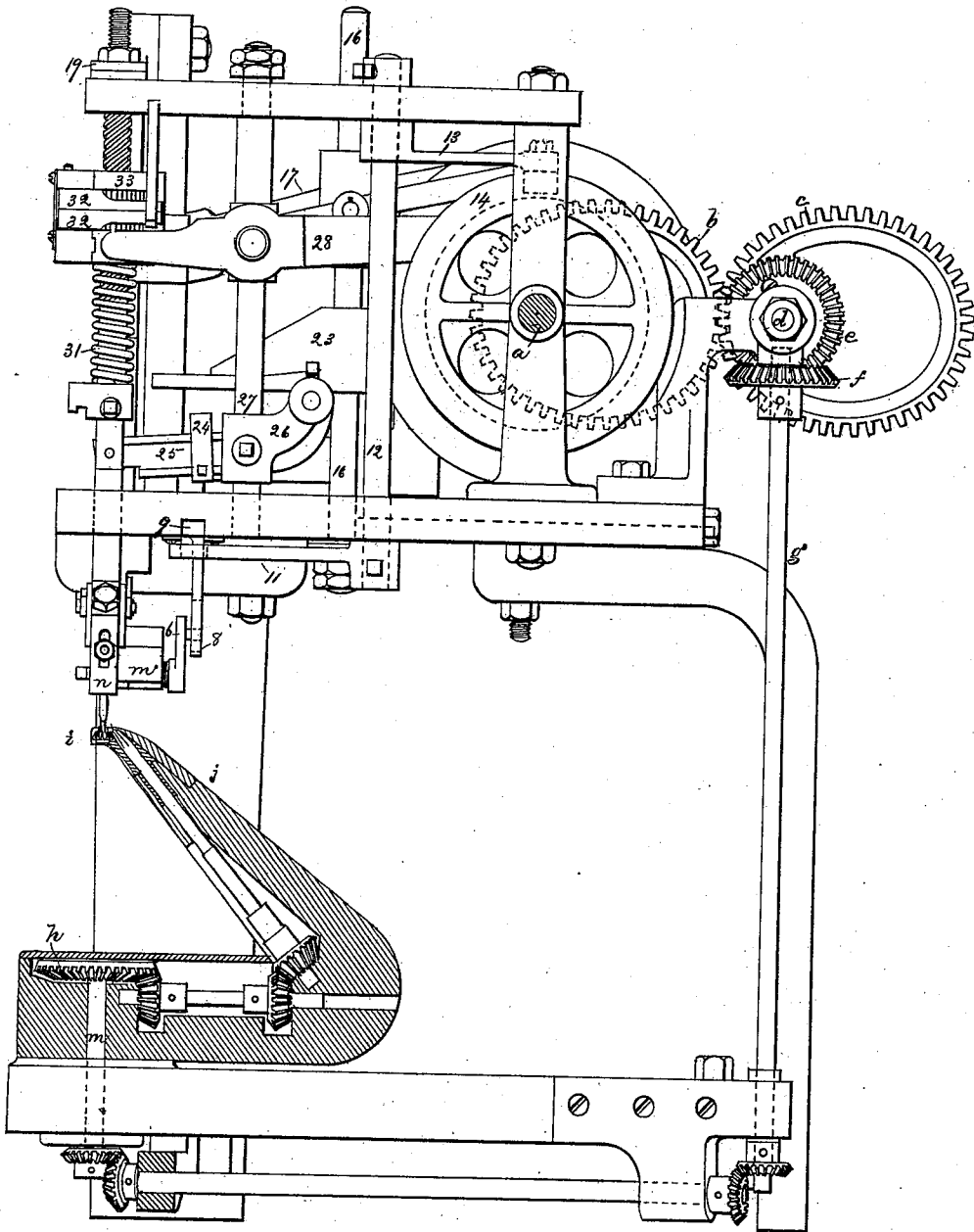

Witnesses.

E. C. Perkins.

W. G. Pratt

Inventor.

*Lyman R Blake
per Crosby & Gregory Att*

Scale 4 in to 1 ft

L. R. BLAKE.
Boot and Shoe Sewing Machine.

No. 201,987.

Patented April 2, 1878.

Fig. 2.

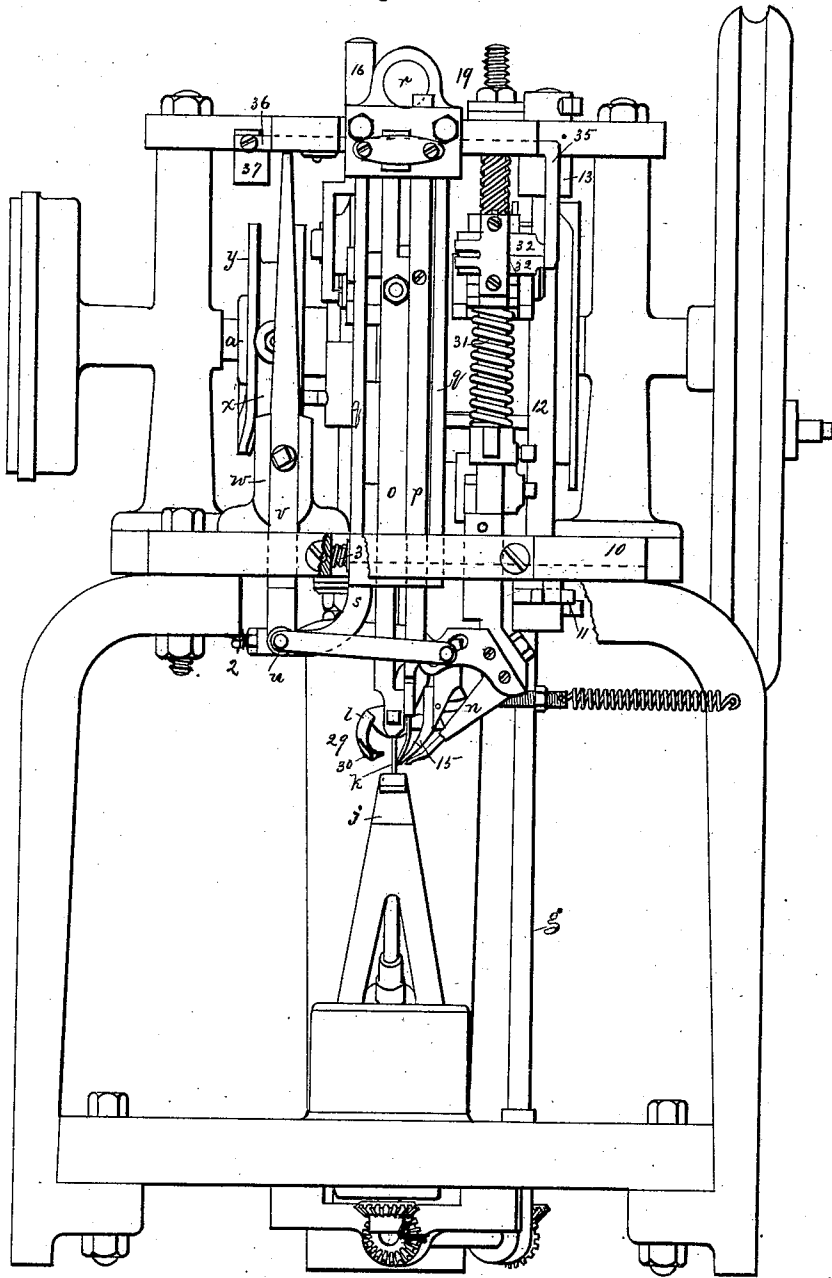

WITNESSES.

E. C. Perkins.

W. J. Pratt.

INVENTOR.

Lyman R. Blake.

per Krosby & Gregory Attys

Scale 4 in to 1 ft

L. R. BLAKE.
Boot and Shoe Sewing Machine.

No. 201,987.

Patented April 2, 1878.

Fig. 3.

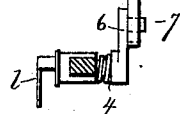
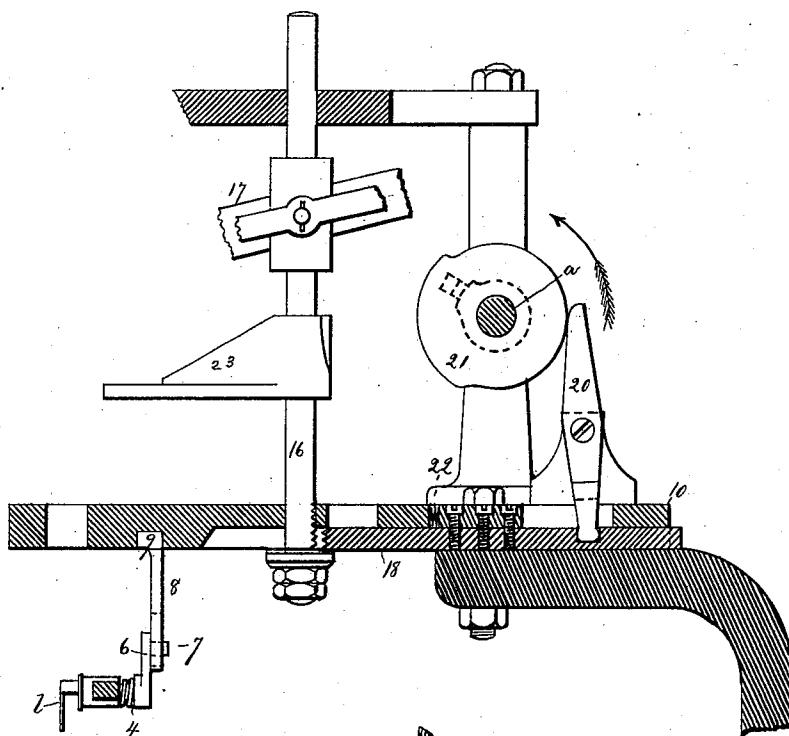

Fig. 4.

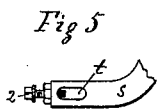
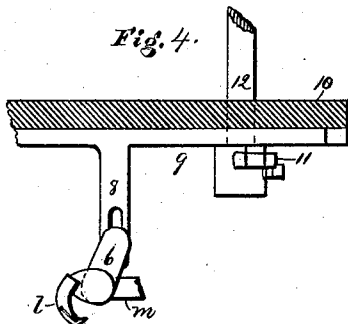

Fig. 5.

Fig. 7.

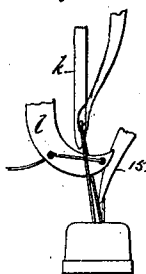

Fig. 8.

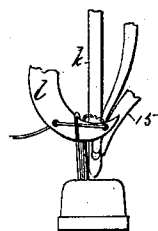
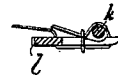

Fig. 6.



WITNESSES.

S. C. Perkins.

W. J. Pratt.

INVENTOR.

Lyman R. Blake

per Crosby Gregory, Att'y.

UNITED STATES PATENT OFFICE.

LYMAN R. BLAKE, OF BOSTON, MASSACHUSETTS.

IMPROVEMENT IN BOOT AND SHOE SEWING MACHINES.

Specification forming part of Letters Patent No. **201,987**, dated April 2, 1878; application filed June 6, 1877.

To all whom it may concern:

Be it known that I, LYMAN R. BLAKE, of Boston, county of Suffolk, and State of Massachusetts, have invented an Improvement in Boot and Shoe Sewing Machines, of which the following is a specification:

This invention relates to sewing-machines for sewing leather.

The invention consists in the combination, with the horn and its whirl and the hooked needle, of eccentric-gears, adapted to operate the whirl continuously in one direction at a varying speed; also, in a looper and a whirl and a hooked needle, in combination with mechanism, substantially as described, to impart to the needle a vertical and horizontal movement; also, in the combination, with the fulcrum-post of the needle-lever, and the cam to move such lever, of a locking device to hold the fulcrum-post so that the needle may have imparted to it a slight downward movement, to disengage the loop from its hook, substantially as described.

The invention is an improvement on the machine represented in United States Patents Nos. 36,163 and 45,422, to which reference may be had.

Figure 1 represents, in side elevation, a machine provided with the improvements herein described; Fig. 2, a front elevation thereof; Fig. 3, a detail, showing the locking device to hold the needle-fulcrum; and Figs. 4, 5, 6, 7, and 8, details, to be hereinafter referred to.

The horn in the drawing is shortened, so as to show on a single sheet the connection between the whirl and main shaft. In a working machine the horn will be shaped and operated as in the usual McKay machine.

The main shaft *a* of the machine will be provided, as in such machines, with cams to operate the presser-foot, lifting-lever, the needle-bar actuating-lever, and cast-off bar, (they being mounted upon a movable fulcrum-post,) and with a cam to move the rocking-shaft, connected with and so as to operate the feeding device, and to move the pawls to lock and unlock the ratchet, to permit the presser to be lifted as the needle rises. This shaft is also provided with an eccentric-gear, *b*, adapted to engage a second eccentric-gear, *c*, on a shaft, *d*, having a bevel-pinion, *e*, which engages a

bevel-pinion, *f*, on a vertical shaft, *g*. This shaft *g* is connected, through other bevel-gears and shafts, with the pinion *h* at the axis of the horn, it in turn rotating the whirl *i* through the usual shafts and bevel-gears. These eccentric-gears move the whirl continuously in one direction, but at a varying speed.

When the needle is below the stock, the whirl is rotated rapidly; but when the needle is raised, the whirl is moved slowly.

By avoiding the stoppage of the whirl, it is possible to move it with more accuracy and with less shock than if the whirl had periods of rotation and rest as it was moved in one direction, as described in another application made by me for Letters Patent under date of December 6, 1876.

In the present machine two threads are employed in the formation of the stitch. One of them is supplied to the hooked needle *k* by the usual whirl, and the other by a looper, *l*, on a rock-shaft mounted in a bearing, *m*, connected and adapted to rise and fall with the presser-foot *n*, whose carrying-bar is constructed and operated as in the Patent No. 45,422.

The needle and cast-off bars *o p*, instead of being moved in fixed guides, are placed in guides in a frame, *q*, pivoted at *r*, and provided with an arm, *s*, slotted as at *t*, Fig. 5, to receive a pin, *u*, at the lower end of an arm, *v*, attached to an arm, *w*, which projects from a rock-shaft having a second arm, *x*, operated by the cam *y*. This rock-shaft and cam, and the connections between the arm *v* and the feed *15*, are as in the McKay machine.

The slot *t*, at the end of the arm *s*, permits the guide for the needle and cast-off bars to remain at rest when the feed-point is being engaged with the stock; and the screw *2* adjusts the parts so that the guide and needle and feed move forward together.

A spring, *3*, (shown in Fig. 2,) moves the frame *q* back into vertical position.

The looper *l* has upon its shaft a spiral spring, *4*, to permit the looper and its shaft to move longitudinally in case it strikes the needle or is struck by it.

An arm, *6*, on the looper-shaft has a pin, *7*, to enter a slot in an arm, *8*, of a slide-bar, *9*, fitted in ways in the plate *10*.

The slide-bar *9* is reciprocated by means of

an arm, 11, on a vertical shaft, 12, having a second arm, 13, provided with a roller to enter a groove in a cam, 14, on the main shaft, such cam rocking the shaft 12, and, through its connections, moving the looper at the proper times.

The fulcrum-post 16 of the needle-lever 17 is allowed to rise and fall, as in the patents referred to; but, unlike such patented machine, the fulcrum-post is locked for a short space of time, as hereinafter described, so as to cause the needle to descend a little before it completes its ascent.

The locking device to hold the fulcrum-post at rest is composed, in this instance, of a griper, 18, fitted in ways in the plate 10, the griper being moved in one direction by a lever, 20 and cam 21, and in the opposite direction by a spring, 22. (See Fig. 3.) The end of the griper is provided with V-shaped prongs, to enter correspondingly-shaped notches in the needle fulcrum-post. The needle fulcrum-post is provided with an arm, 23, which rests at the proper times upon the slide 24 of the lever 25, connected at its back end with the collar 26, attached to the post 27 of the presser-foot lifting-lever 28.

The forward end of lever 25 rests upon the presser-bar, and these parts operate as in the patented machine before cited.

The lowermost position of the presser-foot is determined by the adjusting-nut 19.

In Fig. 2 the hooked needle is shown as driven down through the stock, and in such position the whirl is operated at its fastest speed, to present its thread to the hook of the needle. The looper, provided with two eyes for the passage of the thread, supplied from a suitable spool, and grooved at its rear side, (see detail, Fig. 6,) to permit the entrance of the hooked needle between the looper and its thread, then rests in its extreme backward position.

As the needle commences to rise, the pawls engage the ratchet, and the presser-lifting lever raises the presser-foot gradually, to release the stock from pressure. When the hooked needle rises sufficiently far to draw the loop of thread from the whirl completely up through the stock, then the feed 15, which by this time has engaged the stock, is moved laterally to feed the stock for a new stitch.

During the time that the feed takes place, the needle and cast-off are also moved to the left, and the looper is turned toward the needle. This movement of the needle and looper permits the loop of thread drawn up and held by the hooked needle to be passed over the looper and its thread, as shown in detail, Fig. 7. Just as the loop of needle-thread is placed in proper position upon the looper, the griper is caused to grasp and hold the fulcrum-

post 16 of the needle-bar, while the grooved cam operates the needle-lever, to give a slight downward motion to the needle, sufficient to disengage the loop drawn up by it from the needle-hook. After this the fulcrum-post is released, the needle completes its ascent, leaving its loop on the looper, and is then moved to the right, again regaining its position in the line of the opening in the horn and whirl. During the time that the needle completes its ascent free from the thread and moves to the right the looper remains with its point in its position nearest the presser-foot; and as the hooked needle descends it enters the loop of looper-thread, (see Fig. 8,) extended across the rear side of the looper, between its point and heel, (the loop of thread just drawn up by the hooked needle yet remaining over the looper-thread and looper at its heel,) and, passing through such loop of looper-thread, the needle again penetrates the stock, when the looper is withdrawn or turned back to the position shown in Fig. 2, leaving the loop of needle-thread just held by it extended about the loop of looper-thread lying on the surface of the stock or in the usual channel therein. The needle, in its next ascent, as it draws up a new loop of thread from the whirl, draws the previously-formed bight of whirl-thread closely down upon the loop of a looper-thread, and close to the stock.

The stitch formed is substantially that known as the "Grover and Baker."

The pawls 32 are, in this instance, released from the ratchet by means of a finger, 35, on a slide-bar, 36, it having a lug, 37, which is struck by the upper ends of the lever *v*.

I claim—

1. The combination, with the horn and the whirl and the hooked needle, of the eccentric-gears and connecting mechanism, substantially as specified, whereby the whirl is caused to revolve continuously in one direction at a varying speed, substantially as described.

2. The thread-carrying looper and thread-carrying whirl, in combination with the hooked needle, and mechanism, substantially as described, to impart to the needle vertical and horizontal movements, for the purpose set forth.

3. The needle fulcrum-post, in combination with the griper, and mechanism to operate it, to lock the fulcrum-post just before the needle completes its ascent, substantially as described.

In testimony whereof I have signed my name to this specification in the presence of two subscribing witnesses.

LYMAN R. BLAKE.

Witnesses:

G. W. GREGORY,
W. J. PRATT.