



US 20070127855A1

(19) **United States**

(12) **Patent Application Publication**
Smith et al.

(10) **Pub. No.: US 2007/0127855 A1**

(43) **Pub. Date: Jun. 7, 2007**

(54) **DOUBLE WALL BAGS**

(30) **Foreign Application Priority Data**

Jun. 26, 2003 (GB)..... 0314885.5

(75) Inventors: **Ian John Smith**, Prescott (GB); **John Joseph Dermot Griffiths**, Burnley (GB); **Patrick Thomas Connelly**, Newton (GB); **Paul Stuart Brassington**, Burnley (GB)

Publication Classification

(51) **Int. Cl.**
B65D 30/08 (2006.01)
B65D 33/16 (2006.01)
(52) **U.S. Cl.** **383/111; 383/66**

Correspondence Address:
TROUTMAN SANDERS LLP
600 PEACHTREE STREET, NE
ATLANTA, GA 30308 (US)

(57) **ABSTRACT**

The invention relates to plastic bags and sack for use especially in the food and pharmaceutical industries. The bag (2) comprises inner and outer bag sections (4, 14) which are joined at least at an upper portion in a manner which allows them to be separated when required, such as by heat sealing. The outer bag section (14) may be provided with a mouth (10) through which the inner bag section can be withdrawn when required. Alternatively, the outer bag section may be peeled away from the inner bag section. The inner bag section is heat sealed after filling with contents to retain the contents in the inner portion. The heat sealing step also serves to secure the bag sections together as above. The inner bag section is preferably provided with a closeable mouth (132) separate from the end by which it is filled, through which the contents may be dispensed.

(73) Assignee: **Flexipol Packaging Ltd.**, Rossendale (GB)

(21) Appl. No.: **10/561,932**

(22) PCT Filed: **Jun. 28, 2004**

(86) PCT No.: **PCT/GB04/02780**

§ 371(c)(1),
(2), (4) Date: **May 5, 2006**

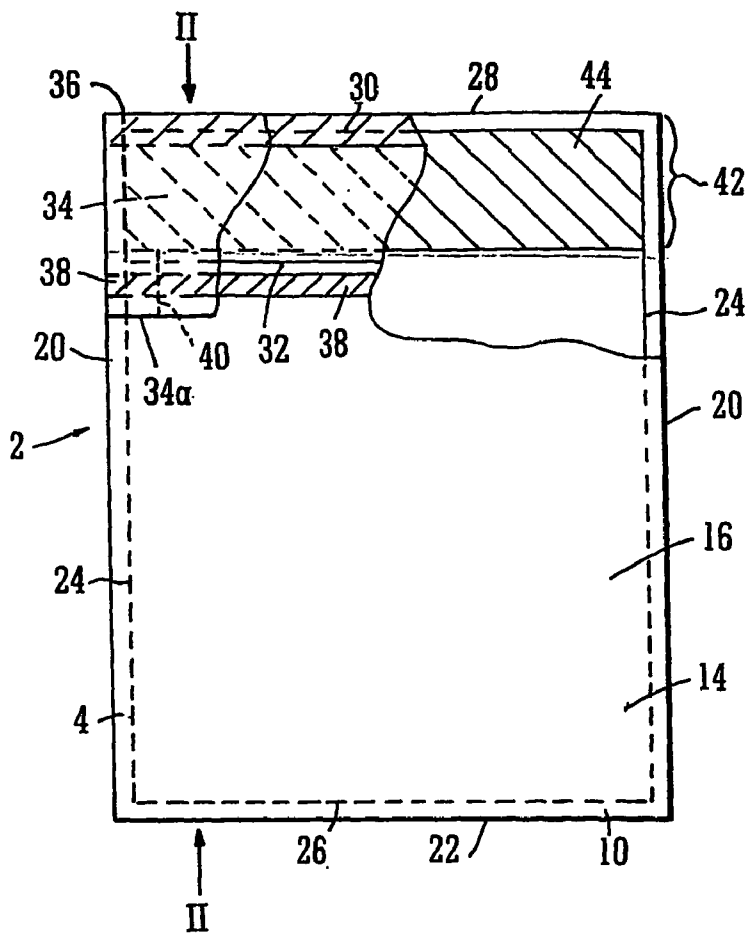

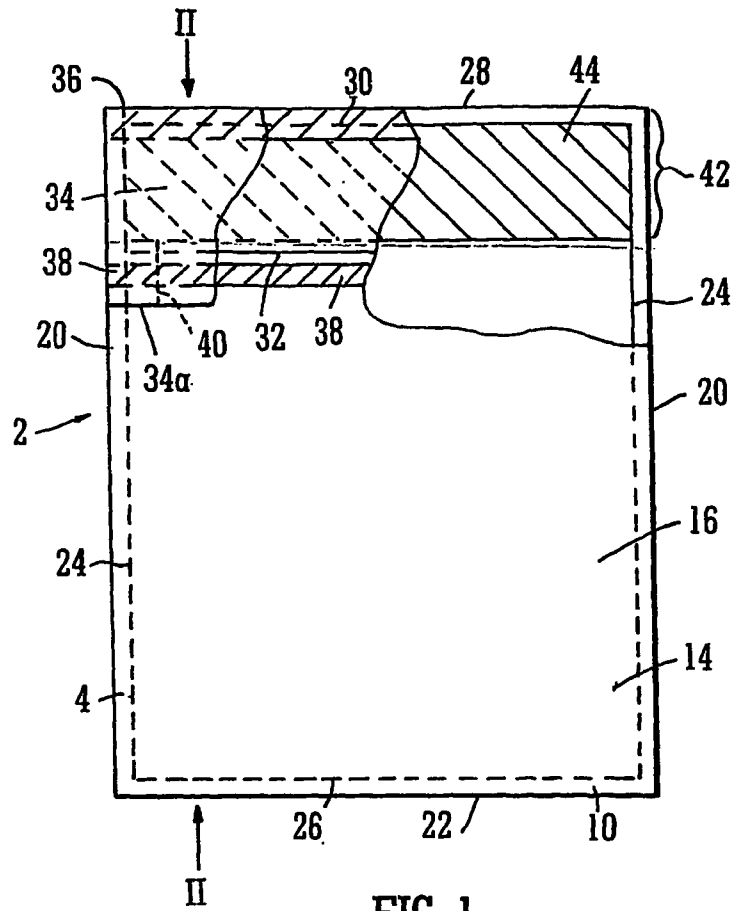

FIG. 1

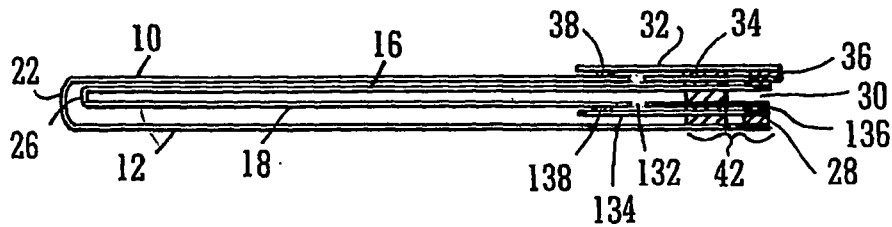

FIG. 2A

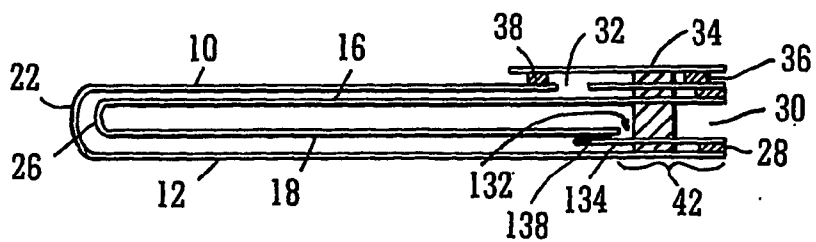

FIG. 2B

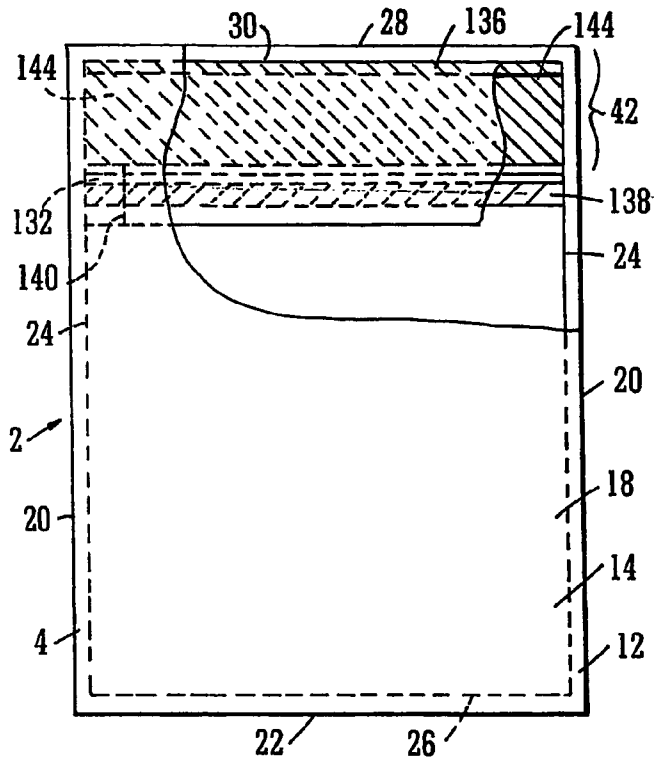

FIG. 3

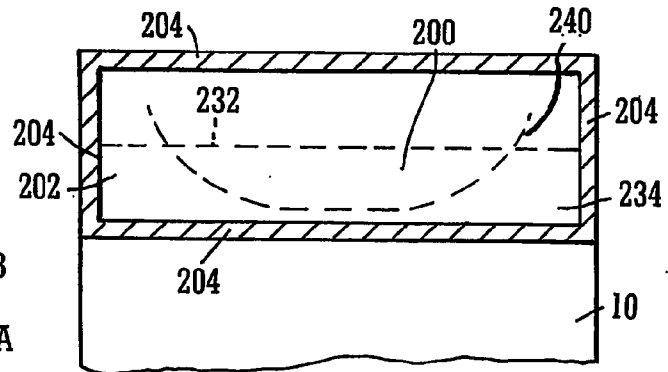

FIG. 4

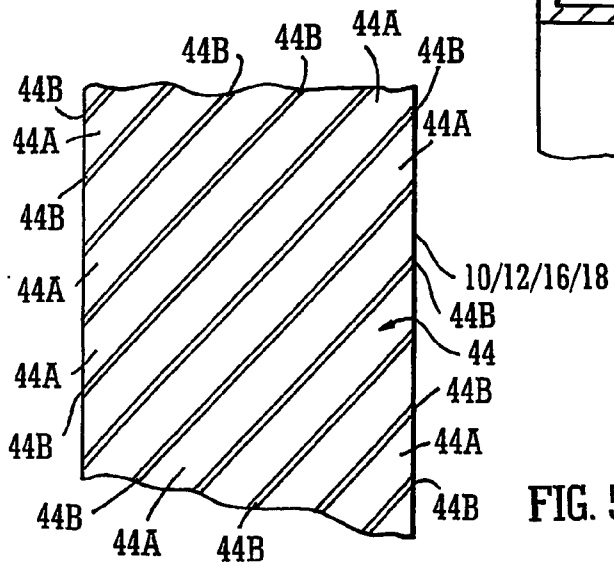

FIG. 5

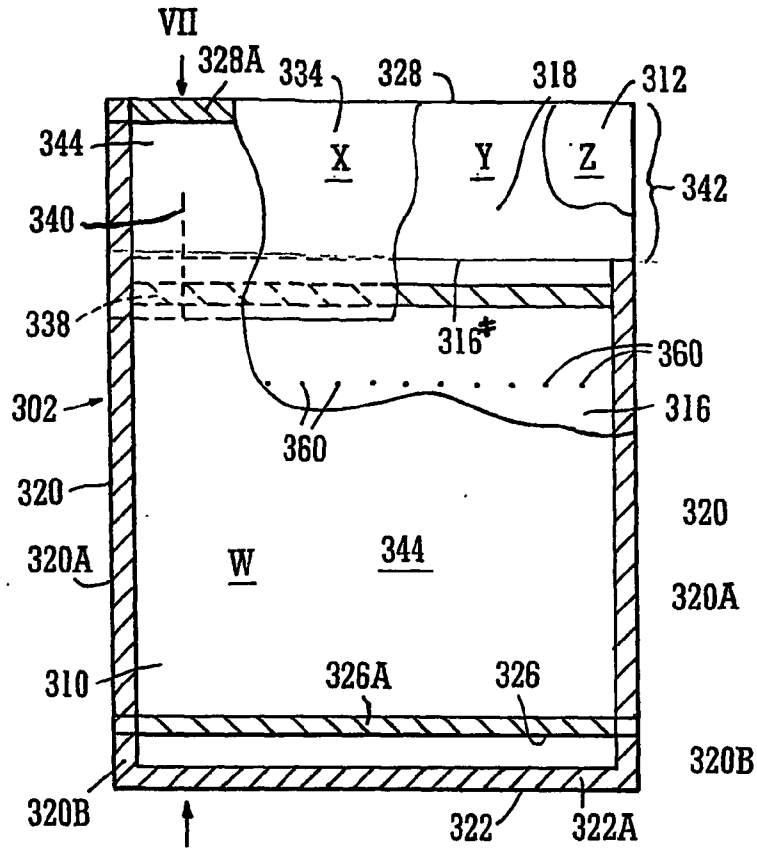

FIG. 6

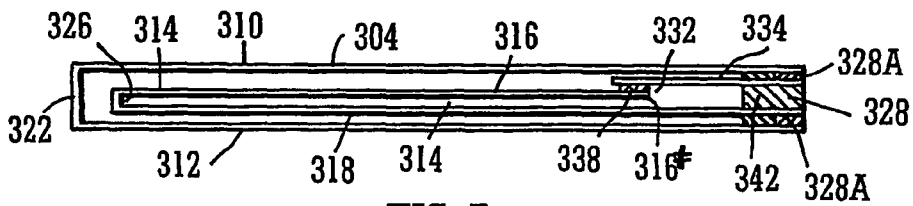

FIG. 7

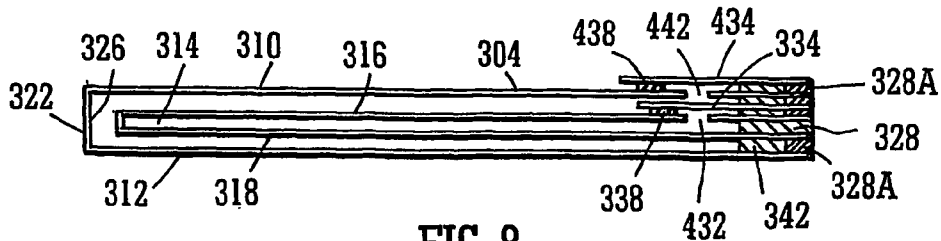

FIG. 8

DOUBLE WALL BAGS

[0001] The present invention relates to bags and sacks and in particular to plastic bags and sacks for use in the food and pharmaceutical industries, especially for the storage and transport of powdery or granular materials, other flowable solid materials or the like.

[0002] The food and pharmaceutical industries necessarily place stringent requirements on the handling of ingredients and components, as well as on final products sold to commercial users and consumers. These requirements are essential to prevent contamination with dust, dirt or other foreign bodies, or with, for example, bacteria. Conventional bags and sacks have tended to use at least one layer, usually an outer layer, of a paper-based material which is closed by stitching. This sort of construction has the significant disadvantage that, on opening of the bag, pieces of paper or stitching thread may contact and become mixed with the contents of the bag. Other bags are made of plastics material and suffer a similar problem in that the closure of the bag often requires the bag to be cut open to access the contents. This carries the danger that shards of plastic from the cutting step can contact the bag contents.

[0003] The present invention seeks to overcome these problems by providing a plastic bag or sack with an easy open closure which does not require any cutting and which does not generate any loose pieces or shards of plastic or other material on opening. The present invention further seeks to provide a plastic bag or sack wherein the portion of the bag containing product is maintained in a clean, hygienic environment—for example during transport and storage—until the bag is to be opened. More specifically, the present invention provides a bag comprising an inner bag portion and an outer cover portion, both portions being closeable after the inner portion is filled with contents and the inner bag portion being removable or separable from the outer portion without disrupting the closure of the inner bag portion.

[0004] According to a first aspect of the present invention there is provided a plastic bag comprising:

[0005] i) a cover section comprising first and second opposed walls;

[0006] ii) a bag section comprising third and fourth opposed walls joined at their side and base edges and an open end by means of which the bag section may be filled with contents, the first and second walls being arranged to enclose the bag section;

[0007] iii) a closeable mouth defined in a wall of the bag section for access in use to the interior of the bag section;

[0008] iv) a closeable region, distinct from the mouth, including an end portion of the cover section and an end portion of the bag section proximate the open end of the bag section, within which closeable region the bag section may be sealed closed after filling;

[0009] wherein, in the closeable region, an internal face of at least one of the respective first and second walls is attached and/or attachable to an adjacent external face of a wall of the bag section, the attachment being such that the bag section is separable in use from the cover section without compromising the seal of the bag section in the closeable region.

able in use from the cover section without compromising the seal of the bag section in the closeable region.

[0010] Preferably the open end of the bag section may operatively be sealed after filling by heat sealing the bag section walls together in the closeable region.

[0011] In a preferred embodiment of the invention, for attachment of the cover section to the bag section in said closeable region, an internal face of at least one of the respective first and second walls of the cover section is attachable to at least one external face of a bag section wall by heat sealing in the closeable region. Preferably this heat sealing is effected in the same operation by which the bag section walls are sealed together in the closeable region.

[0012] Preferably at least one member selected from the group comprising the internal faces of the first and second walls and the respective external faces of the bag section walls comprises a first treated area in the closeable region, said first treated area being effective to limit the strength of the heat seal between the cover section and bag section. Thus at least one of the walls of the cover section and/or of the bag section includes such a first treated area, whereby the resulting strength of the heat seal is insufficient to prevent intentional separation of the bag section from the cover section by a user. The heat seal is, nevertheless strong enough to maintain the union between the cover section and the bag section in the closeable region until separation of the respective sections is desired.

[0013] In a particularly preferred embodiment said first treated area comprises coated or printed areas, zones or regions (hereinafter “printed areas”), the printed areas being resistant to heat sealing. Thus little or no heat seal is formed within the printed areas, but a heat seal is formed outside the printed areas, the result being a weaker heat seal across the treated area taken as a whole.

[0014] In a preferred variation of the bag of the invention the first and second walls are also separably attached respectively to the bag section walls in areas other than said closeable region. Preferably in this variation the first and second walls are substantially co-extensive with the width of the bag section walls. The width of the cover section walls should not be less than that of the bag section walls, but may be more. Most preferably, the first and second walls are separably attached to the bag section walls in areas proximate the side edges of the bag section.

[0015] Preferably in this variation the first and second walls are removeably heat sealed respectively to the bag section walls in said separably attached areas.

[0016] More preferably in this variation at least one of the first wall and the adjacent bag section wall and/or at least one of the second wall and the adjacent bag section wall comprises a second treated area, said second treated area being effective to limit the strength of the heat seal between respectively the first and third and the second and fourth walls in said separably attached areas. Preferably said second treated area comprises printed areas, the printed areas being resistant to heat sealing.

[0017] The first and/or second treated areas may comprise, in a said treated area, alternate printed and non printed areas. The relative areas of the printed and non printed areas can

be determined by one skilled in the art by simple experiment in order to achieve a union between the walls of appropriate strength, allowing the walls to be separated when desired. This may depend, for example, on the materials from which the walls are made and the characteristics of the particular heat sealing apparatus which is used. Preferably, however, the area of the printed areas is greater than the area of the non-printed areas.

[0018] In a particularly preferred arrangement, the printed and non-printed areas alternate to define stripes across the closeable region and/or across the separably attached areas. In preferred examples, typically the non-printed areas have a width of not more than about 2 mm, preferably about 0.5 mm to 1.5 mm and typically the printed areas have a width of not more than about 10 mm, preferably about 3 mm to about 8 mm, more especially about 5 mm.

[0019] In a particularly preferred form of the invention, the whole surface of a wall comprises with a treated area. For example the whole inner surface of the first and/or may comprise a treated area. Likewise, the whole external surface of the third and/or fourth walls may comprise a treated area. The external surface of the first and second closure flaps (where present) may also comprise a treated area. In the most preferred arrangement, the whole of the inner surface of the first and second walls comprises a treated area, the surfaces of the third and fourth walls not being coated or printed and, where present the surfaces of the closure flap(s) not being treated. It is especially preferred that the whole inner surfaces of the first and second walls are printed or otherwise coated with alternating printed and non printed areas in a pattern of stripes as described in the preceding paragraph.

[0020] In an alternative (or additional) arrangement, the treated area may comprise an embossed area of one or more of the walls.

[0021] In another preferred form of the invention the cover section is longer than the bag section such that the cover section extends beyond the base (lower) end of the bag section, the first and second walls being joined to each other in said lengthwise extending portion. For example, in the lengthwise extending portion, the first and second walls may be joined to one another by a permanent or separable heat seal at the edges of said walls.

[0022] In one alternative preferred arrangement the width of the cover section is greater than the width of the bag section such that the cover section extends beyond the side edges of the bag section, the first and second walls being joined to each other in said widthwise extending portion. For example, in the widthwise extending portion, the first and second walls may be joined to one another by a permanent or separable heat seal at the edges of said walls. Preferably, but not essentially, in this arrangement the first and second walls are not attached respectively to the bag section walls in areas other than said closeable region.

[0023] In a particularly preferred embodiment the plastic bag of the invention further comprises:

[0024] a first closure flap overlying and closing said mouth defined in a wall of said bag section, said first closure flap including a first attached region which is peelably attached to said bag section wall such that at least a portion of said first closure flap may be peeled

away from said bag section wall across the peelably attached region to reveal the mouth, and, optionally, a second attached region spaced from the peelably attached region in which second region said first closure flap is also attached to said bag section wall.

[0025] In an alternative, but functionally substantially equivalent, embodiment the plastic bag of the invention further comprises:

[0026] a first closure flap overlying and closing said mouth defined in a wall of said bag section and including a first region which is attached to a said bag section wall, said first closure flap including at least one line of weakness defining a tearable portion of said first closure flap within which tearable portion said first closure flap is not attached to the bag section wall and which tearable portion can be opened by tearing along the line of weakness to reveal the mouth; and, optionally, a second attached region spaced from the tearable portion in which second region said first closure flap is also attached to said bag section wall.

[0027] Preferably in these embodiments the first closure flap extends into the closeable region. In this case a first treated area may be formed on the first closure flap instead of a treated area of the bag section. That is, a first treated area on an external face of a bag section wall is then no longer required and is provided instead on the first closure flap. In one variation, the wall of the bag section to which the closure flap is attached may be made shorter than the other wall of the bag section, the closure flap then acting as an extension of the bag section wall to which it is attached.

[0028] In another embodiment of the invention one or both of the respective first and second walls of the cover section is/are adhered to the bag section proximate the open end of the bag section. This may be in addition to the heat sealing in the closeable region as defined above. Preferably in this case the cover section is adhered to the bag section at marginal portions of the closeable region.

[0029] In another embodiment of the invention, the plastic bag further comprises a second closeable mouth defined in the first or second wall of the cover section for access in use to the bag section. This embodiment is applicable both to the case where the cover section extends widthwise beyond the bag section (more especially where the edges of the first and second walls in the widthwise extending portion are permanently joined together, so that the bag section can then be withdrawn from the cover section through the second closeable mouth) and to the case where the cover section and the bag section have nominally the same width.

[0030] In a preferred variation of this embodiment, the plastic bag further comprises:

[0031] a second closure flap including a first attached region which is peelably attached to said cover section wall such that at least a portion of the closure flap may be peeled away from said cover section wall across the peelably attached region and a second attached region spaced from the peelably attached region in which second region the second closure flap is also attached to said cover section wall.

[0032] In an alternative, but substantially functionally equivalent variation, the plastic bag further comprises:

[0033] a second closure flap including a first region which is attached to said cover section wall, the second closure flap including at least one line of weakness defining a tearable portion of the closure flap within which tearable portion the closure flap is not attached to said cover section wall and which tearable portion can be opened by tearing along the line of weakness and a second attached region spaced from the tearable portion in which second region the second closure flap is also attached to said cover section wall.

[0034] Where the plastic bag further comprises a second closeable mouth defined in the first or second wall of the cover section for access in use to the bag section, the second closure flap (in either of the above alternative constructions) is arranged to cover the mouth so that when the second closure flap is peeled or torn back, the mouth is revealed.

[0035] As an alternative to, or in addition to, the second closure flap the plastic bag may preferably comprise gripping means formed in or on, or attached to the first or second walls, to facilitate gripping of said walls on separation of the cover section from the bag section.

[0036] According to a second aspect of the invention there is provided a method of handling a flowable product comprising:

[0037] i) providing a bag according to the first aspect of the invention;

[0038] ii) filling the bag section with the flowable product through the open end of the bag; and

[0039] iii) applying heat sealing means to the closeable region thereby to heat seal the bag section walls together to sealingly close the bag section and to heat seal the first and/or second walls to the bag section walls to separably attach the cover section and bag section together.

[0040] Preferably the method further comprises:

[0041] iv) separating the cover section from the bag section in the closeable region;

[0042] v) if necessary, separating the cover section from the bag section outside the closeable region and

[0043] vi) withdrawing the bag section from the cover section.

[0044] According to a third aspect of the invention there is provided a plastic bag comprising:

[0045] i) a cover section comprising first and second opposed walls;

[0046] ii) a product containing bag section comprising third and fourth opposed walls joined at their side and base edges, the first and second walls being arranged to enclose the bag section;

[0047] iii) a closeable mouth defined in a wall of the bag section for access in use to the interior of the bag section;

[0048] iv) a sealing region, distinct from the mouth, including an end portion of the cover section and an end

portion of the bag section within which sealing region the bag section is sealed closed after filling bag section with product;

[0049] wherein, in the sealing region, an internal face of at least one of the respective first and second walls is attached to an adjacent external face of a wall of the bag section, the attachment being such that the bag section is separable in use from the cover section without compromising the seal of the bag section in the sealing region.

[0050] Preferably, within the sealing region, the respective first and second walls of the cover section are attached to at least one of the external faces of the respective bag section walls of the bag section by means of a heat seal formed contemporaneously with the heat seal which seals the bag section walls.

[0051] Preferably at least one of the internal faces of the first and second walls and the external faces of the bag section walls comprises a treated area in the sealing region, the treated area being effective to limit the strength of the heat seal between the cover section and bag section.

[0052] In a preferred embodiment of this aspect of the invention, the plastic bag further comprises:

[0053] a first closure flap overlying and closing said mouth defined in a wall of said bag section, said first closure flap including a first attached region which is peelably attached to said bag section wall such that at least a portion of said first closure flap may be peeled away from said bag section wall across the peelably attached region to reveal the mouth, and, optionally, a second attached region spaced from the peelably attached region in which second region said first closure flap is also attached to said bag section wall.

[0054] In an alternative, but functionally substantially equivalent embodiment of this aspect of the invention, the plastic bag comprises

[0055] a first closure flap overlying and closing said mouth defined in a wall of said bag section said first closure flap including a first region which is attached to a said bag section wall, said first closure flap including at least one line of weakness defining a tearable portion of said first closure flap within which tearable portion said first closure flap is not attached to the bag section wall and which tearable portion can be opened by tearing along the line of weakness to reveal the mouth; and, optionally, a second attached region spaced from the tearable portion in which second region said first closure flap is also attached to said bag section wall.

[0056] In a preferred variation the first closure flap extends into the closeable region. Preferably in this variation a first treated area is formed on the first closure flap instead of a treated area of the bag section. More preferably, a treated area is provided across the whole of one or both of the first and second walls and, preferably, no treated area is provided on the bag section.

[0057] For a better understanding of the invention and to show how the same may be carried into effect reference will be made, by way of example only, to the following drawings, in which:

[0058] FIG. 1 is a partially cut away plan view of a bag according to one embodiment of the invention;

[0059] FIG. 2A is a cross-section along the line II-II of FIG. 1;

[0060] FIG. 2B is similar to FIG. 2A showing a variation in the construction of a closure flap;

[0061] FIG. 3 is a partially cut away plan view of the bag of FIG. 1 from the reverse side;

[0062] FIG. 4 is a simplified plan view of an alternative construction of a closure flap of the bag of the invention;

[0063] FIG. 5 is a representation of treated and non-treated areas on a cover section or bag section wall of the invention;

[0064] FIG. 6 is a partially cut away plan view of a bag according to a second embodiment of the invention;

[0065] FIG. 7 is a cross-section along line VII-VII of FIG. 6; and

[0066] FIG. 8 is similar to FIG. 7, showing a further closure flap on the exterior of the bag.

[0067] Referring now to the FIGS. 1 to 4, the bag 2 of the this embodiment comprises a cover section 4 defined by first and second opposed walls 10, 12 and a bag section 14 defined by third and fourth opposed walls 16, 18. The bag section 14 is smaller than the cover section 4 and lies within the cover section 4. The cover section 4 is closed on opposed side edges 20 and lower (base) end edge 22 by suitable means for joining the first and second walls together, such as adhesive or, more preferably, heat welding or heat sealing. The opposed side edges 20 may be joined together in a permanent or (preferably) separable manner. The bag section 14 is closed on opposed side edges 24 and lower (base) end edge 26 by suitable means for joining the third and fourth walls together. Alternatively, the respective first and second walls and third and fourth walls may be formed integrally, as a flattened tube. At end 28 the first and second walls 10, 12 are not joined to each other. The third and fourth walls 16, 18 define an open end of the bag 30, the walls 16, 18 also not being joined to each other at this end. In FIGS. 1 to 3, the ends 28, 30 are shown slightly displaced from one another, for clarity of illustration. Preferably, however, the ends 28, 30 lie essentially along the same notional line.

[0068] First wall 10 includes a mouth 32 which preferably takes the form of a slit formed in the first wall 10. The mouth 32 may initially be in the form of a line of weakness, such as a line of perforations, which is breached when required to form the mouth 32. Most preferably, a closure flap 34 is provided on the first wall 10. The closure flap 34 extends across substantially the whole width of first wall 10 and so lies over, and closes, the mouth 32. The closure flap 34 is affixed to the first wall 10 in region 36 preferably by a suitable adhesive. The adhesive may be permanent so that the closure flap 34 and the first wall are not separable in region 36. The closure flap 34 is also attached to the first wall 10 in region 38. Region 38 is such that the closure flap 34 may be peeled away from the first wall 10 across the region 38 without substantially or significantly damaging the first wall 10. More especially, it is important that the bond in the region 38 (whether adhesive or otherwise) between the closure flap 34 and the first wall 10 is such that the first wall 10 and the closure flap 34 can be separated from

one another without generating shards or pieces of plastic which may subsequently contaminate, or have the potential to contaminate, the contents of the bag section 4. Region 38 may be a welded or heat sealed region but is most preferably at least one region of peelable adhesive. It is most preferable that the region 38 extends from one side edge 20 to the other side edge 20 without interruption. In the illustrated embodiment, region 38 comprises a single line of peelable adhesive. In alternative constructions, a plurality, especially two or three, lines of peelable adhesive may be provided. A corresponding region of peelable adhesive (not illustrated) may be provided on the opposite side of the mouth 32 from region 38. A line of weakness 40 is provided at one side of the closure flap 34 and a corresponding line of weakness (not illustrated) is provided at the other side of the closure flap. For access to the mouth 32, the closure flap 34 is torn along the lines of weakness 40 and peeled back through the region 38 to reveal the mouth 32. Numerous alternative constructions for the lines of weakness 40 are possible. For example, the lines of weakness could be curved or at an angle with respect to the side edges 20, or a single line of weakness 40 in the form of an arc extending from the leading edge 34a of the closure flap 34 above the region 38 and the mouth 32 and returning to the leading edge 34a at the other side of the closure flap 34.

[0069] Where the first and second walls are separably (rather than permanently) attached to one another, or separably attached to the bag section, the closure flap may be omitted and, if the closure flaps 34 is present, the mouth 32 may be omitted. In preferred variations, both the closure flap 34 and mouth 32 are present.

[0070] In some preferred constructions of the bags according to this embodiment of the invention, the bag section 14 is initially attached (e.g. adhered) to the cover section 4 with an adhesion sufficient to maintain the desired relative positions of the sections 4, 14 prior to the heat sealing step described below by which the bag section is joined to the cover section in the closeable region. This adhesion, if present, must be sufficient to maintain the relative positions of the bag section 14 and cover section 4, but not sufficient to prevent easy separation of the sections 4, 14 when required. Thus, for example, an external face of the third wall 16 may be provided with a line of adhesive adjacent the open end 30 by means of which the third wall is adhered to an internal face of the first wall 10. Similarly, an external face of the fourth wall 18 may be provided with a line of adhesive adjacent the open end 30 by means of which the fourth wall 18 is adhered to an internal face of the second wall 12.

[0071] The bags of this embodiment of the invention are provided with a closeable region 42 which can extend from above the mouth 32 towards the ends 28, 30 of the cover section and bag section 4, 14. The actual extent of the closeable region 42 can be determined in accordance with the manufacturer's wishes but it is essential in this embodiment that the closeable region 42 does not encompass the mouth 32. Within the closeable region, heat sealing means can be applied to the bag whereby the internal faces of the third and fourth walls 16, 18 are heat sealed together. In this way the bag section 14 is sealed and closed after having been filled with contents. This heat sealing step may also seal together any portions of the first and second walls 10, 12 which extend beyond the upper edge of the bag section 14.

[0072] The heat sealing step for sealing together the third and fourth walls **16, 18** is also effective in securely attaching the cover section **4** to the bag section **14**. This is achieved in accordance with the invention in such a way that the sections **4, 14** are sufficiently securely attached to prevent them from being separated in normal transport and handling but not so securely that the sections **4, 14** cannot be separated manually when desired.

[0073] It would normally be expected that simple application of a heat seal which joins the first wall **10** to the third wall **16** and the second wall **12** to the fourth wall **18** will result in a joint between the respective walls of a strength such that the cover portion **4** is not easily separable when required from the bag section **14**. In this respect, the choice of materials for the first, second, third and fourth walls **10, 12, 16, 18** can affect the strength of the heat seal and it is possible, for example, to achieve a heat seal of the desired strength by selecting materials respectively for the first and third and for the second and fourth walls whose compatibility for heat sealing is poor. In this way, the strength of the resultant heat seal is not too great and so the cover section **4** can be separated from the bag section **14** when required. The choice of materials in this respect is within the skill and knowledge of the person skilled in the art.

[0074] However, in preferred embodiments of the invention, at least one of the first, second, third and fourth walls, **10, 12, 16, 18** is provided, at least in the closeable region, with a treated area **44** which interferes with the heat seal so limiting or reducing its strength to an extent that the first and bag sections **4, 14** can be separated when required. The treated area **44** is preferably provided on an internal surface of both the first and second walls **10, 12** or on an external surface facing the internal surface of the walls **10, 12**, such as both external surfaces of the third and fourth walls **16, 18**.

[0075] The treated area **44** can take any reasonable form for appropriately weakening the heat seal in the closeable region (that is, the heat seal other than that between the internal surfaces of the third and fourth walls) provided that other features of the bag are not adversely affected. For example, the first and second walls **10, 12** or the third and fourth walls **16, 18** may be provided with an embossed region which interferes with the heat seal.

[0076] In a particularly preferred form of the invention the treated area extends over the whole of the internal surfaces of the first and second walls **10, 12**. Of course, the effect of the treated area is apparent only in those areas which are subsequently heat sealed.

[0077] Most preferably, however, the treated area **44** is a coated or printed area. The treated area **44** is preferably not printed across the whole area. Rather, the treated area preferably comprises printed regions **44A** and non-printed regions **44B** (FIG. 5). The relative areas of the printed and non-printed regions will determine the strength of the resultant heat seal, that is, in general terms, the greater the area of the printed regions, the weaker will be the heat seal. Preferably, the treated area comprises alternate printed and non-printed regions, for example in the form of alternating stripes which may be arranged, for example, diagonally with respect to side edges **20**. The relative areas of the printed and non-printed regions in any given bag of the invention can be determined by simple experiment by the person of ordinary skill in the art, in order to achieve an effective bond strength

of the heat seal. Typically, relatively wide printed regions will alternate in the treated area **44** with relatively narrow non-printed regions.

[0078] In use of the bags according to the invention, the bag section **14** is first filled with the product to be contained in the bag **2** through the open end **30**. When the desired amount of product has been placed in the bag section **14**, the bag is closed by heat sealing in the closeable region **42**. That is, the heat sealing in the closeable region **42** seals together the third and fourth walls **16, 18** whereby the product is sealed within, and prevented from escaping from, the bag section **14**. In the same sealing step, the cover section and bag section **4, 14** are joined together with a heat seal, in the closeable region **42**, between the internal surfaces of the first and second walls **10, 12** and external surfaces of the bag section **14**. It is noted that this heat sealing may be in addition to an initial adhesion of the cover section **4** and bag section **14** sufficient to retain the sections together before and during filling. The heat sealing in the closeable region **42** may, for example, form a joint between the first and third walls **10, 16** and the second and fourth walls **12, 16**. After the heat sealing step, the bag and its contents may be stored or transported as required. When access is required to the contents of the bag, the mouth **32** in the first wall **10** is opened. In accordance with the illustrated embodiment, the closure flap **34** is peeled back through the region **38** by tearing along the lines of weakness **40** to reveal the mouth **32**. The cover section **4** and bag section **14** are then separated by breaking apart the heat seal in the closeable region **42** (which includes a treated area **44**) between the sections **4, 14**. The bag section **14** may then be withdrawn through the mouth **32** of the cover section **4**. Alternatively, depending on the extent of the provision of the treated area(s) **44**, the first and second walls may simply be peeled away from the bag section **14**. At this stage, the heat seal between the third and fourth walls of the bag section remains intact so that the contents continue to be retained in the bag section **14**. The bag section **14** may then be opened as desired to access the contents.

[0079] In a much preferred embodiment the bag section **14** is also provided with a mouth **132** and a closure flap **134** overlying and closing the mouth **132**. The construction of the closure flap **134** is essentially the same as that of the closure flap **34**. Thus, the closure flap **134** is preferably permanently adhered to the bag section **14** in region **136** and is peelably adhered to the bag section **14** in region **138**. The closure flap **134** is also provided with lines of weakness **140**. Thus, after separation of the cover section **4** and the bag section **14**, such as by extraction of the bag section **14** from the cover section **4** through mouth **32**, the bag section **14** can be opened by tearing the closure flap **134** along the lines of weakness **140** and peeling back through the peelably attached region **138** to reveal the mouth **132**, through which the contents of the bag section **14** may be dispensed. As with the mouth **32**, the mouth **132** may initially be formed as a line of weakness such as a perforation which is breached to form the open mouth **132**.

[0080] The closure flap **134** and mouth **132** may preferably be disposed on the fourth wall of the bag section, that is so that the closure flap **134** and mouth **132** are arranged on the wall (**18**) of the bag section which is distant from the mouth **32** and closure flap **34**. In this construction, a treated area **144** may be formed on a region of the closure flap **134**

on its face juxtaposed with the second wall 12. Such a treated area 144 on the closure flap 134 is preferably in addition to the treated area 44 formed on the third wall 16 in juxtaposition to the first wall 10. However, a treated area on the closure flap 134 is not needed if the internal surface of the second wall 12 has a corresponding treated area 44.

[0081] As can be seen from FIG. 2A, the closeable region in one preferred construction of the bag according to this embodiment of the invention encompasses the third and fourth walls 16, 18, the first and second walls 10, 12 and the first and second closure flaps 34, 134.

[0082] FIGS. 2A, 2B and 3 illustrate the mouth 132 and closure flap 134 at the top portion of the bag, approximately adjacent the open end 30. This construction is preferred but not essential. The mouth 132 may be formed in any part of the third or fourth wall 16, 18 other than the closeable region, and the closure flap 134 is positioned accordingly on the third or fourth wall 16, 18 so that the mouth 132 is closed. In these constructions, the closure flap 134 may be placed entirely outside the closeable region 42.

[0083] In a preferred construction, as shown in FIG. 2B, the fourth wall 18 is made shorter than the third wall 16 so that the mouth 132 is defined by an upper end edge of the fourth wall 18. The closure flap is then peelably attached to the fourth wall 18 in region 138 only with the remainder of the closure flap 134 directly overlying the internal face of the third wall 16. In effect, the upper portion of the closure flap becomes an extension of the fourth wall 18. Permanently attached region 136 is omitted. In this construction the heat seal which closes the bag section to retain the contents therein is made between the third wall 16 and the closure flap 134, but not with any part of the fourth wall 18. References herein to forming a heat seal between the third and fourth walls 16, 18 should be construed accordingly to include this construction, unless the context specifically requires otherwise. Likewise in this construction there is no heat seal in the closeable region 42 between the second and fourth walls 12, 18. Since the closure flap 134 acts as an extension of the fourth wall 18, the union in the closeable region is between an inner face of the second wall 18 and an external face of the closure flap 134. Again, reference to a union (heat seal etc) between an inner face of the first or second wall and an external face of a bag section wall should be construed to include the option of a closure flap of the bag section acting as an extension of the relevant bag section wall.

[0084] A similar construction is possible with respect to the closure flap 34 and the first wall 10 in that the first wall 10 may be made shorter than the second wall 12 so that the closure flap 34 is adhered to the first wall 10 only in region 38 with the upper part of the closure flap 34 directly overlying the third wall 16. The upper part of the closure flap 34 then acts in effect as an extension of the first wall 10 and is heat sealed in use to the treated area 44 on the third wall 16, in the closeable region 42. References to portions of the first wall in the closeable region and/or the interaction of the first wall with the treated area should be construed accordingly.

[0085] FIG. 4 illustrates an alternative construction of the closure flap which may be applied to either of the closure flaps 34 and 134 (and to closure flaps 334 and 434 described below). This construction achieves the same result as the

construction illustrated in FIGS. 1 to 3 but does not require a peelable adhesive. In the construction of FIG. 4 the closure flap 234 includes a line of weakness 240 extending in a curved line on either side of the mouth 232. Other lines of weakness are possible such as "V" or "U" shapes. An area 200 is thus bounded by the line of weakness 240 and within this area the closure flap 234 is not adhered at all to the underlying wall (10, 12, 16 or 18). Outside the area 200, in area 202 the closure flap 234 is adhered, welded or otherwise bonded to the underlying wall to form a closure over the mouth 232. To this end, heat sealing or adhering of the closure flap 234 around its marginal edges is shown at 204 in FIG. 4. The relevant bag section 4, 14 may thus be opened by tearing the closure flap 234 along the line of weakness 240 to reveal the mouth 232.

[0086] Referring now to FIGS. 6 to 8, the bag of the second embodiment of the invention comprises a cover section 304 and a bag section 314. The cover section 304 and the bag section 314 are most preferably of substantially the same width, although in the illustrated embodiment, the cover section 304 is longer than the bag section 314. The cover section 304 comprises first and second walls 310, 312 and the bag section 314 comprises third and fourth walls 316, 318. The end 328 of the bag portion 314 is open (i.e. the third and fourth walls 316, 318 are not joined together) to allow the bag portion 314 to be filled. At the sides 320 and base 326 of the bag portion 314 the third and fourth walls 316, 318 are permanently joined together, preferably by means of heat welding, as indicated in regions 320A and 326A respectively. In regions 320A at the sides of the bag 302 the respective first and second walls 310, 312 are separably attached to the underlying bag portion 314. Similarly, at the upper end 328 of the bag 302, the first and second walls 310, 312 are separably attached to the underlying bag portion 314 in region 328A, extending across the whole width of the bag 302. In regions 320B and 322A the first and second walls 310, 312 are attached to one another, preferably separably. In region 326A the first and second walls 310, 312 may be, but need not be, separably attached to the bag portion 314. In these regions 320A, 320B, 322A, 328A the first and second walls 310, 312 are preferably attached by heat welds.

[0087] The bag portion 314 is shown in FIGS. 6 and 7 as comprising a third wall 316 which is shorter than fourth wall 318. The edge of the third wall 316 is indicated at 316‡. However, the third and fourth walls 316, 318 could be the same length, as indicated in FIG. 8.

[0088] In FIGS. 6 and 7, a closure flap 334 overlies the upper portion of the third wall 316 and is attached to the third wall 316 by means of a band or line or peelable adhesive 338. The closure flap 334 is in effect an extension of third wall 316 and is separably attached to first wall 310 in region 328A. The closure flap includes a line of weakness 340 (and a corresponding line of weakness at the opposite side, not shown) along which the closure flap 334 can be torn to expose the mouth 332 defined by upper edge 316‡ of third wall 316, whereby access is gained to the contents of the bag portion 314.

[0089] The bag 302 includes a closeable region 342 between end 328 and the mouth 332 (but not including the mouth 332). In closeable region 342, the third and fourth walls 316, 318 are, in use of the bag, sealed closed after

filling of the bag portion **314** with its desired contents. This is most preferably achieved by means of heat sealing. The closeable region **342** is functionally the same as closeable region **42** of the first embodiment of the invention.

[0090] For the avoidance of doubt, in FIG. **6**, area W shows the complete bag including the first wall **310**, in area X the first wall **310** is cut away revealing the closure flap **334**, in area Y the closure flap is cut away revealing the third wall **316** and the fourth wall **318** and in area Z the third wall is cut away revealing the second wall **312**.

[0091] As mentioned above, the first and second walls **310**, **312** of the cover portion **304** are separably attached to the bag portion **314**, so as to enclose the bag portion. In the most preferred variations of the invention, the separability is achieved by providing a treated area or treated areas **344** which interfere with the strength of the union (preferably a heat seal) between the respective first and second walls **310**, **312** and the third and fourth walls **316**, **318** or closure flap **334**. The treated areas **344** are most preferably provided in the same way as the treated areas **44** according to the first aspect of the invention. Thus the treated areas are preferably coated or printed areas. For example, printed regions may be provided on the third and fourth walls **316**, **318** and the closure flap **334** in areas corresponding to (but preferably of somewhat greater extent than) regions **320A** and **328A**, together with an area corresponding to the closeable region **342** and, optionally, areas corresponding to areas **320B** and **326A**. In other words, the treated areas **344** are provided in only those regions where the first and second walls **310**, **312** are attached to the third and fourth walls **316**, **318** and to the closure flap **334**.

[0092] It is, however, more expedient in terms of the manufacture of the bags, and much preferred, to provide the treated area **344** across the whole of the inner surfaces of the first and second walls **310**, **312** (that is, across the whole of the surfaces of the first and second walls **310**, **312** which oppose the bag portion **314**). This means that, during manufacture of the bags and subsequently during heat sealing of the closeable region there is no uncertainty as to whether the heat sealing which joins the various walls together is, or is not, in a treated area **344**. Of course, a treated area **344** is never formed on the internal surfaces of the third and fourth walls **316**, **318** which define the interior of the bag portion. Most preferably, where the first and second walls **310**, **312** are formed from a transparent material, the treated areas, especially printed areas, are also substantially transparent.

[0093] In a preferred form of the bags of this embodiment of the invention, the area **328A**, preferably the areas **320A** and optionally the areas **320B** and **322A** may, during manufacture be made somewhat wider than finally required. These areas may then be trimmed, such as with an automatic knife or other cutting device to remove a small excess of material. This then ensures that the bond between the various walls and between the walls and the closure flap(s) in these regions extends right to the very edge of the bag. This ensures that no crevices, recesses, channels or the like are left which might harbour foreign bodies or infectious agents (bacteria etc.) which could contaminate the contents of the bag portion **314**. This is of especial importance in region **328A** where the first wall **310**, is joined respectively to the closure flap **334** (FIG. **7**) or third wall **316** (FIG. **8**) and the second wall **312** is joined to the fourth wall **318**, as these regions are directly exposed to the product as it is being filled into the bag portion **318**.

[0094] A variation of the bag of this second aspect of the invention is shown in FIG. **8** in which features correspond-

ing or similar to those of FIG. **7** are given like reference numbers and features which differ are given reference numbers with the prefix "4". In FIG. **8**, an additional closure flap **434** is provided on an outer wall (first wall **310** or second wall **312**) of the bag **302**. This construction is especially desirable where, as indicated in the preceding paragraph, the edges of the bag have been trimmed during manufacture so that the bond between the various walls and closure flaps extends right to the edge of the bag **302**, most especially at end **328**. Because the various walls and closure flap(s) are bonded right to the edge of the bag **302**, it may be difficult for a user to obtain purchase or grip on one of the first or second walls **310**, **312** in order to separate the walls **310**, **312** from the bag portion **314**. The additional closure flap **434** allows such purchase or grip easily to be provided in that, on tearing or peeling back of the tearable or peelable portion of the closure flap **434**, the user has a substrate to grip while pulling the respective first and second walls **310**, **312** away from one another to separate them from the bag section **314**. In a further preferred variation, the wall lying below the closure flap **434** (first wall **310** or second wall **312**) may be provided with a mouth **442** in the form of a slit, or more preferably, in the form of a line of weakness which may be ruptured as, or after, the closure flap **434** is peeled or torn back. When the mouth **442** is opened the user is provided with an edge of the wall (**310** or **312**) which can be gripped directly for pulling the walls **310**, **312** away from one another.

[0095] In an alternative, but less preferred variation of the invention one or both of the walls **310**, **312** may be provided with a gripping tab, loop or the like which a user can grasp for separating the cover section **304** from the bag section **314**.

[0096] As noted above, FIG. **8** shows a further variation in that the walls **316**, **318** of the bag section **314** are of equal length. The mouth **432** for access to the interior of the bag section **314** is thus formed as a slit in wall **316** which is closed by closure flap **334**.

[0097] In use of the bags of this embodiment of the invention, the bag is preferably manufactured by heat sealing the first and second walls respectively to the third and fourth walls at their edges. Because the first and second walls comprises a treated area across the whole of their inner faces, the heat sealing of the walls renders them separable when desired. The third and fourth walls are also heat sealed at their edges, either contemporaneously with the heat sealing of the first and second walls to the third and fourth walls, or separately. In manufacture, no heat seal is formed between the third and fourth walls at the top end **328** of the bag. The bag portion **314** is then filled with the desired contents. A heat seal is applied in the closeable region to join the third and fourth walls together and so seal the contents within the bag section. This heat seal also further joins the first and second walls respectively to the third and fourth walls, the treated area of the first and second walls rendering this joint separable. The bag is then stored and/or transported as required. When access is required to the contents of the bag portion **314**, the first and second wall **310**, **312** are peeled away from the bag portion, with the assistance of the closure flap **434** if present. Access to the contents of the bag portion **314** is gained by peeling or tearing back the closure flap **334** and opening mouth **332** through which the product is dispensed.

[0098] Thus a particularly preferred plastic bag according to the second embodiment of the invention comprises:

[0099] i) a bag section comprising third and fourth opposed walls joined at their side and base edges and an open end by means of which the bag section may be filled with contents;

[0100] ii) a cover section comprising first and second opposed walls which are substantially co-extensive in width with the third and fourth walls, arranged to enclose the bag section and attached to the third and fourth walls at their side edges and upper edge;

[0101] iii) a closeable mouth defined in a wall of the bag section for access in use to the interior of the bag section;

[0102] iv) a closeable region, distinct from the mouth, including an end portion of the cover section and an end portion of the bag section proximate the open end of the bag section, within which closeable region the bag section may be sealed closed after filling;

wherein

[0103] (a) in the closeable region, the internal faces of the respective first and second walls are attachable to the adjacent external face of a wall of the bag section and

[0104] (b) the internal face of each of the first and second walls is treated to provide alternating printed and non-printed areas

whereby the attachment of the first and second walls to the bag section is such that the bag section is separable in use from the cover section without compromising the seal of the bag section in the closeable region.

[0105] The bag section may comprise a closure flap covering a mouth, the mouth providing access to the interior of the bag section. In this case, one of the first and second walls is attached to an outer surface of the closure flap. Part of the closure may also lie in the closable region.

[0106] In another variation of both the first and second embodiments of the invention, the third and/or fourth walls may be provided with a plurality of small holes 360 (FIG. 6), i.e. pin-holes of diameter not more than about 1 mm, and preferably substantially less. These holes are provided to allow air to escape from the interior of the bag section. The size and number of the holes is selected so that the air escapes gradually into the space between the third and fourth walls (and where present, the closure flap) and the first and second walls. The air then seeps or gradually escapes out of that space to the exterior. In this way, air is not retained in the bags of the invention when the filled bags are stacked such as on a pallet. The product contained in the bag is of course retained in the bag and does not substantially pass through the pin-holes. By allowing the air to escape, the filled bags can be stacked more stably and are less vulnerable to bursting under the pressure generated by bags higher up a stack.

[0107] In accordance with this aspect of the invention there is provided a plastic bag comprising:

[0108] i) an inner bag portion defined by third and fourth walls joined at their edges and base and having an open upper end;

[0109] ii) a cover portion enclosing the bag portion defined by first and second walls joined at their edges and base, and

[0110] iii) at least one region in which the cover portion is joined to the bag portion the third and/or fourth wall further comprising a plurality of pin-holes by means of which air can gradually escape from the bag portion when filled with contents into the space between the cover portion and the bag portion.

[0111] Preferably the cover portion and bag portion are separably joined to one another. In this respect, preferably at least one of the walls, more preferably the first and second walls include a treated region as discussed and defined above. Preferably also the bag of this aspect of the invention comprises a closure portion of the type defined and described above.

1. A plastic bag comprising:

i) a cover section comprising first and second opposed walls;

ii) a bag section comprising third and fourth opposed walls joined at their side and base edges and an open end by means of which the bag section may be filled with contents, the first and second walls being arranged to enclose the bag section;

iii) a closeable mouth defined in a wall of the bag section for access in use to the interior of the bag section;

iv) a closeable region, distinct from the mouth, including an end portion of the cover section and an end portion of the bag section proximate the open end of the bag section, within which closeable region the bag section may be sealed closed after filling;

wherein, in the closeable region, an internal face of at least one of the respective first and second walls is attached and/or attachable to an adjacent external face of a wall of the bag section, the attachment being such that the bag section is separable in use from the cover section without compromising the seal of the bag section in the closeable region.

2. A plastic bag as claimed in claim 1 wherein the open end of the bag section may operatively be sealed after filling by heat sealing the bag section walls together in the closeable region.

3. A plastic bag as claimed in claim 1 wherein, for attachment of the cover section to the bag section in said closeable region, an internal face of at least one of the respective first and second walls of the cover section is attachable to at least one external face of a bag section wall by heat sealing in the closeable region.

4. A plastic bag as claimed in claim 3 wherein at least one member selected from the group comprising the internal faces of the first and second walls and the respective external faces of the bag section walls comprises a first treated area in the closeable region, said first treated area being effective to limit the strength of the heat seal between the cover section and bag section.

5. A plastic bag as claimed in claim 4 wherein said first treated area comprises printed areas, the printed areas being resistant to heat sealing.

6. A plastic bag as claimed in claim 1 wherein the first and second walls are also separably attached respectively to the bag section walls in areas other than said closeable region.

7. A plastic bag as claimed in claim 6 wherein the first and second walls are removeably heat sealed respectively to the bag section walls in said separably attached areas.

8. A plastic bag as claimed in claim 1 wherein at least one of the first wall and the adjacent bag section wall and/or at least one of the second wall and the adjacent bag section wall comprises a second treated area, said second treated area being effective to limit the strength of the heat seal between respectively the first and third and the second and fourth walls in said separably attached areas.

9. A plastic bag as claimed in claim 8 wherein said second treated area comprises printed areas, the printed areas being resistant to heat sealing.

10. A plastic bag as claimed in claim 3, wherein said first treated area extends across the whole inner surface of the first and/or second wall.

11. A plastic bag as claimed in claim 10 wherein the first and second walls are also separably attached respectively to the bag section walls in areas other than said closeable region.

12. A plastic bag as claimed in claim 11 wherein the first and second walls are removeably heat sealed respectively to the bag section walls in said separably attached areas.

13. A plastic bag as claimed in claim 5 comprising, in a said treated area, alternate printed and non-printed areas.

14. A plastic bag as claimed in claim 13 wherein the area of the printed areas is greater than the area of the non-printed areas.

15. A plastic bag as claimed in claim 13 wherein the printed and non-printed areas alternate to define stripes across the closeable region and/or across the separably attached areas.

16. A plastic bag as claimed in claim 13 wherein the non-printed areas have a width of not more than about 2 mm.

17. A plastic bag as claimed in claim 13 wherein the printed areas have a width of not more than about 10 mm.

18. A plastic bag as claimed in claim 4 wherein the treated area comprises an embossed area of one or more of the walls.

19. A plastic bag as claimed in claim 1 wherein the cover section is longer than the bag section such that the cover section extends beyond the base end of the bag section, the first and second walls being joined to each other in said lengthwise extending portion.

20. A plastic bag as claimed in claim 1 wherein the width of the cover section is greater than the width of the bag section such that the cover section extends beyond the side edges of the bag section, the first and second walls being joined to each other in said widthwise extending portion.

21. A plastic bag as claimed in claim 6 wherein the width of the cover section is greater than the width of the bag section such that the cover section extends beyond the side edges of the bag section, the first and second walls being joined to each other in said widthwise extending portion.

22. A plastic bag as claimed in claim 1 further comprising:

a first closure flap overlying and closing said mouth defined in a wall of said bag section said first closure flap including a first attached region which is peelably attached to said bag section wall such that at least a portion of said first closure flap may be peeled away from said bag section wall across the peelably attached region to reveal the mouth, and, optionally, a second attached region spaced from the peelably attached

region in which second region said first closure flap is also attached to said bag section wall.

23. A plastic bag as claimed in claim 1 comprising:

a first closure flap overlying and closing said mouth defined in a wall of said bag section said first closure flap including a first region which is attached to a said bag section wall, said first closure flap including at least one line of weakness defining a tearable portion of said first closure flap within which tearable portion said first closure flap is not attached to the bag section wall and which tearable portion can be opened by tearing along the line of weakness to reveal the mouth; and, optionally, a second attached region spaced from the tearable portion in which second region said first closure flap is also attached to said bag section wall.

24. A plastic bag as claimed in claim 22 wherein the first closure flap extends into the closeable region.

25. A bag as claimed in claim 24 further comprising a closure flap;

wherein, for attachment of the cover section to the bag section in said closeable region, an internal face of at least one of the respective first and second walls of the cover section is attachable to at least one external face of a bag section wall by heat sealing in the closeable region;

wherein at least one member selected from the group comprising the internal faces of the first and second walls and the respective external faces of the bag section walls comprises a first treated area in the closeable region, said first treated area being effective to limit the strength of the heat seal between the cover section and bag section;

wherein the first closure flap is overlying and closing said mouth defined in a wall of said bag section said first closure flap including a first attached region which is peelably attached to said bag section wall such that at least a portion of said first closure flap may be peeled away from said bag section wall across the peelably attached region to reveal the mouth, and, optionally, a second attached region spaced from the peelably attached region in which second region said first closure flap is also attached to said bag section wall; and

wherein a first treated area is formed on the first closure flap instead of a treated area of the bag section.

26. A plastic bag according to claim 1 wherein on or both of the respective first and second walls of the cover section is/are adhered to the bag section proximate the open end of the bag section.

27. A plastic bag as claimed in claim 26 wherein the cover section is adhered to the bag section at marginal portions of the closeable region.

28. A plastic bag as claimed in claim 1 further comprising a second closeable mouth defined in the first or second wall of the cover section for access in use to the bag section.

29. A plastic bag as claimed in claim 1 further comprising:

a second closure flap including a first region which is peelably attached to said cover section wall such that at least a portion of the closure flap may be peeled away from said cover section wall across the peelably attached region and a second attached region spaced

from the peelably attached region in which second region the second closure flap is also attached to said cover section wall.

30. A plastic bag as claimed in claim 1 further comprising: a second closure flap including a first region which is attached to said cover section wall, the second closure flap including at least one line of weakness defining a tearable portion of the closure flap within which tearable portion the closure flap is not attached to said cover section wall and which tearable portion can be opened by tearing along the line of weakness and a second attached region spaced from the tearable portion in which second region the second closure flap is also attached to said cover section wall.

31. A plastic bag as claimed in claim 29 wherein the second closure flap is arranged to cover the second mouth.

32. A plastic bag as claimed in claim 1 further comprising gripping means formed in or on, or attached to the first or second walls, to facilitate gripping of said walls on separation of the cover section from the bag section.

33. A method of handling a flowable product comprising:

- i) providing a bag as claimed in claim 1;
- ii) filling the bag section with the flowable product through the open end of the bag; and
- iii) applying heat sealing means to the closeable region thereby to heat seal the bag section walls together to sealingly close the bag section and to heat seal the first and/or second walls to the bag section walls to separably attach cover section and bag section together.

34. A method as claimed in claim 33 further comprising:

- iv) separating the cover section from the bag section in the closeable region;
- v) if necessary, separating the cover section from the bag section outside the closeable region and
- vi) withdrawing the bag section from the cover section.

35. A plastic bag comprising:

- i) a cover section comprising first and second opposed walls;
- ii) a product containing bag section comprising third and fourth opposed walls joined at their side and base edges, the first and second walls being arranged to enclose the bag section;
- iii) a closeable mouth defined in a wall of the bag section for access in use to the interior of the bag section;
- iv) a sealing region, distinct from the mouth, including an end portion of the cover section and an end portion of the bag section within which sealing region the bag section is sealed closed after filling bag section with product;

wherein, in the sealing region, an internal face of at least one of the respective first and second walls is attached to an adjacent external face of a wall of the bag section, the attachment being such that the bag section is separable in use from the cover section without compromising the seal of the bag section in the sealing region.

36. A plastic bag as claimed in claim 35 wherein, within the sealing region the respective first and second walls of the

cover section are attached to at least one of the external faces of the respective bag section walls of the bag section by means of a heat seal formed contemporaneously with the heat seal which seals the bag section walls.

37. A plastic bag as claimed in claim 36 wherein at least one of the internal faces of the first and second walls and the external faces of the bag section walls comprises a treated area in the sealing region, the treated area being effective to limit the strength of the heat seal between the cover section and bag section.

38. A plastic bag as claimed in claim 35 further comprising:

- a first closure flap overlying and closing said mouth defined in a wall of said bag section said first closure flap including a first attached region which is peelably attached to said bag section wall such that at least a portion of said first closure flap may be peeled away from said bag section wall across the peelably attached region to reveal the mouth, and, optionally, a second attached region spaced from the peelably attached region in which second region said first closure flap is also attached to said bag section wall.

39. A plastic bag as claimed in claim 35 comprising:

- a first closure flap overlying and closing said mouth defined in a wall of said bag section said first closure flap including a first region which is attached to a said bag section wall, said first closure flap including at least one line of weakness defining a tearable portion of said first closure flap within which tearable portion said first closure flap is not attached to the bag section wall and which tearable portion can be opened by tearing along the line of weakness to reveal the mouth; and, optionally, a second attached region spaced from the tearable portion in which second region said first closure flap is also attached to said bag section wall.

40. A plastic bag as claimed in claim 38 wherein the first closure flap extends into the closeable region.

41. A bag as claimed in claim 40

wherein at least one of the internal faces of the first and second walls and the external faces of the bag section walls comprises a treated area in the sealing region, the treated area being effective to limit the strength of the heat seal between the cover section and bag section; and

further comprising:

- a first closure flap overlying and closing said mouth defined in a wall of said bag section said first closure flap including a first attached region which is peelably attached to said bag section wall such that at least a portion of said first closure flap may be peeled away from said bag section wall across the peelably attached region to reveal the mouth, and, optionally, a second attached region spaced from the peelably attached region in which second region said first closure flap is also attached to said bag section wall;

wherein a first treated area is formed on the first closure flap instead of a treated area of the bag section.

42. (canceled)