



US009265902B2

(12) **United States Patent**
Payton et al.

(10) **Patent No.:** **US 9,265,902 B2**

(45) **Date of Patent:** ***Feb. 23, 2016**

(54) **APPARATUS FOR MEASURING PROPERTIES OF GASES SUPPLIED TO A PATIENT**

(71) Applicant: **Fisher & Paykel Healthcare Limited**, Auckland (NZ)

(72) Inventors: **Matthew Jon Payton**, Auckland (NZ); **Kevin Peter O'Donnell**, Auckland (NZ); **Andrew Baden Clark**, Auckland (NZ); **Christopher Simon James Quill**, Auckland (NZ); **Peter Geoffrey Hawkins**, Auckland (NZ)

(73) Assignee: **Fisher & Paykel Healthcare Limited**, Auckland (NZ)

(*) Notice: Subject to any disclaimer, the term of this patent is extended or adjusted under 35 U.S.C. 154(b) by 244 days.

This patent is subject to a terminal disclaimer.

(21) Appl. No.: **13/908,952**

(22) Filed: **Jun. 3, 2013**

(65) **Prior Publication Data**

US 2013/0306075 A1 Nov. 21, 2013

Related U.S. Application Data

(63) Continuation of application No. 11/572,822, filed as application No. PCT/NZ2005/000219 on Aug. 19, 2005, now Pat. No. 8,453,641.

(30) **Foreign Application Priority Data**

Aug. 20, 2004 (NZ) 534853

(51) **Int. Cl.**

A61M 11/00 (2006.01)

A61M 16/00 (2006.01)

(Continued)

(52) **U.S. Cl.**

CPC **A61M 16/00** (2013.01); **A61M 16/1075** (2013.01); **A61M 16/1095** (2014.02); **A61M 16/16** (2013.01); **A61M 16/161** (2014.02); **A61M 2016/102** (2013.01); **Y10S 261/65** (2013.01)

(58) **Field of Classification Search**

CPC A61M 2016/0027; A61M 16/0051; A61M 16/0066; A61M 16/0816; A61M 2016/0036; A61M 16/00; A61M 16/1075; A61M 16/16; A61M 2016/102; A61M 16/1095; A61M 16/161; Y10S 261/65
USPC 128/204.21, 204.22, 204.18; 261/129, 261/131, 142, DIG. 65
See application file for complete search history.

(56) **References Cited**

U.S. PATENT DOCUMENTS

3,913,379 A 10/1975 Rusz et al.
4,686,354 A 8/1987 Makin

(Continued)

FOREIGN PATENT DOCUMENTS

CN 1370085 9/2002
DE 4020522 A1 1/1992

(Continued)

OTHER PUBLICATIONS

JP Examination Report; JP2013-168353; dated Jun. 24, 2014; 6 pages.

(Continued)

Primary Examiner — Steven Douglas

(74) *Attorney, Agent, or Firm* — Knobbe, Martens, Olson & Bear, LLP

(57) **ABSTRACT**

The gases temperature supplied to a patient when the patient is undergoing treatment such as oxygen therapy or positive pressure treatment for conditions such as Obstructive Sleep Apnea (OSA) or Chronic Obstructive Pulmonary Disease (COPD) is often measured for safety and to enable controlling of the humidity delivered to the patient. The apparatus is related to measurement of properties, particularly temperature (thermister 23), of gases flowing through a heated tube (3), supplying gases to a patient, which utilizes the heating wire (21, 28) within the tube.

33 Claims, 4 Drawing Sheets

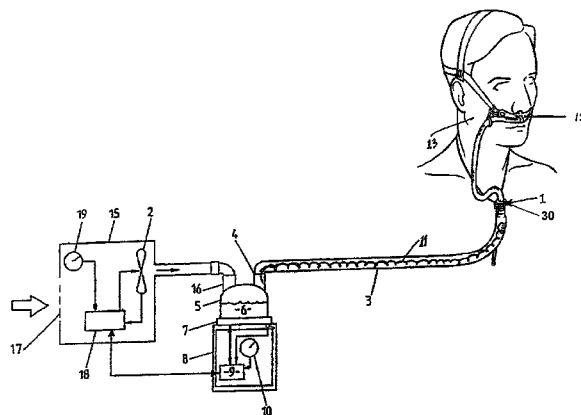

(51) **Int. Cl.**
A61M 16/10 (2006.01)
A61M 16/16 (2006.01)

(56) **References Cited**

U.S. PATENT DOCUMENTS

4,695,955	A	9/1987	Faisandier	
4,736,090	A	4/1988	De Broeck et al.	
5,230,331	A	7/1993	Rusz et al.	
5,537,996	A	7/1996	McPhee	
6,078,730	A	6/2000	Huddart et al.	
6,109,782	A	8/2000	Fukura et al.	
6,167,883	B1	1/2001	Beran et al.	
6,272,933	B1	8/2001	Gradon et al.	
6,349,722	B1	2/2002	Gradon et al.	
6,584,972	B2	7/2003	McPhee	
6,694,974	B1	2/2004	George-Gradon et al.	
7,140,367	B2	11/2006	White et al.	
7,588,186	B2	9/2009	Steffen et al.	
7,933,780	B2	4/2011	De La Huerga	
7,987,847	B2	8/2011	Wickham	
8,063,343	B2	11/2011	McGhin et al.	
2002/0083947	A1*	7/2002	Seakins	128/204.17
2004/0182392	A1*	9/2004	Gerder et al.	128/204.22
2006/0278221	A1*	12/2006	Schermeier et al.	128/204.18

FOREIGN PATENT DOCUMENTS

DE	19647548	A1	5/1998
DE	20202906		2/2002
EP	1579884	A1	9/2005

GB	2173274	10/1986
JP	S61-294479	12/1986
JP	H02-193680	7/1990
JP	U H07-16955	3/1995
JP	H07-204273	8/1995
JP	H10-506544	6/1998
JP	H11-057009	3/1999
JP	2002-291655	10/2002
JP	2003-516825	5/2003
JP	3475261	12/2003
WO	WO 9221163	11/1992
WO	WO96/00528	1/1996
WO	WO 2004/105848	12/2004
WO	WO 205/021076	3/2005
WO	WO 2006/092001	9/2006

OTHER PUBLICATIONS

JP Examination Report; JP2013-168354; dated Jun. 24, 2014; 5 pages.
 JP Examination Report; JP2012-020278; dated Feb. 3, 2015, 4 pages.
 Letter transmitting Examiner's Report in Canadian Application No. 2576409, dated Mar. 31, 2011, in 2 pages.
 Examiner's Report in Canadian Application No. 2576409, dated Nov. 1, 2012, by Dan Rempel, in 2 pages.
 Chinese Examination Report of CN Application No. 200580028386. 6, with English translation of pertinent portion, dated Apr. 12, 2012, in 8 pages.
 Chinese Examination Report of CN Application No. 200580028386. 6, cover letters dated Jul. 19, 2011 and Aug. 12, 2011, with English translation of pertinent portions of examination report.

* cited by examiner

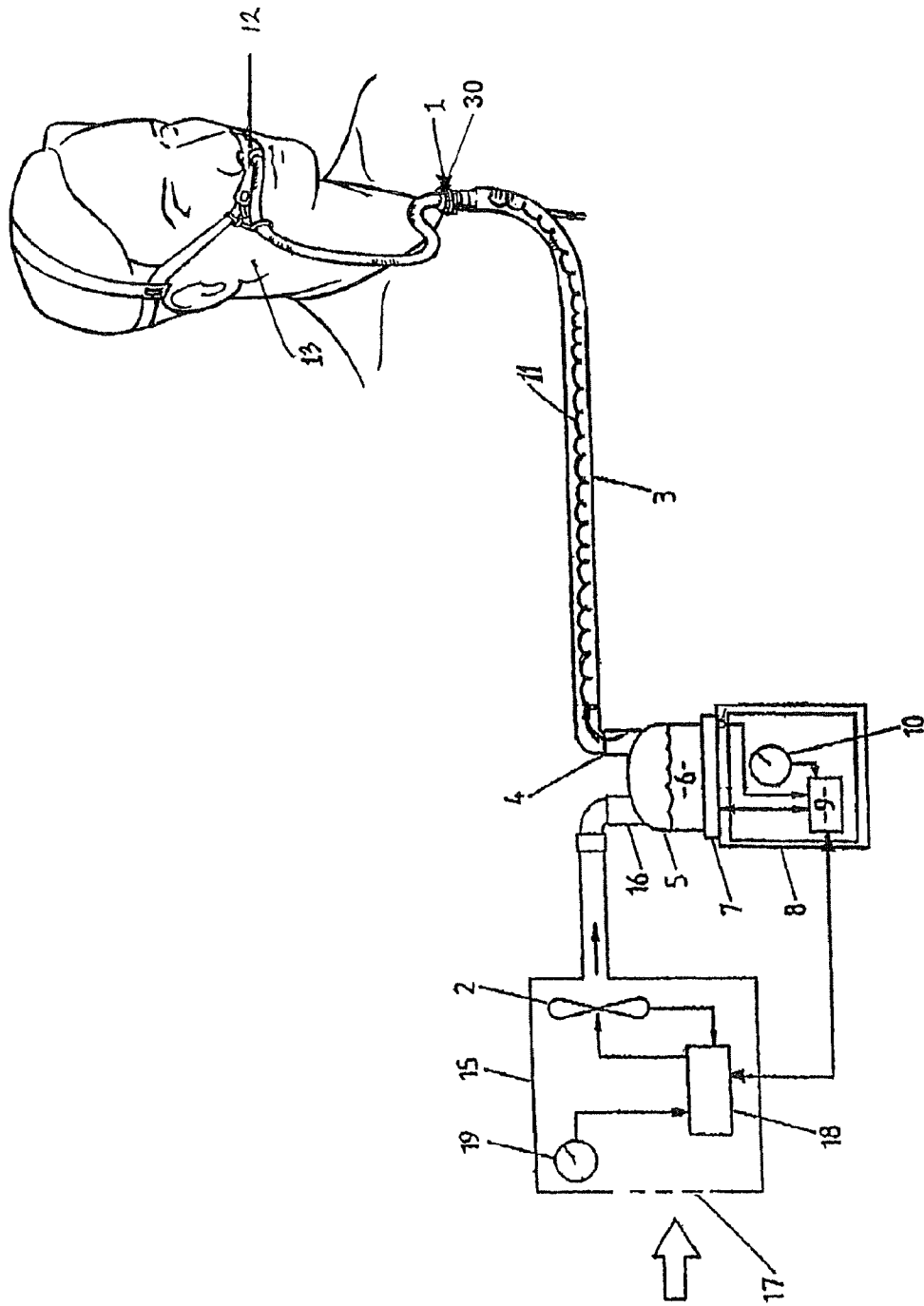

Figure 1

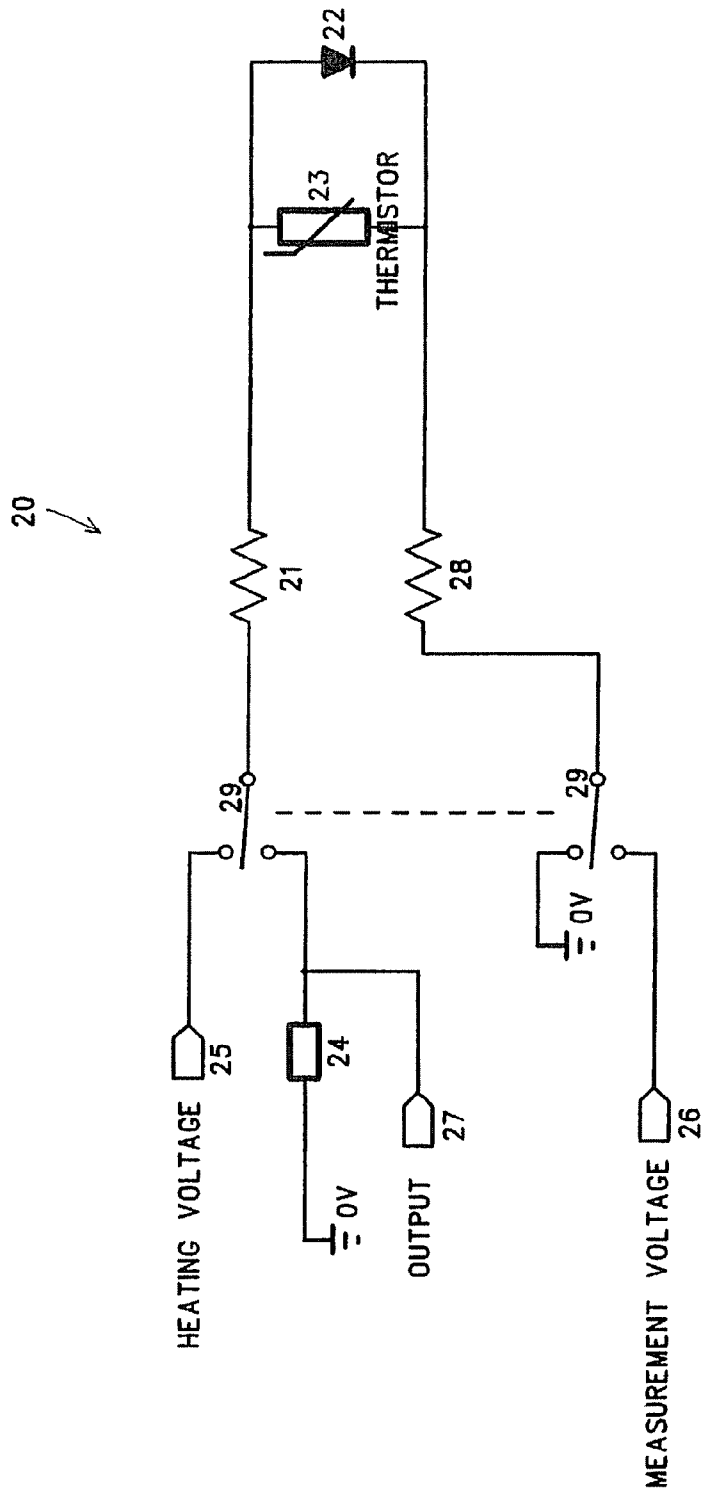

Figure 2

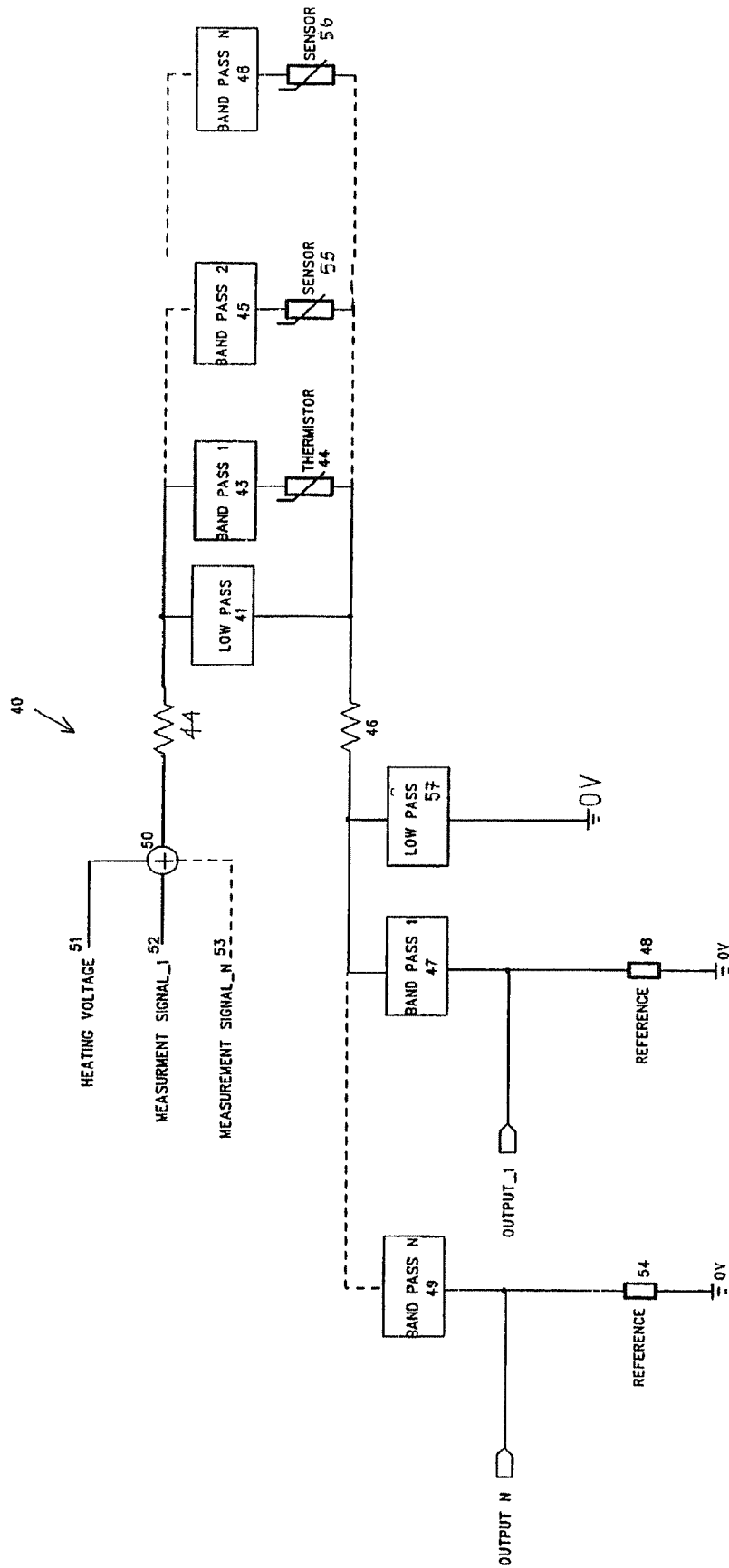

Figure 3

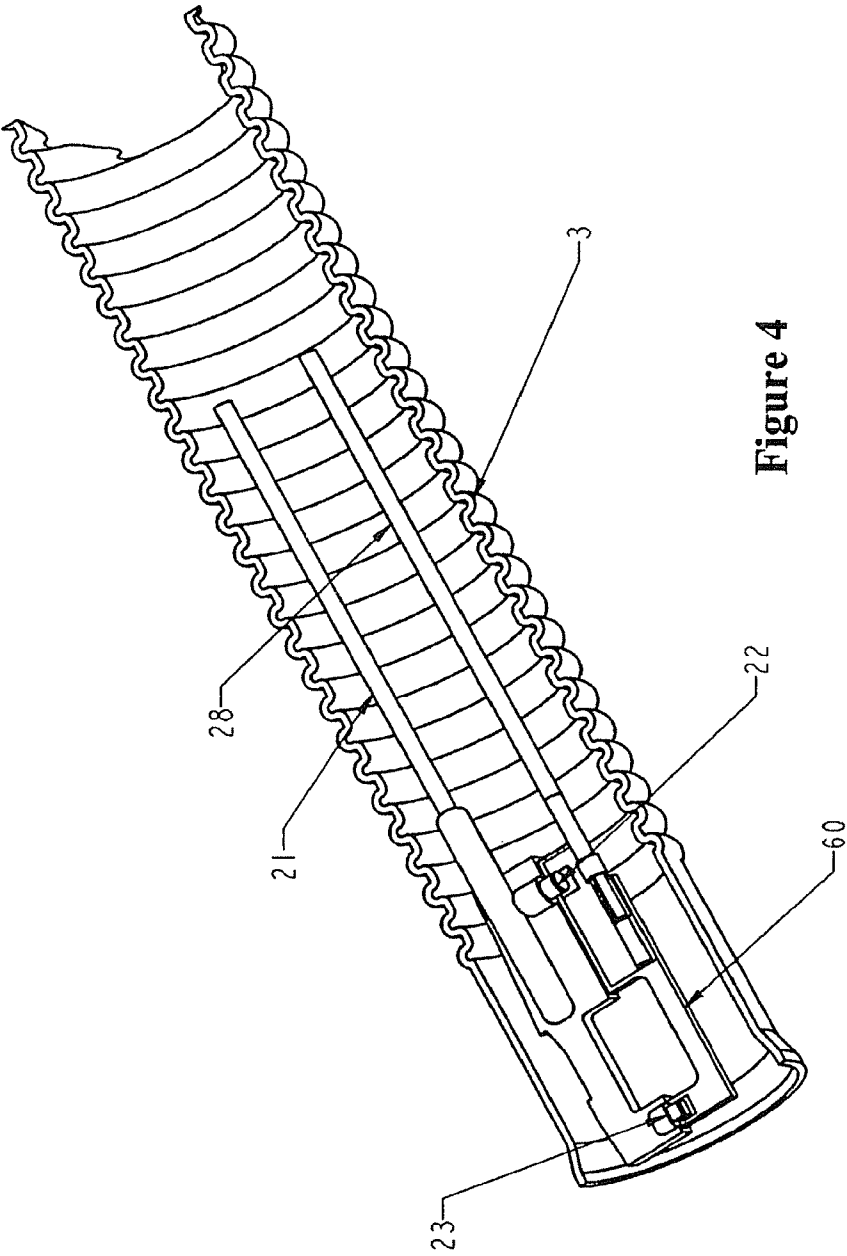

Figure 4

APPARATUS FOR MEASURING PROPERTIES OF GASES SUPPLIED TO A PATIENT

INCORPORATION BY REFERENCE TO ANY PRIORITY APPLICATIONS

Any and all applications for which a foreign or domestic priority claim is identified in the Application Data Sheet as filed with the present application are hereby incorporated by reference under 37 CFR 1.57.

This application is a continuation of U.S. patent application Ser. No. 11/572,822, filed Oct. 18, 2007, now U.S. Pat. No. 8,453,641, issued Jun. 4, 2013, which is a National Phase filing of PCT/NZ2005/000219, having an International filing date of Aug. 19, 2005, which claims priority of NZ534853 having a filing date of Aug. 20, 2004.

BACKGROUND

1. Field

This invention relates to an apparatus for measuring properties, such as temperature and humidity, of gases being supplied to a patient. Humidifiers are commonly controlled by measuring the temperature of gas at two points, adjacent to the output of the humidifier and proximal to the patient. This invention predominantly relates to the measurement of temperature of gas supplied to a patient at a point proximal to the patient.

2. Description of the Related Art

The gases temperature supplied to a patient when the patient is undergoing treatment such as oxygen therapy or positive pressure treatment for conditions such as Obstructive Sleep Apnea (OSA) or Chronic Obstructive Pulmonary Disease (COPD) is often measured for safety and to enable controlling of the humidity delivered to the patient. Measurement of temperature near the patient is commonly performed using a probe inserted into the breathing tube, such as that of Fisher & Paykel Healthcare Limited, U.S. Pat. Nos. 6,272,933 and 6,584,972. Such a temperature probe is connected to the humidifier through a cable that runs external to the breathing circuit. This approach has some drawbacks. In particular, the user must correctly install the temperature probe. If the probe is not correctly installed then the humidification system may malfunction which may increase risk to the patient. Existing end of breathing tube sensors require sensor wires to be run down the outside of the breathing tube. This lowers reliability of the sensors due to the vulnerability of these wires. Alternatively, if these wires are run down the inside of the breathing tube there would be an increase of the resistance to airflow and the hygiene of the breathing circuit would be lowered.

SUMMARY

It is an object of the present invention to provide a method of measuring properties of gases supplied to a patient that goes some way to overcoming the abovementioned disadvantages in the prior art or which will at least provide the industry with a useful choice.

Accordingly in a first aspect the present invention consists in an apparatus for measuring properties of gases being supplied to a patient comprising:

- a gases supply,
- at least one delivery conduit including a heater wire for heating said conduit,
- wherein said heater wire is utilised in an electrical circuit to determine said properties of said gases.

Preferably said electrical circuit is connected in series with said heater wire and provides a measurement or enables a calculation of an indication of at least one of temperature, humidity, pressure and composition of said gases.

5 Preferably said electrical circuit is mounted and sealed on a printed circuit board that at least partially extends into the gases supplied to said patient through said at least one delivery conduit.

10 Preferably said electrical circuit is at least partially moulded into the wall of said delivery conduit.

Preferably said electrical circuit includes a sensing means with known properties at ambient temperature such that said sensing means can be matched with said at least one delivery conduit.

15 Preferably said sensing means is a temperature sensor.

Preferably said electrical circuit includes at least one measuring means in series with said heater wire.

Preferably said at least measuring means is a temperature measuring means.

20 Preferably said temperature measuring means includes a thermistor and diode in parallel and a reference resistor.

Preferably said thermistor and said diode are located at the end of said delivery conduit near to said patient and said reference resistor is included in said gases supply means.

25 Preferably said gases supply means includes a device to supply gas flow, such as a blower, and a humidifier to humidify said gases from said blower.

Preferably said gases supply means is a humidifier.

30 Preferably said electrical circuit includes a gases property measuring means.

Preferably said gases property measuring means includes at least one of a sensor, band pass filter or thermistor and at least one reference resistor.

35 Preferably said at least one of a sensor, band pass filter or thermistor are located at the end of said delivery conduit near to said patient and said at least one reference resistor and at least one band pass filter is included in said gases supply means.

40 The invention consists in the foregoing and also envisages constructions of which the following gives examples.

BRIEF DESCRIPTION OF THE DRAWINGS

Preferred forms of the present invention will now be described with reference to the accompanying drawings.

45 FIG. 1 is an illustration of a respiratory humidifier system that may be used with the method of the present invention of measuring temperature of gases supplied to a patient.

FIG. 2 is a circuit diagram of the electronics enabling the measurement of the temperature of gases to a patient, where the circuit is utilised when the system of the present invention is utilising DC heating and measuring voltages.

50 FIG. 3 is a circuit diagram of the electronics enabling the measurement of the temperature of gases to a patient, where the circuit is utilised when the system of the present invention is utilising DC or AC voltages for the heating and signal voltages.

60 FIG. 4 is a cut away of a conduit including a circuit of the present invention on a printed circuit board and residing with the conduit in the area of gases flow.

DETAILED DESCRIPTION

The present invention seeks to measure various properties, 65 for example temperature or humidity, at the end of a gas delivery tube or conduit using sensors mounted on a wire, such as a wire used for heating the gases flow through the tube

3

or conduit, where the wire resides within the delivery tube or conduit. A heated tube with a heating wire such as that described in Fisher & Paykel Healthcare Limited U.S. Pat. No. 6,078,730 or any other similar tube and heating wire could be utilised with the present invention.

Referring to FIG. 1 a ventilation and humidifying system as might be used with the present invention is shown. A patient 13 is receiving humidified and pressurised gases through a nasal cannula 12 connected to a humidified gases transportation pathway or inspiratory conduit 3 that in turn is connected to a humidifier 8 (including humidification chamber 5) supplied with gases from a blower 15 or other appropriate gases supply means.

The inspiratory conduit 3 is connected to the outlet 4 of the humidification chamber 5 that contains a volume of water 6. The humidification chamber 5 is preferably formed from a plastics material and may have a highly heat conductive base (for example an aluminium base) that is in direct contact with a heater plate 7 of humidifier 8. The humidifier 8 is provided with control means or an electronic controller 9 that may comprise a microprocessor based controller executing computer software commands stored in associated memory. Gases flowing through the inspiratory conduit 3 are passed to the patient by way of the nasal cannula 12, but may also be passed to the patient by way of other patient interfaces such as a nasal or full face mask.

The controller 9 receives input from sources such as user input means or dial 10 through which a user of the device may, for example, set a predetermined required value (preset value) of humidity or temperature of the gases supplied to patient 13. In response to the user set humidity or temperature value input via dial 10 and other possible inputs such as internal sensors that sense gases flow or temperature, or by parameters calculated in the controller, controller 9 determines when (or to what level) to energise heater plate 7 to heat the water 6 within humidification chamber 5. As the volume of water 6 within humidification chamber 5 is heated, water vapour begins to fill the volume of the chamber above the surface of the water and is passed out of the humidification chamber 5 outlet 4 with the flow of gases (for example air) provided from a gases supply means or blower 15 which enters the humidification chamber 5 through inlet 16.

The blower 15 may be provided with a variable speed pump or fan 2 which draws air or other gases through the blower inlet 17. The speed of the variable speed pump or fan 2 may be controlled by a further control means or electronic controller 18 which responds either to inputs from controller 9 or to user-set predetermined required values (preset values) of pressure or fan speed, via dial 19. Alternatively, the function of this controller 18 can be combined with the other controller 9.

A heating element or wire 11 is preferably provided within, around and throughout the conduit or tubing 3 to help prevent condensation of the humidified gases within the conduit. Such condensation is due to the temperature of the walls of the conduit being close to the ambient temperature, (being the temperature of the surrounding atmosphere) which is usually lower than the temperature of the humidified gases within the conduit. The heater element effectively replaces the energy lost from the gases through conduction and convection during transit through the conduit. Thus the conduit heater element ensures the gases delivered are at an optimal temperature and humidity.

Such a heater wire is commonly driven either with direct current (DC) or alternating current (AC) and in both cases the heating voltage is usually switched on and off to control the power applied to the heating element. In the present invention

4

the heating element 11, which is most preferably a wire, is used along with an electronic circuit to determine properties of the gases supplied to the patient. The circuit (20 or 40 in FIGS. 2 and 3) is preferably connected in series with the heater wire 11. The circuit may be on a printed circuit board, or wired within a housing that may be a plastic moulding in the gases flow, or a circuit board that is at least partially moulded within the wall of the conduit or tubing 3. The properties that may be measured include temperature, pressure, gas composition and humidity. Two embodiments of the present invention are described below, one that operates using only a DC heating voltage and the other that can operate with a DC or AC heating voltage.

DC Heating Voltage

FIG. 2 shows a circuit 20 that may be utilised for carrying out the method of measuring temperature of the present invention. When a DC heating voltage 25 is applied to the heater wire the diode 22 conducts and current flows through the heater wire 21, 28 and the heater wire functions as normal and provides heating to the delivery tube 3. When the heating voltage 25 is switched off using switch 29, a measurement voltage 26, which has opposite polarity to the heating voltage 25 is applied to the heater wire. In this case, the current in the heater wire 21, 28 does not flow through the diode 22 but flows through the thermistor 23 and through a reference resistor 24. The voltage across the reference resistor 24 can then be measured at the output 27 and the temperature of the gases determined. The voltage measurement 27 across the reference resistor, 24, is converted to a temperature using a look up table or an equation to calculate a value for temperature. This is similar to a commonly used technique where the thermistor 23 forms a potential divider with the reference resistor 24.

More generally, the thermistor may be replaced by an impedance (for example, a resistor and a capacitive sensor) for pressure or humidity measurement. Either the impedance can be measured by measuring the voltage across the reference resistor 24 or the rise-time could be determined by looking at the voltage across the reference resistor 24 in time.

Part of the circuit 20 would be included in the delivery conduit 3 and in particular the diode 22 and thermistor 23 (in parallel with one another) are preferably placed in series with the heater wire 21, 28 at a point in the heater wire at or near the end 30 (nearest the user 13, see FIGS. 1, 2 and 4) of the delivery tube 3, for example they may be interconnected on a printed circuit board, overmoulded with plastic for sealing and mounted in the gases stream through the delivery conduit as shown in FIG. 4. Furthermore, the circuit may be formed by interconnected parts in a housing, for example, a plastic housing, that protrudes from the plastic wall of the delivery tube into the gases flow through the conduit, in order to measure that gases properties. All other parts of the circuit 20 including the reference resistor 24 and the switching circuitry 29 would be included in the control circuitry of the humidifier 8.

The thermistor's value can be chosen to have different resistance curves with known properties at ambient temperature. The choice of a particular thermistor value for use with the circuit allows identification by the control system of the present invention and matching of that thermistor value with a specific conduit or tubing 3. Such that different thermistor values can be matched with a particular and appropriate conduit types and upon connection of the conduit to a humidifier or blower device, the control system can identify that thermistor and apply the appropriate control strategy to the heating of the conduit.

AC or DC Heating Voltage

The circuit shown in FIG. 2 is intended to be used when a DC heating voltage is used in conjunction with the heater wire, delivery conduit and system as shown in FIG. 1. An alternative embodiment of a circuit 40 that would provide measurement of the gases properties, such as temperature and is suitable for AC and DC voltages, is shown in FIG. 3. A number of voltage signals 51, 52, 53, which are at different frequencies, are added together at an adder 50. These signals include at least one heating signal 51 and at least one measuring signal 53. The combination of these signals passes down the heater wire 44, creating currents (heating and measuring) in the heater wire 44. A number of parallel paths are established 41, 43, 45 each containing a filter (for example, as shown in FIG. 3, one low pass filter 41 and three band pass filters 43, 45, 48) that each pass a different frequency range. These parallel paths (that is, filters, thermistors and/or sensors) are preferably located at the end 30 of the delivery tube 3, in a similar manner as described in relation to FIG. 2. The parallel paths allow the heating current to be passed through a different path to the measurement currents. It also allows multiple measurement signals to be passed through the heater wire so that different properties of the gases (e.g. temperature, pressure, humidity, composition) may be measured.

The heating and measurement currents return through the heater wire 46 and can be filtered through a number of measurement filters 47, 49, 57 in parallel that pass frequency bands that correspond to the filters, 41, 43, 45 located at the end 30 of the tube 3. The heating current takes a different path than the measurement currents. The measurement currents each take a different path depending on their frequency and this allows each measurement current to be measured by passing it through a reference resistor 48, 54 or similar. Again a look up table or equation may be used to convert the voltage across the reference resistor 48, 54 to, for example, a temperature. In the preferred embodiment of the present invention the measurement filters 47, 49, 57 would be included in the humidifier 8 control circuitry.

In a further embodiment one or more of the sensing elements 55, 56 at the end 30 of the delivery tube 3 could be replaced by a fixed impedance to allow identification of the tube so that different control algorithms can be used for different conduits or tubes.

FIG. 4 shows a cutaway view of a conduit 3 with a printed circuit board 60 housing the parts to one of the circuits of the present invention described above with reference to FIG. 2 or 3. The circuit board 60 is connected to the heating wires 21, 28 and as such is positioned within the conduit 3. In this manner, the thermistor 23 included on the board 60 is exposed to the gases flowing through the conduit 3 and can provide measurements of the properties of the gases.

The circuits and method of the present invention can be applied to a number of applications of these technologies for humidification and breathing circuit products. For example, the measurement of the temperature or humidity at the end of the delivery tube (or in a patient interface, for example, nasal cannula or mask) can be used to better control the humidifier, such that a more accurate temperature of gases can be supplied to the patient, providing optimal patient comfort and therapy. Additionally, other gases properties may be measured, such as the gases pressure or gas composition near the patient.

The apparatus of the present invention eliminates the need for external wires for sensing gases properties, as is required by the prior art. Furthermore the apparatus of the present invention only uses two pins or contacts (as opposed to four pins as used in current heated tube implementations). This

means the system of the present invention is likely to be more reliable as the contacts/pins are likely to be less prone to breakage. The utilisation of the heater wire for measuring gases properties may also reduce the cost of the breathing tube 3 and associated parts, especially if the breathing tube is to be disposable.

What is claimed is:

1. A conduit for supplying gases, the conduit comprising:
 - a proximal end configured to connect to a source of breathing gases;
 - a distal end configured to connect to a patient interface;
 - a wall defining a lumen for delivering a flow of gases to a patient;
 - a wire provided within or around the conduit and extending at least a portion of a length of the conduit, the length of the conduit extending from a proximal portion of the conduit to a distal portion of the conduit; and
 - a gases property sensor configured to measure at least one property of the flow of gases and positioned at the distal portion of the conduit, the gases property sensor connected to the wire, and the gases property sensor disposed within a housing and within the flow of gases such that the gases property sensor is able to measure the at least one property of the flow of gases.
2. The conduit of claim 1, wherein the gases property sensor comprises at least one of a thermistor or a capacitive sensor.
3. The conduit of claim 1, wherein the gases property sensor is configured to measure at least one of temperature, pressure, gas composition, or humidity of the flow of gases.
4. The conduit of claim 1, wherein the at least a portion of the length of the conduit is substantially the length of the conduit.
5. An apparatus configured to supply a stream of gases to a patient, the apparatus comprising:
 - a gases supply;
 - a conduit configured to connect to the gases supply and to deliver the stream of the gases to the patient;
 - a wire located throughout a length of the conduit;
 - an electrical circuit connected to the wire, the electrical circuit configured to provide a signal to a controller through the wire indicative of at least one property of the stream of gases, the controller configured to determine the at least one property of the stream of gases, wherein at least a portion of the electrical circuit is configured to be positioned within the stream of gases; and
 - an overmolding enclosing at least part of the electrical circuit, the overmolding extending into a region conveying the stream of gases through the conduit.
6. The apparatus of claim 5, wherein the overmolding comprises a housing protruding from a wall of the conduit into the stream of gases.
7. The apparatus of claim 6, wherein the housing protrudes beyond the wall of the conduit.
8. The apparatus of claim 5, wherein the electrical circuit is at least partially molded into a wall of the conduit.
9. The apparatus of claim 5, wherein the electrical circuit comprises at least one of a thermistor, a resistor, or a capacitive sensor.
10. The apparatus of claim 9, wherein the at least one of the thermistor, the resistor, or the capacitive sensor is positioned in the conduit at or near a middle of a lumen formed by a wall of the conduit, and wherein the stream of gases is delivered through the lumen.
11. The apparatus of claim 5, wherein the electrical circuit is positioned on a circuit board, and wherein the overmolding encloses at least part of the circuit board.

7

12. The apparatus of claim 5, wherein the electrical circuit is mounted on a circuit board that at least partially extends into the stream of gases supplied to the patient through the conduit.

13. The apparatus of claim 5, wherein the electrical circuit is configured to measure at least one of temperature, pressure, gas composition, or humidity of the stream of gases.

14. The apparatus of claim 5, wherein the conduit is configured to connect to the gases supply at a first end of the conduit and to connect to a patient interface at a second end of the conduit, the patient interface configured to deliver the gases stream to the patient, and wherein the length of the conduit is substantially from the first end to the second end.

15. The apparatus of claim 14, wherein the overmolding is disposed at or near the second end of the conduit.

16. The conduit of claim 1, wherein the gases property sensor is on a circuit board.

17. The conduit of claim 16, wherein at least a portion of the circuit board is disposed within a plastic molding at least partially forming the housing.

18. The conduit of claim 17, wherein the circuit board is at least partially molded within the wall of the conduit.

19. The conduit of claim 1, wherein the housing protrudes beyond the wall of the conduit into the lumen.

20. The conduit of claim 1, wherein the gas property sensor is positioned at or near a radial center of the lumen.

21. The conduit of claim 1, further comprising a diode connected to the wire and in parallel electrical communication with the gases property sensor, wherein when an electrical current is applied to the wire in a first polarity, the electrical current flows through the diode such that the wire provides heat to the conduit, and wherein when the electrical current is applied to the wire in a second polarity opposite from the first polarity, the electrical current does not flow through the diode and flows through the gases property sensor.

22. The conduit of claim 21, wherein the diode is positioned at the distal portion of the conduit.

23. The conduit of claim 1, further comprising:
 a first filter connected to the wire and in series electrical communication with the gases property sensor, the first filter configured to pass through an electrical signal of a first frequency range driven through the wire;
 an other gases property sensor configured to measure at least one other property of the flow of gases and positioned at the distal portion of the conduit, the other gases property sensor connected to the wire in parallel electrical communication with the gases property sensor, and the other gases property sensor disposed within the housing and within the flow of gases such that the other gases property sensor is able to measure the at least one other property of the flow of gases; and
 a second filter connected to the wire and in series electrical communication with the other gases property sensor, the second filter configured to pass through an electrical signal of a second frequency range driven through the wire,

wherein the electrical signal of first frequency range is associated with measuring the at least one property of the flow of gases, and

wherein the electrical signal of the second frequency range is associated with measuring the at least one other property of the flow of gases.

24. The conduit of claim 1, further comprising:
 a third filter connected to the wire and in parallel electrical communication with the first and second filters, the third

8

filter configured to pass through an electrical signal of a third frequency range driven through the wire, wherein the electrical signal of the third frequency range is associated with providing heat to the conduit via the wire.

25. The conduit of claim 2, wherein the gases property sensor comprises a resistor and the capacitive sensor.

26. The conduit of claim 17, wherein the plastic molding protrudes from the wall of the conduit into the flow of gases.

27. The apparatus of claim 5, wherein the gases supply includes the controller configured to determine the at least one property of the stream of gases.

28. The apparatus of claim 5, wherein the electrical circuit further comprises a sensor and a diode, the sensor configured to provide the signal to the controller through the wire indicative of the at least one property of the stream of gases, the diode in parallel electrical communication with the sensor, wherein when an electrical current is applied to the wire in a first polarity, the electrical current flows through the diode such that the wire provides heat to the conduit, and wherein when the electrical current is applied to the wire in a second polarity opposite from the first polarity, the electrical current does not flow through diode and flows through the sensor.

29. The apparatus of claim 28, wherein the diode is positioned at a distal portion of the conduit, the distal portion configured to connect to a patient interface.

30. The apparatus of claim 28, wherein the controller comprises a reference resistor in electrical communication with the sensor via the wire, wherein when the electrical current is applied to the wire in the second polarity and the electrical current flows through the sensor, the controller is configured to determine the at least one property of the flow of gases via the reference resistor.

31. The apparatus of claim 5, wherein the electrical circuit further comprises:

a first sensor configured to provide a first signal to the controller through the wire indicative of a first property of the at least one property of the stream of gases;

a first filter in series electrical communication with the first sensor, the first filter configured to pass through to the first sensor a first electrical frequency range driven through the wire, the first electrical frequency range associated with the first signal;

a second sensor configured to provide a second signal to the controller through the wire indicative of a second property of the at least one property of the stream of gases, the second sensor in parallel electrical communication with the first sensor;

a second filter in series electrical communication with the second sensor, the second filter configured to pass through to the second sensor a second electrical frequency range driven through the wire, the second electrical frequency range associated with the second signal; and

a third filter in parallel electrical communication with the first and second filters, the third filter configured to pass through a third frequency range driven through the wire, the third frequency is associated with providing heat to the conduit via the wire.

32. The apparatus of claim 31, wherein the controller comprises:

a first reference resistor in electrical communication with the wire, the first reference resistor associated with the controller determining the first property of the at least one property of the stream of gases;

a fourth filter connected to the wire and configured to pass through to the first reference resistor the first electrical frequency range associated with the first signal;
a second reference resistor in electrical communication with the wire, the second reference resistor associated with the controller determining the second property of the at least one property of the stream of gases; and
a fifth filter connected to the wire and configured to pass through to the second reference resistor the second electrical frequency range associated with the second signal.

33. The apparatus of claim 9, wherein the at least one of the thermistor, the resistor, or the capacitive sensor is positioned in the conduit at or near a radial center of a lumen formed by a wall of the conduit, and wherein the stream of gases is delivered through the lumen.

* * * * *