

(19) World Intellectual Property Organization
International Bureau



(43) International Publication Date
13 November 2008 (13.11.2008)

PCT

(10) International Publication Number
WO 2008/135331 A2

(51) International Patent Classification: **Not classified**

(21) International Application Number:
PCT/EP2008/054171

(22) International Filing Date: 7 April 2008 (07.04.2008)

(25) Filing Language: English

(26) Publication Language: English

(30) Priority Data:
0701086-1 3 May 2007 (03.05.2007) SE

(71) Applicant (for all designated States except US): **TELEFONAKTIEBOLAGET L M ERICSSON (PUBL)**
[SE/SE]; S-164 83 Stockholm (SE).

(72) Inventor; and

(75) Inventor/Applicant (for US only): **BUSIN, Åke** [SE/SE];
Lindvägen 6, S-SE-192 70 Sollentuna (SE).

(74) Agent: **ANDERSSON (LUND), Björn**; P.O. Box 793,
S-SE-220 07 Lund (SE).

(81) Designated States (unless otherwise indicated, for every
kind of national protection available): AE, AG, AL, AM,

AO, AT, AU, AZ, BA, BB, BG, BH, BR, BW, BY, BZ, CA, CH, CN, CO, CR, CU, CZ, DE, DK, DM, DO, DZ, EC, EE, EG, ES, FI, GB, GD, GE, GH, GM, GT, HN, HR, HU, ID, IL, IN, IS, JP, KE, KG, KM, KN, KP, KR, KZ, LA, LC, LK, LR, LS, LT, LU, LY, MA, MD, ME, MG, MK, MN, MW, MX, MY, MZ, NA, NG, NI, NO, NZ, OM, PG, PH, PL, PT, RO, RS, RU, SC, SD, SE, SG, SK, SL, SM, SV, SY, TJ, TM, TN, TR, TT, TZ, UA, UG, US, UZ, VC, VN, ZA, ZM, ZW.

(84) Designated States (unless otherwise indicated, for every kind of regional protection available): ARIPO (BW, GH, GM, KE, LS, MW, MZ, NA, SD, SL, SZ, TZ, UG, ZM, ZW), Eurasian (AM, AZ, BY, KG, KZ, MD, RU, TJ, TM), European (AT, BE, BG, CH, CY, CZ, DE, DK, EE, ES, FI, FR, GB, GR, HR, HU, IE, IS, IT, LT, LU, LV, MC, MT, NL, NO, PL, PT, RO, SE, SI, SK, TR), OAPI (BF, BJ, CF, CG, CI, CM, GA, GN, GQ, GW, ML, MR, NE, SN, TD, TG).

Declarations under Rule 4.17:

- as to applicant's entitlement to apply for and be granted a patent (Rule 4.17(ii))
- of inventorship (Rule 4.17(iv))

Published:

- without international search report and to be republished upon receipt of that report

(54) Title: METHOD AND SYSTEM FOR TRIGGER NEGOTIATION IN SUPL

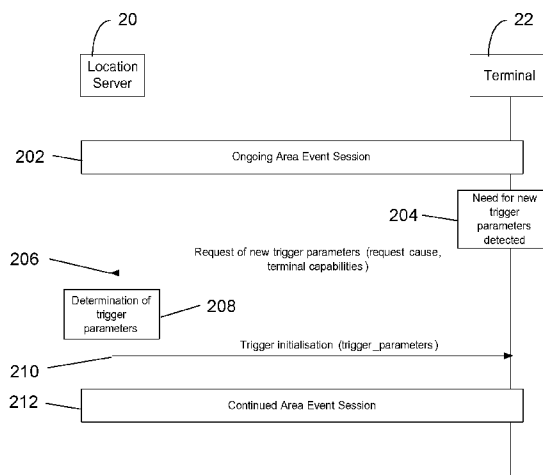

Fig. 2

(57) Abstract: The present invention relates to methods and apparatuses for enabling optimization of trigger parameters related to an area event triggered session between a Secure User Plane Location (SUPL) enabled terminal (SET) (22, 302) and a SUPL supported location server (20, 306). Based on detected changes of terminal conditions (step 204), trigger parameters for the area event trigger are updated (step 208). This allows for a dynamic adoption of the area event triggered parameters to changes of for instance the power status of the terminal or the set of possible positioning methods.

WO 2008/135331 A2

METHOD AND SYSTEM FOR TRIGGER NEGOTIATION IN SUPL

TECHNICAL FIELD

The present invention relates in general to methods and apparatuses for trigger negotiation and in particular to methods and apparatuses for trigger parameter determination in Secure User Plane Location (SUPL).

BACKGROUND

The Secure user plane location (SUPL) is a standardized solution for Assisted Global Positioning System (A-GPS), which is developed by the Open Mobile Alliance (OMA). Whereas other A-GPS systems may be proprietary the OMA standard enables positioning service to be used on any, or close to any, A-GPS capable mobile phone on in practice any mobile network.

The SUPL-based A-GPS system employ a user plane architecture, whereas other A-GPS systems usually are based on a so-called control plane architecture, which would require substantive modifications of the mobile network according to 3GPP location service standards.

Within the user plane architecture a location server, which communicates directly with the mobile device via an IP link, is integrated in the mobile communication network. The core and radio networks may remain the same.

Within mobile positioning systems, whether or not to perform positioning may depend on an area event condition. An area event may be a geographical or a spatial condition that needs to be fulfilled in order to perform a positioning such that the position can be reported to an application, for instance. One example of a geographical condition for a terminal is whether the terminal is inside or outside the geographical area. Triggered

positioning with area event is defined in for instance the Open Mobile Alliance Secure User Plane Location (OMA SUPL) Draft Version 2.0.

5 The so-called trigger parameters, which here can trigger a positioning, may comprise geographical areas, area identities and conditions. It is thus determined whether the terminal is positioned inside a certain geographical area and area identity. The area identities can be any one of network area identities that are broadcast by base stations in cellular networks and Wireless Local Area Networks (W-LAN), such as cell identity (ID) and Location Area Identity. Additionally, trigger parameters may comprise
10 indications of allowed positioning methods, such as the Global Positioning System (GPS).

In OMA SUPL, trigger parameters including any geographical conditions are downloaded from a location server onto the terminal.

15 However, when applying SUPL in the case in which a trigger associated with area identities has been set in the terminal, the terminal first has to determine whether any conditions related to the area identities are fulfilled or not. In the case an area identity condition is fulfilled, the terminal can perform a position determination, for instance by
20 using GPS, such that it can thereafter determine whether any conditions relative to geographical areas are fulfilled, or not.

The mechanism to let the fulfillment of area identity conditions trigger the position determination, is intended to minimize the number of position determinations, as
25 position determination applying GPS typically consumes a significant amount of electric power. If the positioning is frequently performed and/or if the terminal has no external power supply, this may become a problem.

In addition, terminal states other than having low battery power for the terminal may
30 also be populated, such as to detect that the set of possible positioning methods has changed.

Changes in terminal states may risk ending area event sessions between location servers and terminals in SUPL.

- 5 There is hence a need for improving the trigger parameters such that the area event sessions between location servers and terminals can be ensured.

SUMMARY

- 10 An object of the present invention is to provide a possibility to update trigger parameters during on-going area event sessions between location servers and terminals in SUPL.

15 According to an aspect, there is provided a method for providing a trigger parameter request enabling optimization of said trigger parameters related to an area event session involving a portable electronic communication device, the method comprising the steps of detecting a change of at least one condition of the portable electronic communication device, determining that updating of at least one area event related trigger parameter is required, based on the detected change of the at least one condition of the portable
20 electronic communication device, sending a trigger parameter request comprising trigger related portable electronic communication device condition information, and receiving at least one updated trigger parameter, enabling continuation of the area event session based on the received at least one updated trigger parameter.

- 25 Said method for providing a trigger parameter request also may comprise a step of determining a change of the capabilities of the portable electronic communication device in dependence of the detected change of the at least one condition of the portable electronic communication device. The step of determining that updating of the at least one area event trigger parameter is required may also be based on the change of the
30 capabilities of the portable electronic communication device.

The step of detecting a change of the at least one condition within the method for providing a trigger parameter request, may also comprise detecting a change of the power status of the portable electronic communication device.

- 5 The step of detecting a change of the at least one condition within the method for providing a trigger parameter request, may also comprise detecting a change of the set of possible positioning methods for the portable electronic communication device.

According to another aspect, there is provided a portable electronic communication
10 device for providing a trigger parameter request enabling optimization of said trigger parameters related to an area event session involving the portable electronic communication device, where the portable electronic communication device is arranged to be secure user plane enabled, said portable electronic communication device comprising a processing unit, arranged to identify a change of at least one condition of
15 the portable electronic communication device, and arranged to determine that updating of at least one area event related trigger parameter is required, based on the detected change of the at least one condition of the portable electronic communication device, and a transceiving unit, arranged to send a trigger parameter request comprising trigger related portable electronic communication device condition information, and to receive
20 at least one updated trigger parameter, enabling continuation of the area event session based on the received at least one updated trigger parameter.

The processing unit of the portable electronic communication device also may be arranged to determine a change of the capabilities of the portable electronic
25 communication device, in dependence of the detected change of the at least one condition of the portable electronic communication device. The processing unit of the portable electronic communication device also may be arranged to determine that the updating of the at least one area event related trigger parameter being required, is based on the determined change of the capabilities of the portable electronic communication
30 device.

The processing unit of the portable electronic communication device also may be arranged to detect a change of the power status of the portable electronic communication device.

- 5 The processing unit of the portable electronic communication device also may be arranged to detect a change of the set of possible positioning methods for the portable electronic communication device.

The portable electronic communication device may also be a mobile phone.

10

The portable electronic communication device may also be a Secure User Plane Location Enabled Terminal.

15

According to another aspect, there is provided a method for updating trigger parameters enabling optimization of said trigger parameters related to an area event session involving a location server, comprising the steps of receiving a trigger parameter request comprising trigger related portable electronic communication device condition information, determining trigger parameters based on the received trigger related portable electronic communication device condition information, and sending the determined trigger parameters, enabling continuation of the area event session based on the updated trigger parameters.

20

The trigger related portable electronic communication device condition information within the method for updating trigger parameters may also comprise information about a change of the power status of the portable electronic communication device.

25

The trigger related portable electronic communication device condition information within the method for updating trigger parameters may also comprise information about a change of the set of possible positioning methods for the portable electronic communication device.

30

According to yet another aspect, there is provided a location server for updating trigger parameters enabling optimization of said trigger parameters related to an area event session involving the location server, where the location server is arranged to support a
5 secure user plane location platform, comprising a communication unit arranged to receive a trigger parameter request comprising trigger related portable electronic communication device condition information, and arranged to send updated trigger parameters, and a processing unit arranged to update the trigger parameters based on the received trigger related portable electronic communication device condition
10 information, enabling continuation of the area event session based on the updated trigger parameters.

The processing unit of the location server may also be arranged to update the trigger parameters based on information about a change of the capabilities of the portable
15 electronic communication device.

The processing unit of the location server may also be arranged to update the trigger parameters based on information about a change of the set of possible positioning methods for the portable electronic communication device.
20

According to yet another aspect, there is provided a method for enabling optimization of trigger parameters related to an area event session between a portable electronic communication device and a location server, the method comprising the steps of detecting a change of at least one condition of the portable electronic communication device, determining that updating of at least one area event related trigger parameter is
25 required, based on the detected change of the at least one condition of the portable electronic communication device, determining at least one updated trigger parameter based on the trigger related portable electronic communication device condition information, and obtaining at least one updated trigger parameter, enabling continuation
30 of the area event session based on the received at least one updated trigger parameter.

According to still yet another aspect, there is provided a system comprising a portable electronic communication device and a location server, for enabling optimization of trigger parameters related to an area event session between the portable electronic communication device and the location server, wherein the portable electronic communication device is arranged to be secure user plane location enabled, and
5 comprises:

- a processing unit, arranged to identify a change of at least one condition of the portable electronic communication device, and arranged to determine that updating of at least one area event related trigger parameter is
10 required, based on the detected change of the at least one condition of the portable electronic communication device, and
- a transceiving unit, arranged to send a trigger parameter request comprising trigger related portable electronic communication device condition information to the location server, and to receive at least one
15 updated trigger parameter from the location server,

and wherein the location server is arranged to support a secure user plane location platform, and comprises:

- a communication unit arranged to receive a trigger parameter request comprising trigger related portable electronic communication device
20 condition information from the portable electronic communication device, and arranged to send updated trigger parameters to the portable electronic communication device, and
- a processing unit arranged to update the trigger parameters based on the received trigger related portable electronic communication device
25 condition information,

enabling continuation of the area event session based on the updated trigger parameters.

It should be emphasized that the term “comprises/comprising” when being used in the specification is taken to specify the presence of the stated features, integers, steps or
30 components but does not preclude the presence or addition of one or more other features, integers, steps or components or groups thereof.

BRIEF DESCRIPTION OF THE DRAWINGS

In order to explain the invention and the advantages and features thereof in more detail
5 the preferred embodiments will be described below, references being made to the
accompanying drawings, in which

figure 1 is a flow diagram illustrating signal exchange between a location server and
portable electronic communication device for an area event triggered positioning in
10 SUPL of prior art,

figure 2 is a flow diagram illustrating embodiments of method steps, and

figure 3 is a schematic presentation illustrating embodiments of a system comprising a
location server and a portable electronic communication device.

15 DETAILED DESCRIPTION

Figure 1 presents a flow diagram illustrating signal exchange between a location server
102 and terminal 104 for an area event triggered positioning in SUPL, that is
positioning that is triggerable by fulfillment of an area event in SUPL.

20

Within this flow diagram the location server 102 sends SUPL INIT message to the
terminal 104, step A, where the message may comprise information about the trigger
type and the possible positioning methods, to be used by the terminal. In this case the
trigger type for the positioning is area event triggered.

25

The terminal 104 thus receives the SUPL INIT message and performs Data Connection
Setup, step B, where the terminal 104 attaches itself to a packet data network in case the
terminal 104 is not already attached to or alternatively establishes a circuit-switched
data connection.

30

Thereafter the terminal 104 evaluates the message and checks the proxy/non-proxy mode indicator to determine whether the location server 102 uses the proxy or non-proxy mode.

5 The location server may be comprised of a Home SUPL Location Platform (H-SLP). The H-SLP typically comprises a SUPL Location Center (SLC) and may also comprise a SUPL Positioning Center (SPC). The proxy mode refers to the mode where the terminal does not directly communicate with the SPC, but via the SLC that acts as a proxy between the terminal and the SPC.

10

In the non-proxy mode the terminal directly communicates with the SPC.

Now the terminal establishes a secure Internet Protocol (IP) connection to the location server 102 using the address of the location server 102 that is provisioned on the

15

terminal 104 by the home network.

The terminal 104 then sends a SUPL TRIGGERED START message to start a triggered session with the location server 102, step C. This message may comprise parameters such as the location identity (lid) and the capabilities of the SUPL Enabled Terminal 104, the SET capabilities.

20

The location identity (lid) parameter provides cell information to the location server 102. The SET capabilities may comprise the terminal supported positioning methods, such as Radio Resource Location services Protocol (RRLP) in 3GPP, Radio Resource Control (RRC) in 3GPP, TIA-801 etcetera.

25

It can be noted that terminal 104 sends the SUPL TRIGGERED START message even if the suggested positioning method that is comprised in the SUPL INIT message is not comprised in the positioning methods that are supported by the terminal.

30

The location server 102 then selects a positioning method to use for the triggered session by considering the SET capabilities comprised in the SUPL TRIGGERED START message. The location server 102 thereafter sends a SUPL TRIGGERED RESPONSE message to the terminal 104, step D, which message comprises selected
5 positioning method (posmethod) and trigger parameters. After step D the terminal 104 and the location server 102 releases the secure IP connection, as was established above.

The flow may moreover comprise that the terminal 104 performs a check for area id condition to determine whether any conditions are fulfilled or not. In the case where the
10 are identity condition is fulfilled the terminal sends a SUPL POS INIT message to the location server 102, to initiate a positioning session, that is a positioning protocol session in RRLP, RRC or TIA-801, with the location server 102. The SUPL INIT POS message may comprise the location identity (lid). The message may also provide a Network Measurement Report (NMR) specific for a radio technology that is used. For
15 instance, the NMR may comprise Time of Arrival (TA) and/or the GSM received signal level (RXLEV) and may also comprise other measurements for other radio technologies.

The terminal 104 may also provide its position, if available. The terminal 104 may
20 moreover request assistance data by setting up a Requested Assistance data element in SUPL POS INIT message and may then exchange messages with the location server 102 to download the requested assistance data to the terminal 104. This assistance data may be any data that is useful for position determination and may be dependent on the positioning method. The assistance data may comprise Alamanac and Ephemeris data for
25 A-GPS positioning and may comprise other data for other positioning methods. The location server 102 thus receives the SUPL POS INIT message in step F, and determines whether a suitable position estimate is available or not, wherein the suitable position estimate is an estimate that meets the specified quality of position (QoP).

30 If the location server 102 can calculate a suitable position estimate, that is a cell-id based position estimate, based on information comprised in the SUPL POS INIT

message, the location server 102 does not have to establish a positioning session with the terminal 104, but can rather proceed directly to step I, check for area event, where it is determined whether an event trigger condition has been met or not.

5 If the location server can not calculate a suitable position, the location server 102 and the terminal engage in a SUPL POS session and may exchange several successive positioning procedure messages. The location server 102 and the terminal 104 may utilize a SUPL POS message to exchange positioning procedure messages (RRLP/RRC/TIA-801) used to calculate a position estimate for the terminal 104.

10

In a terminal-assisted mode, the terminal may calculate a position estimate based on the positioning measurements received from the terminal 104. For the terminal-based mode, the terminal 104 may calculate a position estimate based on assistance obtained from the location server 102. The terminal 104 may release the secure IP connection to the
15 location server 102 after step G.

If the position estimate is calculated by the location server 102, the location server 102 sends the position estimate in a SUPL REPORT message to the terminal 104, step H.

20 The terminal then compares the position estimate with the area event and determines whether an area event trigger condition has been met or not, step I.

In the case the area event is triggered in step I, the terminal 104 sends a SUPL REPORT message comprising the session ID and the position estimate to the location server 102,
25 step J.

The area event triggered session between the location server 102 and the terminal 104 is thus on-going at this stage. This stage will be returned to down below in connection to the description of one or more of the embodiments as illustrated in figure 2.

30

The location server 102 may subsequently end the area event triggered session by sending a SUPL END message to the terminal 104, step L.

5 In order to enable optimization of trigger parameters the terminal shall be able to indicate that the trigger parameter need to be updated due to changed conditions of the terminal. Examples of changes in terminal conditions may be a change in power status, a change of the set of possible positioning methods, and others.

10 During an on-going trigger session between a location server and a terminal it is indicated in a message that the trigger parameters need to be updated due to changes in conditions relative to the terminal.

15 When determining trigger parameters the location server may not have sufficient information about the terminal to ensure that the trigger parameters are acceptable to the terminal and to user during the entire duration of an area event triggered session. One example is that the power status may change due to the terminal being attached to or detached from an external power supply.

20 This is due to the circumstance that there is currently no means to communicate that the trigger parameters need to be changed because of, for instance, changes in power status.

25 The terminal is enabled to detect that the current trigger parameters no longer are applicable and that new parameters need to be renewed, for example due to that the external power source is applied and unlimited use of GPS is feasible.

Reference will now be given to features and steps in figure 2, showing a flow diagram illustrating a few embodiments of method steps.

30 Figure 2 describes a signal flow between a location server 20 and a portable electronic communication device, such as a mobile phone or a terminal 22. Under step 202, the area event session between the location server and the terminal is on-going. This means

that the estimated position of the terminal meets the area event conditions such that the session between the location server 20 and the terminal 22 is being triggered.

At step 204, the terminal detects that the current trigger parameters need to be updated
5 due to changes in the conditions of the terminal, as mentioned above, such as the battery power has changed, that the set of possible positioning methods has been changed or that access to external power supply has changed, for instance that external power source has been applied, which makes unlimited use of GPS positioning for the terminal 22 feasible.

10

As the terminal 22 detects a change of the conditions of the terminal, the terminal updates its capabilities.

15

Having detected a need for updated trigger parameters, the terminal 22 sends a request for new trigger parameters to the location server 20, step 206. This message may be a SUPL TRIGGERED START message and comprises information about the capabilities of the terminal 22, and information about the cause of the request, and may also
20 comprise information about the session identity and the location identity (lid). This message comprises information that allows the location server 20 to select a new set of trigger parameters, comprising the positioning method to use.

20

It is noted that the request cause is included in the message as sent in step 206. In this case of updated capabilities for the terminal, the request cause is typically that the capabilities of the terminal has been updated.

25

Having received the request of new trigger parameters in step 206, the location server 20 now performs a determination of trigger parameters in step 208. This determination of updated trigger parameters is based on the information as received from the terminal 22 in step 206. The location server 20 may thus determine new trigger parameters at
30 least partly based on the information that the terminal may have access to external power source, which would make unlimited usage of GPS for positioning feasible.

30

During the step of determination of an updated set of trigger parameters, the location server 20 may also conclude that the set of trigger parameters does not need to be changed. This may be due to a large geographical target area and low requirements on
5 the positioning accuracy.

After having determined updated trigger parameters in step 208, the location server 20 sends a trigger initialization message to the terminal 22, in step 210.

10 This trigger initialization message may be a SUPL TRIGGERED RESPONSE message sent from the location server 20 to the terminal 22, which comprises new trigger parameters and may also comprise the session identity, the possible positioning methods and possibly other trigger parameters.

15 This trigger initialization message comprising new trigger parameters is sent in order to ensure that the area events are appropriate for the conditions of the terminal. In the case some parameters are unchanged, various encodings to indicate this can be used.

The sending of the trigger initialization message in step 210, to the terminal 20 enables
20 the terminal to continue the area event triggered session with the location server 20, in step 212.

An embodiment in line with the flow in the flow diagram as illustrated in figure 2 may be implemented as an extension of an existing flow where the terminal may request a
25 new Area Identity list for the reason that it has attached to a new Public Land and Mobile Network (PLMN).

Figure 3 schematically illustrates embodiments of a system for optimization of trigger parameters related to an area event session between a portable electronic
30 communication device 302 such as a terminal or a mobile phone, and a location server 306.

Figure 3 further presents a communication network 304 linking the terminal 302 to the location server 306. The communication network 304 provides communication for the terminal 302 and could comprise base stations (Node Bs) and network controllers.

5

However, in order to simplify figure 3, the terminal 302 only comprises a transceiving unit 308 and a processing unit 310, the communication network only comprises a transceiving unit 312, a processing unit 314, and a communication unit 316 and the location server only comprises a processing unit 318 and a communication unit 320.

10

Needless to say, each entity may comprise any number of processors, memory units, transceiving units or transceivers, communication units, controllers etc.

15

The terminal or the portable electronic communication device 302 is typically arranged to be secure user plane location enabled, and comprises a processing unit 310 that is arranged to identify a change of at least one condition of the portable electronic communication device. One example of such a change is a change of the power status of the portable electronic communication device, caused for instance by a change of the battery power, or that an access to external power supply has changed, either that the external power supply has been connected to the portable electronic communication device or that a connection between the power supply and the device or terminal has been terminated. Another example of a change of at least one condition is a change of the possible positioning methods for the terminal.

20

25

The processing unit 310 may further be arranged to determine a change of the capabilities of the portable electronic communication device, based on the detected change of at least one condition of the portable electronic communication device. The processing unit may also be arranged to determine that based on the determined change of the capabilities of the portable electronic communication device, updating at least one area event related trigger parameter is required.

30

The transceiving unit 308 is typically arranged to send a trigger parameter request comprising trigger related portable electronic communication device condition information, to the location server 306, via the communication network 304. The trigger related portable electronic communication device condition information typically
5 comprises updated information about the capabilities of the portable electronic communication device or terminal, so that a change of the capabilities can be forwarded to the location server 306.

The trigger parameter request sent to the location server 306 may be a SUPL
10 TRIGGERED START message, comprising information about the updated capabilities of the portable electronic communication device 302.

The trigger parameter request is firstly received by the transceiving unit 312 of the communication network 304, wherein it may be processed by the processing unit 314,
15 and forwarded to the communication unit 316 of the communication network 304. The communication unit 316 then forwards the trigger parameter request comprising trigger related portable electronic communication device condition information to the communication unit 320 of the location server 306, which communication unit 320 is arranged to receive the trigger parameter request comprising the trigger related portable
20 electronic communication device condition information. The communication unit 320 may then forward the request to the processing unit 318.

The processing unit 318 is typically arranged to update the trigger parameters based on the received trigger related portable electronic communication device condition
25 information, as a response to the trigger parameter request. The processing unit 318 may update the trigger parameters based on information about a change of the power status of the portable electronic communication device 302. It may also update the trigger parameters based on information about a change of the set of possible positioning methods for the portable electronic communication device 302.

30

Having determined a new set of trigger parameters, this is then forwarded to the communication unit 320 within the location server 306. The communication unit 320 then sends a trigger initialization message such as a SUPL TRIGGERED RESPONSE message to the communication unit 316 of the communication network 304. This message comprises the new set of trigger parameters and may also comprise session identity, the possible positioning methods. This message is then forwarded to the processing unit 314 and the transceiving unit 312 of the communication network 304. From the transceiving unit 312 the trigger initialization message is then communicated to the transceiving unit 308 of the terminal or the portable electronic communication device 302. The transceiving unit 308 then forwards the updated set of trigger parameters to the processing unit 310.

Having received the new set of trigger parameters, the processing unit 310 may then determine whether an area event trigger condition has been met or not, enabling a continuation of any on-going area event sessions.

It is emphasized that the present invention can be varied in many ways, of which the alternative embodiments as presented are just a few examples. These different embodiments are hence non-limiting examples. The scope of the present invention, however, is only limited by the subsequently following claims.

The embodiments come with a few advantages of which one is that a terminal can request an updated set of trigger parameters related to an area event session, such that an on-going session can be dynamically adopted to conditions such as battery running out of capacity or that external power supply is attached or detached. This is clearly advantageous since power consumption is a major concern when implementing GPS positioning in mobile terminals and especially for triggered positioning where the GPS positioning may be used frequently.

Another advantage is that the adaptation optimizes the user experience in relation to available power.

CLAIMS

1. A method for providing a trigger parameter request enabling optimization of trigger parameters related to an area event session between a portable
5 electronic communication device (302) and a location server (306), the method comprising the steps of:
- detecting a change of at least one condition of the portable electronic communication device (step 204),
 - determining that updating of at least one area event related trigger
10 parameter is required (step 204), based on the detected change of the at least one condition of the portable electronic communication device,
 - sending a trigger parameter request (step 206) comprising trigger related portable electronic communication device condition information, and
 - receiving at least one updated trigger parameter (step 210),
- 15 enabling continuation of the area event session based on the received at least one updated trigger parameter.
2. The method for providing a trigger parameter request according to claim 1, further comprising a step of determining a change of the capabilities (step 204)
20 of the portable electronic communication device (302), in dependence of the detected change of the at least one condition of the portable electronic communication device, and wherein the step of determining that updating of the at least one area event trigger parameter is required, is based on the change of the capabilities of the portable electronic communication device.
- 25
3. The method for providing a trigger parameter request according to claim 1 or 2, wherein the step of detecting a change of the at least one condition (step 204) comprises detecting a change of the power status of the portable electronic communication device (302).
- 30

4. The method for providing a trigger parameter request according to any one of claims 1-3, wherein the step of detecting a change of the at least one condition (step 204) comprises detecting a change of the set of possible positioning methods for the portable electronic communication device (302).
- 5
5. A portable electronic communication device (302) for providing a trigger parameter request enabling optimization of trigger parameters related to an area event session involving the portable electronic communication device, where the portable electronic communication device is arranged to be secure user plane location enabled, said portable electronic communication device comprising:
- 10
- a processing unit (310), arranged to identify a change of at least one condition of the portable electronic communication device, and arranged to determine that updating of at least one area event related trigger parameter is required, based on the detected change of the at least one condition of the portable electronic communication device, and
 - 15
 - a transceiving unit (308), arranged to send a trigger parameter request comprising trigger related portable electronic communication device condition information, and to receive at least one updated trigger
 - 20
 - parameter,
 - enabling continuation of the area event session based on the received at least one updated trigger parameter.
- 25
6. The portable electronic communication device (22, 302) according to claim 5, wherein the processing unit (310) further is arranged to determine a change of the capabilities of the portable electronic communication device, in dependence of the detected change of the at least one condition of the portable electronic communication device and arranged to determine that updating of the at least one area event related trigger parameter is required, is based on the determined
- 30
- change of the capabilities of the portable electronic communication device.

7. The portable electronic communication device (22, 302) according to claim 5 or 6, wherein the processing unit (310) further is arranged to detect a change of the power status of the portable electronic communication device.
- 5 8. The portable electronic communication device (22, 302) according to any one of claims 5-7, wherein the processing unit (310) further is arranged to detect a change of the set of possible positioning methods for the portable electronic communication device.
- 10 9. The portable electronic communication device (22, 302) according to any one of claims 5-8, wherein the portable electronic communication device is a mobile phone.
- 15 10. The portable electronic communication device (22, 302) according to any one of claims 5-9, wherein the portable electronic communication device is a Secure User Plane Location Enabled Terminal (SET).
- 20 11. A method for updating trigger parameters enabling optimization of said trigger parameters related to an area event session involving a location server (20, 306), comprising the steps of:
- receiving a trigger parameter request (step 206) comprising trigger related portable electronic communication device (22, 302) condition information,
 - determining trigger parameters (step 208) based on the received trigger related portable electronic communication device condition information,
 - 25 and
 - sending the determined trigger parameters (step 210), enabling continuation of the area event session based on the updated trigger parameters.
- 30 12. The method for updating trigger parameters according to claim 11, wherein the trigger related portable electronic communication device (22, 302) condition

information comprises information about a change of the capabilities of the portable electronic communication device.

- 5 13. The method for updating trigger parameters according to claim 11 or 12, wherein the trigger related portable electronic communication device (22, 302) condition information comprises information about a change of the set of possible positioning methods for the portable electronic communication device.
- 10 14. A location server (20, 306) for updating trigger parameters enabling optimization of said trigger parameters related to an area event session involving the location server, where the location server is arranged to support a secure user plane location platform, comprising:
- 15 - a communication unit (326) arranged to receive a trigger parameter request comprising trigger related portable electronic communication device condition information, and arranged to send updated trigger parameters, and
 - a processing unit (318) arranged to update the trigger parameters based on the received trigger related portable electronic communication device (22, 302) condition information,
- 20 enabling continuation of the area event session based on the updated trigger parameters.
- 25 15. The location server (20, 306) according to claim 14, wherein the processing unit (318) further is arranged to update the trigger parameters based on information about a change of the power status of the portable electronic communication device (22, 302).
- 30 16. The location server (20, 306) according to claim 14 or 15, wherein the processing unit (318) further is arranged to update the trigger parameters based on information about a change of the set of possible positioning methods for the portable electronic communication device (22, 302).

17. A method for enabling optimization of trigger parameters related to an area event session between a portable electronic communication device (22, 302) and a location server (306), the method comprising the steps of:
- 5 - detecting a change of at least one condition (step 204) of the portable electronic communication device (22, 302),
 - determining that updating of at least one area event related trigger parameter is required (step 204), based on the detected change of the at least one condition of the portable electronic communication device (22, 10 302),
 - determining at least one updated trigger parameter (step 208) based on the trigger related portable electronic communication device condition information, and
 - obtaining at least one updated trigger parameter (step 210),
- 15 enabling continuation of the area event session based on the received at least one updated trigger parameter.
18. A system for enabling optimization of trigger parameters related to an area event session involving a portable electronic communication device and a 20 location server, the system comprising the portable electronic communication device (22, 302) according to any one of claims 5-10, and the location server (20, 306) according to any one of claims 14-16.
- 25

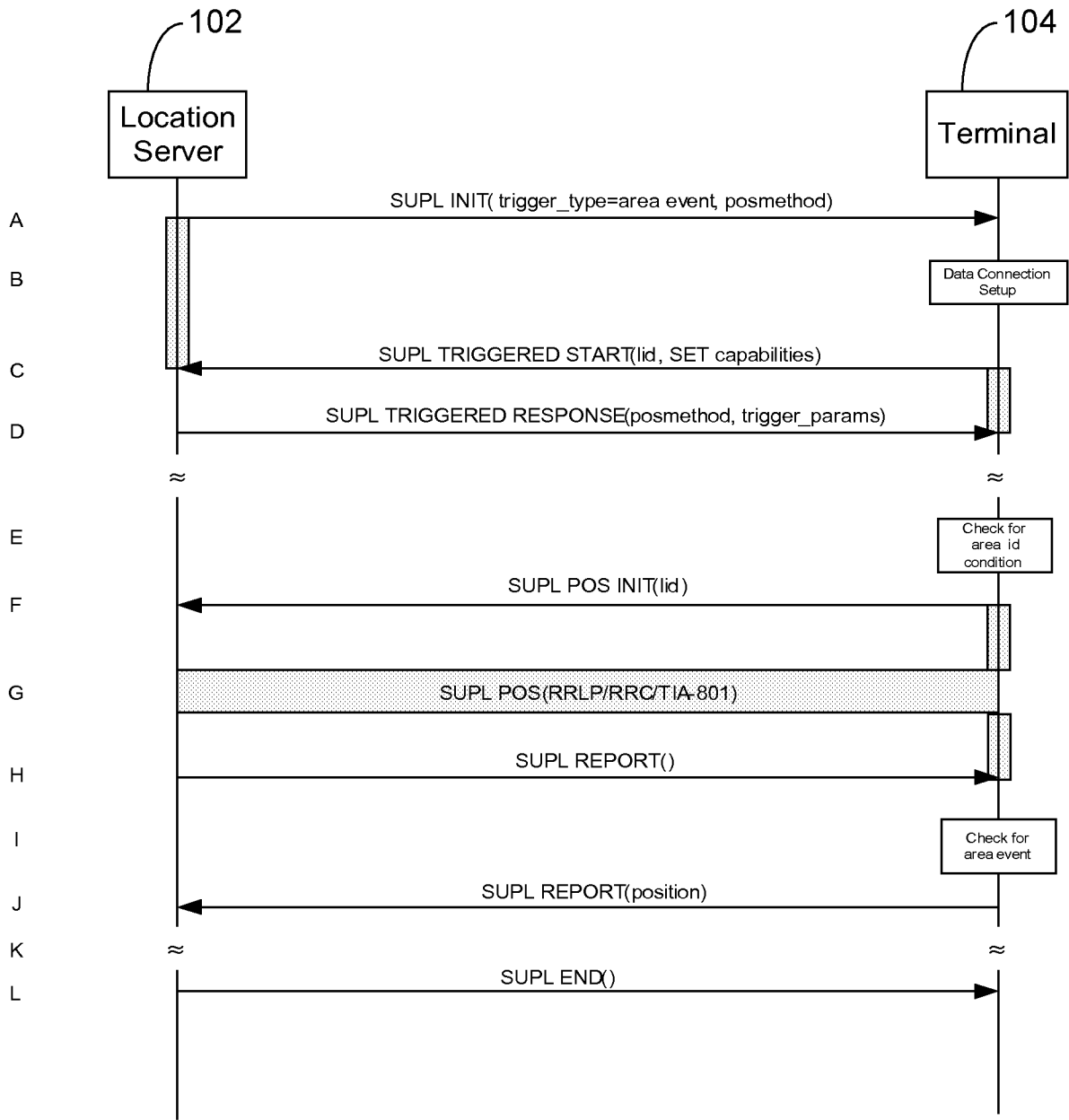

Fig. 1

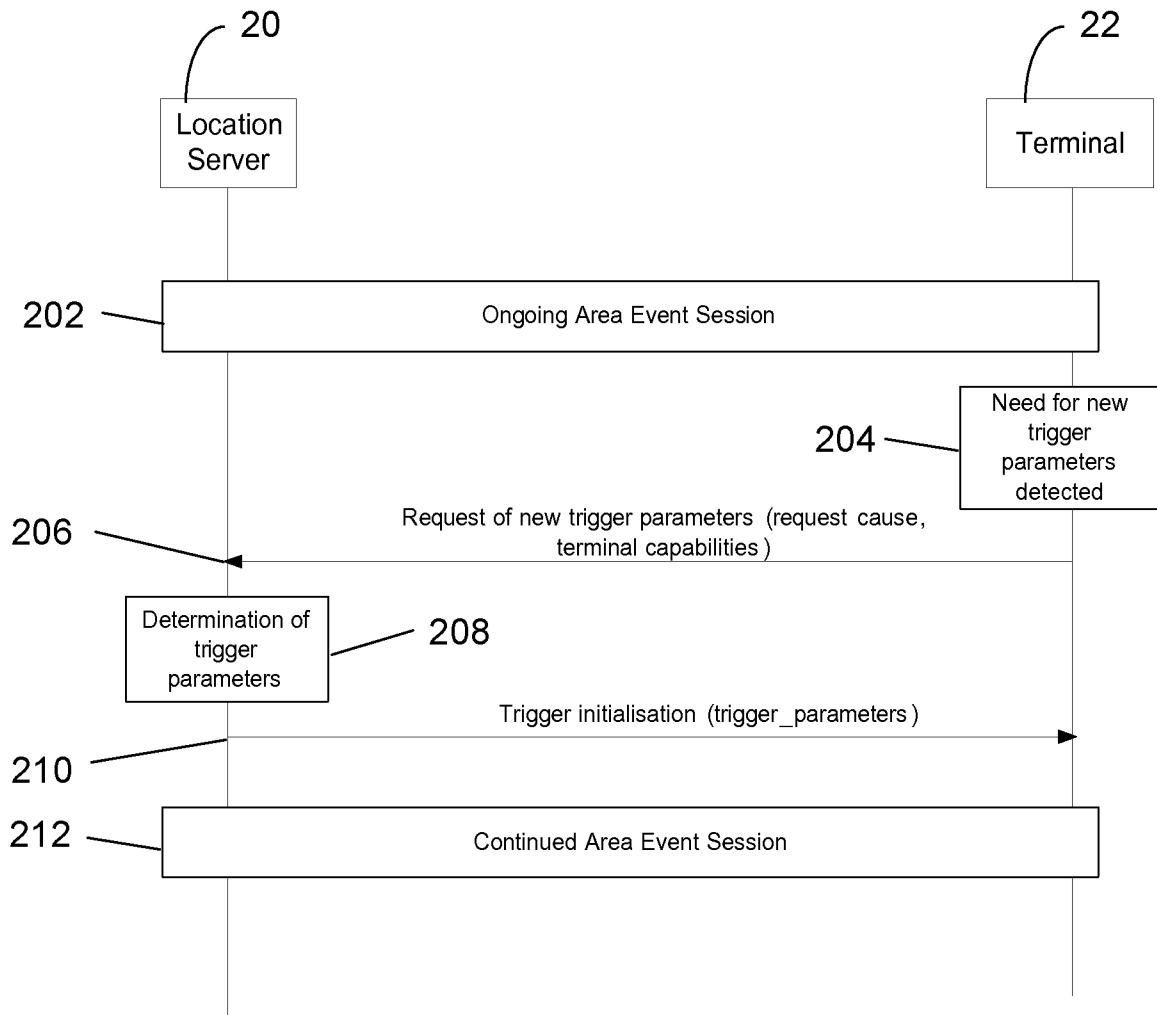

Fig. 2

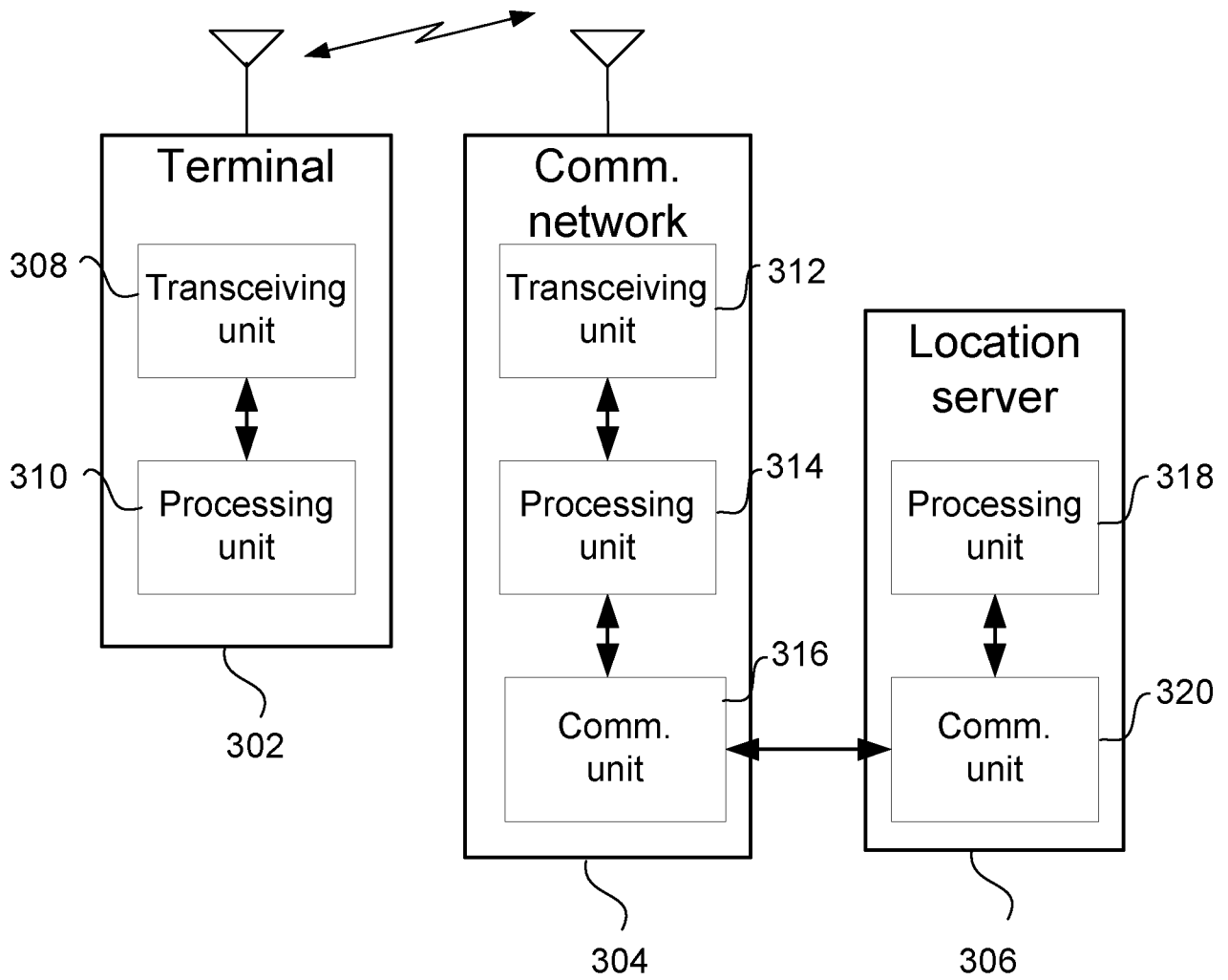

Fig. 3