



US00D604226S

(12) **United States Design Patent**
Scheuren

(10) **Patent No.:** **US D604,226 S**

(45) **Date of Patent:** **** Nov. 17, 2009**

(54) **TIRE**

(75) Inventor: **Daniel Scheuren**, Arlon (BE)

(73) Assignee: **The Good Year Tire & Rubber Company**, Akron, OH (US)

(**) Term: **14 Years**

(21) Appl. No.: **29/335,985**

(22) Filed: **Apr. 27, 2009**

(51) **LOC (9) Cl.** **12-15**

(52) **U.S. Cl.** **D12/553**

(58) **Field of Classification Search** D12/533,
D12/567, 900-901; 152/209.1, 209.8-209.19,
152/209.25, 209.28, 455

See application file for complete search history.

(56) **References Cited**

U.S. PATENT DOCUMENTS

D385,234 S *	10/1997	Young	D12/553
D423,419 S *	4/2000	Kemp et al.	D12/553
D448,709 S	10/2001	Le	D12/147
D457,855 S	5/2002	Bawin et al.	D12/582
D458,580 S	6/2002	Young et al.	D12/512
D473,843 S	4/2003	Le et al.	D12/594
D489,036 S *	4/2004	Irimiya	D12/553
D497,875 S	11/2004	Le et al.	D12/594
D500,288 S	12/2004	Maziarka et al.	D12/601
D506,722 S *	6/2005	Nonaka	D12/553
D517,468 S	3/2006	Le et al.	D12/594
D528,500 S	9/2006	Le et al.	D12/600
D533,498 S	12/2006	Scheuren et al.	D12/588
D534,858 S	1/2007	Le et al.	D12/553
D554,055 S	10/2007	Beauguitte et al.	D12/600
D555,078 S *	11/2007	Radulescu et al.	D12/553

D584,679 S * 1/2009 Radulescu D12/553
D586,730 S * 2/2009 Scheuren et al. D12/553

* cited by examiner

Primary Examiner—Stacia Cadmus

(74) *Attorney, Agent, or Firm*—Richard B. O’Planick

(57) **CLAIM**

The ornamental design for a tire, as shown and described.

DESCRIPTION

FIG. 1 is a perspective view of a tire showing my new design, it being understood that the pattern repeats uniformly throughout the circumference of the tread;

FIG. 2 is a front elevational view thereof;

FIG. 3 is a right side elevational view thereof, the opposite side elevational view being identical thereto;

FIG. 4 is an enlarged fragmentary front elevational view thereof;

FIG. 5 is a perspective view of a second embodiment of a tire showing my new design, it being understood that the pattern repeats uniformly throughout the circumference of the tread and that the opposite side perspective view is identical thereto; and,

FIG. 6 is a front elevational view of a second embodiment, it being understood that an enlarged fragmentary view thereof would be substantially identical to that shown in FIG. 4, with the exception of the inclusion of the sidewall in solid lines.

In the drawings, the broken lines showing of the sidewall, inner bead and the peripheral boundary between the tire tread and the sidewall in FIGS. 1 through 4 depict environmental subject matter and form no part of the claimed design.

1 Claim, 6 Drawing Sheets

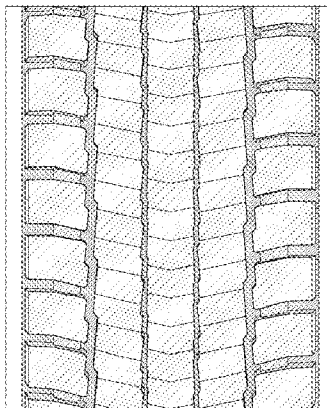
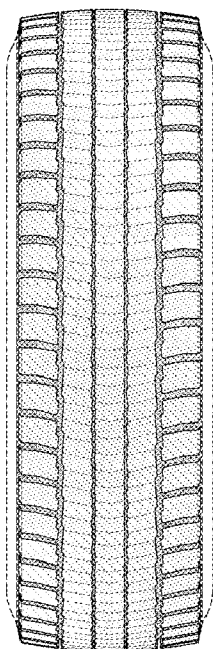

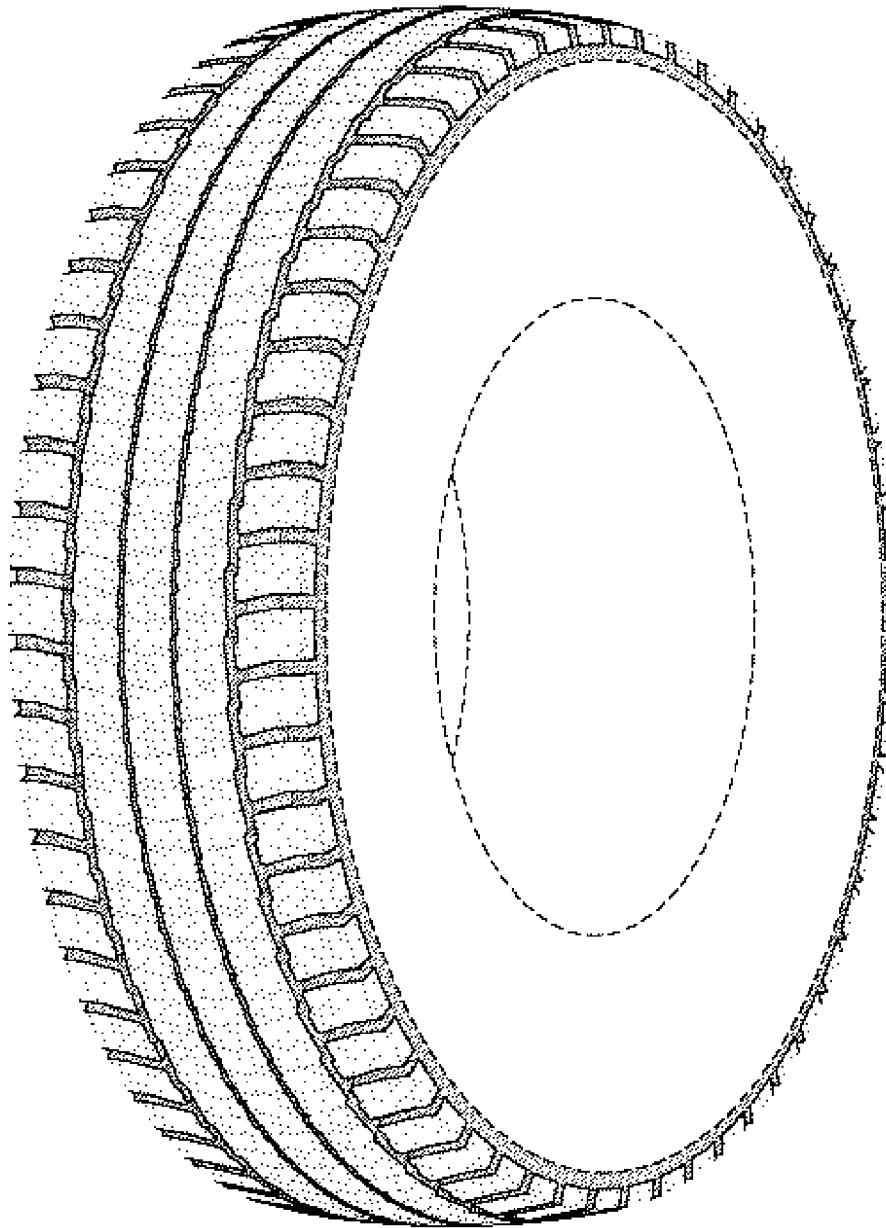

FIG-1

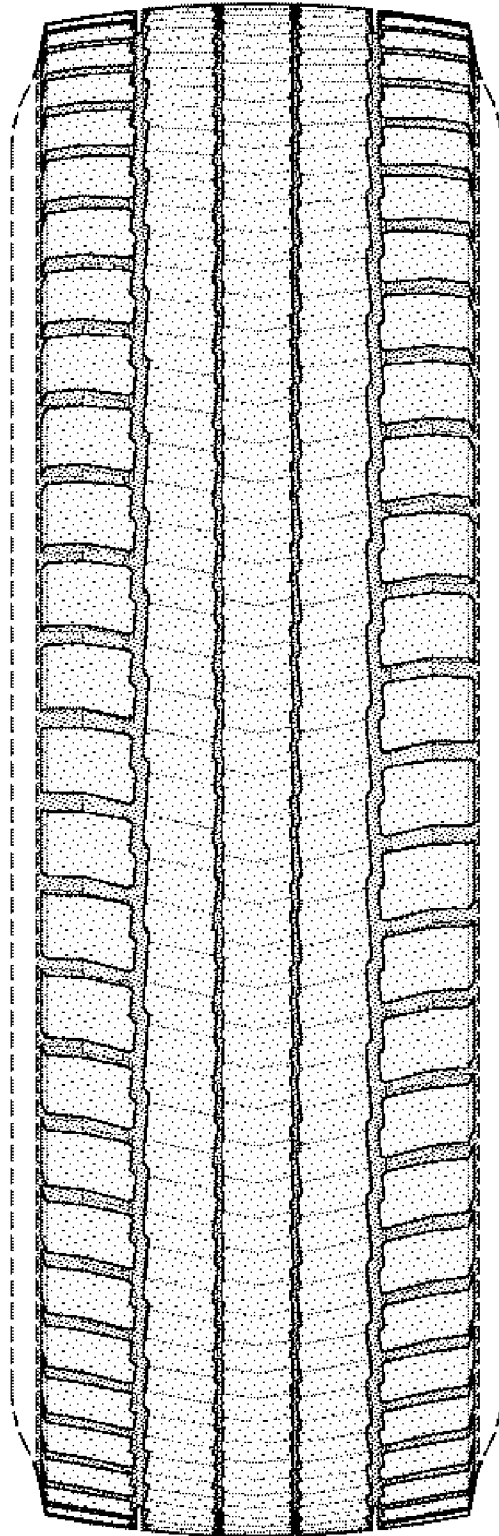

FIG-2

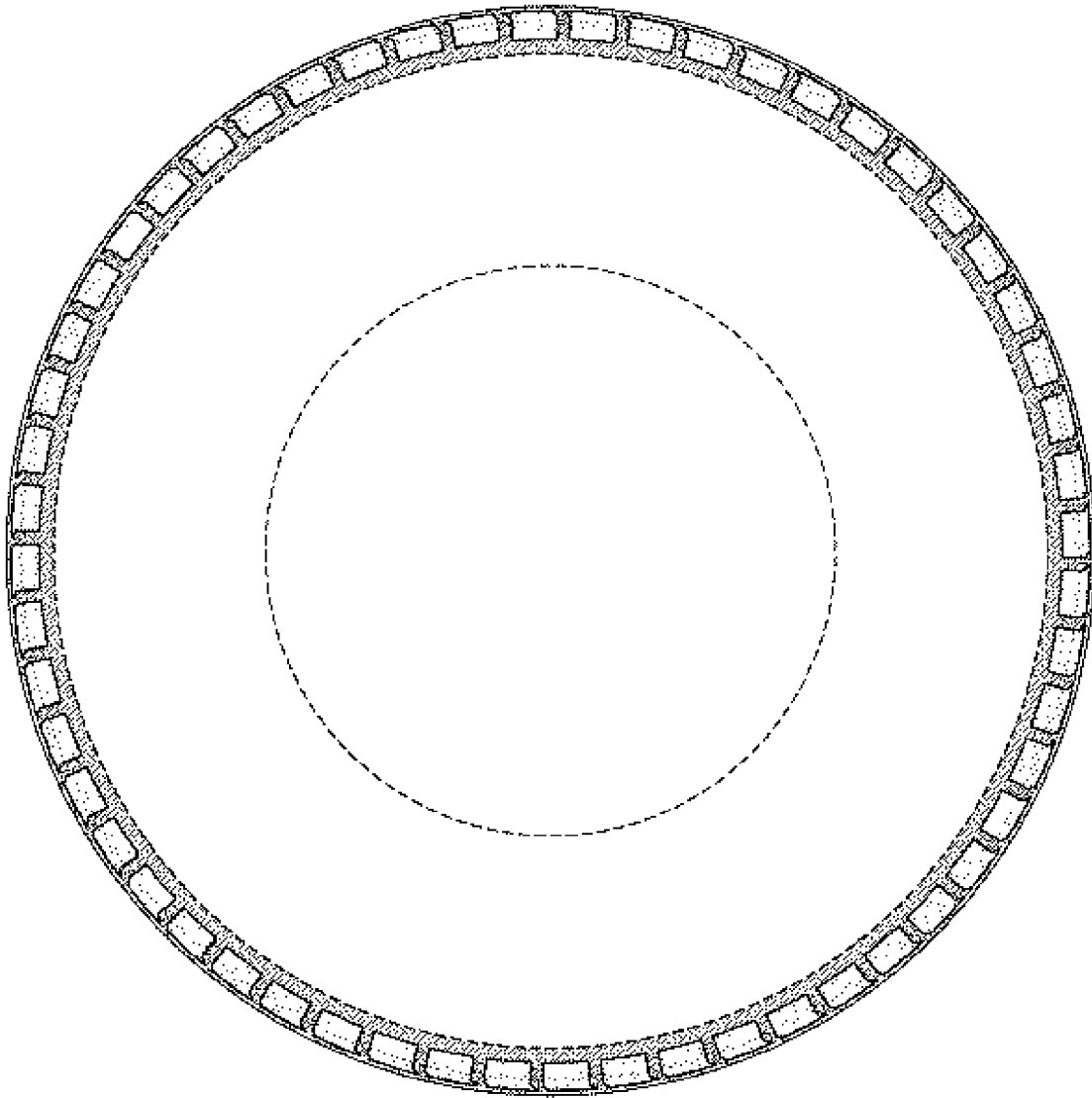

FIG-3

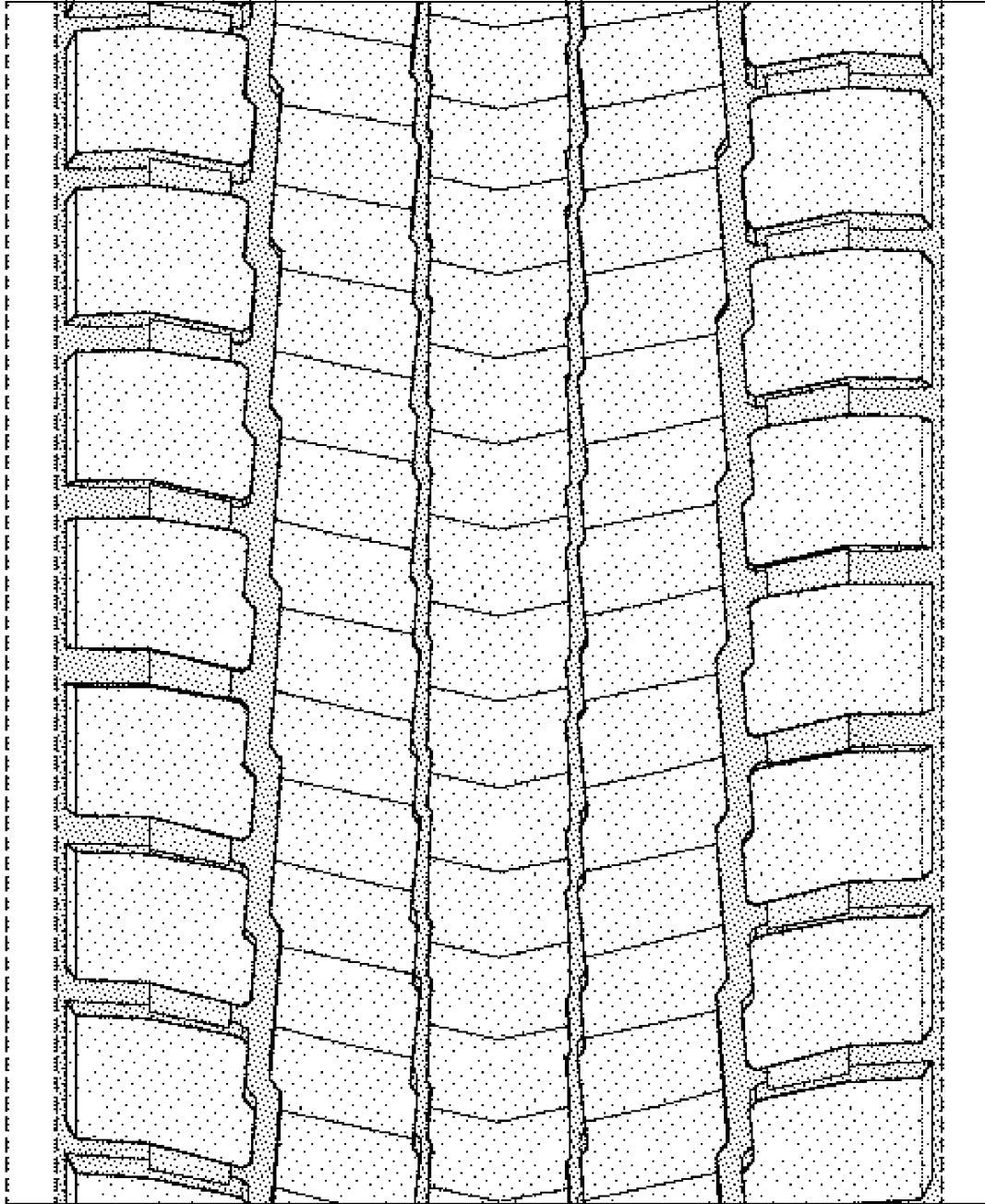

FIG-4

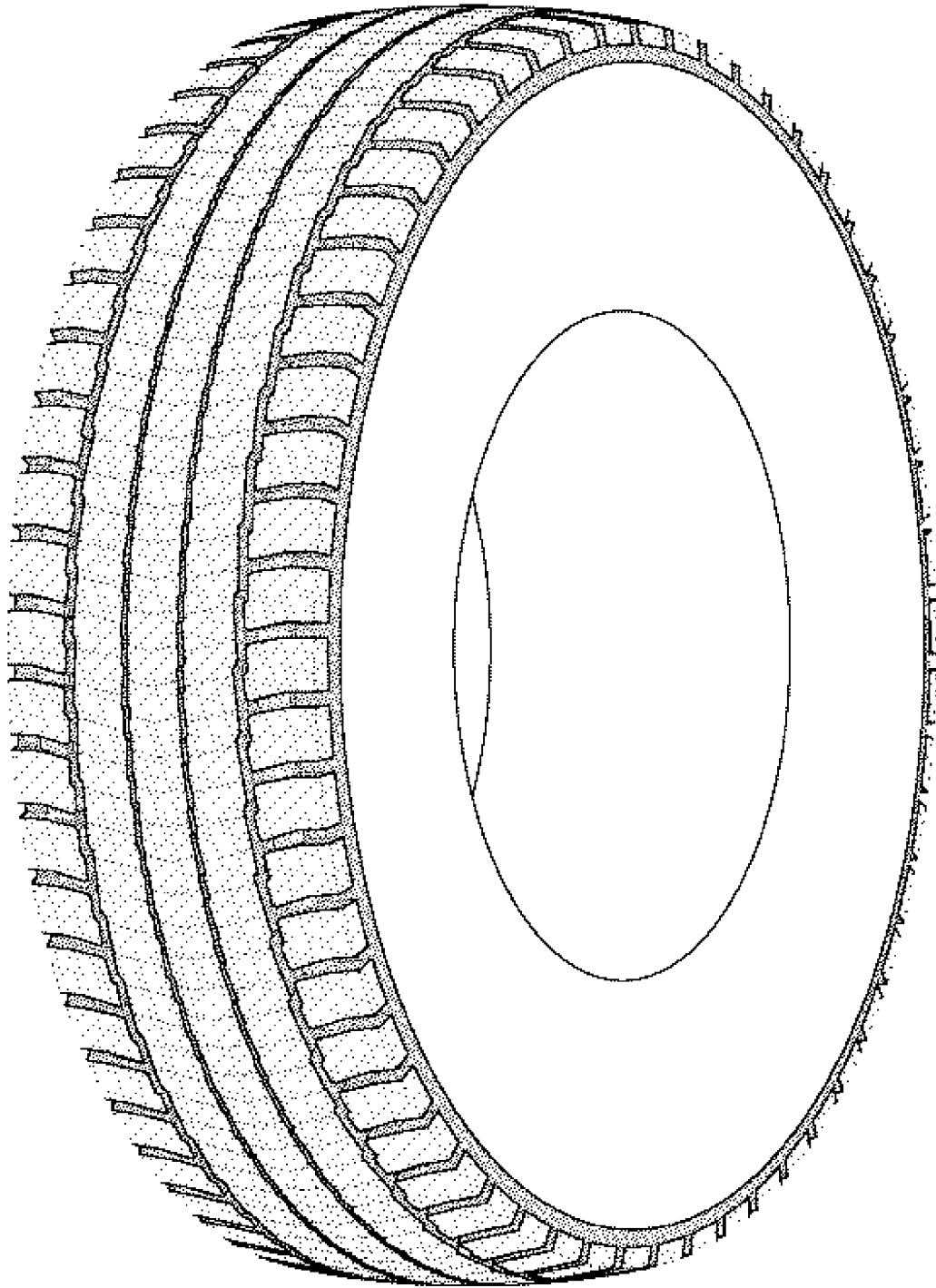

FIG-5

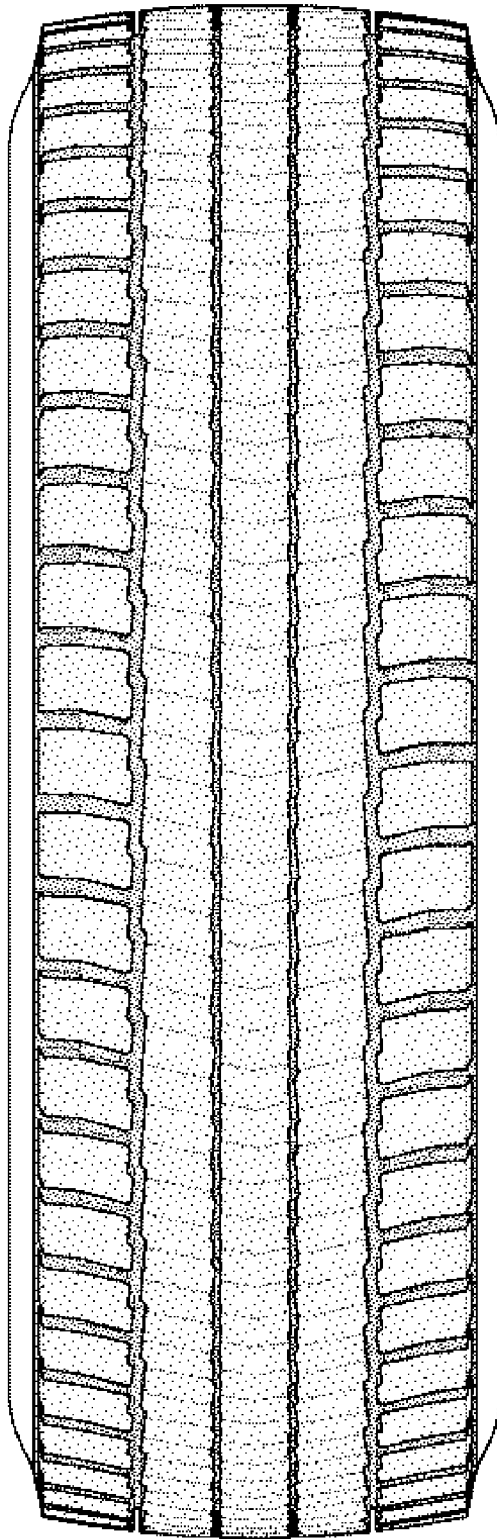

FIG-6