

(19)



(11)

**EP 2 074 921 A2**

(12)

**EUROPEAN PATENT APPLICATION**

(43) Date of publication:  
**01.07.2009 Bulletin 2009/27**

(51) Int Cl.:  
**A47L 15/42<sup>(2006.01)</sup> D06F 39/10<sup>(2006.01)</sup>**

(21) Application number: **09154971.7**

(22) Date of filing: **08.01.2003**

(84) Designated Contracting States:  
**DE ES FR GB IT SE**

- **Heil, Michael**  
**21025, Comerio (IT)**
- **Fierling, Yannick**  
**21025, Comerio (IT)**

(30) Priority: **28.02.2002 DE 10208992**

(62) Document number(s) of the earlier application(s) in accordance with Art. 76 EPC:  
**03000076.4 / 1 340 448**

(74) Representative: **Guerci, Alessandro**  
**Whirlpool Europe S.r.l.**  
**Patent Department**  
**Viale G. Borghi 27**  
**21025 Comerio (VA) (IT)**

(71) Applicant: **Whirlpool Corporation**  
**Benton Harbor, MI 49022 (US)**

(72) Inventors:  
• **Kunkel, Jochen**  
**21025, Comerio (IT)**

Remarks:  
This application was filed on 12-03-2009 as a divisional application to the application mentioned under INID code 62.

(54) **A screen filter for a liquid-conducting device, in particular a dishwashing machine**

(57) Household dishwashing machine with a screen filter (10) that is designed relatively flat with flow holes (17), separating the washing space from a drainage shaft and lying at the bottom of the washing space, sealing the perimeter. The screen fiber (10) is designed and manu-

factured as a plastic-injection mould part provided with an edge (14/18) that protrudes vertically on the underside (13) as a sealing lip; in doing so a screen filter (10) is created that can be manufactured cost-effectively provides an optimal sealing effect at the edge (14/18) and largely excludes the influence of material fatigue.

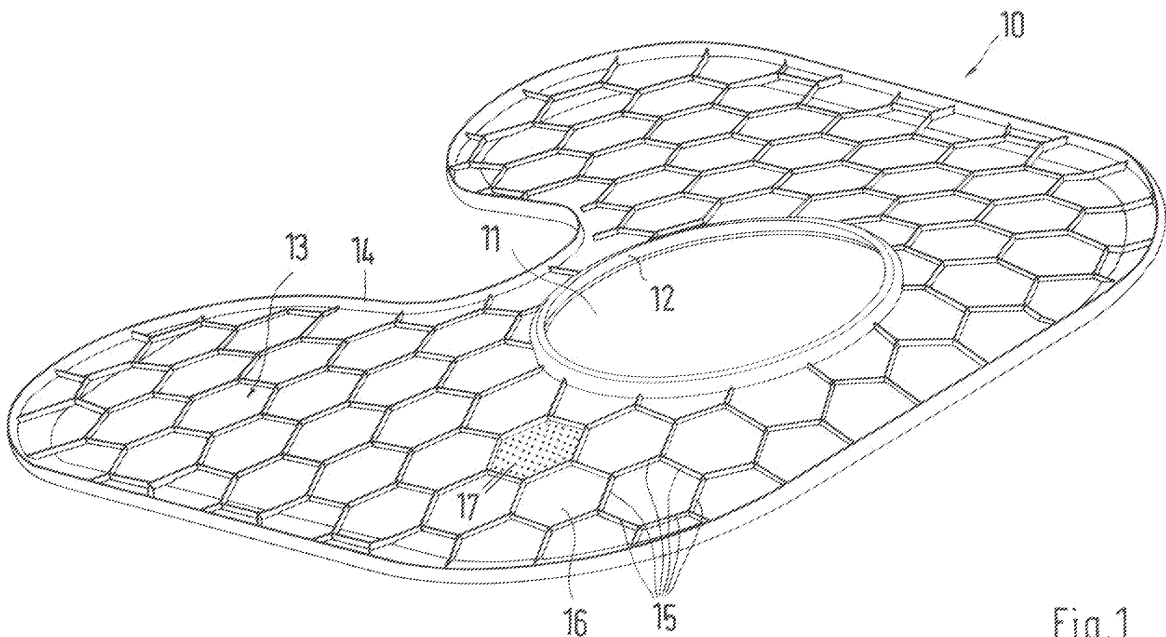

Fig.1

**EP 2 074 921 A2**

## Description

**[0001]** The present invention relates to a household dishwashing machine having a screen filter with flow holes, separating the washing space from a drainage shaft and lying at the bottom of the washing space, sealing the perimeter.

**[0002]** Such a dishwashing machine is disclosed in US-A-5700329. Such document discloses a relatively flat screen type filter for a dishwasher made of metallic material, provided with legs to link the filter with other portions of the dishwasher. GB-A-1530206 discloses a flat screen filter for dishwashers made in a single piece of plastic molded material. The screen filter removes entrained solid particles from the liquid when draining the liquid from the washing space by passing it through the holes. They are held back by the screen filter and do not end up in the drainage shaft. The solid particles can be taken out when removing the screen filter and disposed of when cleaning the screen filter.

**[0003]** Filter screens of this type are usually designed as flexible metal punch-hole components that on the one hand can not optimally be designed in terms of flow restriction, i.e. the entire flow surface, and on the other hand cannot effectively seal the edges due to production reasons. The result is that often small solid particles cannot sufficiently be retained and end up in the drainage shaft.

**[0004]** The task of the invention is to create a screen filter of the type mentioned at the outset that can be manufactured easily and cost efficiently and that is optimized in terms of flow restriction and the entire flow surface, provides an optimal sealing effect at the edges and that largely excludes the influence of material fatigue due to its design.

**[0005]** This requirement is solved by the invention thanks to the features listed in the appended claims.

**[0006]** The edge lining of the screen filter around the drainage shaft is improved and sealed in that a link web that protrudes vertically on the underside is designed as a sealing lip.

**[0007]** The seal can be improved even more by providing the edge area with a double web that protrudes vertically on the underside that is designed as a double sealing lip or that is provided at the edge with an edging that protrudes out on the bottom side that is provided with receptacles for attaching an elastic sealing element.

**[0008]** According to another preferred feature of the invention, the screen filter is equipped with flow holes that flare out in the flow direction, which are condensed to individual honeycombs in staggered row formation, that at the exterior of the edge it is provided with an orbiting, vertically aligned web that seals and is flat or linear shape, that it provides stiffening, injected reinforcement links in partitions on its underside, and the flow holes can be selected very small such that even the smallest of solid particles are retained. The number of flow holes can be selected very large to achieve a large overall flow area

while simultaneously retaining very small solid particles. At the same time, reinforcement links on the bottom of the screen filter provide the screen filter with sufficient stability and stiffness even in thin screen filters. This also achieves long, device-specific lifetimes for screen filters manufactured in this way.

**[0009]** The intended design of the screen filter is that it adopts a thickness of approx. 1 to 1.2 mm and that the diameter of the flow holes is approx. 1 mm and a distance of approx. 2 mm between adjacent rows. It is intended furthermore that adjacent rows of flow holes are each offset opposite to each other by half the distance between rows and the imaginary connection lines of the midpoint of three directly adjacent flow holes form an isosceles triangle, thus the entire flow surface can be optimized to the maximum by the honeycombs, which are separated by reinforcement links.

**[0010]** The design of the reinforcement links provides for a thickness of between 0.5 to 0.8 mm and a height of approx. 2 mm.

**[0011]** In one design, optimal use of screen filter surface space is achieved in that the reinforcement links arranged on the bottom separate individual, normally constructed, hexagonal honeycombs fields, which are furnished with "2 N -1" rows of flow holes, wherein "N" is the number of holes at the edges of the honeycombs. The design provides rows of holes at the honeycomb edge with "n" flow holes and rows of holes with "2 N -1" flow holes in the middle of the honeycombs field.

**[0012]** Draining the liquid from which solid particles have been removed can be improved in that the profile of the flow holes flares out towards the underside, preferably designed as truncated cones.

**[0013]** The invention is described in more detail using the example embodiments shown in the attached drawings in which:

Fig. 1, is a perspective view of the underside of a screen filter for a dishwashing machine according to the invention,  
 Fig. 2, is a partial view of the bottom side of a hexagonal field of the screen filter of Figure 1,  
 Fig. 3, is a sectional view along the line III-III of the field of Figure 2,  
 Fig. 4, is a sectional view along the line IV-IV of the field of Figure 2,  
 Fig. 5 to Fig. 7 show three designs for the vertically aligned edge links of Fig. 1, and  
 Fig. 8 shows the arrangement and design of the honeycomb-shape designed flow holes.

**[0014]** The design of the screen filter 10 shown in Fig. 1 is typical for a dishwashing machine. The opening 11 embedded in the screen filter 10 normally surrounds a coarse filter that is set in the drainage shaft, wherein the edge 12, which sticks up on the underside 13 of the

screen filter 10 accepts the fit after sealing. The edge 14 that encompasses the circumference of the screen filter 10 also protrudes on the underside 13 and serves the same purpose, as will be shown below.

**[0015]** The screen filter 10, which is designed and manufactured as a plastic-injection mould part is relatively thin with a material thickness of approx. 1 to 1.2 mm and can therefore be produced with low material cost. In order for the entire surface of the screen filter 10 to maintain sufficient stability, reinforcement links 15 that stick up are injected on the underside 13 next to the edges 12 and 14 that have a thickness of between 0.5 mm and 0.8 mm and a height of approx. 2 mm and separate the fields 16. These fields 16 are designed for optimal use of space as standard hexagons that border each other in a honeycomb shape and cover the vast majority of the surface space of the screen filter 10. These fields 16 are provided with rows of flow holes 17, the arrangement of which will be shown as an example.

**[0016]** In order to attain the greatest flow passage within a honeycomb, the holes are arranged as shown in Fig. 8. Flow passage is optimized in that the flow holes are arranged in the shape of an isosceles triangle. The distance "d1" equals the length of the sides. The distances "d1" and "d2" are contingent upon the minimal wall thicknesses. In order to achieve maximum flow passage the screen is designed with two distances "d1" and "d2"; "d1" defines the hole spacing within a honeycomb and "d2" the minimum hole spacing between the outer holes of two bordering honeycombs (see Fig. 8).

**[0017]** Figure 2 shows such a surface 16 of the screen filter 10 in the view of its underside 13. Reinforcement links 15 encompass the surface 16 and the adjacent surfaces 16 link up without surface loss. The flow holes 17 have a diameter of approx. 1 mm and are arranged in rows, wherein they provide a distance of approx. 2 mm in the rows. In the example embodiment thirteen rows are provided that begin and end with seven flow holes on the edges of the field 6 and increase to thirteen flow holes 17 in the middle, as shown in the sectional views of Fig. 3 and 4. Since the adjacent rows of flow holes 17 are always offset to each other by half the distance, the distance of the rows is kept small and the surface of the field 16 can be used optimally for a large flow surface, however keep the surface of flow holes 17 very small in order to retain small solid particles as well.

**[0018]** The flow holes 17 may continually increase in profile from the topside to the underside 13 of the screen filter 10 in order to improve the flow of liquid that has been freed of solid particles. A truncated cone-like design of the flow holes 17 has proven to be particularly beneficial.

**[0019]** The edge 14 of the screen filter 10 is designed, in a first embodiment of the invention, as a sealing lip which forms the transition from the screen filter 10 to the base 20 of the water conducting space, in order to seal the drainage shaft, as shown in Fig. 5. According to a second embodiment of the invention, the edge is designed as a double sealing lip, as Fig. 6 illustrates.

**[0020]** Finally, the edge 14 also provides receptacles 19 that allow for the attachment or injection of a separate, elastic sealing element 30, as shown in Fig. 7.

## Claims

1. A household dishwashing machine having a screen filter (10) with flow holes (17), which separates the washing space from a drainage shaft and lies at the bottom of the washing space, sealing the perimeter, **characterized in that** the screen filter (10) is designed and manufactured as a plastic-injection mould part and it is provided with an the edge (14, 18) that protrudes vertically on the underside (13) as a sealing lip.
2. A household dishwashing machine according to claim 1, **characterized in that** the edge presents a double web (18) protruding vertically on the underside (13) as a double seal lip.
3. A household dishwashing machine according to claim 1 or 2, **characterized in that** the edge (14, 18) that protrudes vertically on the underside (13) is provided with receptacles (19) for mounting an elastic sealing element (30).
4. A household dishwashing machine according to any of the preceding claims, **characterized in that** the screen filter (10) is provided with defined bearing surfaces that guarantee a favorable flow contact with retainers and also provide a positive form fit at the edge even after material fatigue has set in.
5. A household dishwashing machine according to any of the preceding claims, **characterized in that** the screen filter (10) on its underside (13) is divided at least in partitions by means of injected reinforcement links (15) in fields (16) with flow holes (17) that are arranged in rows.
6. A household dishwashing machine according to any of the preceding claims, **characterized in that** the reinforcement links (15) are designed as regular hexagons separating the fields (16) with rows of flow holes (17).
7. A household dishwashing machine according to any of the preceding claims, **characterized in that** the rows of the flow holes (17) of the screen filter (10), which are at the edges of the field (16), are provided with N flow holes and in the middle of the field (16) with 2N-1 flow holes (17).

8. A household dishwashing machine according to any of the preceding claims,  
**characterized in that** the reinforcement links (15) of the screen filter (10) have a thickness between 0.5 to 0.8 mm and a height of approx. 2 mm. 5
9. A household dishwashing machine according to any of the preceding claims,  
**characterized in that** the profiles of the flow holes (17) grow continually larger in the direction of the underside (13), preferably designed truncated cone-shaped. 10

15

20

25

30

35

40

45

50

55

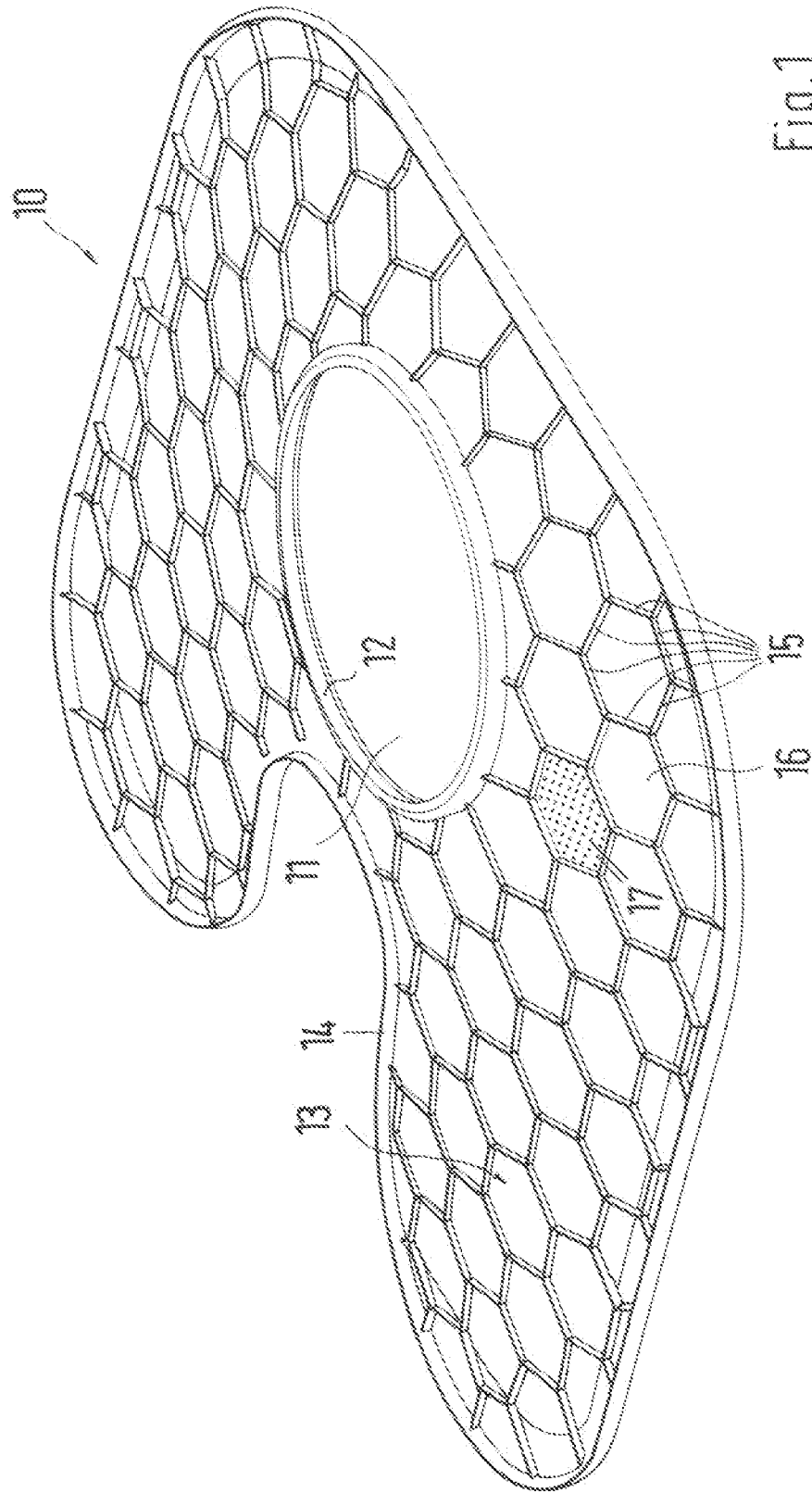

Fig.1

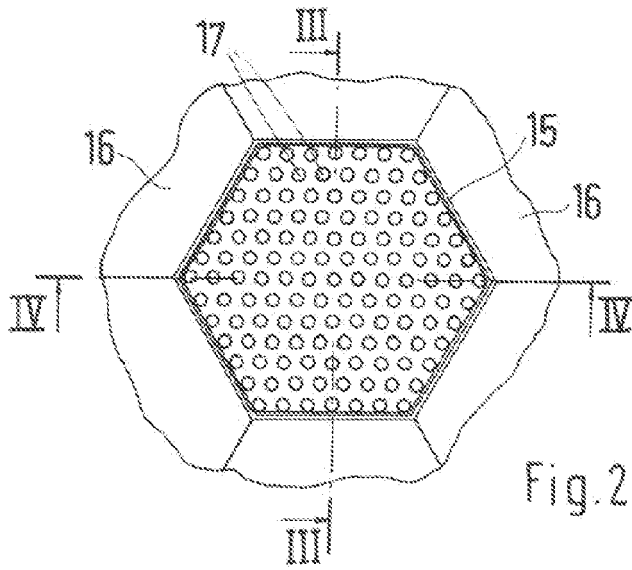

Fig. 2

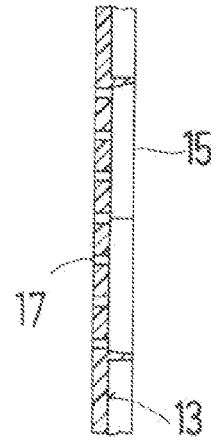

Fig. 3

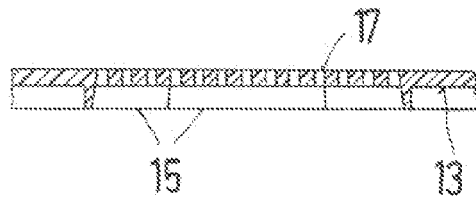

Fig. 4

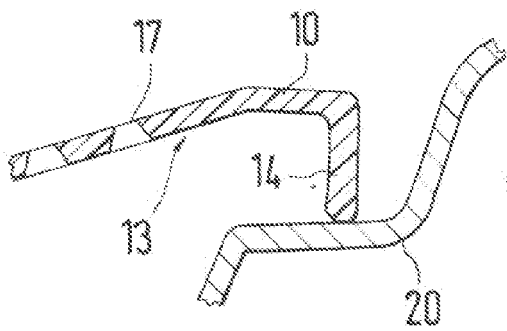

Fig. 5

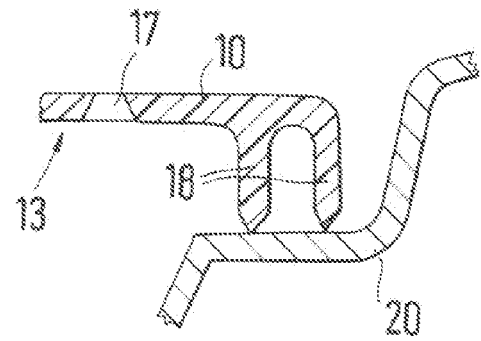

Fig. 6

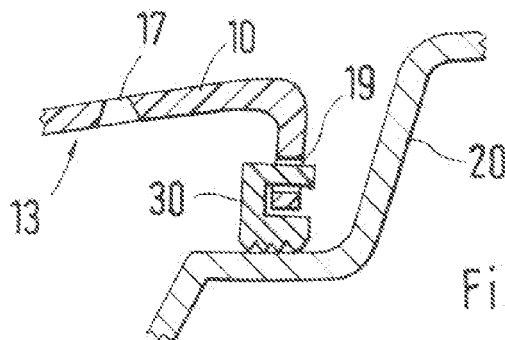

Fig. 7

Figure 8



**REFERENCES CITED IN THE DESCRIPTION**

*This list of references cited by the applicant is for the reader's convenience only. It does not form part of the European patent document. Even though great care has been taken in compiling the references, errors or omissions cannot be excluded and the EPO disclaims all liability in this regard.*

**Patent documents cited in the description**

- US 5700329 A [0002]
- GB 1530206 A [0002]