

(No Model.)

2 Sheets—Sheet 1.

W. O. WORTH.
GOVERNOR FOR STEAM ENGINES.

No. 434,575.

Patented Aug. 19, 1890.

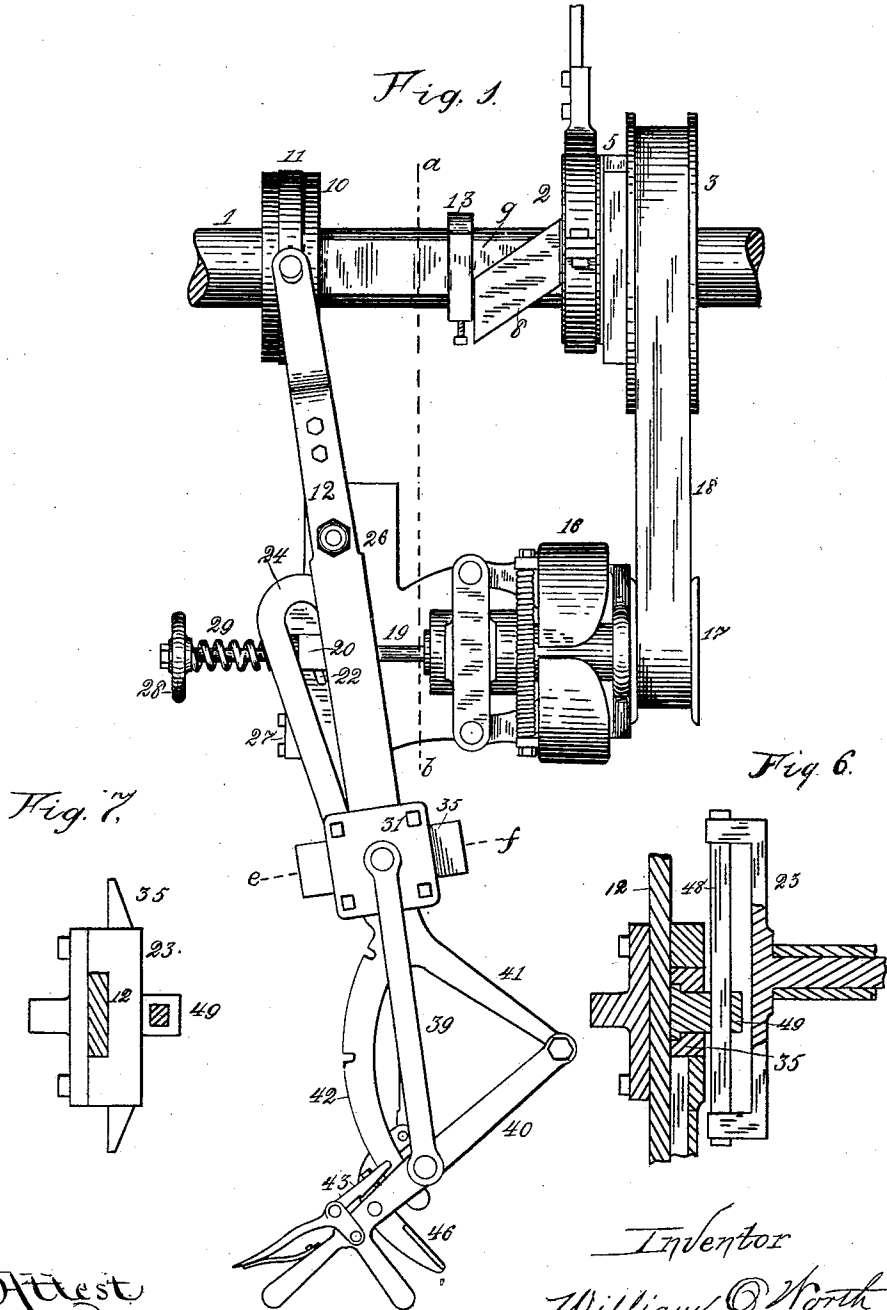

Attest
A. K. Jones.
S. M. Brainerd.

Inventor
William O. Worth
By J. M. St. John
Atty.

(No Model.)

2 Sheets—Sheet 2.

W. O. WORTH.
GOVERNOR FOR STEAM ENGINES.

No. 434,575.

Patented Aug. 19, 1890.

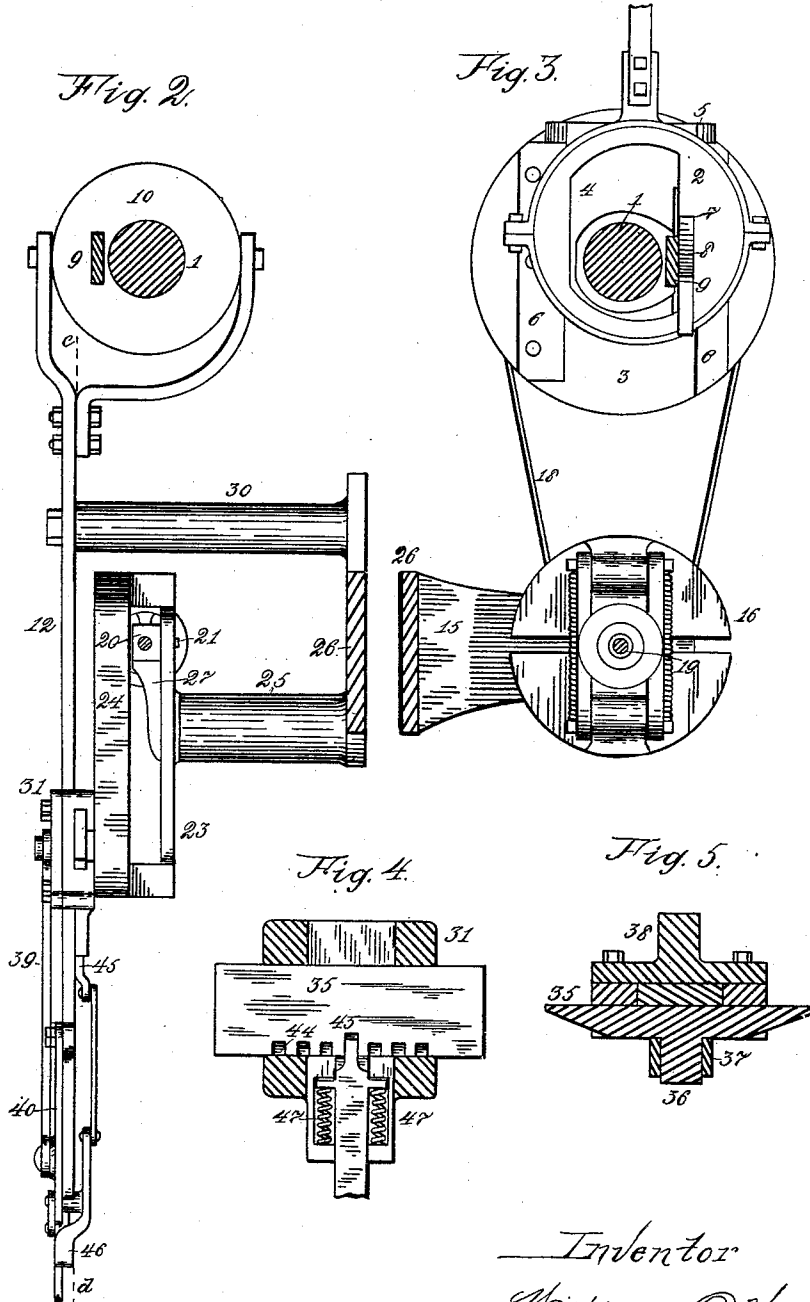

Attest.
A. K. Jones.
S. M. Drainerd.

Inventor
William O. Worth.
By J. M. St. John
Atty.

UNITED STATES PATENT OFFICE.

WILLIAM O. WORTH, OF CEDAR RAPIDS, IOWA.

GOVERNOR FOR STEAM-ENGINES.

SPECIFICATION forming part of Letters Patent No. 434,575, dated August 19, 1890.

Application filed February 10, 1890. Serial No. 339,872. (No model.)

To all whom it may concern:

Be it known that I, WILLIAM O. WORTH, a citizen of the United States, residing at Cedar Rapids, in the county of Linn and State of Iowa, have invented certain new and useful Improvements in Governors for Steam-Engines; and I do hereby declare the following to be a full, clear, and exact description of the invention, such as will enable others skilled in the art to which it appertains to make and use the same.

This invention relates to governors for steam-engines, more particularly road-engines; and the object of the invention is to provide for the perfect control of steam for the purpose of regulating the speed of the engine and for the convenient reversing of said engine.

The invention consists in the construction, combination, and arrangement of parts, as hereinafter fully set forth and claimed.

In the accompanying drawings, forming a part of this specification, Figure 1, Sheet 1, is a plan view of a device embodying my invention. Fig. 2, Sheet 2, is an elevation of the left side of the same as viewed from the section-line *a b* in Fig. 1. Fig. 3 is a similar view of the right side of said Fig. 1. Fig. 4 is a horizontal section of the link-block on the line *c d* of Fig. 2. Fig. 5 is a vertical section of the same on the line *ef* of Fig. 1. Fig. 6, Sheet 1, is a central longitudinal section of a modified form of link and connections; and Fig. 7, an end view of the same.

Similar figures of reference indicate corresponding parts.

The governor embodied in my invention, while applicable to many other types of steam-engines, is particularly applicable to road-engines. In the practical operation of such engines it is of course necessary to reverse the engine for the purpose of backing the same. It is also desirable to change the relative speed of the same on the road from that employed in work. Thus in passing over a heavy piece of road the engine should be adjusted to run more slowly than on smooth hard road. So, also, in approaching a steep grade it is desirable to increase the speed of the engine and "make a run" for the grade. These objects I attain in the governor which I will now describe.

Referring to the drawings, 1 is the crank-shaft of the engine, on which is mounted an eccentric 2, movably attached to a belt-wheel 3. This eccentric is provided with a slot 4, permitting it to travel across the shaft, and on the side adjacent to the belt-wheel has a cross-head 5, sliding between the ways 6, secured to said belt-wheel.

To provide for the proper lead and lap, the slot 4 is a little to one side of the center, as represented in Fig. 3. In one side of this slot is formed a recess 7, running diagonally across the eccentric and adapted to receive the diagonal slide 8, forming a part of the sliding bar 9, connected with a collar 10, mounted on the crank-shaft. This collar is provided with a suitable sleeve 11, connecting pivotally with a vertical lever 12 and adapted to be shifted thereby. A collar 13, mounted on the shaft and having a suitable slot 14 through it to admit the bar 9, serves to steady said bar as thrust endwise, and also serves as a stop for the diagonal slide 8 at its extreme outward position.

On a suitable standard 15 is mounted horizontally a governor 16, which is of an ordinary type and need not be particularly described. The shaft of the governor is provided with a suitable sheave 17, which communicates by a belt 18 with the belt-wheel 3. The stem 19 of this governor passes through a block 20, having a stud 21 engaging with a slot 22 in the bottom piece 23 of a link 24. This bottom piece is pivoted to the post 25, attached to the same base 26 as the standard 15. On the outer side of this post is secured a plate 27. Between this plate, through the end of which the governor-stem passes, and the hand-wheel 28, mounted on the threaded end of the governor-stem, is placed a spring 29, adapted to counteract the centrifugal action of the governor-balls.

On the base 26 is a post 30, forming a pivotal support for the lever 12. This lever passes through a link-block 31, connecting by its outwardly-extending stud 32 with the link 24, and adapted to slide on said lever and in said link. This link-block is of peculiar construction, as illustrated in Figs. 4 and 5, being provided with a central slot 33 to permit its movement on the lever 12, and a transverse slot or groove 34, on which is

mounted a T-head 35, the downwardly-extending stud of which 36, provided with a traveler 37, forms the connection of the link-block with the link. On the upper side of the link-block is a stud 38, connecting the block by a suitable rod 39 with a hand-lever 40. This hand-lever is pivoted at the extremity of an arm 41, forming a part of the lever 12, and opposite thereto is a notch - quadrant 42, adapted to secure the hand-lever in various positions by means of the latch 43.

In the side of the T-head 25 toward the hand-lever are notches 44, which engage with the end of a latch 45, connecting by its stem with a hand-lever 46, pivotally secured to the lever 40. The latch is held into engagement with the said notches by means of springs 47.

The operation of the device will now be understood. The revolution of the crank-shaft causes the usual centrifugal action of the governor-balls, which, connecting with the stem of the governor 19, tends to draw the block 20 and therewith the connected link toward said balls, this action being suitably compensated for by the spring 29. Through the action of the link, which is pivoted near the center, with the lever 12 the lateral movement of said link is communicated to the collar 10, and thence by means of the slide 8 to the eccentric 2, thus automatically regulating the flow of steam to the necessities of the engine. To reverse the engine, it is but necessary to throw the hand-lever to the position opposite to that shown in Fig. 1, when the relative position of all the parts is correspondingly shifted. The operation of the link and its connections is now practically the same as in the former case. By means of the T-head a further adjustment of the governor is secured. Now by disengaging the latch 45 the link-block 31 may be shifted on the T-head to any desired position by throwing the outer end of the lever 12 bodily in either direction. This, as will be evident, shifts the relative position of the collar 10 on the shaft, and in the same degree the corresponding position of the slide 8 and the connected eccentric, thereby changing the speed of the engine. To reverse the engine by means of this device, the link-block is moved to a central position with respect to the link and shifted in the same manner.

A modified form of link is shown in Fig. 6. In this construction the upper part of the link is a single rod 48, passing through a stud 49, pivoted in the T-head 35.

What I now claim is—

1. In a governor for steam-engines, the combination, with the governor, substantially as described, of an eccentric adapted to move across the shaft, a diagonal slide engaging with said eccentric and by intermediate mechanism with a pivoted lever, a pivoted link and a link-block engaging with said link and adapted to slide on said lever, with means, substantially as described, for adjusting the relative position of the said link-block.

2. The combination, with the governor, substantially as described, of a pivoted link and block engaging therewith and adapted to slide therein, and also with a pivoted lever on which it is adapted to slide, a hand-lever connecting with said pivoted lever adapted to shift said link-block, a diagonal slide 8, engaging with the opposite end of said pivoted lever and also with an eccentric which is adapted to shift across the shaft, substantially as described, whereby the flow of steam is automatically regulated and the engine may be reversed.

3. The combination, with the stem 19 of a governor, of the block 20, having stud 21, link 24, having slot 22, with which said stud engages, the plate 27, spring 29, and adjustable hand-wheel 28, all substantially as and for the purpose set forth.

4. The combination, with the collar 10 and connected mechanism for shifting the eccentric 2, of a pivoted lever 12, a pivoted link 24, longitudinal sliding link-block 31, engaging with the link and lever, hand-lever 40, connecting-rod 39 and block 20, connecting with the stem 19 of the governor, substantially as and for the purpose set forth.

5. The combination, with the collar or sleeve 10, and connected mechanism adapted to shift an eccentric 2, of a pivoted lever 12, a pivoted link 24, and a link-block 31, adapted to shift longitudinally with respect to said link and said lever and also transversely with respect to said lever, substantially as set forth.

6. In a governor, the combination, with the lever 12 and link 24, of the herein-described link-block 31, having a slot through it to admit of its sliding endwise on said lever, and a groove across it in which is mounted a T-head 35, the stud 37 of which forms a connection with the link, whereby the link-block is adapted to be shifted longitudinally and laterally with respect to the lever 12, substantially as and for the purpose set forth.

7. The combination, with the link 24, lever 12, and link-block 31, of the T-head 35, having notches 44 therein, the latch 45, engaging with said notches, and a suitable hand-lever 46, for shifting the same, substantially as set forth.

8. The combination, with the link 24, adapted to engage with a governor, substantially as described, pivoted lever 12, link-block 31, and its connected T-head 35, of the hand-lever 40, adapted to shift said link-block longitudinally, and the hand-lever 46, connected with said hand-lever 40, and the latch 45, whereby the block is adapted to be shifted laterally on said lever 12, substantially as and for the purpose set forth.

9. In a governor, the combination, with the lever 12 and link-block 31, adapted to slide thereon, of the T-head 35, pivoted stud 49, and link 24, having a single guide-rod 48, passing through said stud.

10. In a governor, the combination, with the link-block 31, having the notched T-head 35, of the lever 40, having thereon the latch 43 and

5 the independent hand-lever 46, the lever connecting with the link-block by a connecting-rod 39 and the hand-lever 46 to a latch engaging the notches in the T-head by a connecting-rod, substantially as set forth.

11. The combination, with connected actuating mechanism, substantially as described, of the eccentric 2, having cross-head 5, the belt-wheel 3, having ways 6, the slide 8, adapt-

ed to shift said eccentric across the shaft, 10 and the governor 16, having sheave 17, substantially as and for the purpose set forth.

In testimony whereof I affix my signature in presence of two witnesses.

WILLIAM O. WORTH.

Witnesses:

W. H. MEYERS,
S. W. BRAINERD.