

(19) World Intellectual Property Organization
International Bureau



(43) International Publication Date
7 December 2000 (07.12.2000)

PCT

(10) International Publication Number
WO 00/74406 A1

- (51) International Patent Classification⁷: **H04Q 7/22, G07C 9/00**
- (21) International Application Number: PCT/SE00/01084
- (22) International Filing Date: 26 May 2000 (26.05.2000)
- (25) Filing Language: Swedish
- (26) Publication Language: English
- (30) Priority Data:
9901891-3 26 May 1999 (26.05.1999) SE
9902469-7 29 June 1999 (29.06.1999) SE
- (71) Applicant and
(72) Inventor: **DUHS, Henry** [SE/SE]; Ängsvägen 23, S-181 41 Lidingö (SE).
- (74) Agents: **BERGLUND, Stefan** et al.; Bjerkéns Patentbyrå KB, Östermalmsgatan 58, S-114 50 Stockholm (SE).
- (81) Designated States (*national*): AE, AL, AM, AT, AU, AZ, BA, BB, BG, BR, BY, CA, CH, CN, CR, CU, CZ, CZ (utility model), DE, DE (utility model), DK, DK (utility model), DM, EE, EE (utility model), ES, FI, FI (utility model), GB, GD, GE, GH, GM, HR, HU, ID, IL, IN, IS, JP, KE, KG, KP, KR, KZ, LC, LK, LR, LS, LT, LU, LV, MA, MD, MG, MK, MN, MW, MX, NO, NZ, PL, PT, RO, RU, SD, SE, SG, SI, SK, SK (utility model), SL, TJ, TM, TR, TT, TZ, UA, UG, US, UZ, VN, YU, ZA, ZW.
- (84) Designated States (*regional*): ARIPO patent (GH, GM, KE, LS, MW, MZ, SD, SL, SZ, TZ, UG, ZW), Eurasian patent (AM, AZ, BY, KG, KZ, MD, RU, TJ, TM), European patent (AT, BE, CH, CY, DE, DK, ES, FI, FR, GB, GR, IE, IT, LU, MC, NL, PT, SE), OAPI patent (BF, BJ, CF, CG, CI, CM, GA, GN, GW, ML, MR, NE, SN, TD, TG).
- Published: — With international search report.

[Continued on next page]

(54) Title: MOBILE COMMUNICATION UNIT COMPRISING A RFID-CIRCUIT FOR EXECUTING A SERVICE

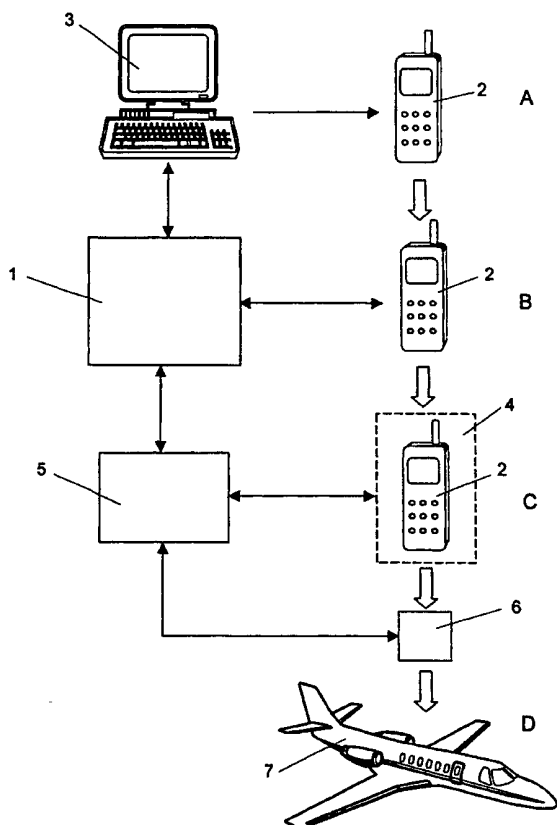

(57) Abstract: The present invention relates to an arrangement for providing a service. The arrangement comprises an ordering unit (1) which is arranged to receive an order of service and issue a proof, related to the authority of the service, to an orderer, a checking unit (6) which is arranged to check said proof in connection with the use of the service and a mobile communication unit (2) which is arranged to be carried by the orderer. Said mobile communication unit (2) comprises an RFID-circuit (Radio Frequency Identification) (8) having a unique RFID-code. A unique ID for the orderer is transmitted and stored in said mobile communication unit (2) in connection with the ordering of said service, whereafter the checking unit (6) is arranged to read said unique ID and RFID-code in the mobile communication unit in order to check the authority of the orderer to the ordered service in connection with the use of the service.



WO 00/74406 A1



— Before the expiration of the time limit for amending the claims and to be republished in the event of receipt of amendments.

For two-letter codes and other abbreviations, refer to the "Guidance Notes on Codes and Abbreviations" appearing at the beginning of each regular issue of the PCT Gazette.

MOBILE COMMUNICATION UNIT COMPRISING A RFID-CIRCUIT FOR EXECUTING A SERVICE

5

TECHNICAL FIELD OF THE INVENTION AND PRIOR ART

10 The present invention relates to an arrangement for providing a service, wherein the arrangement comprises an ordering unit which is arranged to receive an order of a service and issue a proof, related to the authority of the service, to an orderer, a checking unit which is arranged to check said proof in connection with the use of the service and a mobile
15 communication unit which is arranged to be carried by the orderer.

In connection with ordering of services of different kind as, for example, ordering of different kinds of travels or different kinds
20 of events such as concerts, theatres and movies, the handling of tickets requires a lot of time and is relatively costly for the seller and often an inconvenience to an orderer, which has to collect the tickets a time period before the event starts. For persons, which travel a lot, for example, when on duty, the booking of
25 flights and the handling of flight tickets is relatively inflexible. Furthermore, it is required that the person in question must arrive at the airport in good time in order to be able to check in and, if necessary, collect his ticket. A great problem for the airline companies is that persons travelling when on duty often
30 book several departures at different departure times for being certain to obtain a suitable flight, for example, after a meeting which does not have a predetermined end time. This is a great problem for the airline companies, which are forced to decline other passengers because a flight is apparently fully booked.
35 Because of this, the airline companies loose a lot of money. Usually, the airline companies hereby over-book the departures

in order to secure that the plane does not depart with too many vacant seats. This over-booking implies problem both for the passengers and the airline companies.

- 5 Most persons, especially they which are travelling when on duty, usually carry a mobile communication unit, in form of a cellular telephone, in order to be connectable during their travels.

SUMMARY OF THE INVENTION

10

The object of the present invention is to provide an arrangement of the initially mentioned kind, which allows a flexible ordering of services and an uncomplicated checking in connection with the use of the service in order to check the authority of an orderer to
15 the service. Furthermore, the arrangement aims at replacement of tickets in physical form.

20

This object is achieved by the initially mentioned arrangement, which is characterised in that said mobile communication unit
25 comprises an RFID-circuit (Radio Frequency Identification) having a unique RFID-code and that a unique ID for the orderer is transmitted and stored in said mobile communication unit in connection with the ordering of said service, whereafter the checking unit is arranged to read said unique ID and RFID-code
30 in the mobile communication unit in order to check the authority of the orderer to the ordered service in connection with the use of the service. Not only newly manufactured but also existent such mobile communication units, which preferably are a cellular telephone, may be provided with such an RFID-circuit having a
35 unique RFID-code. Such an orderer having such a mobile communication unit receives in connection with the ordering of a service a unique ID, which is transmitted and stored in the mobile communication unit, for example, in the SIM-card of a cellular telephone. By such a unique ID stored in the mobile communication unit, the unit may have substantially the same function as a conventional ticket of paper to the ordered service.

When the orderer will use the service, the checking unit senses said unique ID and RFID-code in the mobile communication unit in order to check if the orderer has authority to said service. This checking may be performed completely mechanically when the orderer with the cellular telephone passes the checking unit. Hereby, the checking unit may control, for example, an automatically openable gate, which only opens if said ID and RFID-code in the cellular telephone of the orderer are correct. The orderer obtains after the passage through the gate access to the ordered service. Alternatively, a signal arrangement may be connected to the checking unit, which signal arrangement indicates by a light or sound signal the authority of the orderer. For in certain cases increase the checking level, the arrangement may be completed with a unique PIN-code for the orderer. This PIN-code may in a suitable way be stored in the mobile communication unit as well as at an entry to the ordered service.

According to a preferred embodiment of present invention, said RFID-circuit is comprised by a battery of the mobile communication unit. Such a battery having an RFID-circuit may be provided in existent mobile communication units instead of the ordinary battery. The existent mobile communication unit, for example, cellular telephones, may thereby in a simple way be equipped with such an RFID-circuit. Preferably, newly manufactured mobile communication units may also be provided with such a battery. Alternatively, said RFID-circuit may be comprised by a master board in the mobile communication unit. In connection with manufacturing of a mobile communication unit, an RFID-circuit may be comprised by the master board of the mobile communication unit. To provide an RFID-circuit in the master board of an already existing mobile communication unit is also possible. Another alternative is that said RFID-circuit comprises by an SIM-card (Subscriber Identification Module) in the mobile communication unit. Preferably, said RFID-circuit is comprised by a microchip. Such a microchip may in a simple

manner be comprised by the above-mentioned parts of the mobile communication unit. Services, which i.a. may be provided to an orderer, having such a carried mobile communication unit, are, for example, accesses to lifts in ski slopes, accesses to roads having duties and accesses to taking part in sporting events having many competitors such as marathon and skiing races, wherein RFID already is used today.

According to another preferred embodiment of the present invention, said unique ID is transmitted to the mobile communication unit by a cable connection. If said service is ordered by a computer, via Internet, an IR-connection or a cable connection may be established between the computer and the cellular telephone in order to transmit said unique ID from the selling unit, via the computer, to the mobile communication unit. Hereby, the RFID-code of the mobile communication unit also may be transmitted to the computer of the ordering unit to be stored there together with said unique ID. If the service instead is ordered at a selling place, one may there transmit said unique ID by one of said connections to the mobile communication unit. Preferably, the RFID-code of the mobile communication unit is, at the same time, stored in the computer of the selling place together with said ID. According to a further alternative, said unique ID is transmitted to the mobile communication unit via its communication system, which, for example, may be a GSM-system of a cellular telephone. Hereby, the service may be ordered by the mobile communication unit, whereafter the ordering unit transmits said unique ID to the mobile communication unit via its communication system and reversibly receives information concerning the RFID-code of the communication unit.

According to another preferred embodiment of the present invention, the checking unit is arranged to check said ID when the orderer passes a checking area intended thereto. Such a checking area may be a passage or the like which the orderer

will pass for being able to use the service. The passage may lead to an electrically controlled gate or the like which automatically is opened if the checking unit senses an ID or an RFID-code in the mobile communication unit, which authorise to
5 said service. Consequently, an authorised orderer for the service carrying a mobile communication unit may walk through said checking area and passes through the gate without the need to take out and show a valid ticket in physical form for the service, which is necessary by, for example, bar codes or IR-
10 technique which may not be hidden in order to function.

According to another preferred embodiment of the present invention, the ordering unit transmits information related to the ordered service to the orderer by the mobile communication unit
15 before said service is used. Since the ordering unit is connectable to the mobile communication unit of the orderer, the ordering unit may inform about possible delays and thereby about new times for the ordered service or inform about other information which may be of interest to the orderer.

20

According to another preferred embodiment of the present invention, the ordering unit locates the positions of each of the orderer by the communication system of the mobile communication units at least a time period before said service is
25 intended to be used, wherein an automatic cancellation is performed of orderers having such a position that a use of the ordered service is made impossible. Hereby, the GSM-system of a cellular telephone may, for example, be used in order to identify and calculate the number of orderers in advanced, which
30 are not going to use the service, wherein ordered services may be transferred to other orderers. Thereby, a flexible arrangement is obtained which results in, for example, that fully booked events also in the practice may be full.

35 According to another preferred embodiment of the present invention, said ordered service is a flight and said ID is a PNR

(Passenger Number Record). Especially, the airline companies will make great economic profits by abolishing the tickets in paper form. Furthermore, the passengers are given the advantage of going on board the plane without the need to pick
5 up and show a ticket. Another advantage for the passenger is that they are allowed to check in by the cellular telephone before they arrive at the airport. Hereby, the passenger receives information about his reserved seat of the aeroplane, which information preferably is stored in the cellular telephone.
10 Thereby, the time, which the passenger must spend at the airport, may be further reduced.

According to another preferred embodiment of the invention, a luggage accompanying the orderer comprises an RFID-circuit
15 having an RFID-code, which corresponds to that of the mobile communication unit of the orderer. This is of particular advantage, if said service concerns a flight. In this manner, the delivering of the luggage is facilitated when it already, at the arrival at the airport, may be provided with a microchip having
20 an RFID-code. Furthermore, the checking of the luggage and the transport to a correct place of destination is simplified by such an RFID-code.

According to another preferred embodiment of the invention, the
25 mobile communication unit comprises an RFID-reader. By such an RFID-reader, the mobile communication unit may be used for several different kinds of services. A carrier of the mobile communication unit may, for example, in connection with parking of a vehicle by the RFID-reader of the mobile communication
30 unit, read an RFID-code in a microchip located at a suitable place of the parking place, in question. At the same time, a measuring of the parking time starts. When the carrier of the mobile communication unit returns to the parking place and the RFID-code is read a second time, the measuring of the parking
35 time is finished. Hereby, an account may automatically debit the carrier of the mobile communication unit for the used parking

time. This will result in great profits for the parking companies in that the staff and the parking equipment essentially may be reduced.

5 BRIEF DESCRIPTION OF THE DRAWINGS

In the following, preferred embodiments of the invention are described as examples with reference to the attached drawings, in which:

10

Fig 1 shows schematically an arrangement according to a first embodiment of the invention,

Fig. 2 shows schematically an arrangement according to a second embodiment of the arrangement,

15 Fig. 3a-c shows different alternative in order to provide an RFID-circuit in a cellular telephone.

DETAILED DESCRIPTION OF PREFERRED EMBODIMENTS OF THE INVENTION

20

Fig. 1 shows schematically an arrangement for ordering of a service in form of a flight. The arrangement comprises an ordering unit 1. The ordering unit 1 is arranged to receive orderings of flights and to issue a unique PNR (Passenger
25 Number Records) for each passenger and travel. Such an ordering unit 1 may comprise an existent ticket booking system on the market. Furthermore, the ordering unit 1 comprises a computer unit which issues unique PNR and stores necessary information concerning the orderer of the flight. Many
30 passengers carrying a cellular telephone 2 on the flight and especially passengers travelling when on duty having almost all a carried cellular telephone 2 in order to be connectable. The arrangement intends to use the carried cellular telephone 2 of the passengers as an "electronic" flight ticket. The handling of
35 the flight tickets in physical form thereby becomes unnecessary and an airline company may thereby make great savings. In

order to make such a use of the cellular telephones 2 possible, they are equipped with a microchip which comprises an RFID-circuit (Radio Frequency Identification) having a unique RFID-code. Such RFID-circuits are used in several different field of applications i.e. in order to mark and identify animals.

In order to book a flight, an orderer may use a computer 3, which, via Internet, is connectable to the ordering unit 1. Such a computer connection is shown in Fig 1 and the cellular telephone 2 is here located in a position A. After the orderer has performed his ordering and delivered necessary information to the ordering unit 1, the ordering unit 1 transmits a unique ID to the computer 1 in form of a PNR. Hereby, the orderer connects his computer 1, for example via a cable connection or an IR-connection, to the cellular telephone 2 such that said unique PNR may be transmitted to the cellular telephone 2 and be stored in for example its SIM-card. At the same time, the ordering unit 1 obtains information about the unique RFID-code of the cellular telephone 2.

Thereafter, the cellular telephone 2 of the orderer is shown in a position B in Fig 1, which symbolises the cellular telephone 2 after the service is ordered but before the service is used by the orderer. During this time period, the ordering unit 1 may transmit information to the cellular telephone 2, which is related to the ordered flight. Such information may concern delays and information about new times of departure. Furthermore, an orderer located in a tax-free shop may obtain information about particular offers in tax-free shops by the cellular telephone 2. Hereby, the tax-free shop may comprise an RFID-reader, at for example the entry of the shop, which identifies the cellular telephone 2 whereafter said information is transmitted. The orderer has also the possibility to check in shortly before the arrival at the airport by his cellular telephone 2. Thereby, the orderer obtains information about his seat reserved in the aeroplane. This information is stored in the cellular telephone 2.

A further advantage of the arrangement is that the ordering unit 1 at least a time period before the time of departure of the aeroplane, in question, may locate the positions of the orderers by the GSM-system of the cellular telephones 2. Thereby, an automatic cancellation may be performed of orderers, which distance to the airport is so great that they cannot arrive at the airport before the time of departure of the aeroplane, in question. Thereby, these ordered seats may be transferred to others.

10

After arrival at the airport, the orderer leaves a possibly accompanied luggage on a place intended thereto. Advantageously, this luggage has in advanced been provided with a microchip with the unique RFID-code of the cellular telephone 2. Thereby, the checking of the luggage is facilitated and the transport to a correct destination. This involves great profits for parties concerned. The passengers save time by a reduced queue time and the staff of the airport may be essentially reduced. Possibly, the passenger must hereafter pass through an examination of passport and a safety control, in a customary way, where also said technique may be used for checking of authority etc.

15
20

Thereafter, the passenger and the carried cellular telephone 2, in position C, are arranged to pass through a checking area 4. The checking area 4 is supervised by a checking unit 5. The checking unit 5 activates, during the passage of the passenger through the checking area 4, the RFID-circuit comprised by the cellular telephone 2 such that its stored RFID-code may be identified and it reads, at the same time, the PNR stored in the cellular telephone 2. Thereafter, the checking unit 5 compares said identified RFID-code and PNR with that stored in the computer of the ordering unit 1. If these codes correspond to each other, the checking unit 5 opens, preferably automatically, a gate 6 such that the orderer carrying the cellular telephone 2 may pass and take his reserved seat in an aeroplane 7, which

25
30
35

occurs in position D. The orderer has obtained information about the reserved seat in the aeroplane at the checking in and this information is preferably stored in the cellular telephone 2. A further advantage of such a cellular telephone 2 is that the orderer may have information in his own language in the cellular telephone 2. Preferably, the language information is stored in a PNR-file.

Fig 2 shows an alternative arrangement in order to provide a flight. The arrangement shown in Fig 2 differs, from that shown in Fig 1, concerning the procedure for ordering of the flight. The flight is here ordered by the cellular telephone 2 of the orderer in position A. After the ordering is received, the ordering unit 1 transmits, via the GSM-system of the cellular telephone, a unique PNR, which is stored in the SIM-card of the cellular telephone 2. At the same time, the ordering unit 1 obtains information about the unique RFID-code of the cellular telephone. In addition to this, the arrangement in Fig 2 is identical to that in Fig 1.

Figs 3a-c show schematically alternative possibilities of providing an RFID-circuit in a cellular telephone 2. Fig. 3a shows a cellular telephone 2 and a battery 7 comprising an RFID-circuit 8. Such a battery 7 allows, in a simple manner, equipment of existent cellular telephones 2 with an RFID-circuit 8, which occurs by replacement of the existent battery in the cellular telephone by one having an RFID-circuit 8.

Fig 3b shows a view through a cellular telephone 2, wherein the master board 9 of the cellular telephone 2 is shown. During manufacturing of cellular telephones, a microchip having an RFID-circuit 8 may hereby be comprised by the master board 9.

Fig 3c shows a SIM-card 10 (Subscriber Identification Module) for a cellular telephone 2. The SIM-card 10 comprises here a

microchip with an RFID-circuit 8 and an antenna 11 intended thereto.

5 The present invention is not in any way restricted to the described embodiments but may be varied freely within the scopes of the claims. The invention is, for example, applicable in connection with ordering of a number of different kinds of services, as travellers with other means of convenience than aviation and different events, for example, in form of concerts, theatres, movies and in connection with the use of ski lifts, local government means of transport, and parking places etc. A problem with conventional cellular telephones is that a stolen one in a simple manner may be decoded such that it again is useable. A cellular telephone comprising a unique RFID-code is not decodeable. Thereby, the present invention also make the use of stolen cellular telephones more difficult.

10

15

Claims

1. An arrangement for providing a service, wherein the arrangement comprises an ordering unit (1), which is arranged
5 to receive an order of a service and issue a proof, related to the authority of the service, to an orderer, a checking unit (6), which is arranged to check said proof in connection with the use of the service, and a mobile communication unit (2) which is arranged to be carried by the orderer, characterised in that said mobile
10 communication unit (2) comprises an RFID-circuit (Radio Frequency Identification) (8) having a unique RFID-code and that a unique ID for the orderer is transmitted and stored in said mobile communication unit (2) in connection with the ordering of said service, whereafter the checking unit (6) is arranged to
15 read said unique ID and RFID-code in the mobile communication unit in order to check the authority of the orderer to the ordered service in connection with the use of the service.
2. An arrangement according to claim 1, characterised in that
20 said RFID-circuit (8) is comprised in a battery (7) of the mobile communication unit.
3. An arrangement according to claim 1, characterised in that
25 said RFID-circuit (8) is comprised by the master board (9) of the mobile communication unit.
4. An arrangement according to claim 1, characterised in that
30 said RFID-circuit (8) is comprised by the SIM-card (10) of the mobile communication unit.
5. An arrangement according to any one of the preceding claims, characterised in that said RFID-circuit (8) is comprised by a microchip.

6. An arrangement according to any one of the preceding claims, characterised in that said unique ID is transmitted to the mobile communication unit (2) by an IR-connection.
- 5 7. An arrangement according to any one of the preceding claims 1 to 5, characterised in that said unique ID is transmitted to the mobile communication unit (2) by a cable connection.
- 10 8. An arrangement according to any one of the preceding claims 1 to 5, characterised in that said unique ID is transmitted to the mobile communication unit (2) by its communication system.
- 15 9. An arrangement according to any one of the preceding claims, characterised in that the checking unit (5) is arranged to check said ID when the orderer passes a checking area intended thereto.
- 20 10. An arrangement according to any one of the preceding claims, characterised in that the ordering unit (1) transmits information related to the ordered service to the orderer by the mobile communication unit (2) before said service is used.
- 25 11. An arrangement according to any one of the preceding claims, characterised in that the ordering unit (1) locates the positions of each of the orderer by the communication system of the mobile communication units (2) at least a time period before said service is intended to be used, wherein an automatic cancellation is performed for orderers having such a position that a use of the ordered service is made impossible.
- 30 12. An arrangement according to any one of the preceding claims, characterised in that said ordered service is a flight and that said ID is a PNR (passenger number record).

13. An arrangement according to claim 12, characterised in that the orderer is allowed to check in by the mobile communication unit (2) before arrival at the airport.

5 14. An arrangement according to any one of the preceding claims, characterised in that a luggage accompanying the orderer comprises an RFID-circuit with an RFID-code, which corresponds to that of the mobile communication unit (2) of the orderer.

10 15. An arrangement according to any one of the preceding claims, characterised in that the mobile communication unit (2) comprises an RFID-reader.

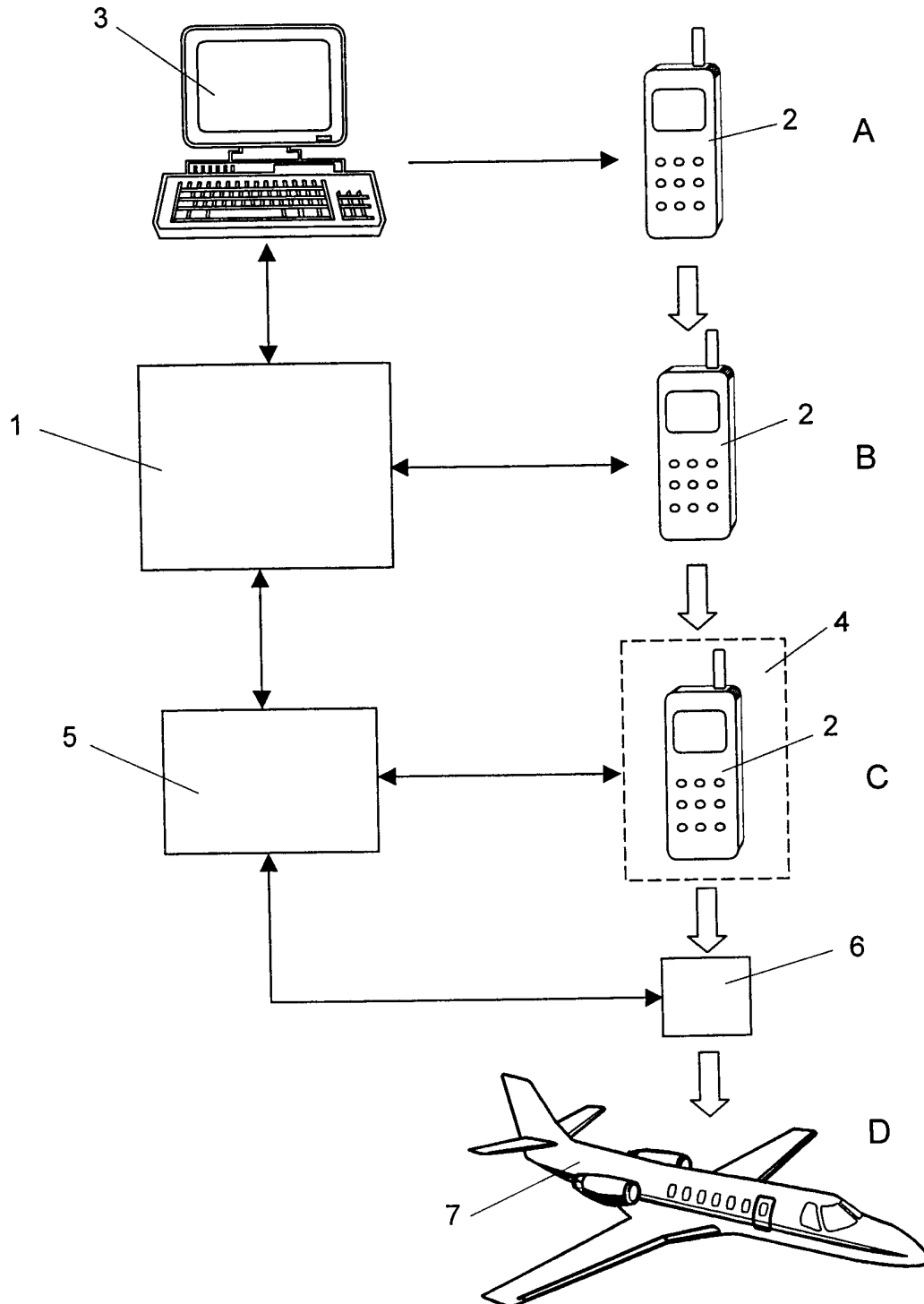

Fig 1

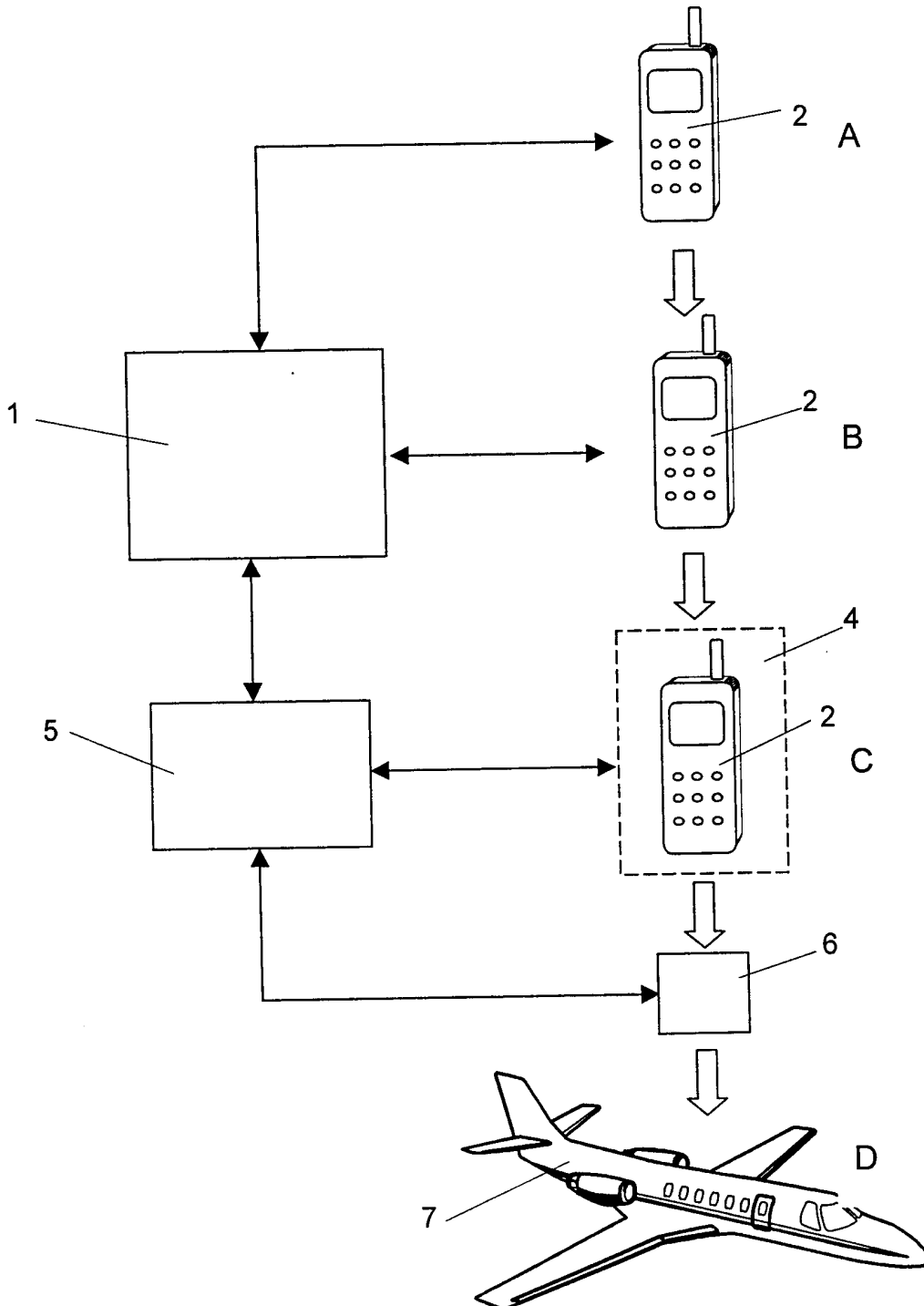

Fig 2

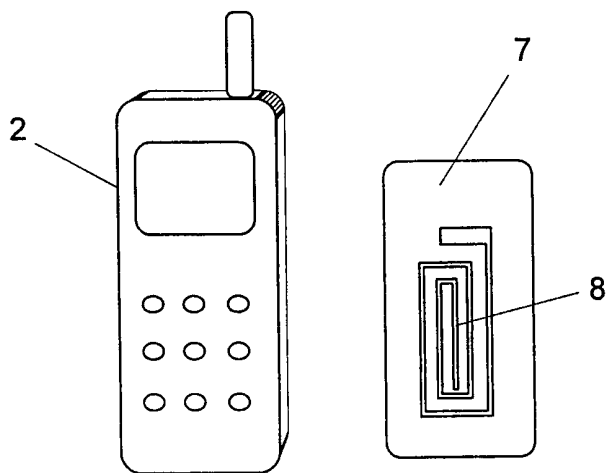

Fig 3a

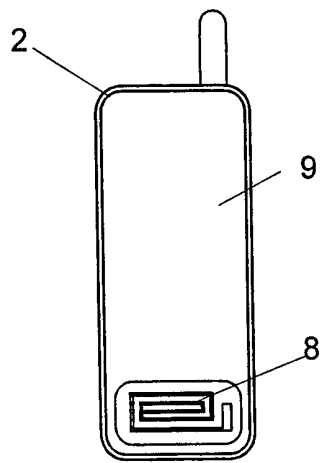

Fig 3b

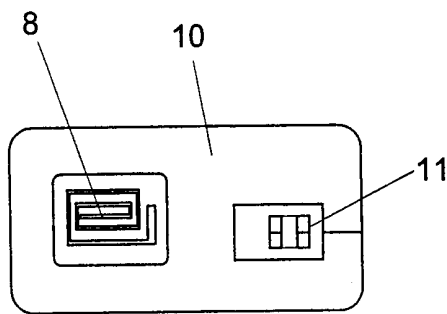

Fig 3c

INTERNATIONAL SEARCH REPORT

International application No.

PCT/SE 00/01084

A. CLASSIFICATION OF SUBJECT MATTER

IPC7: H04Q 7/22, G07C 9/00

According to International Patent Classification (IPC) or to both national classification and IPC

B. FIELDS SEARCHED

Minimum documentation searched (classification system followed by classification symbols)

IPC7: H04Q, G07C

Documentation searched other than minimum documentation to the extent that such documents are included in the fields searched

SE,DK,FI,NO classes as above

Electronic data base consulted during the international search (name of data base and, where practicable, search terms used)

C. DOCUMENTS CONSIDERED TO BE RELEVANT

Category*	Citation of document, with indication, where appropriate, of the relevant passages	Relevant to claim No.
X	WO 9838600 A1 (MICRON COMMUNICATIONS, INC.), 3 Sept 1998 (03.09.98), page 25, line 21 - page 30, line 9; page 5, line 14 - line 17, figure 2, claims 12-16	1-14
Y	--	15
Y	WO 9816070 A1 (AMTECH CORPORATION), 16 April 1998 (16.04.98), page 1, line 22 - page 2, line 3; page 3, line 14 - page 4, line 12, abstract	15
A	US 5740369 A (TOORU YOKOZAWA ET AL), 14 April 1998 (14.04.98)	1-14

 Further documents are listed in the continuation of Box C. See patent family annex.

* Special categories of cited documents:

- "A" document defining the general state of the art which is not considered to be of particular relevance
- "E" earlier application or patent but published on or after the international filing date
- "L" document which may throw doubts on priority claim(s) or which is cited to establish the publication date of another citation or other special reason (as specified)
- "O" document referring to an oral disclosure, use, exhibition or other means
- "P" document published prior to the international filing date but later than the priority date claimed

"T" later document published after the international filing date or priority date and not in conflict with the application but cited to understand the principle or theory underlying the invention

"X" document of particular relevance: the claimed invention cannot be considered novel or cannot be considered to involve an inventive step when the document is taken alone

"Y" document of particular relevance: the claimed invention cannot be considered to involve an inventive step when the document is combined with one or more other such documents, such combination being obvious to a person skilled in the art

"&" document member of the same patent family

Date of the actual completion of the international search

9 November 2000

Name and mailing address of the ISA/
Swedish Patent Office
Box 5055, S-102 42 STOCKHOLM
Facsimile No. +46 8 666 02 86

Date of mailing of the international search report

14 -11- 2000

Authorized officer

Tomas Gustafsson/E1s
Telephone No. +46 8 782 25 00

INTERNATIONAL SEARCH REPORT

International application No.

PCT/SE 00/01084

C (Continuation). DOCUMENTS CONSIDERED TO BE RELEVANT

Category*	Citation of document, with indication, where appropriate, of the relevant passages	Relevant to claim No.
A	WO 9917230 A1 (SCHLASBERG, JOHAN), 8 April 1999 (08.04.99), page 5, line 30 - line 34; page 17, line 13 - line 18, figure 1, abstract --	1-14
A	US 5631947 A (ALAN D. WITTSTEIN ET AL), 20 May 1997 (20.05.97) -- -----	1-14

INTERNATIONAL SEARCH REPORT

International application No.
PCT/SE00/01084

Box I Observations where certain claims were found unsearchable (Continuation of item 1 of first sheet)

This international search report has not been established in respect of certain claims under Article 17(2)(a) for the following reasons:

1. Claims Nos.:
because they relate to subject matter not required to be searched by this Authority, namely:

2. Claims Nos.:
because they relate to parts of the international application that do not comply with the prescribed requirements to such an extent that no meaningful international search can be carried out, specifically:

3. Claims Nos.:
because they are dependent claims and are not drafted in accordance with the second and third sentences of Rule 6.4(a).

Box II Observations where unity of invention is lacking (Continuation of item 2 of first sheet)

This International Searching Authority found multiple inventions in this international application, as follows:

see next page

1. As all required additional search fees were timely paid by the applicant, this international search report covers all searchable claims.
2. As all searchable claims could be searched without effort justifying an additional fee, this Authority did not invite payment of any additional fee.
3. As only some of the required additional search fees were timely paid by the applicant, this international search report covers only those claims for which fees were paid, specifically claims Nos.:

4. No required additional search fees were timely paid by the applicant. Consequently, this international search report is restricted to the invention first mentioned in the claims; it is covered by claims Nos.:

Remark on Protest

- The additional search fees were accompanied by the applicant's protest.
 No protest accompanied the payment of additional search fees.

Unity discussion

Claims 1-14 is dealing with a RFID-circuit comprised in a mobile device for identification purposes. The claimed invention in claim 1 is industrially applicable but is not considered to be new and is not considered to involve an inventive step and claim 15 is dependent of claim 1. The claimed invention in claim 15 is considered to describe an invention not comprised in the thought of the invention in claim 1-14. Claim 15 deals with a RFID reader incorporated into the mobile device. Claim 15 is therefore considered to lack unity a posteriori.

INTERNATIONAL SEARCH REPORT
Information on patent family members

03/10/00

International application No.
PCT/SE 00/01084

WO	9838600	A1	03/09/98	AU	6434798 A	18/09/98
				EP	1012793 A	28/06/00
				US	5914671 A	22/06/99

WO	9816070	A1	16/04/98	EP	0953256 A	03/11/99
				US	6078251 A	20/06/00

US	5740369	A	14/04/98	JP	8008859 A	12/01/96
				JP	8018523 A	19/01/96

WO	9917230	A1	08/04/99	AU	8250098 A	23/04/99
				EP	1016006 A	05/07/00
				SE	0001064 A	26/05/00

US	5631947	A	20/05/97	AU	1550992 A	06/10/92
				CA	2105570 A	05/09/92
				EP	0576552 A	05/01/94
				WO	9216078 A	17/09/92
