

W. FRICK.  
Steering Boats in Train.

No. 238,671.

Patented March 8, 1881.

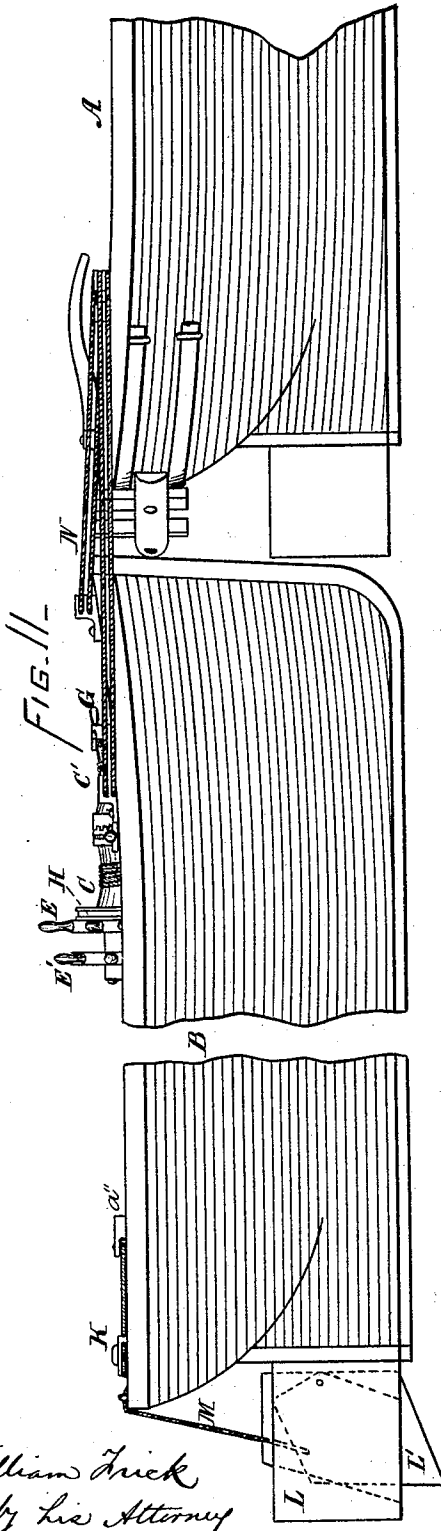
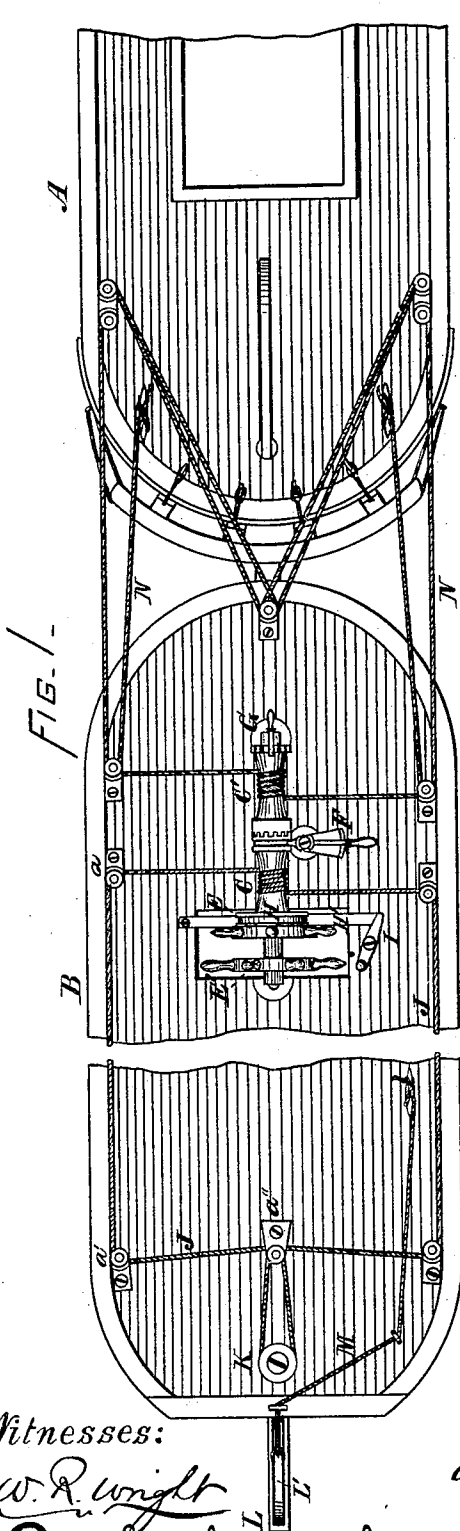

Witnesses:

W. R. Wright  
R. S. Childs

William Frick  
by his Attorney  
George Harding

W. FRICK.  
Steering Boats in Train.

No. 238,671.

Patented March 8, 1881.

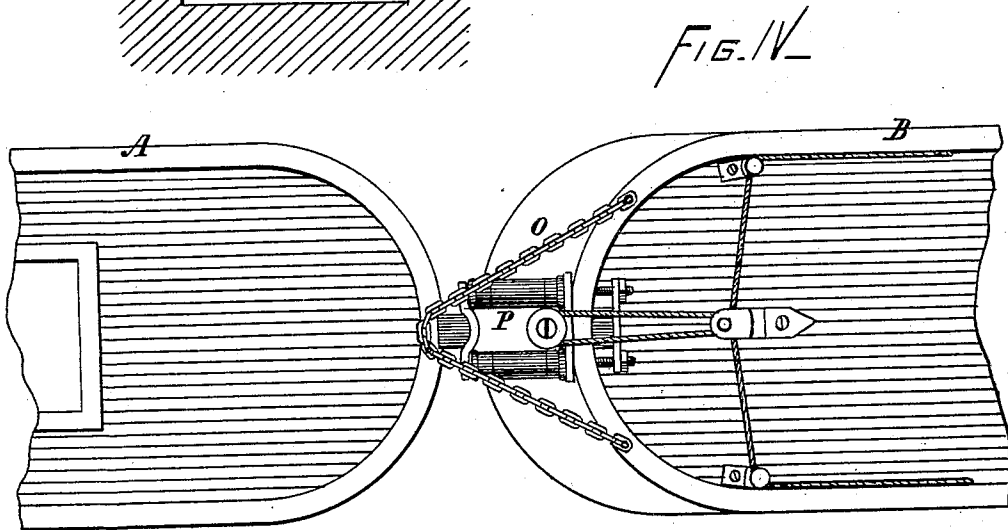
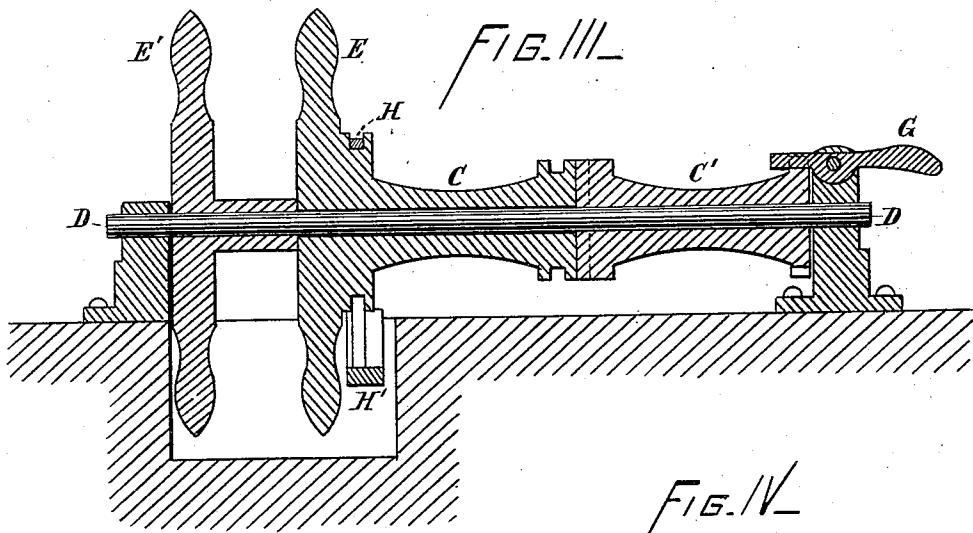

Witnesses:

*W. R. Wright*  
*R. S. Childs Jr*

*William Frick*  
*by his Attorney*  
*George Harding.*

# UNITED STATES PATENT OFFICE.

WILLIAM FRICK, OF CHESTER, PENNSYLVANIA.

## STEERING BOATS IN TRAIN.

SPECIFICATION forming part of Letters Patent No. 238,671, dated March 8, 1881.

Application filed March 11, 1878.

To all whom it may concern:

Be it known that I, WILLIAM FRICK, of the city of Chester, Delaware county, Pennsylvania, have invented new and useful Improvements in Apparatus for Steering Boats in Train, of which the following is a full, clear, and precise description, reference being had to the accompanying drawings, which form part of this specification, and in which—

Figure I is a plan view of part of two canal-boats with my improved apparatus attached; Fig. II, a side view of the same; Fig. III, a longitudinal sectional view of my improved steering-gear; and Fig. IV, a plan view of part of two boats, showing the mode of connection when two or more pairs of boats are drawn in train.

Corresponding parts are indicated by the same letters in all the figures.

My invention relates to the mode of steering boats in train, and is an improvement upon various methods of accomplishing the same heretofore patented by me.

It consists in the combination and arrangement of devices hereinafter described and claimed, but more particularly in the novel construction of the steering apparatus, by which one boat and its rudder may be conjointly employed to steer the train of boats, and devices by which the train of boats may be locked together as one boat, and the whole steered by the rudder of the hindmost boat alone.

It further consists in devices for the more rapid and effective control of the rudder than was possible in the methods heretofore used when the rudder was controlled by the tiller.

In the drawings, A represents the foremost boat, and B the hindmost.

C C' are drums, the foremost of which, C', is journaled on a long shaft, D. The hindmost drum, C, is free to rotate on the shaft, and is controlled by the wheel E, the wheel E' being rigidly connected to the shaft D. The drums C and C' are formed with teeth on the ends, which meet each other on the shaft D, and by means of the lever F, which works in a groove on the drum C, they can be locked together on the shaft.

G is a pawl on the foremost bearing of the shaft D, and so arranged that it can be raised from or lowered into the toothed head secured to the drum C'.

H is a friction-band, which fits over a pulley on the drum C, and is secured at the lower ends to the bar H', which can be pressed down with the foot and held in that position by the catch I, thereby firmly holding the drum and the rudder which it controls in any desired position.

J is the rear tiller rope or chain surrounding the drum C, and controlling the tiller of the hindmost boat by being carried through the chain-blocks a a', and the ends secured to the wheel K on the rudder-post. By this method of controlling the rudder I am enabled by one turn of the pilot-wheel E to cause the rudder to shift from one extreme position on one side of the boat to the other, which rapidity of movement is very important in guiding the boat through the narrow locks and canals. It also permits the rudder to move closely up to the side of the vessel, which was impossible when the ordinary tiller was used, thereby allowing any boat following in the rear to approach closely without danger of breaking the rudder of the foremost boat.

The rudder is formed in two parts, L and L', the part L being so made that the other part, L', can slide up and down inside it, being pivoted to the outer part at b, and secured by the rope or chain M. The object of this arrangement is to provide against the action of wind and strong currents, which, especially when the boat is lightly loaded, cause the wheelsman to lose all control over it. The rope being secured near his position at the wheel, when occasion requires he simply loosens it and allows the part L' to descend.

N is a rope or chain, which conjointly acts as a coupling device and a means of operating the rear boat as a rudder, surrounding and being operated by the drum C'.

Such being the arrangement of my devices, when it is desired to operate the rudder of the hindmost boat as the sole steering device the boats are brought into line and firmly held in such position by locking the drum C' by dropping the pawl G into the toothed head thereof. The drums are then disconnected by the lever F, and the wheel E is used as the means of controlling the rudder.

When it is desired to operate the boat B as a rudder to the foremost boat the drums are locked together and both used for the purpose.

In the narrow canals, when boats are approaching from the rear and desire to pass the train, it is necessary to throw the stern of the rear boat in the train to one side in order to make room for the approaching boat to pass. This is done by disconnecting the two drums C and C' by means of the lever F, and locking the train together by the pawl G, and then using the rudder of the rear boat to swing the stern of the said boat to one side, which at the same time throws the bow of the fore boat to the opposite side, thus preserving the train in line. The friction-band H is then brought into operation for the purpose of holding the rudder in its proper position, while the helmsman uses the other wheel to prevent the bow of the fore boat from running on the bank of the canal. After the bow of the approaching boat has passed the rear end of the train, and secured a position alongside the rear boat of the train, the friction-band can be released, and the forward steering-gear is used to throw the bow of the forward boat of the train away from the bank, thereby giving room for the other boat to pass by. This mode of controlling the train in such cases is necessary, and the only proper way of accomplishing the desired result, as, if the forward steering-gear were used alone, the unavoidable result would be to throw the foremost boat on the bank. The wheel K on the rudder-post is essential in order to swing the rudder rapidly, the desired angle being given by a quarter or less turn of the steering-wheel, which rapidity of movement is very important.

In Fig. IV is shown an improved mode of coupling any one pair of boats, which themselves are coupled, as before described, to a similarly-coupled pair in advance. A is the bow of a boat, (whose stern is shown in Fig. I.)

coupled by means of a chain, O, to the stern of another boat, which is similar to B in Fig. I. P is a spring, of any suitable construction, whose purpose is to relieve the strain on the chain O when the boats rise and fall by the swells caused by the locks. The spring and chain are so constructed that the boats are firmly held in line, the bow of the rear boat being closely held by means of the chain in the recess of the spring upon the foremost boat, as shown in the drawings. When this coupling is disconnected, as in passing through locks, the spring P must be drawn in, by means of a lever or other suitable means, beyond the line of the overhanging guard, to prevent its being caught and broken on the gates or sides of the lock.

Having thus described my invention, what I claim, and desire to secure by Letters Patent of the United States, is—

1. In combination with two boats arranged for the purpose of steering one by the other, a double-wheel steering apparatus, substantially as shown and described.

2. In combination with the double wheels E and E' of two canal-boats, combined and arranged as described for the purpose of steering one by the other, the drums C and C', lever F, and pawl G, substantially as shown and described.

3. A chain for coupling two or more boats in train, in combination with a spring so constructed that the bow of the rear boat shall fit into a recess formed in the spring, for the purpose of firmly securing the train of boats in line, substantially as shown and described.

WILLIAM FRICK.

Witnesses:

JOHN R. BENNETT,  
W. R. WRIGHT.