

M. A. Crooker.
Paddle Wheel.
N^o 107,340. Patented Sept. 13, 1870.

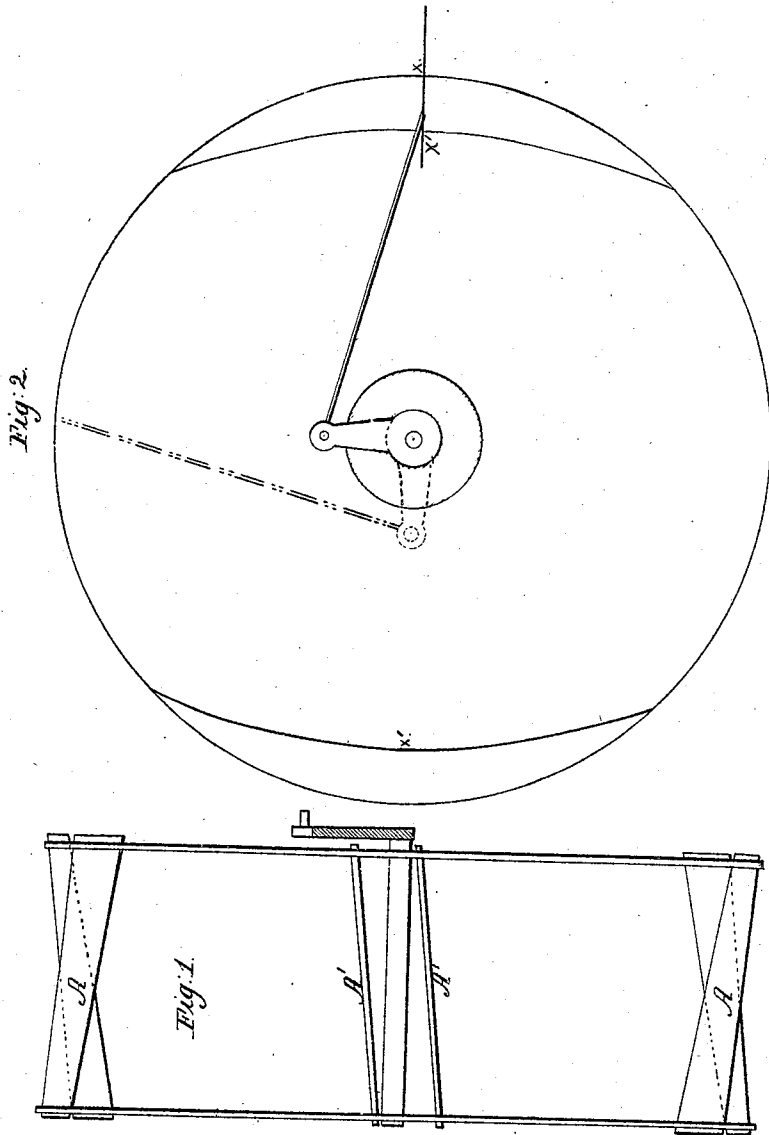

Witnesses
Marshall H. Brooks
Mathias Barringer

Inventor,
Mattias A. Crooker

UNITED STATES PATENT OFFICE.

MATTHEW A. CROOKER, OF NEW YORK, N. Y.

IMPROVEMENT IN PADDLE-WHEELS.

Specification forming part of Letters Patent No. **107,340**, dated September 13, 1870.

I, MATTHEW A. CROOKER, of the city and county of New York, have invented certain Improvements in Paddle-wheels for Steam-Vessels, of which the following is the specification:

Letters Patent were issued to me under date of October 28, 1856, for certain improvements in paddle-wheels, said Letters Patent having been reissued April 26, 1859, and in the specification pertaining to said Letters Patent I stated as follows: "The principle of my invention lies in securing the buckets to the arms upon curved lines, which are segments of a circle greater than a circle struck from the center or axis of the wheel."

In my present improvement I employ the same principle in an improved manner; but the novelty and utility of my present invention lies chiefly in the peculiar angulation of the buckets, both in form and position.

Figure 1 of the accompanying drawing represents a vertical section of my improved wheel, with a sufficient number only of the buckets represented to show the nature of my improved angulation. Fig. 2 is a diagram, showing the mean curve on which I set my buckets (intracted from the complete circle) as a fixed system, the crank (shown in full lines) being in proper position as regards the wheel as a whole, when driven by a horizontal engine, and the crank shown in dotted lines represents its proper position in regard to the wheel when driven by a vertical or beam engine.

The line of the outer edge of the intracted buckets I make to correspond (as a fixed system) with an arc of a circle, whose center, X, would be on the peripheral line of the wheel, if the outer dip of the buckets was on a complete circle, as will be understood, such line being shown by X', Fig. 2, thus making the outline of the wheel as if it were a double cam, and as the buckets adjoining the junction of the line X' with the full circle enter the water, they get a special "gripe," so to speak, when the engine is in its most advantageous condition of power, especially when a "cut-off" is used, and the steam is cut off short.

In regard to the angulations of the buckets of my improved paddle-wheel, the angulations

are threefold, as follows: First, the buckets are tapered, being of less width at one end than at the other. (See A, Fig. 1.) Next, as shown, A, the broadest end is set nearest the shaft. I should here remark that I am aware that buckets so angulated as regards position in this respect have been heretofore used, but, so far as I am aware, they were of uniform width, the object of such angulation of the buckets being to obviate the jar and tremor produced by buckets fixed parallel to the shaft, as they strike and enter the water, as will be understood, and the object is partially effected by that plan, but not entirely; but I have found, by experiment, that by tapering the buckets so that their outer extremities, which describe a greater circle, have a swifter motion, this object is completely attained—that is to say, the complete avoidance of the injurious vibration referred to—and this feature of my improvement will be specially marked when a steamer is propelling against a short head sea. Finally, I angulate my paddles, as shown by A', Fig. 1, by fixing the broad end of the bucket to a given arm, and the narrow end of the bucket to the next arm in succession on the opposite side, substantially as shown. This arrangement of the buckets is important as applied to the paddle-wheels of steamboats running in shallow waters, and specially to boats that have to cross "bars" with a very small margin of draft over the given bar or bars.

As is well known to managers of steamboats running in such waters, paddle-wheels with buckets set parallel to the shaft will draw the water from under the boat, and thus add to her difficulties of progress, particularly over a bar or other very shallow portion of her course. This is owing to the law of confluent currents, as will be well understood.

By this last-explained angulation of the buckets of my paddle-wheel, turning so that the crank approaches the observer, looking at Fig. 1, and the crank, of course, being in-board, it will be seen that the water will be thrown in toward the boat, reversing the fault above referred to, and, at the same time, per necessity, reducing the slip to a minimum.

I am aware that the buckets of certain pad-

dle-wheels have been adjusted on different radii, and, at the beginning of this specification, have referred to a patent previously granted to me, in which I claimed arranging the buckets so that they should be continuously increasing and diminishing their depths in the water as the wheel revolved. I do not, therefore, claim fixing the "intracted" buckets of my improved paddle-wheel "upon curved lines which are segments of a circle greater than a circle struck from the center or axis of the wheel;" but

I claim—

The tapering buckets set and arranged with a twofold angulation, (shown by A and A', Fig. 1,) and substantially as described, for the purposes explained.

MATTHEW A. CROOKER.

Witnesses:

MATTHEW H. CROOKER,
MATHIAS BARINGER.