



- (51) International Patent Classification:
A61B 5/1477 (2006.01)
- (21) International Application Number:
PCT/US2013/075700
- (22) International Filing Date:
17 December 2013 (17.12.2013)
- (25) Filing Language: English
- (26) Publication Language: English
- (30) Priority Data:
61/747,472 31 December 2012 (31.12.2012) US
- (71) Applicant: OMNI MEDSCI, INC. [US/US]; 1718 Newport Creek Drive, Ann Arbor, Michigan 48103 (US).
- (72) Inventor: ISLAM, Mohammed N.; 1718 Newport Creek Drive, Ann Arbor, Michigan 48103 (US).
- (74) Agents: BIR, David S. et al.; Brooks Kushman P.C., 1000 Town Center, Twenty-Second Floor, Southfield, Michigan 48075 (US).
- (81) Designated States (unless otherwise indicated, for every kind of national protection available): AE, AG, AL, AM, AO, AT, AU, AZ, BA, BB, BG, BH, BN, BR, BW, BY, BZ, CA, CH, CL, CN, CO, CR, CU, CZ, DE, DK, DM, DO, DZ, EC, EE, EG, ES, FI, GB, GD, GE, GH, GM, GT,

HN, HR, HU, ID, IL, IN, IR, IS, JP, KE, KG, KN, KP, KR, KZ, LA, LC, LK, LR, LS, LT, LU, LY, MA, MD, ME, MG, MK, MN, MW, MX, MY, MZ, NA, NG, NI, NO, NZ, OM, PA, PE, PG, PH, PL, PT, QA, RO, RS, RU, RW, SA, SC, SD, SE, SG, SK, SL, SM, ST, SV, SY, TH, TJ, TM, TN, TR, TT, TZ, UA, UG, US, UZ, VC, VN, ZA, ZM, ZW.

(84) Designated States (unless otherwise indicated, for every kind of regional protection available): ARIPO (BW, GH, GM, KE, LR, LS, MW, MZ, NA, RW, SD, SL, SZ, TZ, UG, ZM, ZW), Eurasian (AM, AZ, BY, KG, KZ, RU, TJ, TM), European (AL, AT, BE, BG, CH, CY, CZ, DE, DK, EE, ES, FI, FR, GB, GR, HR, HU, IE, IS, IT, LT, LU, LV, MC, MK, MT, NL, NO, PL, PT, RO, RS, SE, SI, SK, SM, TR), OAPI (BF, BJ, CF, CG, CI, CM, GA, GN, GQ, GW, KM, ML, MR, NE, SN, TD, TG).

Declarations under Rule 4.17:

- as to applicant's entitlement to apply for and be granted a patent (Rule 4.17(ii))
- as to the applicant's entitlement to claim the priority of the earlier application (Rule 4.17(iii))

Published:

- with international search report (Art. 21(3))

[Continued on next page]

(54) Title: NEAR-INFRARED LASERS FOR NON-INVASIVE MONITORING OF GLUCOSE, KETONES, HBA1C, AND OTHER BLOOD CONSTITUENTS

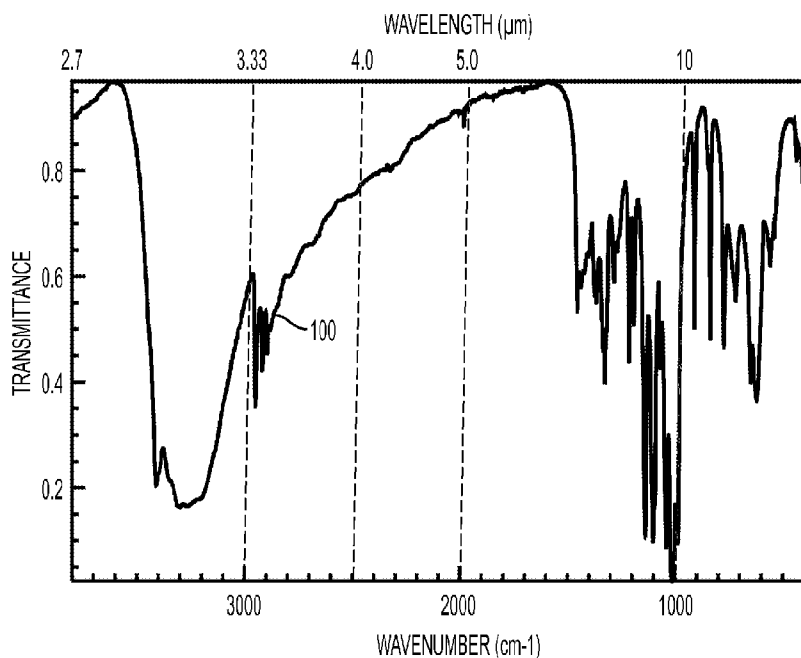

(57) Abstract: Non-invasive monitoring of blood constituents such as glucose, ketones, or hemoglobin A1c may be accomplished using near-infrared or short-wave infrared (SWIR) light sources through absorbance, diffuse reflection, or transmission spectroscopy. As an example, hydro-carbon related substances such as glucose or ketones have distinct spectral features in the SWIR between approximately 1500 and 2500nm. An SWIR super-continuum laser based on laser diodes and fiber optics may be used as the light source for the non-invasive monitoring. Light may be transmitted or reflected through a tooth, since an intact tooth and its enamel and dentine may be nearly transparent in the SWIR. Blood constituents or analytes within the capillaries in the dental pulp may be detected. The non-invasive monitoring device may communicate with a device such as a smart phone or tablet, which may transmit a signal related to the measurement to the cloud with cloud-based value-added services.

WO 2014/105520 A1

- *before the expiration of the time limit for amending the claims and to be republished in the event of receipt of amendments (Rule 48.2(h))*

NEAR-INFRARED LASERS FOR NON-INVASIVE MONITORING OF GLUCOSE, KETONES,
HBA1C, AND OTHER BLOOD CONSTITUENTS

CROSS-REFERENCE TO RELATED APPLICATIONS

[0001] This application claims the benefit of U.S. provisional application Serial No. 61/747,472 filed December 31, 2012, the disclosure of which is hereby incorporated by reference in its entirety.

[0002] This application is related to U.S. provisional application Serial Nos. 61/747,477 filed December 31, 2012; Serial No. 61/747,481 filed December 31, 2012; Serial No. 61/747,485 filed December 31, 2012; Serial No. 61/747,487 filed December 31, 2012; Serial No. 61/747,492 filed December 31, 2012; Serial No. 61/747,553 filed December 31, 2012; and Serial No. 61/754,698 filed January 21, 2013, the disclosures of which are hereby incorporated in their entirety by reference herein.

[0003] This application is being filed concurrently with International Application _____ entitled Short-Wave Infrared Super-Continuum Lasers For Early Detection Of Dental Caries (Attorney Docket No. OMNI0102PCT); U.S. Application _____ entitled Focused Near-Infrared Lasers For Non-Invasive Vasectomy And Other Thermal Coagulation Or Occlusion Procedures (Attorney Docket No. OMNI0103PUSP); International Application _____ entitled Short-Wave Infrared Super-Continuum Lasers For Natural Gas Leak Detection, Exploration, And Other Active Remote Sensing Applications (Attorney Docket No. OMNI0104PCT); U.S. Application _____ entitled Short-Wave Infrared Super-Continuum Lasers For Detecting Counterfeit Or Illicit Drugs And Pharmaceutical Process Control (Attorney Docket No. OMNI0105PUSP); U.S. Application _____ entitled Non-Invasive Treatment Of Varicose Veins (Attorney Docket No. OMNI0106PUSP); and U.S. Application _____ entitled Near-Infrared Super-Continuum Lasers For Early Detection Of Breast And Other Cancers (Attorney Docket No. OMNI0107PUSP), the disclosures of which are hereby incorporated in their entirety by reference herein.

TECHNICAL FIELD

[0004] This disclosure relates in general to lasers and light sources for healthcare, medical, or bio-technology applications including systems and methods for using near-infrared light sources for non-invasive monitoring of different blood constituents or blood analytes, such as glucose, ketones, and hemoglobin A1C (HbA1C).

BACKGROUND AND SUMMARY

[0005] With the growing obesity epidemic, the number of individuals with diabetes is also increasing dramatically. For example, there are over 200 million people who have diabetes. Diabetes control requires monitoring of the glucose level, and most glucose measuring systems available commercially require drawing of blood. Depending on the severity of the diabetes, a patient may have to draw blood and measure glucose four to six times a day. This may be extremely painful and inconvenient for many people. In addition, for some groups, such as soldiers in the battlefield, it may be dangerous to have to measure periodically their glucose level with finger pricks.

[0006] Thus, there is an unmet need for non-invasive glucose monitoring (e.g., monitoring glucose without drawing blood). The challenge has been that a non-invasive system requires adequate sensitivity and selectivity, along with repeatability of the results. Yet, this is a very large market, with an estimated annual market of over \$10B in 2011 for self-monitoring of glucose levels.

[0007] One approach to non-invasive monitoring of blood constituents or blood analytes is to use near-infrared spectroscopy, such as absorption spectroscopy or near-infrared diffuse reflection or transmission spectroscopy. Some attempts have been made to use broadband light sources, such as tungsten lamps, to perform the spectroscopy. However, several challenges have arisen in these efforts. First, many other constituents in the blood also have signatures in the near-infrared, so spectroscopy and pattern matching, often called spectral fingerprinting, is required to distinguish the glucose with sufficient confidence. Second, the non-invasive procedures have often transmitted or reflected light through the skin, but skin has many spectral artifacts in the near-infrared that may

mask the glucose signatures. Moreover, the skin may have significant water and blood content. These difficulties become particularly complicated when a weak light source is used, such as a lamp. More light intensity can help to increase the signal levels, and, hence, the signal-to-noise ratio.

[0008] As described in this disclosure, by using brighter light sources, such as fiber-based supercontinuum lasers, super-luminescent laser diodes, light-emitting diodes or a number of laser diodes, the near-infrared signal level from blood constituents may be increased. By shining light through the teeth, which have fewer spectral artifacts than skin in the near-infrared, the blood constituents may be measured with less interfering artifacts. Also, by using pattern matching in spectral fingerprinting and various software techniques, the signatures from different constituents in the blood may be identified. Moreover, value-add services may be provided by wirelessly communicating the monitored data to a handheld device such as a smart phone, and then wirelessly communicating the processed data to the cloud for storing, processing, and transmitting to several locations.

SUMMARY OF EXAMPLE EMBODIMENTS

[0009] In one embodiment, a measurement system includes a light source generating an output optical beam comprising a plurality of semiconductor sources generating an input optical beam, a multiplexer configured to receive at least a portion of the input optical beam and to form an intermediate optical beam, one or more fibers configured to receive at least a portion of the intermediate optical beam and to form the output optical beam, wherein the output optical beam comprises one or more optical wavelengths. An interface device is configured to receive at least a portion of the output optical beam and to deliver the portion of the output optical beam to a sample comprising at least in part enamel, dentine and pulp, wherein the portion of the output optical beam is configured to generate a spectroscopy output beam from the sample. A receiver is configured to receive at least a portion of the spectroscopy output beam and to process the portion of the spectroscopy output beam to generate an output signal representing at least in part a property of blood contained within the pulp.

[0010] In another embodiment a diagnostic system includes a light source generating an output optical beam comprising a plurality of semiconductor sources generating an input optical beam, a multiplexer configured to receive at least a portion of the input optical beam and to form an intermediate optical beam, and one or more fibers configured to receive at least a portion of the intermediate optical beam and to form the output optical beam, wherein the output optical beam comprises one or more optical wavelengths, wherein at least a portion of the one or more optical wavelengths comprises a short-wave infrared wavelength between approximately 1400 nanometers and approximately 2500 nanometers, and wherein at least a portion of the one of more fibers is a fused silica fiber with a core diameter less than approximately 400 microns. An interface device is configured to receive at least a portion of the output optical beam and to deliver the portion of the output optical beam to a sample, wherein the portion of the output optical beam is configured to generate a spectroscopy output beam from the sample. A receiver is configured to receive at least a portion of the spectroscopy output beam having a bandwidth of at least 20 nanometers and to process the portion of the spectroscopy output beam to generate an output signal representing at least in part a property of hydro-carbon bonds.

[0011] In yet another embodiment, a method of measuring includes generating an output optical beam comprising generating an input optical beam from a plurality of semiconductor sources, multiplexing at least a portion of the input optical beam and forming an intermediate optical beam, guiding at least a portion of the intermediate optical beam and forming the output optical beam, wherein the output optical beam comprises one or more optical wavelengths. The method also may include receiving at least a portion of the output optical beam and delivering the portion of the output optical beam to a sample, wherein the sample comprises at least in part enamel, dentine and pulp. The method also includes generating a spectroscopy output beam from the sample, receiving at least a portion of the spectroscopy output beam, and processing the portion of the spectroscopy output beam and generating an output signal representing at least in part a property of blood contained within the pulp.

[0012] In one embodiment, a diagnostic system includes a light source configured to generate an output optical beam comprising one or more semiconductor sources configured to

generate an input beam, one or more optical amplifiers configured to receive at least a portion of the input beam and to deliver an intermediate beam to an output end of the one or more optical amplifiers, and one or more optical fibers configured to receive at least a portion of the intermediate beam and to deliver at least the portion of the intermediate beam to a distal end of the one or more optical fibers to form a first optical beam. A nonlinear element is configured to receive at least a portion of the first optical beam and to broaden a spectrum associated with the at least a portion of the first optical beam to at least 10 nanometers through a nonlinear effect in the nonlinear element to form the output optical beam with an output beam broadened spectrum, wherein at least a portion of the output beam broadened spectrum comprises a short-wave infrared wavelength between approximately 1400 nanometers and approximately 2500 nanometers, and wherein at least a portion of the one of more fibers is a fused silica fiber with a core diameter less than approximately 400 microns. An interface device is configured to receive a received portion of the output optical beam and to deliver a delivered portion of the output optical beam to a sample, wherein the delivered portion of the output optical beam is configured to generate a spectroscopy output beam from the sample. A receiver is configured to receive at least a portion of the spectroscopy output beam having a bandwidth of at least 10 nanometers and to process the portion of the spectroscopy output beam to generate an output signal representing at least in part a property of hydro-carbon bonds.

[0013] In another embodiment, a measurement system includes a light source generating an output optical beam comprising a plurality of semiconductor sources generating an input optical beam, a multiplexer configured to receive at least a portion of the input optical beam and to form an intermediate optical beam, and one or more fibers configured to receive at least a portion of the intermediate optical beam and to form the output optical beam, wherein the output optical beam comprises one or more optical wavelengths. An interface device is configured to receive a received portion of the output optical beam and to deliver a delivered portion of the output optical beam to a sample comprising at least in part enamel, dentine and pulp, wherein the delivered portion of the output optical beam is configured to generate a spectroscopy output beam from the sample. A receiver is configured to receive at least a portion of the spectroscopy output beam and to process the portion of the spectroscopy output beam to generate an output signal representing at least in part a property of blood contained within the pulp.

[0014] In yet another embodiment, a method of measuring includes generating an output optical beam comprising generating an input optical beam from a plurality of semiconductor sources, multiplexing at least a portion of the input optical beam and forming an intermediate optical beam, and guiding at least a portion of the intermediate optical beam and forming the output optical beam, wherein the output optical beam comprises one or more optical wavelengths. The method may also include receiving a received portion of the output optical beam and delivering a delivered portion of the output optical beam to a sample, wherein the sample comprises at least in part enamel, dentine and pulp. The method further may include generating a spectroscopy output beam from the sample, receiving at least a portion of the spectroscopy output beam, and processing the portion of the spectroscopy output beam and generating an output signal representing at least in part a property of blood contained within the pulp.

BRIEF DESCRIPTION OF THE DRAWINGS

[0015] For a more complete understanding of the present disclosure, and for further features and advantages thereof, reference is now made to the following description taken in conjunction with the accompanying drawings, in which:

[0016] FIGURE 1 plots the transmittance versus wavenumber for glucose in the mid-wave and long-wave infrared wavelengths between approximately 2.7 to 12 microns.

[0017] FIGURE 2 illustrates measurements of the absorbance of different blood constituents, such as glucose, hemoglobin, and hemoglobin A1c. The measurements are done using an FTIR spectrometer in samples with a 1mm path length.

[0018] FIGURE 3A shows the normalized absorbance of water and glucose (not drawn to scale). Water shows transmission windows between about 1500-1850nm and 2050-2500nm.

[0019] FIGURE 3B illustrates the absorbance of hemoglobin and oxygenated hemoglobin overlapped with water.

[0020] FIGURE 4A shows measured absorbance in different concentrations of glucose solution over the wavelength range of about 2000 to 2400nm. This data is collected using a SWIR super-continuum laser with the sample path length of about 1.1mm.

[0021] FIGURE 4B illustrates measured absorbance in different concentrations of glucose solution over the wavelength range of about 1550 to 1800nm. The data is collected using a SWIR super-continuum laser with a sample path length of about 10mm.

[0022] FIGURE 5 illustrates the spectrum for different blood constituents in the wavelength range of about 2 to 2.45 microns (2000 to 2450nm).

[0023] FIGURE 6 shows the transmittance versus wavelength in microns for the ketone 3-hydroxybutyrate. The wavelength range is approximately 2 to 16 microns.

[0024] FIGURE 7 illustrates the optical absorbance for ketones as well as some other blood constituents in the wavelength range of about 2100 to 2400nm.

[0025] FIGURE 8A shows the first derivative spectra of ketone and protein at concentrations of 10g/L (left). In addition, the first derivative spectra of urea, creatinine, and glucose are shown on the right at concentrations of 10g/L.

[0026] FIGURE 8B illustrates the near infrared absorbance for triglyceride.

[0027] FIGURE 8C shows the near-infrared reflectance spectrum for cholesterol.

[0028] FIGURE 8D illustrates the near-infrared reflectance versus wavelength for various blood constituents, including cholesterol, glucose, albumin, uric acid, and urea.

[0029] FIGURE 9 shows a schematic of the human skin. In particular, the dermis may comprise significant amounts of collagen, elastin, lipids, and water.

[0030] FIGURE 10 illustrates the absorption coefficients for water (including scattering), adipose, collagen, and elastin.

[0031] FIGURE 11 shows the dorsal of the hand, where a differential measurement may be made to at least partially compensate for or subtract out the skin interference.

[0032] FIGURE 12 shows the dorsal of the foot, where a differential measurement may be made to at least partially compensate for or subtract out the skin interference.

[0033] FIGURE 13 illustrates a typical human nail tissue structure and the capillary vessels below it.

[0034] FIGURE 14 shows the attenuation coefficient for seven nail samples that are allowed to stand in an environment with a humidity level of 14%. These coefficients are measured using an FTIR spectrometer over the near-infrared wavelength range of approximately 1 to 2.5 microns. Below is also included the spectrum of glucose.

[0035] FIGURE 15 illustrates the structure of a tooth.

[0036] FIGURE 16A shows the attenuation coefficient for dental enamel and water versus wavelength from approximately 600nm to 2600nm.

[0037] FIGURE 16B illustrates the absorption spectrum of intact enamel and dentine in the wavelength range of approximately 1.2 to 2.4 microns.

[0038] FIGURE 17 shows the near infrared spectral reflectance over the wavelength range of approximately 800nm to 2500nm from an occlusal tooth surface. The black diamonds correspond to the reflectance from a sound, intact tooth section. The asterisks correspond to a tooth section with an enamel lesion. The circles correspond to a tooth section with a dentine lesion.

[0039] FIGURE 18A illustrates a clamp design of a human interface to cap over one or more teeth and perform a non-invasive measurement of blood constituents.

[0040] FIGURE 18B shows a mouth guard design of a human interface to perform a non-invasive measurement of blood constituents.

[0041] FIGURE 19 illustrates a block diagram or building blocks for constructing high power laser diode assemblies.

[0042] FIGURE 20 shows a platform architecture for different wavelength ranges for an all-fiber-integrated, high powered, super-continuum light source.

[0043] FIGURE 21 illustrates one embodiment of a short-wave infrared (SWIR) super-continuum (SC) light source.

[0044] FIGURE 22 shows the output spectrum from the SWIR SC laser of FIGURE 21 when ~10m length of fiber for SC generation is used. This fiber is a single-mode, non-dispersion shifted fiber that is optimized for operation near 1550nm.

[0045] FIGURE 23 illustrates high power SWIR-SC lasers that may generate light between approximately 1.4-1.8 microns (top) or approximately 2-2.5 microns (bottom).

[0046] FIGURE 24 schematically shows that the medical measurement device can be part of a personal or body area network that communicates with another device (e.g., smart phone or tablet) that communicates with the cloud. The cloud may in turn communicate information with the user, healthcare providers, or other designated recipients.

DETAILED DESCRIPTION

[0047] As required, detailed embodiments of the present disclosure are disclosed herein; however, it is to be understood that the disclosed embodiments are merely exemplary of the disclosure that may be embodied in various and alternative forms. The figures are not necessarily to scale; some features may be exaggerated or minimized to show details of particular components. Therefore, specific structural and functional details disclosed herein are not to be interpreted as limiting, but merely as a representative basis for teaching one skilled in the art to variously employ the present disclosure.

[0048] Various ailments or diseases may require measurement of the concentration of one or more blood constituents. For example, diabetes may require measurement of the blood glucose and HbA1c levels. On the other hand, diseases or disorders characterized by impaired glucose metabolism may require the measurement of ketone bodies in the blood. Examples of impaired glucose metabolism diseases include Alzheimer's, Parkinson's, Huntington's, and Lou Gehrig's or amyotrophic lateral sclerosis (ALS). Techniques related to near-infrared spectroscopy or hyper-spectral imaging may be particularly advantageous for non-invasive monitoring of some of these blood constituents.

[0049] As used throughout this document, the term "couple" and or "coupled" refers to any direct or indirect communication between two or more elements, whether or not those elements are physically connected to one another. As used throughout this disclosure, the term "spectroscopy" means that a tissue or sample is inspected by comparing different features, such as wavelength (or frequency), spatial location, transmission, absorption, reflectivity, scattering, refractive index, or opacity. In one embodiment, "spectroscopy" may mean that the wavelength of the light source is varied, and the transmission, absorption or reflectivity of the tissue or sample is measured as a function of wavelength. In another embodiment, "spectroscopy" may mean that the wavelength dependence of the transmission, absorption or reflectivity is compared between different spatial locations on a tissue or sample. As an illustration, the "spectroscopy" may be performed by varying the wavelength of the light source, or by using a broadband light source and analyzing the signal using a spectrometer, wavemeter, or optical spectrum analyzer.

[0050] As used throughout this document, the term "fiber laser" refers to a laser or oscillator that has as an output light or an optical beam, wherein at least a part of the laser comprises an optical fiber. For instance, the fiber in the "fiber laser" may comprise one of or a combination of a single mode fiber, a multi-mode fiber, a mid-infrared fiber, a photonic crystal fiber, a doped fiber, a gain fiber, or, more generally, an approximately cylindrically shaped waveguide or light-pipe. In one embodiment, the gain fiber may be doped with rare earth material, such as ytterbium, erbium, and/or thulium. In another embodiment, the mid-infrared fiber may comprise one or a combination of fluoride fiber, ZBLAN fiber, chalcogenide fiber, tellurite fiber, or germanium doped fiber. In yet

another embodiment, the single mode fiber may include standard single-mode fiber, dispersion shifted fiber, non-zero dispersion shifted fiber, high-nonlinearity fiber, and small core size fibers.

[0051] As used throughout this disclosure, the term “pump laser” refers to a laser or oscillator that has as an output light or an optical beam, wherein the output light or optical beam is coupled to a gain medium to excite the gain medium, which in turn may amplify another input optical signal or beam. In one particular example, the gain medium may be a doped fiber, such as a fiber doped with ytterbium, erbium or thulium. In one embodiment, the “pump laser” may be a fiber laser, a solid state laser, a laser involving a nonlinear crystal, an optical parametric oscillator, a semiconductor laser, or a plurality of semiconductor lasers that may be multiplexed together. In another embodiment, the “pump laser” may be coupled to the gain medium by using a fiber coupler, a dichroic mirror, a multiplexer, a wavelength division multiplexer, a grating, or a fused fiber coupler.

[0052] As used throughout this document, the term “super-continuum” and or “supercontinuum” and or “SC” refers to a broadband light beam or output that comprises a plurality of wavelengths. In a particular example, the plurality of wavelengths may be adjacent to one-another, so that the spectrum of the light beam or output appears as a continuous band when measured with a spectrometer. In one embodiment, the broadband light beam may have a bandwidth of at least 10nm. In another embodiment, the “super-continuum” may be generated through nonlinear optical interactions in a medium, such as an optical fiber or nonlinear crystal. For example, the “super-continuum” may be generated through one or a combination of nonlinear activities such as four-wave mixing, the Raman effect, modulational instability, and self-phase modulation.

[0053] As used throughout this disclosure, the terms “optical light” and or “optical beam” and or “light beam” refer to photons or light transmitted to a particular location in space. The “optical light” and or “optical beam” and or “light beam” may be modulated or unmodulated, which also means that they may or may not contain information. In one embodiment, the “optical light” and or “optical beam” and or “light beam” may originate from a fiber, a fiber laser, a laser, a light emitting diode, a lamp, a pump laser, or a light source.

SPECTRUM FOR GLUCOSE

[0054] One molecule of interest is glucose. The glucose molecule has the chemical formula $C_6H_{12}O_6$, so it has a number of hydro-carbon bonds. An example of the infrared transmittance of glucose 100 is illustrated in FIGURE 1. The vibrational spectroscopy shows that the strongest lines for bending and stretching modes of C-H and O-H bonds lie in the wavelength range of approximately 6-12 microns. However, light sources and detectors are more difficult in the mid-wave infrared and long-wave infrared, and there is also strongly increasing water absorption in the human body beyond about 2.5 microns. Although weaker, there are also non-linear combinations of stretching and bending modes between about 2 to 2.5 microns, and first overtone of C-H stretching modes between approximately 1.5-1.8 microns. These signatures may fall in valleys of water absorption, permitting non-invasive detection through the body. In addition, there are yet weaker features from the second overtones and higher-order combinations between about 0.8-1.2 microns; in addition to being weaker, these features may also be masked by absorption in the hemoglobin. Hence, the short-wave infrared (SWIR) wavelength range of approximately 1.4 to 2.5 microns may be an attractive window for near-infrared spectroscopy of blood constituents.

[0055] As an example, measurements of the optical absorbance 200 of hemoglobin, glucose and HbA1c have been performed using a Fourier-Transform Infrared Spectrometer – FTIR. As FIGURE 2 shows, in the SWIR wavelength range hemoglobin is nearly flat in spectrum 201 (the noise at the edges is due to the weaker light signal in the measurements). On the other hand, the glucose absorbance 202 has at least five distinct peaks near 1587nm, 1750nm, 2120nm, 2270nm and 2320nm.

[0056] FIGURE 3A overlaps 300 the normalized absorbance of glucose 301 with the absorbance of water 302 (not drawn to scale). It may be seen that water has an absorbance feature between approximately 1850nm and 2050nm, but water 302 also has a nice transmission window between approximately 1500-1850nm and 2050 to 2500nm. For wavelengths less than about 1100nm, the absorption of hemoglobin 351 and oxygenated hemoglobin 352 in FIGURE 3B has a number of features 350, which may make it more difficult to measure blood constituents. Also,

beyond 2500nm the water absorption becomes considerably stronger over a wide wavelength range. Therefore, an advantageous window for measuring glucose and other blood constituents may be in the SWIR between 1500 and 1850nm and 2050 to 2500nm. These are exemplary wavelength ranges, and other ranges can be used that would still fall within the scope of this disclosure.

[0057] One further consideration in choosing the laser wavelength is known as the “eye safe” window for wavelengths longer than about 1400nm. In particular, wavelengths in the eye safe window may not transmit down to the retina of the eye, and therefore, these wavelengths may be less likely to create permanent eye damage. The near-infrared wavelengths have the potential to be dangerous, because the eye cannot see the wavelengths (as it can in the visible), yet they can penetrate and cause damage to the eye. Even if a practitioner is not looking directly at the laser beam, the practitioner’s eyes may receive stray light from a reflection or scattering from some surface. Hence, it can always be a good practice to use eye protection when working around lasers. Since wavelengths longer than about 1400nm are substantially not transmitted to the retina or substantially absorbed in the retina, this wavelength range is known as the eye safe window. For wavelengths longer than 1400nm, in general only the cornea of the eye may receive or absorb the light radiation.

[0058] Beyond measuring blood constituents such as glucose using FTIR spectrometers, measurements have also been conducted in another embodiment using super-continuum lasers, which will be described later in this disclosure. In this particular embodiment, some of the exemplary preliminary data for glucose absorbance are illustrated in FIGURES 4A and 4B. The optical spectra 401 in FIGURE 4A for different levels of glucose concentration in the wavelength range between 2000 and 2400nm show the three absorption peaks near 2120nm (2.12 μ m), 2270nm (2.27 μ m) and 2320nm (2.32 μ m). Moreover, the optical spectra 402 in FIGURE 4B for different levels of glucose concentration in the wavelength range between 1500 and 1800nm show the two broader absorption peaks near 1587nm and 1750nm. It should be appreciated that although data measured with FTIR spectrometers or super-continuum lasers have been illustrated, other light sources can also be used to obtain the data, such as super-luminescent laser diodes, light emitting

diodes, a plurality of laser diodes, or even bright lamp sources that generate adequate light in the SWIR.

[0059] Although glucose has a distinctive signature in the SWIR wavelength range, one problem of non-invasive glucose monitoring is that many other blood constituents also have hydro-carbon bonds. Consequently, there can be interfering signals from other constituents in the blood. As an example, FIGURE 5 illustrates the spectrum 500 for different blood constituents in the wavelength range of 2 to 2.45 microns. The glucose absorption spectrum 501 can be unique with its three peaks in this wavelength range. However, other blood constituents such as triacetin 502, ascorbate 503, lactate 504, alanine 505, urea 506, and BSA 507 also have spectral features in this wavelength range. To distinguish the glucose 501 from these overlapping spectra, it may be advantageous to have information at multiple wavelengths. In addition, it may be advantageous to use pattern matching algorithms and other software and mathematical methods to identify the blood constituents of interest. In one embodiment, the spectrum may be correlated with a library of known spectra to determine the overlap integrals, and a threshold function may be used to quantify the concentration of different constituents. This is just one way to perform the signal processing, and many other techniques, algorithms, and software may be used and would fall within the scope of this disclosure.

KETONE BODIES MONITORING

[0060] Beyond glucose, there are many other blood constituents that may also be of interest for health or disease monitoring. In another embodiment, it may be desirable to monitor the level of ketone bodies in the blood stream. Ketone bodies are three water-soluble compounds that are produced as by-products when fatty acids are broken down for energy in the liver. Two of the three are used as a source of energy in the heart and brain, while the third is a waste product excreted from the body. In particular, the three endogenous ketone bodies are acetone, acetoacetic acid, and beta-hydroxybutyrate or 3-hydroxybutyrate, and the waste product ketone body is acetone.

[0061] Ketone bodies may be used for energy, where they are transported from the liver to other tissues. The brain may utilize ketone bodies when sufficient glucose is not available for

energy. For instance, this may occur during fasting, strenuous exercise, low carbohydrate, ketogenic diet and in neonates. Unlike most other tissues that have additional energy sources such as fatty acids during periods of low blood glucose, the brain cannot break down fatty acids and relies instead on ketones. In one embodiment, these ketone bodies are detected.

[0062] Ketone bodies may also be used for reducing or eliminating symptoms of diseases or disorders characterized by impaired glucose metabolism. For example, diseases associated with reduced neuronal metabolism of glucose include Parkinson's disease, Alzheimer's disease, amyotrophic lateral sclerosis (ALS, also called Lou Gehrig's disease), Huntington's disease and epilepsy. In one embodiment, monitoring of alternate sources of ketone bodies that may be administered orally as a dietary supplement or in a nutritional composition to counteract some of the glucose metabolism impairments is performed. However, if ketone bodies supplements are provided, there is also a need to monitor the ketone level in the blood stream. For instance, if elevated levels of ketone bodies are present in the body, this may lead to ketosis; hyperketonemia is also an elevated level of ketone bodies in the blood. In addition, both acetoacetic acid and beta-hydroxybutyric acid are acidic, and, if levels of these ketone bodies are too high, the pH of the blood may drop, resulting in ketoacidosis.

[0063] The general formula for ketones is $C_nH_{2n}O$. In organic chemistry, a ketone is an organic compound with the structure $RC(=O)R'$, where R and R' can be a variety of carbon-containing substituents. It features a carbonyl group (C=O) bonded to two other carbon atoms. Because the ketones contain the hydrocarbon bonds, there might be expected to be features in the SWIR, similar in structure to those found for glucose.

[0064] The infrared spectrum 600 for the ketone 3-hydroxybutyrate is illustrated in FIGURE 6. Just as in glucose, there are significant features in the mid- and long-wave infrared between 6 to 12 microns, but these may be difficult to observe non-invasively. On the other hand, there are some features in the SWIR that may be weaker, but they could potentially be observed non-invasively, perhaps through blood and water.

[0065] The optical spectra 700 for ketones as well as some other blood constituents are exemplified in FIGURE 7 in the wavelength range of 2100nm to 2400nm. In this embodiment, the absorbance for ketones is 701, while the absorbance for glucose is 702. However, there are also features in this wavelength range for other blood constituents, such as urea 703, albumin or blood protein 704, creatinine 705, and nitrite 706. In this wavelength range of 2100 to 2400nm, the features for ketone 701 seem more spectrally pronounced than even glucose.

[0066] Different signal processing techniques can be used to enhance the spectral differences between different constituents. In one embodiment, the first or second derivatives of the spectra may enable better discrimination between substances. The first derivative may help remove any flat offset or background, while the second derivative may help to remove any sloped offset or background. In some instances, the first or second derivative may be applied after curve fitting or smoothing the reflectance, transmittance, or absorbance. For example, FIGURE 8A illustrates the derivative spectra for ketone 801 and glucose 802, which can be distinguished from the derivative spectra for protein 803, urea 804 and creatinine 805. Based on FIGURE 8A, it appears that ketones 801 may have a more pronounced difference than even glucose 802 in the wavelength range between 2100 and 2400nm. Therefore, ketone bodies should also be capable of being monitored using a non-invasive optical technique in the SWIR, and a different pattern matching library could be used for glucose and ketones.

HEMOGLOBIN A1C MONITORING

[0067] Another blood constituent that may be of interest for monitoring of health or diseases is hemoglobin A1c, also known as HbA1c or glycated hemoglobin (glycol-hemoglobin or glycosylated hemoglobin). HbA1c is a form of hemoglobin that is measured primarily to identify the average plasma glucose concentration over prolonged periods of time. Thus, HbA1c may serve as a marker for average blood glucose levels over the previous months prior to the measurements.

[0068] In one embodiment, when a physician suspects that a patient may be diabetic, the measurement of HbA1c may be one of the first tests that are conducted. An HbA1c level less than approximately 6% may be considered normal. On the other hand, an HbA1c level greater than

approximately 6.5% may be considered to be diabetic. In diabetes mellitus, higher amounts of HbA1c indicate poorer control of blood glucose levels. Thus, monitoring the HbA1c in diabetic patients may improve treatment. Current techniques for measuring HbA1c require drawing blood, which may be inconvenient and painful. The point-of-care devices use immunoassay or boronate affinity chromatography, as an example. Thus, there is also an unmet need for non-invasive monitoring of HbA1c.

[0069] FIGURE 2 illustrates the FTIR measurements of HbA1c absorbance 203 over the wavelength range between 1500 and 2400nm for a concentration of approximately 1mg/ml. Whereas the absorbance of hemoglobin 201 over this wavelength range is approximately flat, the HbA1c absorbance 203 shows broad features and distinct curvature. Although the HbA1c absorbance 203 does not appear to exhibit as pronounced features as glucose 202, the non-invasive SWIR measurement should be able to detect HbA1c with appropriate pattern matching algorithms. Moreover, the spectrum for HbA1c may be further enhanced by using first or second derivative data, as seen for ketones in FIGURE 8A. Beyond absorption, reflectance, or transmission spectroscopy, it may also be possible to detect blood constituents such as HbA1c using Raman spectroscopy or surface-enhanced Raman spectroscopy. In general, Raman spectroscopy may require higher optical power levels.

[0070] As an illustration, non-invasive measurement of blood constituents such as glucose, ketone bodies, and HbA1c has been discussed thus far. However, other blood constituents can also be measured using similar techniques, and these are also intended to be covered by this disclosure. In other embodiments, blood constituents such as proteins, albumin, urea, creatinine or nitrites could also be measured. For instance, the same type of SWIR optical techniques might be used, but the pattern matching algorithms and software could use different library features or functions for the different constituents.

[0071] In yet another embodiment, the optical techniques described in this disclosure could also be used to measure levels of triglycerides. Triglycerides are bundles of fats that may be found in the blood stream, particularly after ingesting meals. The body manufactures triglycerides from carbohydrates and fatty foods that are eaten. In other words, triglycerides are the body's storage

form of fat. Triglycerides are comprised of three fatty acids attached to a glycerol molecule, and measuring the level of triglycerides may be important for diabetics. The triglyceride levels or concentrations in blood may be rated as follows: desirable or normal may be less than 150 mg/dl; borderline high may be 150-199 mg/dl; high may be 200-499 mg/dl; and very high may be 500mg/dl or greater. FIGURE 8B illustrates one example of the near-infrared absorbance 825 for triglycerides. There are distinct absorbance peaks in the spectrum that should be measurable. The characteristic absorption bands may be assigned as follows: (a) the first overtones of C-H stretching vibrations (1600-1900nm); (b) the region of second overtones of C-H stretching vibrations (1100-1250nm); and, (c) two regions (2000-2200nm and 1350-1500nm) that comprise bands due to combinations of C-H stretching vibrations and other vibrational modes.

[0072] A further example of blood compositions that can be detected or measured using near-infrared light includes cholesterol monitoring. For example, FIGURE 8C shows the near-infrared reflectance spectrum for cholesterol 850 with wavelength in microns (μm). Distinct absorption peaks are observable near 1210nm (1.21 μm), 1720nm (1.72 μm), and between 2300-2500nm (2.3-2.5 μm). Also, there are other features near 1450nm (1.45 μm) and 2050nm (2.05 μm). In FIGURE 8D the near-infrared reflectances 875 are displayed versus wavelength (nm) for various blood constituents. The spectrum for cholesterol 876 is overlaid with glucose 877, albumin 878, uric acid 879, and urea 880. As may be noted from FIGURE 8D, at about 1720nm and 2300nm, cholesterol 876 reaches approximate reflectance peaks, while some of the other analytes are in a more gradual mode. Various signal processing methods may be used to identify and quantify the concentration of cholesterol 876 and/or glucose 877, or some of the other blood constituents.

[0073] As illustrated by FIGURES 5 and 7, one of the issues in measuring a particular blood constituent is the interfering and overlapping signal from other blood constituents. The selection of the constituent of interest may be improved using a number of techniques. For example, a higher light level or intensity may improve the signal-to-noise ratio for the measurement. Second, mathematical modeling and signal processing methodologies may help to reduce the interference, such as multivariate techniques, multiple linear regression, and factor-based algorithms, for example. For instance, a number of mathematical approaches include multiple linear regression, partial least

squares, and principal component regression (PCR). Also, as illustrated in FIGURE 8A, various mathematical derivatives, including the first and second derivatives, may help to accentuate differences between spectra. In addition, by using a wider wavelength range and using more sampling wavelengths may improve the ability to discriminate one signal from another. These are just examples of some of the methods of improving the ability to discriminate between different constituents, but other techniques may also be used and are intended to be covered by this disclosure.

INTERFERENCE FROM SKIN

[0074] Several proposed non-invasive glucose monitoring techniques rely on transmission, absorption, and/or diffuse reflection through the skin to measure blood constituents or blood analytes in veins, arteries, capillaries or in the tissue itself. However, on top of the interference from other blood constituents or analytes, the skin also introduces significant interference. For example, chemical, structural, and physiological variations occur that may produce relatively large and nonlinear changes in the optical properties of the tissue sample. In one embodiment, the near-infrared reflectance or absorbance spectrum may be a complex combination of the tissue scattering properties that result from the concentration and characteristics of a multiplicity of tissue components including water, fat, protein, collagen, elastin, and/or glucose. Moreover, the optical properties of the skin may also change with environmental factors such as humidity, temperature and pressure. Physiological variation may also cause changes in the tissue measurement over time and may vary based on lifestyle, health, aging, etc. The structure and composition of skin may also vary widely among individuals, between different sites within an individual, and over time on the same individual. Thus, the skin introduces a dynamic interference signal that may have a wide variation due to a number of parameters.

[0075] FIGURE 9 shows a schematic cross-section of human skin 900, 901. The top layer of the skin is epidermis 902, followed by a layer of dermis 903 and then subcutaneous fat 904 below the dermis. The epidermis 902, with a thickness of approximately 10-150 microns, may provide a barrier to infection and loss of moisture and other body constituents. The dermis 903 ranges in

thickness from approximately 0.5mm to 4mm (averages approximately 1.2mm over most of the body) and may provide the mechanical strength and elasticity of skin.

[0076] In the dermis 903, water may account for approximately 70% of the volume. The next most abundant constituent in the dermis 903 may be collagen 905, a fibrous protein comprising 70-75% of the dry weight of the dermis 903. Elastin fibers 906, also a protein, may also be plentiful in the dermis 903, although they constitute a smaller portion of the bulk. In addition, the dermis 903 may contain a variety of structures (e.g., sweat glands, hair follicles with adipose rich sebaceous glands 907 near their roots, and blood vessels) and other cellular constituents.

[0077] Below the dermis 903 lies the subcutaneous layer 904 comprising mostly adipose tissue. The subcutaneous layer 904 may be by volume approximately 10% water and may be comprised primarily of cells rich in triglycerides or fat. With this complicated structure of the skin 900,901, the concentration of glucose may vary in each layer according to a variety of factors including the water content, the relative sizes of the fluid compartments, the distribution of capillaries, the perfusion of blood, the glucose uptake of cells, the concentration of glucose in blood, and the driving forces (e.g., osmotic pressure) behind diffusion.

[0078] To better understand the interference that the skin introduces when attempting to measure glucose, the absorption coefficient for the various skin constituents should be examined. For example, FIGURE 10 illustrates 1000 the absorption coefficients for water (including scattering) 1001, adipose 1002, collagen 1003 and elastin 1004. Note that the absorption curves for water 1001 and adipose 1002 are calibrated, whereas the absorption curves for collagen 1003 and elastin 1004 are in arbitrary units. Also shown are vertical lines demarcating the wavelengths near 1210nm 1005 and 1720nm 1006. In general, the water absorption increases with increasing wavelength. With the increasing absorption beyond about 2000nm, it may be difficult to achieve deeper penetration into biological tissue in the infrared wavelengths beyond approximately 2500nm.

[0079] Although the absorption coefficient may be useful for determining the material in which light of a certain infrared wavelength will be absorbed, to determine the penetration depth of the light of a certain wavelength may also require the addition of scattering loss to the curves. For

example, the water curve 1001 includes the scattering loss curve in addition to the water absorption. In particular, the scattering loss can be significantly higher at shorter wavelengths. In one embodiment, near the wavelength of 1720nm (vertical line 1006 shown in FIGURE 10), the adipose absorption 1002 can still be higher than the water plus scattering loss 1001. For tissue that contains adipose, collagen and elastin, such as the dermis of the skin, the total absorption can exceed the light energy lost to water absorption and light scattering at 1720nm. On the other hand, at 1210nm the adipose absorption 1002 can be considerably lower than the water plus scattering loss 1001, particularly since the scattering loss can be dominant at these shorter wavelengths.

[0080] The interference for glucose lines observed through skin may be illustrated by overlaying the glucose lines over the absorption curves 1000 for the skin constituents. For example, FIGURE 2 illustrated that the glucose absorption 202 included features centered around 1587nm, 1750nm, 2120nm, 2270nm and 2320nm. On FIGURE 10 vertical lines have been drawn at the glucose line wavelengths of 1587nm 1007, 1750nm 1008, 2120nm 1009, 2270nm 1010 and 2320nm 1011. In one embodiment, it may be difficult to detect the glucose lines near 1750nm 1008, 2270nm 1010 and 2320nm 1011 due to significant spectral interference from other skin constituents. On the other hand, the glucose line near 1587m 1007 may be more easily detected because it peaks while most of the other skin constituents are sloped downward toward an absorption valley. Moreover, the glucose line near 2120nm 1009 may also be detectable for similar reasons, although adipose may have conflicting behavior due to local absorption minimum and maximum nearby in wavelength.

[0081] Thus, beyond the problem of other blood constituents or analytes having overlapping spectral features (e.g., FIGURE 5), it may be difficult to observe glucose spectral signatures through the skin and its constituents of water, adipose, collagen and elastin. One approach to overcoming this difficulty may be to try to measure the blood constituents in veins that are located at relatively shallow distances below the skin. Veins may be more beneficial for the measurement than arteries, since arteries tend to be located at deeper levels below the skin. Also, in one embodiment it may be advantageous to use a differential measurement to subtract out some of the interfering absorption lines from the skin. For example, an instrument head may be designed to place one probe above a region of skin over a blood vein, while a second probe may be placed at a region of the skin without

a noticeable blood vein below it. Then, by differencing the signals from the two probes, at least part of the skin interference may be cancelled out.

[0082] Two representative embodiments for performing such a differential measurement are illustrated in FIGURE 11 and FIGURE 12. In one embodiment shown in FIGURE 11, the dorsal of the hand 1100 may be used for measuring blood constituents or analytes. The dorsal of the hand 1100 may have regions that have distinct veins 1101 as well as regions where the veins are not as shallow or pronounced 1102. By stretching the hand and leaning it backwards, the veins 1101 may be accentuated in some cases. A near-infrared diffuse reflectance measurement may be performed by placing one probe 1103 above the vein-rich region 1101. To turn this into a differential measurement, a second probe 1104 may be placed above a region without distinct veins 1102. Then, the outputs from the two probes may be subtracted 1105 to at least partially cancel out the features from the skin. The subtraction may be done preferably in the electrical domain, although it can also be performed in the optical domain or digitally/mathematically using sampled data based on the electrical and/or optical signals. Although one example of using the dorsal of the hand 1100 is shown, many other parts of the hand can be used within the scope of this disclosure. For example, alternate methods may use transmission through the webbing between the thumb and the fingers 1106, or transmission or diffuse reflection through the tips of the fingers 1107.

[0083] In another embodiment, the dorsal of the foot 1200 may be used instead of the hand. One advantage of such a configuration may be that for self-testing by a user, the foot may be easier to position the instrument using both hands. One probe 1203 may be placed over regions where there are more distinct veins 1201, and a near-infrared diffuse reflectance measurement may be made. For a differential measurement, a second probe 1204 may be placed over a region with less prominent veins 1202, and then the two probe signals may be subtracted, either electronically or optically, or may be digitized/sampled and processed mathematically depending on the particular application and implementation. As with the hand, the differential measurements may be intended to compensate for or subtract out (at least in part) the interference from the skin. Since two regions are used in close proximity on the same body part, this may also aid in removing some variability in the skin from environmental effects such as temperature, humidity, or pressure. In addition, it may be

advantageous to first treat the skin before the measurement, by perhaps wiping with a cloth or treated cotton ball, applying some sort of cream, or placing an ice cube or chilled bag over the region of interest.

[0084] Although two embodiments have been described, many other locations on the body may be used using a single or differential probe within the scope of this disclosure. In yet another embodiment, the wrist may be advantageously used, particularly where a pulse rate is typically monitored. Since the pulse may be easily felt on the wrist, there is underlying the region a distinct blood flow. Other embodiments may use other parts of the body, such as the ear lobes, the tongue, the inner lip, the nails, the eye, or the teeth. Some of these embodiments will be further described below. The ear lobes or the tip of the tongue may be advantageous because they are thinner skin regions, thus permitting transmission rather than diffuse reflection. However, the interference from the skin is still a problem in these embodiments. Other regions such as the inner lip or the bottom of the tongue may be contemplated because distinct veins are observable, but still the interference from the skin may be problematic in these embodiments. The eye may seem as a viable alternative because it is more transparent than skin. However, there are still issues with scattering in the eye. For example, the anterior chamber of the eye (the space between the cornea and the iris) comprises a fluid known as aqueous humor. However, the glucose level in the eye chamber may have a significant temporal lag on changes in the glucose level compared to the blood glucose level.

[0085] Because of the complexity of the interference from skin in non-invasive glucose monitoring (e.g., FIGURE 10), other parts of the body without skin above blood vessels or capillaries may be alternative candidates for measuring blood constituents. One embodiment may involve transmission or reflection through human nails. As an example, FIGURE 13 illustrates a typical human nail tissue structure 1300 and the capillary vessels below it. The fingernail 1301 is approximately 1mm thick, and below this resides a layer of epidermis 1302 with a thickness of approximately 1mm. The dermis 1304 is also shown, and within particularly the top about 0.5mm of dermis are a significant number of capillary vessels. To measure the blood constituents, the light exposed on the top of the fingernail must penetrate about 2-2.5mm or more, and the reflected light

(round trip passage) should be sufficiently strong to measure. In one embodiment, the distance required to penetrate could be reduced by drilling a hole in the fingernail 1301.

[0086] In this alternative embodiment using the fingernail, there may still be interference from the nail's spectral features. For example, FIGURE 14 illustrates the attenuation coefficient 1400 for seven nail samples that are allowed to stand in an environment with a humidity level of 14%. These coefficients are measured using an FTIR spectrometer over the near-infrared wavelength range of approximately 1 to 2.5 microns. These spectra are believed to correspond to the spectra of keratin contained in the nail plate. The base lines for the different samples are believed to differ because of the influence of scattering. Several of the absorption peaks observed correspond to peaks of keratin absorption, while other features may appear from the underlying epidermis and dermis. It should also be noted that the attenuation coefficients 1400 also vary considerably depending on humidity level or water content as well as temperature and other environmental factors. Moreover, the attenuation coefficient may also change in the presence of nail polish of various sorts.

[0087] Similar to skin, the large variations in attenuation coefficient for fingernails also may interfere with the absorption peaks of glucose. As an example, in FIGURE 14 below the fingernail spectrum is also shown the glucose spectrum 1401 for two different glucose concentrations. The vertical lines 1402, 1403, 1404, 1405 and 1406 are drawn to illustrate the glucose absorption peaks and where they lie on the fingernail spectra 1400. As is apparent, the nail has interfering features that may be similar to skin, particularly since both have spectra that vary not only in wavelength but also with environmental factors. In one embodiment, it may be possible to see the glucose peaks 1402 and 1404 through the fingernail, but it may be much more difficult to observe the glucose peaks near 1403, 1405 and 1406.

TRANSMISSION OR REFLECTION THROUGH TEETH

[0088] Yet another embodiment may observe the transmittance or reflectance through teeth to measure blood constituents or analytes. FIGURE 15 illustrates an exemplary structure of a tooth 1500. The tooth 1500 has a top layer called the crown 1501 and below that a root 1502 that reaches

well into the gum 1506 and bone 1508 of the mouth. The exterior of the crown 1501 is an enamel layer 1503, and below the enamel is a layer of dentine 1504 that sits atop a layer of cementum 1507. Below the dentine 1504 is a pulp region 1505, which comprises within it blood vessels 1509 and nerves 1510. If the light can penetrate the enamel 1503 and dentine 1504, then the blood flow and blood constituents can be measured through the blood vessels in the dental pulp 1505. While it may be true that the amount of blood flow in the dental pulp 1505 may be less since it comprises capillaries, the smaller blood flow could still be advantageous if there is less interfering spectral features from the tooth.

[0089] The transmission, absorption and reflection from teeth has been studied in the near infrared, and, although there are some features, the enamel and dentine appear to be fairly transparent in the near infrared (particularly wavelengths between 1500 and 2500nm). For example, the absorption or extinction ratio for light transmission has been studied. FIGURE 16A illustrates the attenuation coefficient 1600 for dental enamel 1601 (filled circles) and the absorption coefficient of water 1602 (open circles) versus wavelength. Near-infrared light may penetrate much further without scattering through all the tooth enamel, due to the reduced scattering coefficient in normal enamel. Scattering in enamel may be fairly strong in the visible, but decreases as approximately $1/(\text{wavelength})^3$ [i.e., inverse of the cube of the wavelength] with increasing wavelength to a value of only 2-3 cm^{-1} at 1310nm and 1550nm in the near infrared. Therefore, enamel may be virtually transparent in the near infrared with optical attenuation 1-2 orders of magnitude less than in the visible range.

[0090] As another example, FIGURE 16B illustrates the absorption spectrum 1650 of intact enamel 1651 (dashed line) and dentine 1652 (solid line) in the wavelength range of approximately 1.2 to 2.4 microns. In the near infrared there are two absorption bands around 1.5 and 2 microns. The band with a peak around 1.57 microns may be attributed to the overtone of valent vibration of water present in both enamel and dentine. In this band, the absorption is greater for dentine than for enamel, which may be related to the large water content in this tissue. In the region of 2 microns, dentine may have two absorption bands, and enamel one. The band with a maximum near 2.1 microns may belong to the overtone of vibration of PO hydroxyapatite groups, which is the main

substance of both enamel and dentine. Moreover, the band with a peak near 1.96 microns in dentine may correspond to water absorption (dentine may contain substantially higher water than enamel).

[0091] In addition to the absorption coefficient, the reflectance from intact teeth and teeth with dental caries (e.g., cavities) has been studied. In one embodiment, FIGURE 17 shows the near infrared spectral reflectance 1700 over the wavelength range of approximately 800nm to 2500nm from an occlusal (e.g., top/bottom) tooth surface 1704. The curve with black diamonds 1701 corresponds to the reflectance from a sound, intact tooth section. The curve with asterisks * 1702 corresponds to a tooth section with an enamel lesion. The curve with circles 1703 corresponds to a tooth section with a dentine lesion. Thus, when there is a lesion, more scattering occurs and there may be an increase in the reflected light.

[0092] For wavelengths shorter than approximately 1400nm, the shapes of the spectra remain similar, but the amplitude of the reflection changes with lesions. Between approximately 1400nm and 2500nm, an intact tooth 1701 has low reflectance (e.g., high transmission), and the reflectance appears to be more or less independent of wavelength. On the other hand, in the presence of lesions 1702 and 1703, there is increased scattering, and the scattering loss may be wavelength dependent. For example, the scattering loss may decrease as $1/(\text{wavelength})^3$ -- so, the scattering loss decreases with longer wavelengths. When there is a lesion in the dentine 1703, more water can accumulate in the area, so there is also increased water absorption. For example, the dips near 1450nm and 1900nm correspond to water absorption, and the reflectance dips are particularly pronounced in the dentine lesion 1703. One other benefit of the absorption, transmission or reflectance in the near infrared may be that stains and non-calcified plaque are not visible in this wavelength range, enabling better discrimination of defects, cracks, and demineralized areas.

[0093] Compared with the interference from skin 1000 in FIGURE 10 or fingernails 1400 in FIGURE 14, the teeth appear to introduce much less interference for non-invasive monitoring of blood constituents. The few features in FIGURES 16B or 17 may be calibrated out of the measurement. Also, using an intact tooth 1701 may further minimize any interfering signals. Furthermore, since the tooth comprises relatively hard tissue, higher power from the light sources in the near infrared may be used without damaging the tissue, such as with skin.

HUMAN INTERFACE FOR MEASUREMENT SYSTEM

[0094] A number of different types of measurements may be used to sample the blood in the dental pulp. The basic feature of the measurements should be that the optical properties are measured as a function of wavelength at a plurality of wavelengths. As further described below, the light source may output a plurality of wavelengths, or a continuous spectrum over a range of wavelengths. In a preferred embodiment, the light source may cover some or all of the wavelength range between approximately 1400nm and 2500nm. The signal may be received at a receiver, which may also comprise a spectrometer or filters to discriminate between different wavelengths. The signal may also be received at a camera, which may also comprise filters or a spectrometer. In an alternate embodiment, the spectral discrimination using filters or a spectrometer may be placed after the light source rather than at the receiver. The receiver usually comprises one or more detectors (optical-to-electrical conversion element) and electrical circuitry. The receiver may also be coupled to analog to digital converters, particularly if the signal is to be fed to a digital device.

[0095] Referring to FIGURE 15, one or more light sources 1511 may be used for illumination. In one embodiment, a transmission measurement may be performed by directing the light source output 1511 to the region near the interface between the gum 1506 and dentine 1504. In one embodiment, the light may be directed using a light guide or a fiber optic. The light may then propagate through the dental pulp 1505 to the other side, where the light may be incident on one or more detectors or another light guide to transport the signal to a spectrometer, receiver or camera 1512. In another embodiment, the light source may be directed to one or more locations near the interface between the gum 1506 and dentine 1504 (in one example, could be from the two sides of the tooth). The transmitted light may then be detected in the occlusal surface above the tooth using a spectrometer, receiver, or camera 1512. In yet another embodiment, a reflectance measurement may be conducted by directing the light source output 1511 to, for example, the occlusal surface of the tooth, and then detecting the reflectance at a spectrometer, receiver or camera 1513. Although a few embodiments for measuring the blood constituents through a tooth are described, other embodiments and techniques may also be used and are intended to be covered by this disclosure.

[0096] The human interface for the non-invasive measurement of blood constituents may be of various forms. In one embodiment, a “clamp” design 1800 may be used cap over one or more teeth, as illustrated in FIGURE 18A. The clamp design may be different for different types of teeth, or it may be flexible enough to fit over different types of teeth. For example, different types of teeth include the molars (toward the back of the mouth), the premolars, the canine, and the incisors (toward the front of the mouth). One embodiment of the clamp-type design is illustrated in FIGURE 18A for a molar tooth 1808. The C-clamp 1801 may be made of a plastic or rubber material, and it may comprise a light source input 1802 and a detector output 1803 on the front or back of the tooth.

[0097] The light source input 1802 may comprise a light source directly, or it may have light guided to it from an external light source. Also, the light source input 1802 may comprise a lens system to collimate or focus the light across the tooth. The detector output 1803 may comprise a detector directly, or it may have a light guide to transport the signal to an external detector element. The light source input 1802 may be coupled electrically or optically through 1804 to a light input 1806. For example, if the light source is external in 1806, then the coupling element 1804 may be a light guide, such as a fiber optic. Alternately, if the light source is contained in 1802, then the coupling element 1804 may be electrical wires connecting to a power supply in 1806. Similarly, the detector output 1803 may be coupled to a detector output unit 1807 with a coupling element 1805, which may be one or more electrical wires or a light guide, such as a fiber optic. This is just one example of a clamp over one or more teeth, but other embodiments may also be used and are intended to be covered by this disclosure.

[0098] In yet another embodiment, one or more light source ports and sensor ports may be used in a mouth-guard type design. For example, one embodiment of a dental mouth guard 1850 is illustrated in FIGURE 18B. The structure of the mouth guard 1851 may be similar to mouth guards used in sports (e.g., when playing football or boxing) or in dental trays used for applying fluoride treatment, and the mouth guard may be made from plastic or rubber materials, for example. As an example, the mouth guard may have one or more light source input ports 1852, 1853 and one or more detector output ports 1854, 1855. Although six input and output ports are illustrated, any number of ports may be used.

[0099] Similar to the clamp design describe above, the light source inputs 1852, 1853 may comprise one or more light sources directly, or they may have light guided to them from an external light source. Also, the light source inputs 1852, 1853 may comprise lens systems to collimate or focus the light across the teeth. The detector outputs 1854, 1855 may comprise one or more detectors directly, or they may have one or more light guides to transport the signals to an external detector element. The light source inputs 1852, 1853 may be coupled electrically or optically through 1856 to a light input 1857. For example, if the light source is external in 1857, then the one or more coupling elements 1856 may be one or more light guides, such as a fiber optic. Alternately, if the light sources are contained in 1852, 1853, then the coupling element 1856 may be one or more electrical wires connecting to a power supply in 1857. Similarly, the detector outputs 1854, 1855 may be coupled to a detector output unit 1859 with one or more coupling elements 1858, which may be one or more electrical wires or one or more light guides, such as a fiber optic. This is just one example of a mouth guard design covering a plurality of teeth, but other embodiments may also be used and are intended to be covered by this disclosure. For instance, the position of the light source inputs and detector output ports could be exchanged, or some mixture of locations of light source inputs and detector output ports could be used.

[0100] Other elements may be added to the human interface designs of FIGURE 18 and are also intended to be covered by this disclosure. For instance, in one embodiment it may be desirable to have replaceable inserts that may be disposable. Particularly in a doctor's office or hospital setting, the same instrument may be used with a plurality of patients. Rather than disinfecting the human interface after each use, it may be preferable to have disposable inserts that can be thrown away after each use. In one embodiment, a thin plastic coating material may enclose the clamp design of FIGURE 18A or mouth guard design of FIGURE 18B. The coating material may be inserted before each use, and then after the measurement is exercised the coating material may be peeled off and replaced. Such a design may save the physician or user considerable time, while at the same time provide the business venture with a recurring cost revenue source. Any coating material or other disposable device may be constructed of a material having suitable optical properties that may be considered during processing of the signals used to detect any anomalies in the teeth.

LIGHT SOURCES FOR NEAR INFRARED

[0101] There are a number of light sources that may be used in the near infrared. To be more specific, the discussion below will consider light sources operating in the so-called short wave infrared (SWIR), which may cover the wavelength range of approximately 1400nm to 2500nm. Other wavelength ranges may also be used for the applications described in this disclosure, so the discussion below is merely provided for exemplary types of light sources. The SWIR wavelength range may be valuable for a number of reasons. First, the SWIR corresponds to a transmission window through water and the atmosphere. For example, 302 in FIGURE 3A and 1602 in FIGURE 16A illustrate the water transmission windows. Also, through the atmosphere, wavelengths in the SWIR have similar transmission windows due to water vapor in the atmosphere. Second, the so-called “eye-safe” wavelengths are wavelengths longer than approximately 1400nm. Third, the SWIR covers the wavelength range for nonlinear combinations of stretching and bending modes as well as the first overtone of C-H stretching modes. Thus, for example, glucose and ketones among other substances may have unique signatures in the SWIR. Moreover, many solids have distinct spectral signatures in the SWIR, so particular solids may be identified using stand-off detection or remote sensing. For instance, many explosives have unique signatures in the SWIR.

[0102] Different light sources may be selected for the SWIR based on the needs of the application. Some of the features for selecting a particular light source include power or intensity, wavelength range or bandwidth, spatial or temporal coherence, spatial beam quality for focusing or transmission over long distance, and pulse width or pulse repetition rate. Depending on the application, lamps, light emitting diodes (LEDs), laser diodes (LD's), tunable LD's, superluminescent laser diodes (SLDs), fiber lasers or super-continuum sources (SC) may be advantageously used. Also, different fibers may be used for transporting the light, such as fused silica fibers, plastic fibers, mid-infrared fibers (e.g., tellurite, chalcogenides, fluorides, ZBLAN, etc), or a hybrid of these fibers.

[0103] Lamps may be used if low power or intensity of light is required in the SWIR, and if an incoherent beam is suitable. In one embodiment, in the SWIR an incandescent lamp that can be

used is based on tungsten and halogen, which have an emission wavelength between approximately 500nm to 2500nm. For low intensity applications, it may also be possible to use thermal sources, where the SWIR radiation is based on the black body radiation from the hot object. Although the thermal and lamp based sources are broadband and have low intensity fluctuations, it may be difficult to achieve a high signal-to-noise ratio in a non-invasive blood constituent measurement due to the low power levels. Also, the lamp based sources tend to be energy inefficient.

[0104] In another embodiment, LED's can be used that have a higher power level in the SWIR wavelength range. LED's also produce an incoherent beam, but the power level can be higher than a lamp and with higher energy efficiency. Also, the LED output may more easily be modulated, and the LED provides the option of continuous wave or pulsed mode of operation. LED's are solid state components that emit a wavelength band that is of moderate width, typically between about 20nm to 40nm. There are also so-called super-luminescent LEDs that may even emit over a much wider wavelength range. In another embodiment, a wide band light source may be constructed by combining different LEDs that emit in different wavelength bands, some of which could preferably overlap in spectrum. One advantage of LEDs as well as other solid state components is the compact size that they may be packaged into.

[0105] In yet another embodiment, various types of laser diodes may be used in the SWIR wavelength range. Just as LEDs may be higher in power but narrower in wavelength emission than lamps and thermal sources, the LDs may be yet higher in power but yet narrower in wavelength emission than LEDs. Different kinds of LDs may be used, including Fabry-Perot LDs, distributed feedback (DFB) LDs, distributed Bragg reflector (DBR) LDs. Since the LDs have relatively narrow wavelength range (typically under 10nm), in one embodiment a plurality of LDs may be used that are at different wavelengths in the SWIR. For example, in a preferred embodiment for non-invasive glucose monitoring, it may be advantageous to use LDs having emission spectra near some or all of the glucose spectral peaks (e.g., near 1587nm, 1750nm, 2120nm, 2270nm, and 2320nm). The various LDs may be spatially multiplexed, polarization multiplexed, wavelength multiplexed, or a combination of these multiplexing methods. Also, the LDs may be fiber pig-tailed or have one or more lenses on the output to collimate or focus the light. Another advantage of LDs is that they may

be packaged compactly and may have a spatially coherent beam output. Moreover, tunable LDs that can tune over a range of wavelengths are also available. The tuning may be done by varying the temperature, or electrical current may be used in particular structures, such as distributed Bragg reflector LDs. In another embodiment, external cavity LDs may be used that have a tuning element, such as a fiber grating or a bulk grating, in the external cavity.

[0106] In another embodiment, super-luminescent laser diodes may provide higher power as well as broad bandwidth. An SLD is typically an edge emitting semiconductor light source based on super-luminescence (e.g., this could be amplified spontaneous emission). SLDs combine the higher power and brightness of LDs with the low coherence of conventional LEDs, and the emission band for SLD's may be 5 to 100nm wide, preferably in the 60 to 100nm range. Although currently SLDs are commercially available in the wavelength range of approximately 400nm to 1700nm, SLDs could and may in the future be made to cover a broader region of the SWIR.

[0107] In yet another embodiment, high power LDs for either direct excitation or to pump fiber lasers and SC light sources may be constructed using one or more laser diode bar stacks. As an example, FIGURE 19 shows an example of the block diagram 1900 or building blocks for constructing the high power LDs. In this embodiment, one or more diode bar stacks 1901 may be used, where the diode bar stack may be an array of several single emitter LDs. Since the fast axis (e.g., vertical direction) may be nearly diffraction limited while the slow-axis (e.g., horizontal axis) may be far from diffraction limited, different collimators 1902 may be used for the two axes.

[0108] Then, the brightness may be increased by spatially combining the beams from multiple stacks 1903. The combiner may include spatial interleaving, it may include wavelength multiplexing, or it may involve a combination of the two. Different spatial interleaving schemes may be used, such as using an array of prisms or mirrors with spacers to bend one array of beams into the beam path of the other. In another embodiment, segmented mirrors with alternate high-reflection and anti-reflection coatings may be used. Moreover, the brightness may be increased by polarization beam combining 1904 the two orthogonal polarizations, such as by using a polarization beam splitter. In one embodiment, the output may then be focused or coupled into a large diameter core fiber. As an example, typical dimensions for the large diameter core fiber range from

approximately 100 microns in diameter to 400 microns or more. Alternatively or in addition, a custom beam shaping module 1905 may be used, depending on the particular application. For example, the output of the high power LD may be used directly 1906, or it may be fiber coupled 1907 to combine, integrate, or transport the high power LD energy. These high power LDs may grow in importance because the LD powers can rapidly scale up. For example, instead of the power being limited by the power available from a single emitter, the power may increase in multiples depending on the number of diodes multiplexed and the size of the large diameter fiber. Although FIGURE 19 is shown as one embodiment, some or all of the elements may be used in a high power LD, or additional elements may also be used.

SWIR SUPER-CONTINUUM LASERS

[0109] Each of the light sources described above have particular strengths, but they also may have limitations. For example, there is typically a trade-off between wavelength range and power output. Also, sources such as lamps, thermal sources, and LEDs produce incoherent beams that may be difficult to focus to a small area and may have difficulty propagating for long distances. An alternative source that may overcome some of these limitations is an SC light source. Some of the advantages of the SC source may include high power and intensity, wide bandwidth, spatially coherent beam that can propagate nearly transform limited over long distances, and easy compatibility with fiber delivery.

[0110] Supercontinuum lasers may combine the broadband attributes of lamps with the spatial coherence and high brightness of lasers. By exploiting a modulational instability initiated supercontinuum (SC) mechanism, an all-fiber-integrated SC laser with no moving parts may be built using commercial-off-the-shelf (COTS) components. Moreover, the fiber laser architecture may be a platform where SC in the visible, near-infrared / SWIR, or mid-IR can be generated by appropriate selection of the amplifier technology and the SC generation fiber. But until now, SC lasers were used primarily in laboratory settings since typically large, table-top, mode-locked lasers were used to pump nonlinear media such as optical fibers to generate SC light. However, those large pump lasers

may now be replaced with diode lasers and fiber amplifiers that gained maturity in the telecommunications industry.

[0111] In one embodiment, an all-fiber-integrated, high-powered SC light source 2000 may be elegant for its simplicity (FIGURE 20). The light may be first generated from a seed laser diode 2001. For example, the seed LD 2001 may be a distributed feedback laser diode with a wavelength near 1542 or 1550 nm, with approximately 0.5–2.0 ns pulsed output, and with a pulse repetition rate between a kilohertz to about 100MHz or more. The output from the seed laser diode may then be amplified in a multiple-stage fiber amplifier 2002 comprising one or more gain fiber segments. In one embodiment, the first stage pre-amplifier 2003 may be designed for optimal noise performance. For example, the pre-amplifier 2003 may be a standard erbium-doped fiber amplifier or an erbium/ytterbium doped cladding pumped fiber amplifier. Between amplifier stages 2003 and 2006, it may be advantageous to use band-pass filters 2004 to block amplified spontaneous emission and isolators 2005 to prevent spurious reflections. Then, the power amplifier stage 2006 may use a cladding-pumped fiber amplifier that may be optimized to minimize nonlinear distortion. The power amplifier fiber 2006 may also be an erbium-doped fiber amplifier, if only low or moderate power levels are to be generated.

[0112] The SC generation 2007 may occur in the relatively short lengths of fiber that follow the pump laser. In one exemplary embodiment, the SC fiber length may range from a few millimeters to 100m or more. In one embodiment, the SC generation may occur in a first fiber 2008 where the modulational-instability initiated pulse break-up primarily occurs, followed by a second fiber 2009 where the SC generation and spectral broadening primarily occurs.

[0113] In one embodiment, one or two meters of standard single-mode fiber (SMF) after the power amplifier stage may be followed by several meters of SC generation fiber. For this example, in the SMF the peak power may be several kilowatts and the pump light may fall in the anomalous group-velocity dispersion regime—often called the soliton regime. For high peak powers in the dispersion regime, the nanosecond pulses may be unstable due to a phenomenon known as modulational instability, which is basically parametric amplification in which the fiber nonlinearity helps to phase match the pulses. As a consequence, the nanosecond pump pulses may be broken into

many shorter pulses as the modulational instability tries to form soliton pulses from the quasi-continuous-wave background. Although the laser diode and amplification process starts with approximately nanosecond-long pulses, modulational instability in the short length of SMF fiber may form approximately 0.5 ps to several-picosecond-long pulses with high intensity. Thus, the few meters of SMF fiber may result in an output similar to that produced by mode-locked lasers, except in a much simpler and cost-effective manner.

[0114] The short pulses created through modulational instability may then be coupled into a nonlinear fiber for SC generation. The nonlinear mechanisms leading to broadband SC may include four-wave mixing or self-phase modulation along with the optical Raman effect. Since the Raman effect is self-phase-matched and shifts light to longer wavelengths by emission of optical photons, the SC may spread to longer wavelengths very efficiently. The short-wavelength edge may arise from four-wave mixing, and often times the short wavelength edge may be limited by increasing group-velocity dispersion in the fiber. In many instances, if the particular fiber used has sufficient peak power and SC fiber length, the SC generation process may fill the long-wavelength edge up to the transmission window.

[0115] Mature fiber amplifiers for the power amplifier stage 2006 include ytterbium-doped fibers (near 1060 nm), erbium-doped fibers (near 1550nm), erbium/ytterbium-doped fibers (near 1550 nm), or thulium-doped fibers (near 2000 nm). In various embodiments, candidates for SC fiber 2009 include fused silica fibers (for generating SC between 0.8–2.7 μm), mid-IR fibers such as fluorides, chalcogenides, or tellurites (for generating SC out to 4.5 μm or longer), photonic crystal fibers (for generating SC between 0.4 and 1.7 μm), or combinations of these fibers. Therefore, by selecting the appropriate fiber-amplifier doping for 2006 and nonlinear fiber 2009, SC may be generated in the visible, near-IR / SWIR, or mid-IR wavelength region.

[0116] The configuration 2000 of FIGURE 20 is just one particular example, and other configurations can be used and are intended to be covered by this disclosure. For example, further gain stages may be used, and different types of lossy elements or fiber taps may be used between the amplifier stages. In another embodiment, the SC generation may occur partially in the amplifier fiber and in the pig-tails from the pump combiner or other elements. In yet another embodiment,

polarization maintaining fibers may be used, and a polarizer may also be used to enhance the polarization contrast between amplifier stages. Also, not discussed in detail are many accessories that may accompany this set-up, such as driver electronics, pump laser diodes, safety shut-offs, and thermal management and packaging.

[0117] One example of an SC laser that operates in the SWIR used in one embodiment is illustrated in FIGURE 21. This SWIR SC source 2100 produces an output of up to approximately 5W over a spectral range of about 1.5 to 2.4 microns, and this particular laser is made out of polarization maintaining components. The seed laser 2101 is a distributed feedback (DFB) laser operating near 1542nm producing approximately 0.5nanosecond (ns) pulses at an about 8MHz repetition rate. The pre-amplifier 2102 is forward pumped and uses about 2m length of erbium/ytterbium cladding pumped fiber 2103 (often also called dual-core fiber) with an inner core diameter of 12 microns and outer core diameter of 130 microns. The pre-amplifier gain fiber 2103 is pumped using a 10W 940nm laser diode 2105 that is coupled in using a fiber combiner 2104.

[0118] In this particular 5W unit, the mid-stage between amplifier stages 2102 and 2106 comprises an isolator 2107, a band-pass filter 2108, a polarizer 2109 and a fiber tap 2110. The power amplifier 2106 uses a 4m length of the 12/130 micron erbium/ytterbium doped fiber 2111 that is counter-propagating pumped using one or more 30W 940nm laser diodes 2112 coupled in through a combiner 2113. An approximately 1-2 meter length of the combiner pig-tail helps to initiate the SC process, and then a length of PM-1550 fiber 2115 (polarization maintaining, single-mode, fused silica fiber optimized for 1550nm) is spliced 2114 to the combiner output.

[0119] If an output fiber of about 10m in length is used, then the resulting output spectrum 2200 is shown in FIGURE 22. The details of the output spectrum 2200 depend on the peak power into the fiber, the fiber length, and properties of the fiber such as length and core size, as well as the zero dispersion wavelength and the dispersion properties. For example, if a shorter length of fiber is used, then the spectrum actually reaches to longer wavelengths (e.g., a 2m length of SC fiber broadens the spectrum to ~2500nm). Also, if extra-dry fibers are used with less O-H content, then the wavelength edge may also reach to a longer wavelength. To generate more spectrum toward the shorter wavelengths, the pump wavelength (in this case ~1542nm) should be close to the zero

dispersion wavelength in the fiber. For example, by using a dispersion shifted fiber or so-called non-zero dispersion shifted fiber, the short wavelength edge may shift to shorter wavelengths.

[0120] Although one particular example of a 5W SWIR-SC has been described, different components, different fibers, and different configurations may also be used consistent with this disclosure. For instance, another embodiment of the similar configuration 2100 in FIGURE 21 may be used to generate high powered SC between approximately 1060 and 1800nm. For this embodiment, the seed laser 2101 may be a 1064nm distributed feedback (DFB) laser diode, the pre-amplifier gain fiber 2103 may be a ytterbium-doped fiber amplifier with 10/125 microns dimensions, and the pump laser 2105 may be a 10W 915nm laser diode. In the mid-stage, a mode field adapter may be included in addition to the isolator 2107, band pass filter 2108, polarizer 2109 and tap 2110. The gain fiber 2111 in the power amplifier may be a 20m length of ytterbium-doped fiber with 25/400 microns dimension for example. The pump 2112 for the power amplifier may be up to six pump diodes providing 30W each near 915nm, for example. For this much pump power, the output power in the SC may be as high as 50W or more.

[0121] In another embodiment, it may be desirable to generate high power SWIR SC over 1.4-1.8 microns and separately 2-2.5 microns (the window between 1.8 and 2 microns may be less important due to the strong water and atmospheric absorption). For example, the top SC source of FIGURE 23 can lead to bandwidths ranging from about 1400nm to 1800nm or broader, while the lower SC source of FIGURE 23 can lead to bandwidths ranging from about 1900nm to 2500nm or broader. Since these wavelength ranges are shorter than about 2500nm, the SC fiber can be based on fused silica fiber. Exemplary SC fibers include standard single-mode fiber SMF, high-nonlinearity fiber, high-NA fiber, dispersion shifted fiber, dispersion compensating fiber, and photonic crystal fibers. Non-fused-silica fibers can also be used for SC generation, including chalcogenides, fluorides, ZBLAN, tellurites, and germanium oxide fibers.

[0122] In one embodiment, the top of FIGURE 23 illustrates a block diagram for an SC source 2300 capable of generating light between approximately 1400 and 1800nm or broader. As an example, a pump fiber laser similar to FIGURE 21 can be used as the input to a SC fiber 2309. The seed laser diode 2301 can comprise a DFB laser that generates, for example, several milliwatts of

power around 1542 or 1553nm. The fiber pre-amplifier 2302 can comprise an erbium-doped fiber amplifier or an erbium/ytterbium doped double clad fiber. In this example a mid-stage amplifier 2303 can be used, which can comprise an erbium/ytterbium doped double-clad fiber. A bandpass filter 2305 and isolator 2306 may be used between the pre-amplifier 2302 and mid-stage amplifier 2303. The power amplifier stage 2304 can comprise a larger core size erbium/ytterbium doped double-clad fiber, and another bandpass filter 2307 and isolator 2308 can be used before the power amplifier 2304. The output of the power amplifier can be coupled to the SC fiber 2309 to generate the SC output 2310. This is just one exemplary configuration for an SC source, and other configurations or elements may be used consistent with this disclosure.

[0123] In yet another embodiment, the bottom of FIGURE 23 illustrates a block diagram for an SC source 2350 capable of generating light between approximately 1900 and 2500nm or broader. As an example, the seed laser diode 2351 can comprise a DFB or DBR laser that generates, for example, several milliwatts of power around 1542 or 1553nm. The fiber pre-amplifier 2352 can comprise an erbium-doped fiber amplifier or an erbium/ytterbium doped double-clad fiber. In this example a mid-stage amplifier 2353 can be used, which can comprise an erbium/ytterbium doped double-clad fiber. A bandpass filter 2355 and isolator 2356 may be used between the pre-amplifier 2352 and mid-stage amplifier 2353. The power amplifier stage 2354 can comprise a thulium doped double-clad fiber, and another isolator 2357 can be used before the power amplifier 2354. Note that the output of the mid-stage amplifier 2353 can be approximately near 1550nm, while the thulium-doped fiber amplifier 2354 can amplify wavelengths longer than approximately 1900nm and out to about 2100nm. Therefore, for this configuration wavelength shifting may be required between 2353 and 2354. In one embodiment, the wavelength shifting can be accomplished using a length of standard single-mode fiber 2358, which can have a length between approximately 5 and 50 meters, for example. The output of the power amplifier 2354 can be coupled to the SC fiber 2359 to generate the SC output 2360. This is just one exemplary configuration for an SC source, and other configurations or elements can be used consistent with this disclosure. For example, the various amplifier stages can comprise different amplifier types, such as erbium doped fibers, ytterbium doped fibers, erbium/ytterbium co-doped fibers and thulium doped fibers. One advantage of the SC lasers illustrated in FIGURES 20-23 are that they may use all-fiber components, so that the SC laser

can be all-fiber, monolithically integrated with no moving parts. The all-integrated configuration can consequently be robust and reliable.

[0124] FIGURES 20-23 are examples of SC light sources that may be advantageously used for SWIR light generation in various medical diagnostic and therapeutic applications. However, many other versions of the SC light sources may also be made that are intended to also be covered by this disclosure. For example, the SC generation fiber could be pumped by a mode-locked laser, a gain-switched semiconductor laser, an optically pumped semiconductor laser, a solid state laser, other fiber lasers, or a combination of these types of lasers. Also, rather than using a fiber for SC generation, either a liquid or a gas cell might be used as the nonlinear medium in which the spectrum is to be broadened.

[0125] Even within the all-fiber versions illustrated such as in FIGURE 21, different configurations could be used consistent with the disclosure. In an alternate embodiment, it may be desirable to have a lower cost version of the SWIR SC laser of FIGURE 21. One way to lower the cost could be to use a single stage of optical amplification, rather than two stages, which may be feasible if lower output power is required or the gain fiber is optimized. For example, the pre-amplifier stage 2102 might be removed, along with at least some of the mid-stage elements. In yet another embodiment, the gain fiber could be double passed to emulate a two stage amplifier. In this example, the pre-amplifier stage 2102 might be removed, and perhaps also some of the mid-stage elements. A mirror or fiber grating reflector could be placed after the power amplifier stage 2106 that may preferentially reflect light near the wavelength of the seed laser 2101. If the mirror or fiber grating reflector can transmit the pump light near 940nm, then this could also be used instead of the pump combiner 2113 to bring in the pump light 2112. The SC fiber 2115 could be placed between the seed laser 2101 and the power amplifier stage 2106 (SC is only generated after the second pass through the amplifier, since the power level may be sufficiently high at that time). In addition, an output coupler may be placed between the seed laser diode 2101 and the SC fiber, which now may be in front of the power amplifier 2106. In a particular embodiment, the output coupler could be a power coupler or divider, a dichroic coupler (e.g., passing seed laser wavelength but outputting the SC wavelengths), or a wavelength division multiplexer coupler. This is just one further example, but

a myriad of other combinations of components and architectures could also be used for SC light sources to generate SWIR light that are intended to be covered by this disclosure.

WIRELESS LINK TO THE CLOUD

[0126] The non-invasive blood constituent or analytes measurement device may also benefit from communicating the data output to the “cloud” (e.g., data servers and processors in the web remotely connected) via wired and/or wireless communication strategies. The non-invasive devices may be part of a series of biosensors applied to the patient, and collectively these devices form what might be called a body area network or a personal area network. The biosensors and non-invasive devices may communicate to a smart phone, tablet, personal data assistant, computer, and/or other microprocessor-based device, which may in turn wirelessly or over wire and/or fiber optically transmit some or all of the signal or processed data to the internet or cloud. The cloud or internet may in turn send the data to doctors or health care providers as well as the patients themselves. Thus, it may be possible to have a panoramic, high-definition, relatively comprehensive view of a patient that doctors can use to assess and manage disease, and that patients can use to help maintain their health and direct their own care.

[0127] In a particular embodiment 2400, the physiological measurement device or non-invasive blood constituent measurement device 2401 may comprise a transmitter 2403 to communicate over a first communication link 2404 in the body area network or personal area network to a receiver in a smart phone, tablet cell phone, PDA, or computer 2405. For the measurement device 2401, it may also be advantageous to have a processor 2402 to process some of the physiological data, since with processing the amount of data to transmit may be less (hence, more energy efficient). The first communication link 2404 may operate through the use of one of many wireless technologies such as Bluetooth, Zigbee, WiFi, IrDA (infrared data association), wireless USB, or Z-wave, to name a few. Alternatively, the communication link 2404 may occur in the wireless medical band between 2360 and 2390MHz, which the FCC allocated for medical body area network devices, or in other designated medical device or WMTS bands. These are examples

of devices that can be used in the body area network and surroundings, but other devices could also be used and are included in the scope of this disclosure.

[0128] The personal device 2405 may store, process, display, and transmit some of the data from the measurement device 2401. The device 2405 may comprise a receiver, transmitter, display, voice control and speakers, and one or more control buttons or knobs and a touch screen. Examples of the device 2405 include smart phones such as the Apple iPhones® or phones operating on the Android or Microsoft systems. In one embodiment, the device 2405 may have an application, software program, or firmware to receive and process the data from the measurement device 2401. The device 2405 may then transmit some or all of the data or the processed data over a second communication link 2406 to the internet or “cloud” 2407. The second communication link 2406 may advantageously comprise at least one segment of a wireless transmission link, which may operate using WiFi or the cellular network. The second communication link 2406 may additionally comprise lengths of fiber optic and/or communication over copper wires or cables.

[0129] The internet or cloud 2407 may add value to the measurement device 2401 by providing services that augment the physiological data collected. In a particular embodiment, some of the functions performed by the cloud include: (a) receive at least a fraction of the data from the device 2405; (b) buffer or store the data received; (c) process the data using software stored on the cloud; (d) store the resulting processed data; and (e) transmit some or all of the data either upon request or based on an alarm. As an example, the data or processed data may be transmitted 2408 back to the originator (e.g., patient or user), it may be transmitted 2409 to a health care provider or doctor, or it may be transmitted 2410 to other designated recipients.

[0130] The cloud 2407 may provide a number of value-add services. For example, the cloud application may store and process the physiological data for future reference or during a visit with the healthcare provider. If a patient has some sort of medical mishap or emergency, the physician can obtain the history of the physiological parameters over a specified period of time. In another embodiment, if the physiological parameters fall out of acceptable range, alarms may be delivered to the user 2408, the healthcare provider 2409, or other designated recipients 2410. These are just some of the features that may be offered, but many others may be possible and are intended to be

covered by this disclosure. As an example, the device 2405 may also have a GPS sensor, so the cloud 2407 may be able to provide time, data and position along with the physiological parameters. Thus, if there is a medical emergency, the cloud 2407 could provide the location of the patient to the healthcare provider 2409 or other designated recipients 2410. Moreover, the digitized data in the cloud 2407 may help to move toward what is often called “personalized medicine.” Based on the physiological parameter data history, medication or medical therapies may be prescribed that are customized to the particular patient.

[0131] Beyond the above benefits, the cloud application 2407 and application on the device 2405 may also have financial value for companies developing measurement devices 2401 such as a non-invasive blood constituent monitor. In the case of glucose monitors, the companies make the majority of their revenue on the measurement strips. However, with a non-invasive monitor, there is no need for strips, so there is less of an opportunity for recurring costs (e.g., the razor/razor blade model does not work for non-invasive devices). On the other hand, people may be willing to pay a periodic fee for the value-add services provided on the cloud 2407. Diabetic patients, for example, would probably be willing to pay a periodic fee for monitoring their glucose levels, storing the history of the glucose levels, and having alarm warnings when the glucose level falls out of range. Similarly, patients taking ketone bodies supplement for treatment of disorders characterized by impaired glucose metabolism (e.g., Alzheimer’s, Parkinson’s, Huntington’s or ALS) may need to monitor their ketone bodies level. These patients would also probably be willing to pay a periodic fee for the value-add services provided on the cloud 2407. Thus, by leveraging the advances in wireless connectivity and the widespread use of handheld devices such as smart phones that can wirelessly connect to the cloud, businesses can build a recurring cost business model even using non-invasive measurement devices.

[0132] Described herein are just some examples of the beneficial use of near-infrared or SWIR lasers for non-invasive monitoring of glucose, ketones, HbA1c and other blood constituents. However, many other medical procedures can use the near-infrared or SWIR light consistent with this disclosure and are intended to be covered by the disclosure.

[0133] Although the present disclosure has been described in several embodiments, a myriad of changes, variations, alterations, transformations, and modifications may be suggested to one skilled in the art, and it is intended that the present disclosure encompass such changes, variations, alterations, transformations, and modifications as falling within the spirit and scope of the appended claims.

[0134] While exemplary embodiments are described above, it is not intended that these embodiments describe all possible forms of the disclosure. Rather, the words used in the specification are words of description rather than limitation, and it is understood that various changes may be made without departing from the spirit and scope of the disclosure. Additionally, the features of various implementing embodiments may be combined to form further embodiments of the disclosure. While various embodiments may have been described as providing advantages or being preferred over other embodiments with respect to one or more desired characteristics, as one skilled in the art is aware, one or more characteristics may be compromised to achieve desired system attributes, which depend on the specific application and implementation. These attributes include, but are not limited to: cost, strength, durability, life cycle cost, marketability, appearance, packaging, size, serviceability, weight, manufacturability, ease of assembly, etc. The embodiments described herein that are described as less desirable than other embodiments or prior art implementations with respect to one or more characteristics are not outside the scope of the disclosure and may be desirable for particular applications.

WHAT IS CLAIMED IS:

1. A diagnostic system comprising:

a light source configured to generate an output optical beam, comprising:

one or more semiconductor sources configured to generate an input beam;

one or more optical amplifiers configured to receive at least a portion of the input beam and to deliver an intermediate beam to an output end of the one or more optical amplifiers;

one or more optical fibers configured to receive at least a portion of the intermediate beam and to deliver at least the portion of the intermediate beam to a distal end of the one or more optical fibers to form a first optical beam;

a nonlinear element configured to receive at least a portion of the first optical beam and to broaden a spectrum associated with the at least a portion of the first optical beam to at least 10 nanometers through a nonlinear effect in the nonlinear element to form the output optical beam with an output beam broadened spectrum; and

wherein at least a portion of the output beam broadened spectrum comprises a short-wave infrared wavelength between approximately 1400 nanometers and approximately 2500 nanometers, and wherein at least a portion of the one of more fibers is a fused silica fiber with a core diameter less than approximately 400 microns;

an interface device configured to receive a received portion of the output optical beam and to deliver a delivered portion of the output optical beam to a sample, wherein the delivered portion of the output optical beam is configured to generate a spectroscopy output beam from the sample; and

a receiver configured to receive at least a portion of the spectroscopy output beam having a bandwidth of at least 10 nanometers and to process the portion of the spectroscopy output beam to generate an output signal representing at least in part a property of hydro-carbon bonds.

2. The system of Claim 1, wherein the interface device further comprises a replaceable insert.

3. The system of Claim 1, wherein the sample comprises at least in part enamel, dentine and blood, and wherein the output signal represents at least in part a property of the blood.

4. The system of Claim 1, wherein the input beam comprises a repetition rate between approximately one kilohertz and approximately 100MHz.

5. The system of Claim 1, wherein the receiver further comprises a wireless transmitter configured to communicate a wireless signal associated with the output signal to a network.

6. A measurement system comprising:

a light source generating an output optical beam, comprising:

a plurality of semiconductor sources generating an input optical beam;

a multiplexer configured to receive at least a portion of the input optical beam and to form an intermediate optical beam; and

one or more fibers configured to receive at least a portion of the intermediate optical beam and to form the output optical beam, wherein the output optical beam comprises one or more optical wavelengths;

an interface device configured to receive a received portion of the output optical beam and to deliver a delivered portion of the output optical beam to a sample comprising at least in part enamel, dentine and pulp, wherein the delivered portion of the output optical beam is configured to generate a spectroscopy output beam from the sample; and

a receiver configured to receive at least a portion of the spectroscopy output beam and to process the portion of the spectroscopy output beam to generate an output signal representing at least in part a property of blood contained within the pulp.

7. The system of Claim 6, wherein the light source comprises a super-continuum laser.
8. The system of Claim 6, wherein the light source comprises a super-luminescent diode.
9. The system of Claim 6, wherein the light source comprises a light emitting diode.
10. The system of Claim 6, wherein at least a portion of the one of more optical wavelengths comprises a short-wave infrared wavelength between approximately 1400 nanometers and approximately 2500 nanometers.
11. The system of Claim 6, wherein the property of the blood comprises a glucose level.
12. The system of Claim 11, wherein at least a portion of the one or more optical wavelengths is near 1587 nanometers or near 1750 nanometers.
13. The system of Claim 11, wherein at least a portion of the one or more optical wavelengths is near 2120 nanometers, near 2270 nanometers, or near 2320 nanometers.
14. The system of Claim 6, wherein the delivered portion of the output optical beam is transmitted through the sample.
15. The system of Claim 6, wherein the interface device further comprises a replaceable insert.
16. The system of Claim 6, wherein the receiver is configured to process the portion of the spectroscopy output beam using a pattern matching methodology.

17. A method of measuring comprising:
generating an output optical beam, comprising:
generating an input optical beam from a plurality of semiconductor sources;
multiplexing at least a portion of the input optical beam and forming an intermediate optical beam; and
guiding at least a portion of the intermediate optical beam and forming the output optical beam, wherein the output optical beam comprises one or more optical wavelengths;
receiving a received portion of the output optical beam and delivering a delivered portion of the output optical beam to a sample, wherein the sample comprises at least in part enamel, dentine and pulp;
generating a spectroscopy output beam from the sample;
receiving at least a portion of the spectroscopy output beam; and
processing the portion of the spectroscopy output beam and generating an output signal representing at least in part a property of blood contained within the pulp.
18. The method of claim 17, wherein the one or more optical wavelengths comprises a short-wave infrared wavelength between approximately 1400 nanometers and approximately 2500 nanometers.
19. The method of claim 17, wherein the property of the blood comprises a glucose level.
20. The method of claim 17, further comprising communicating a wireless signal associated with the output signal to a network.

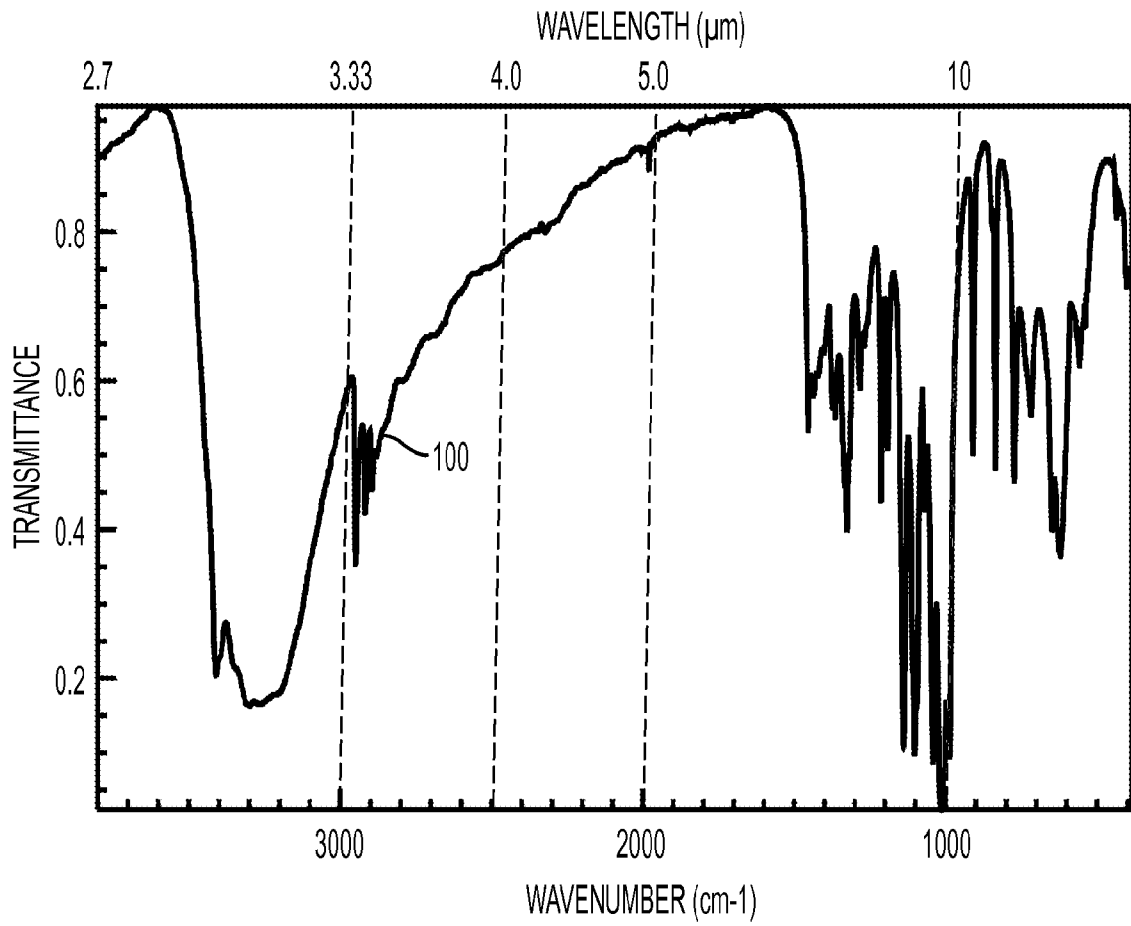

FIG. 1

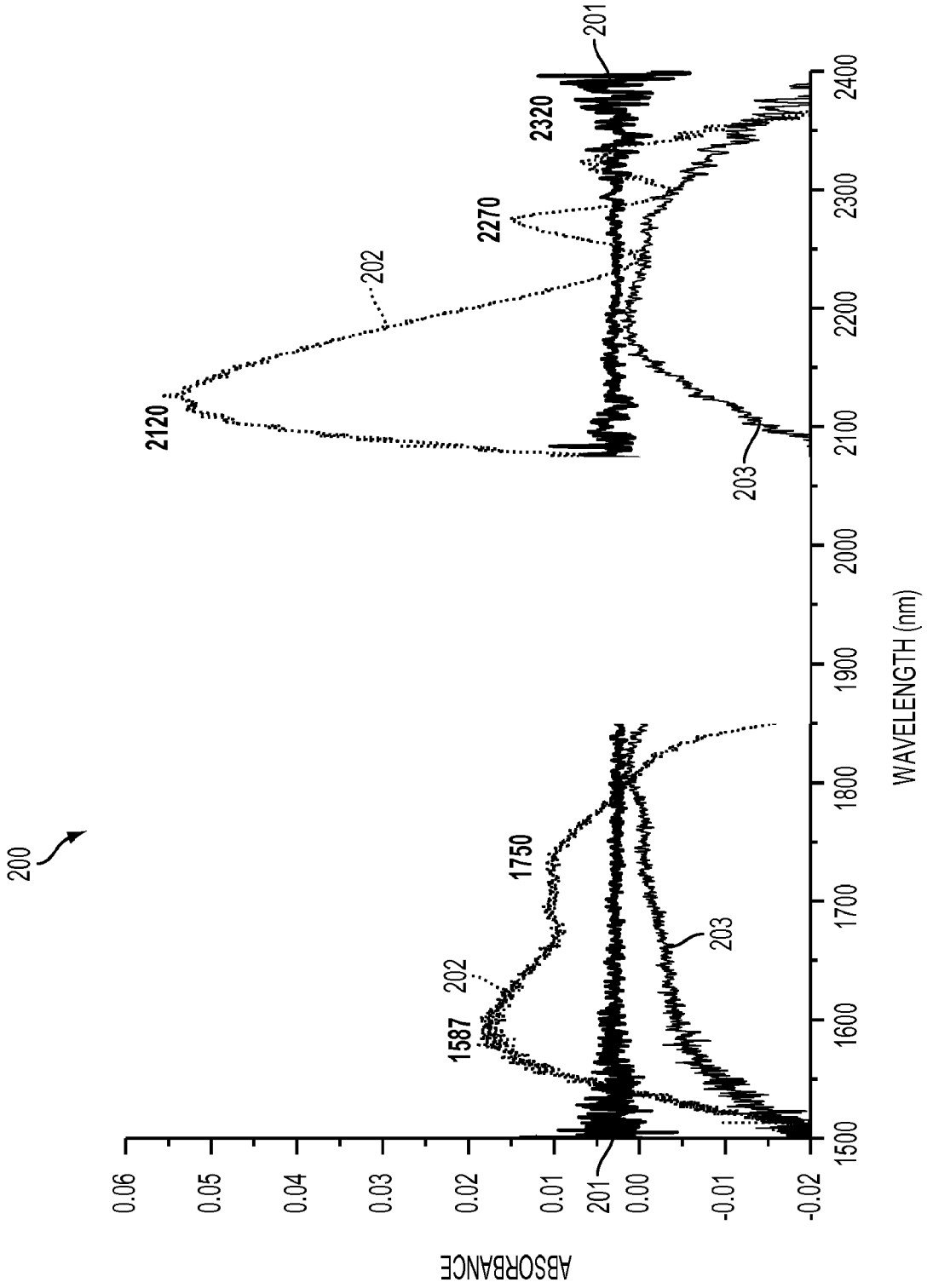

FIG. 2

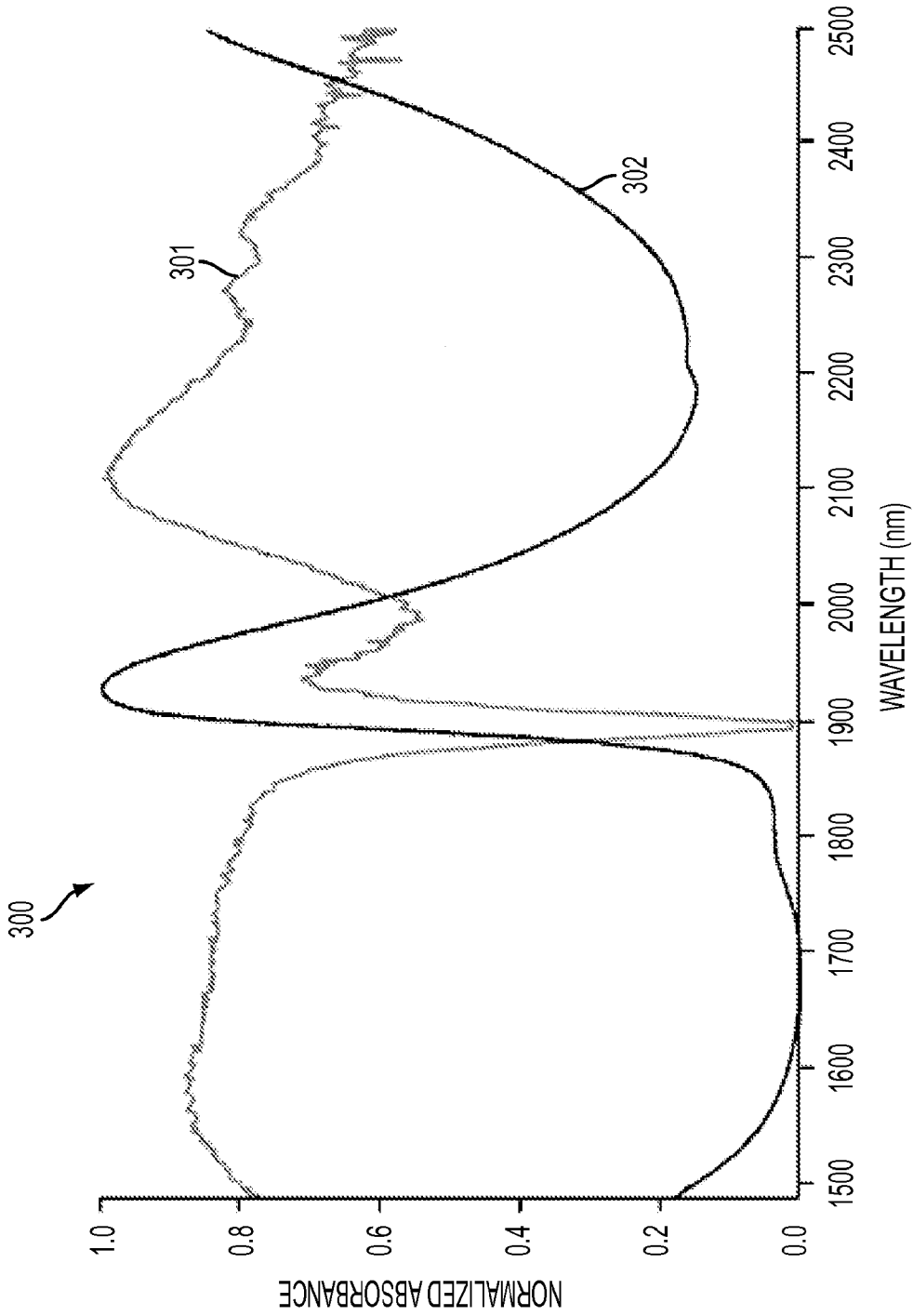

FIG. 3A

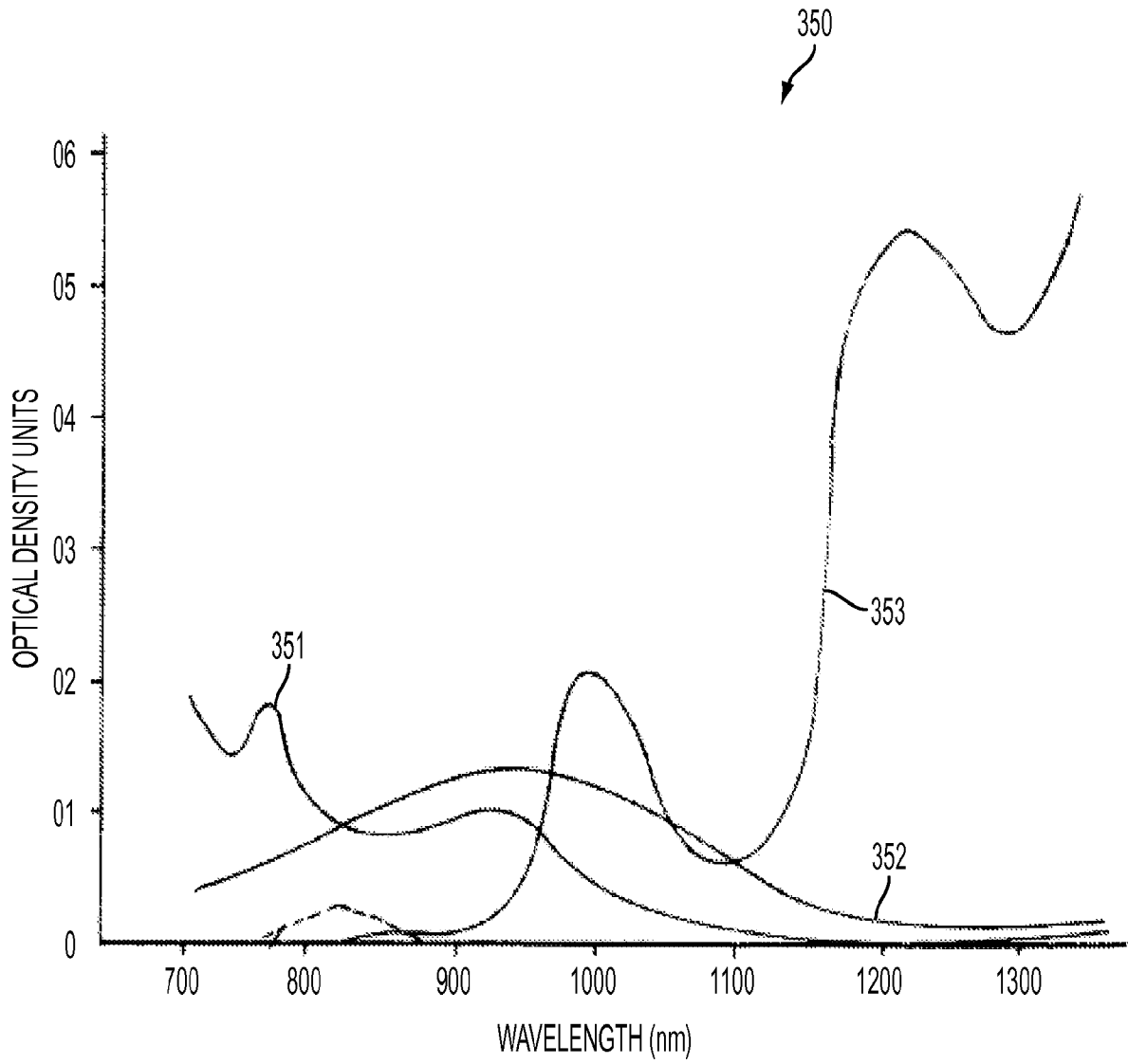

FIG. 3B

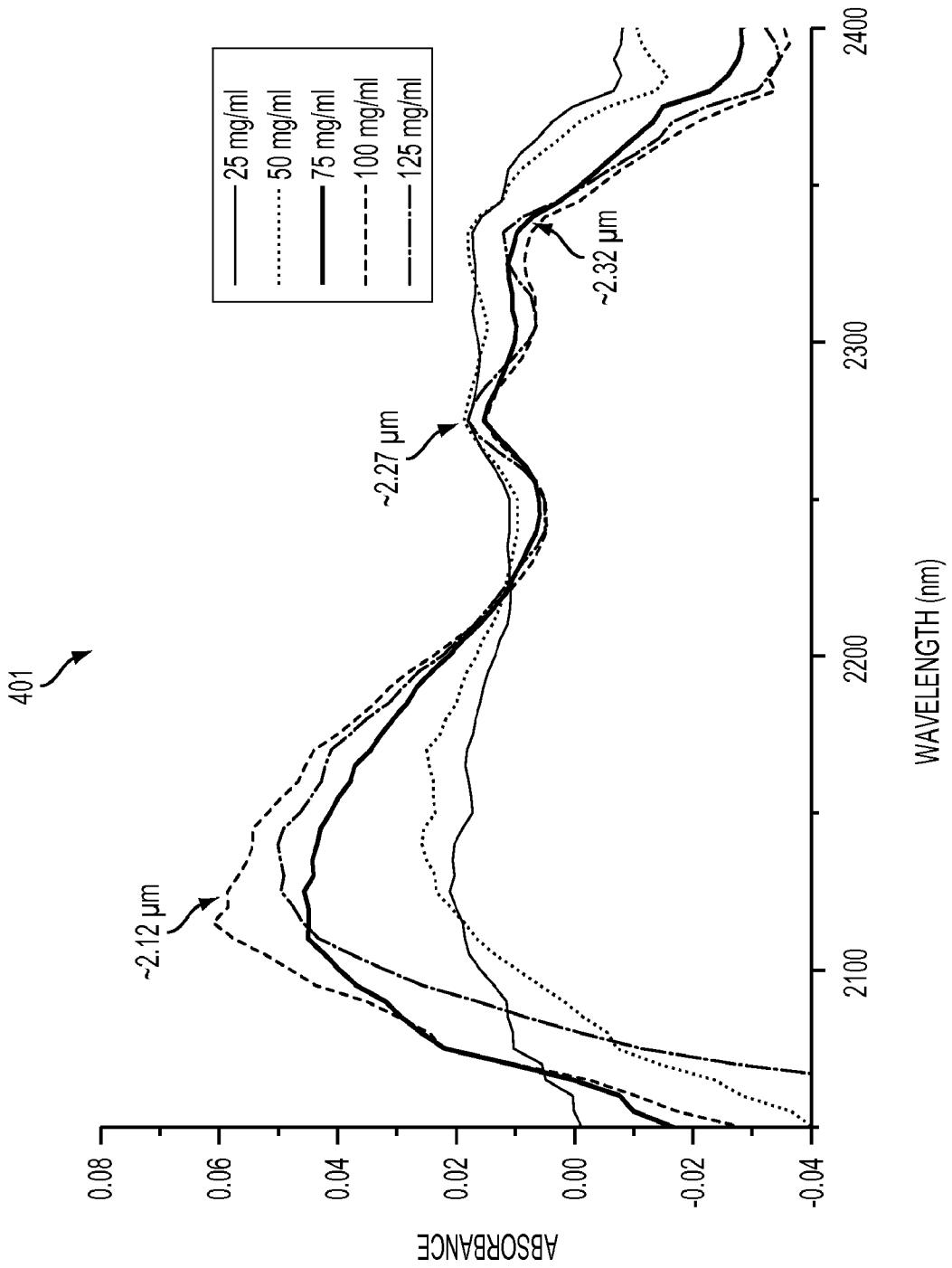

FIG. 4A

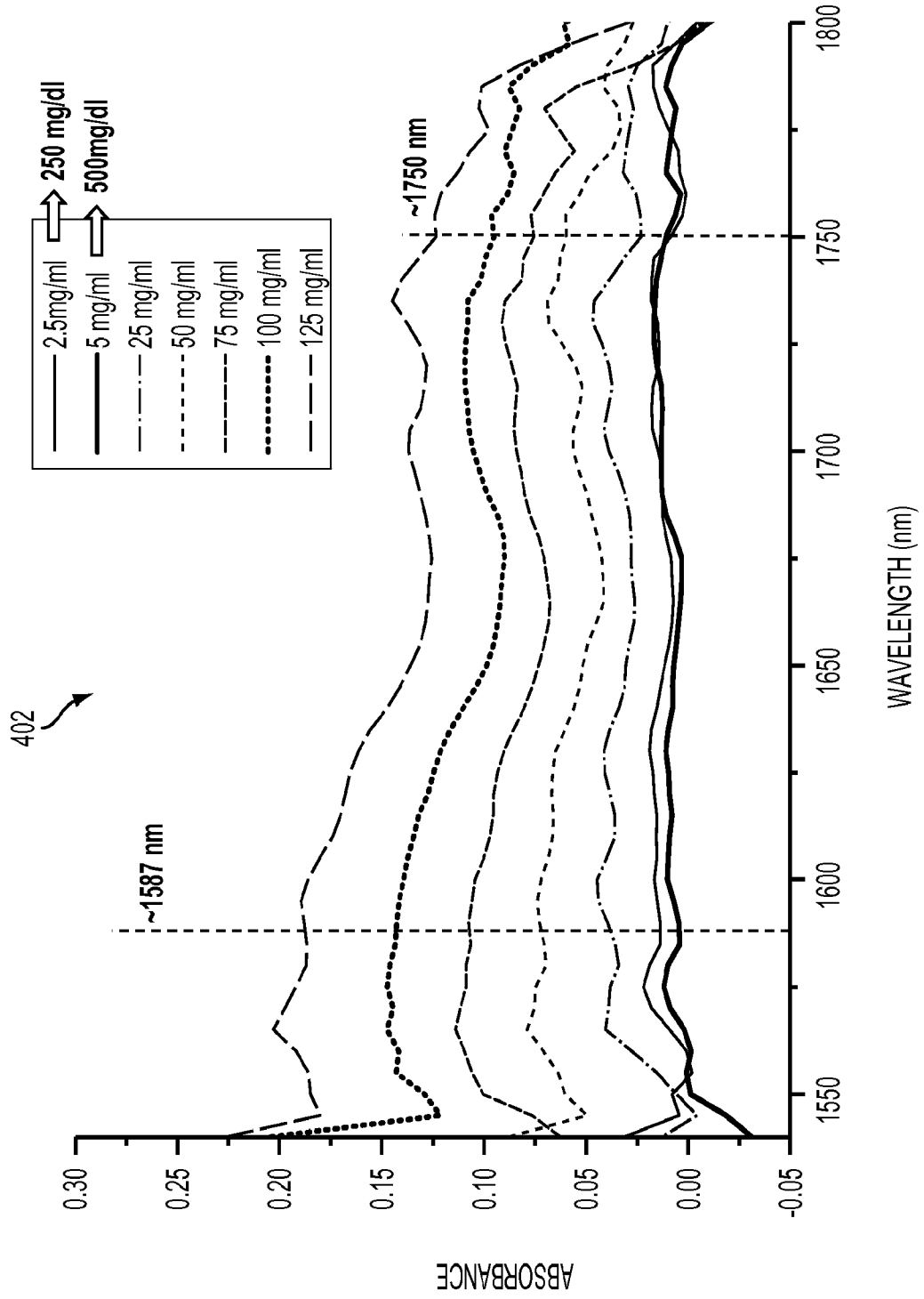

FIG. 4B

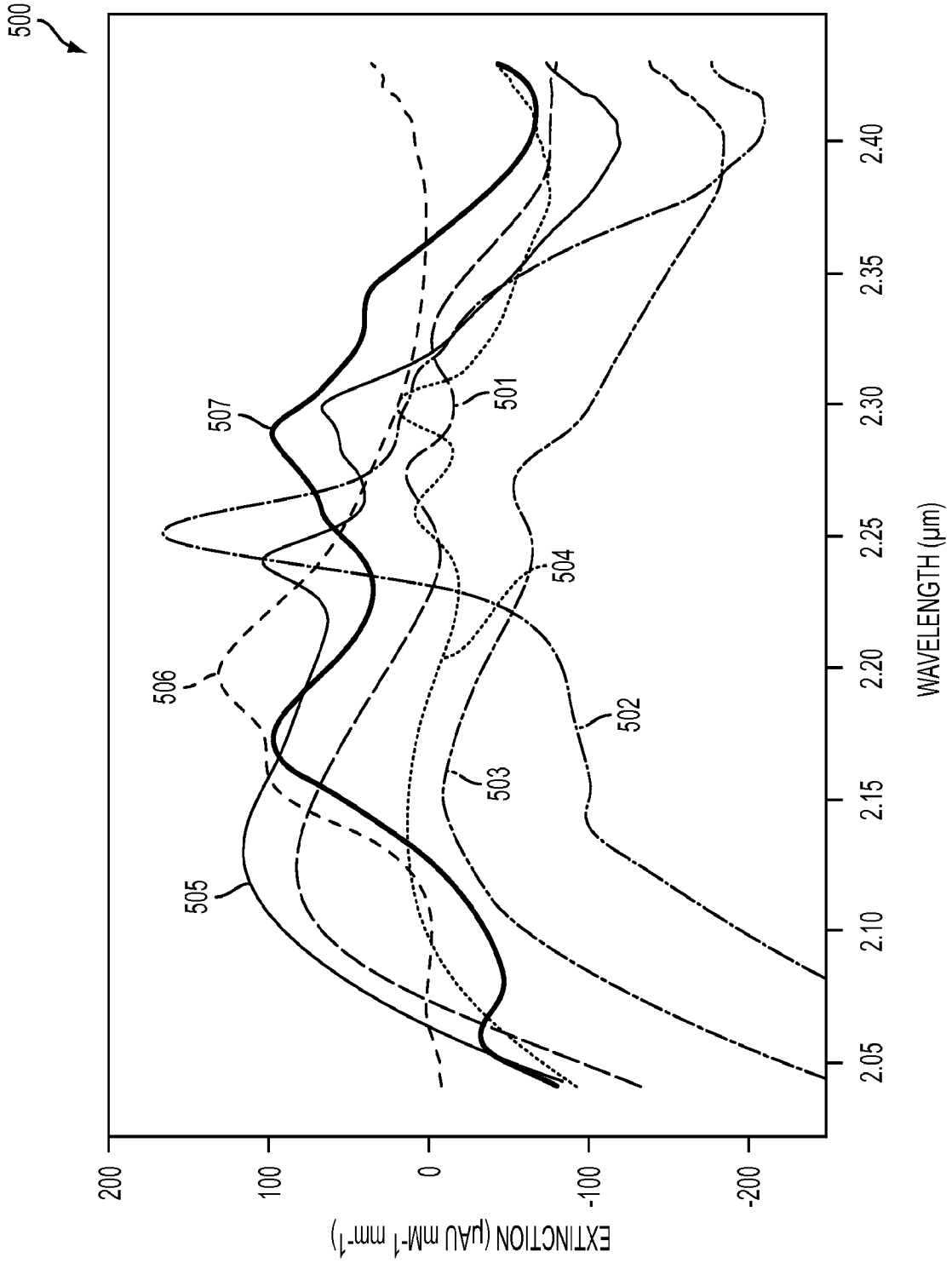

FIG. 5

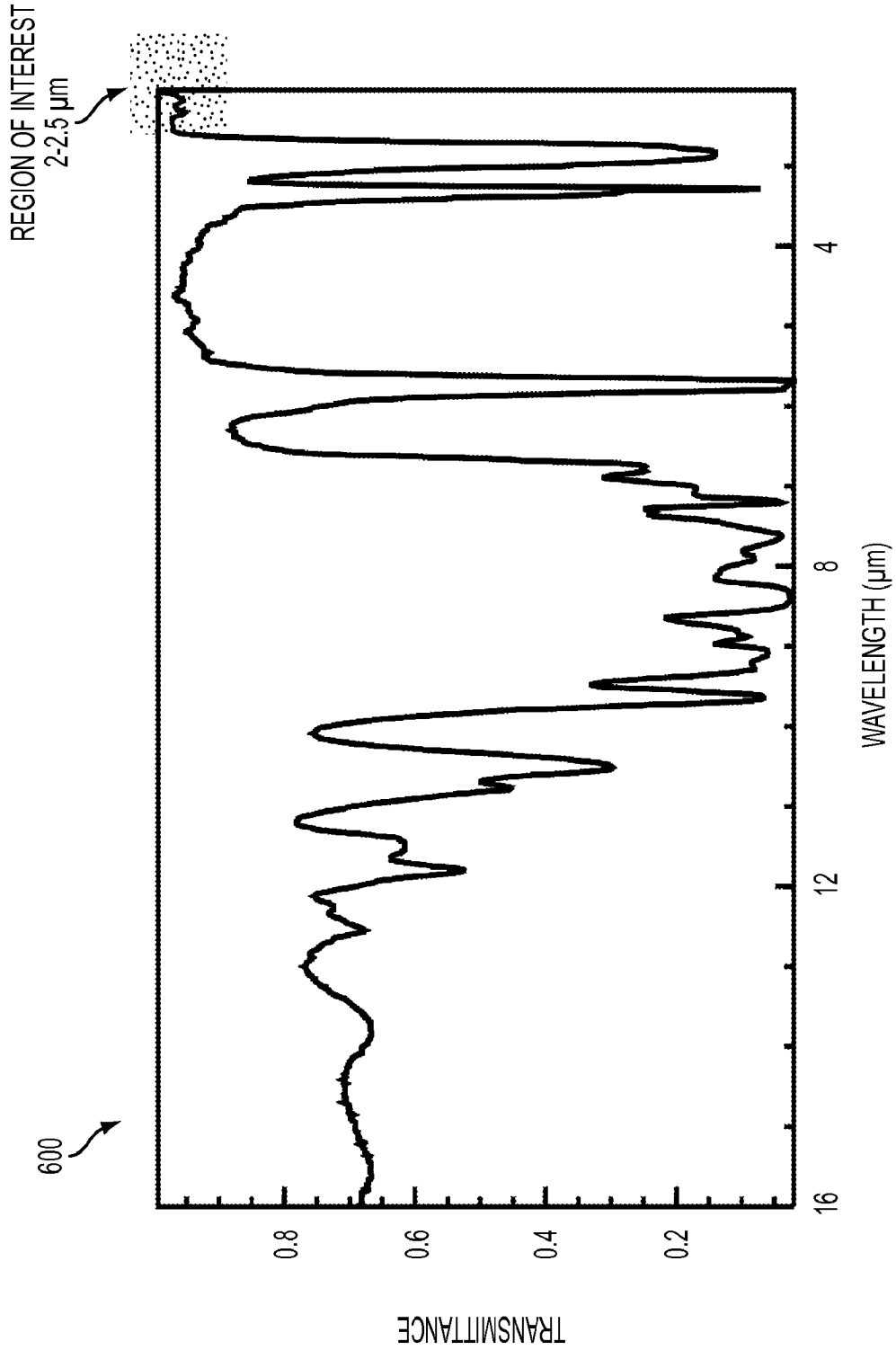

FIG. 6

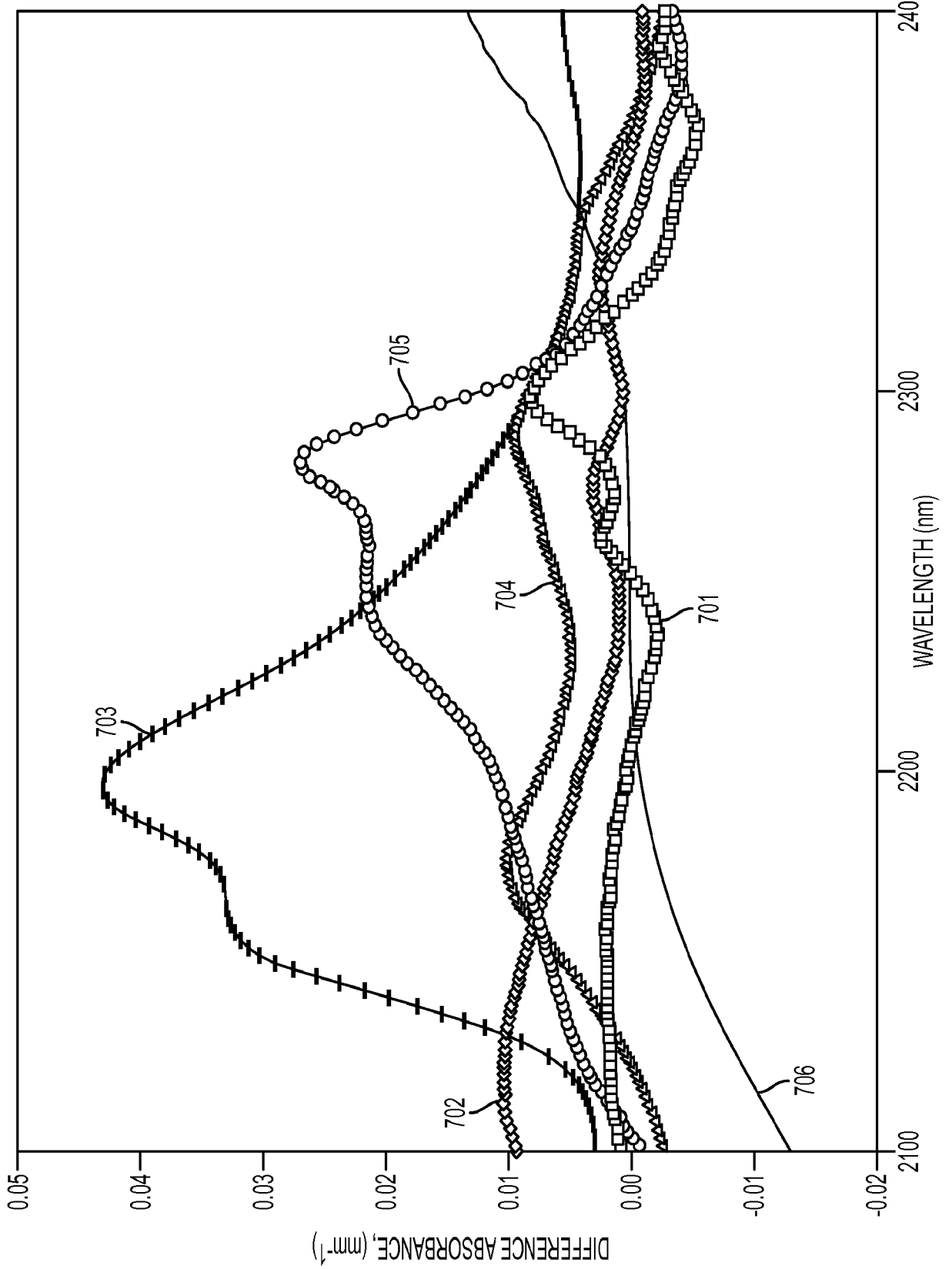

FIG. 7

800 ↙

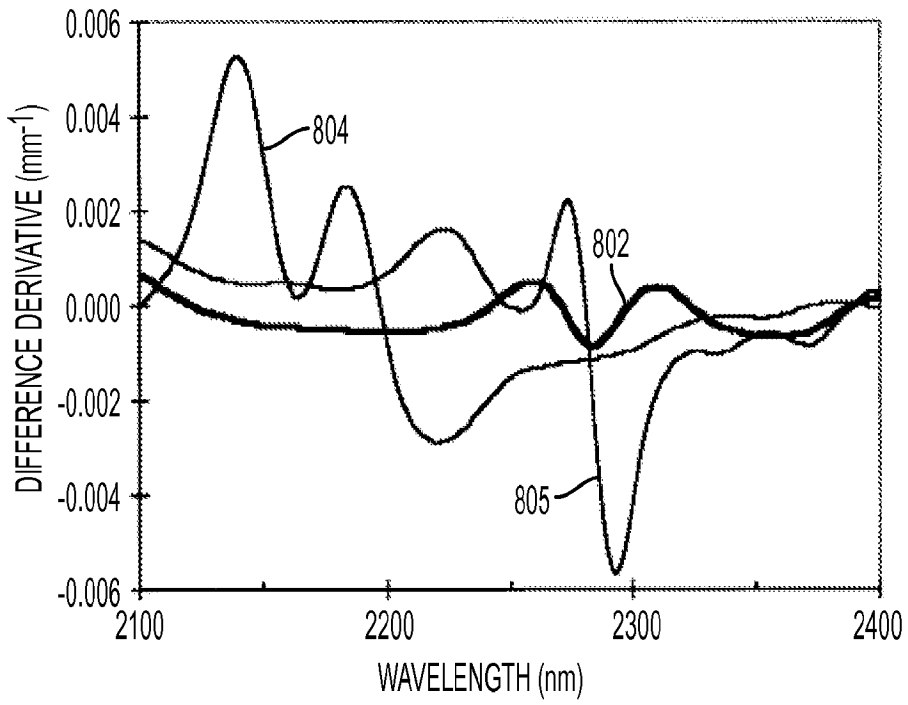
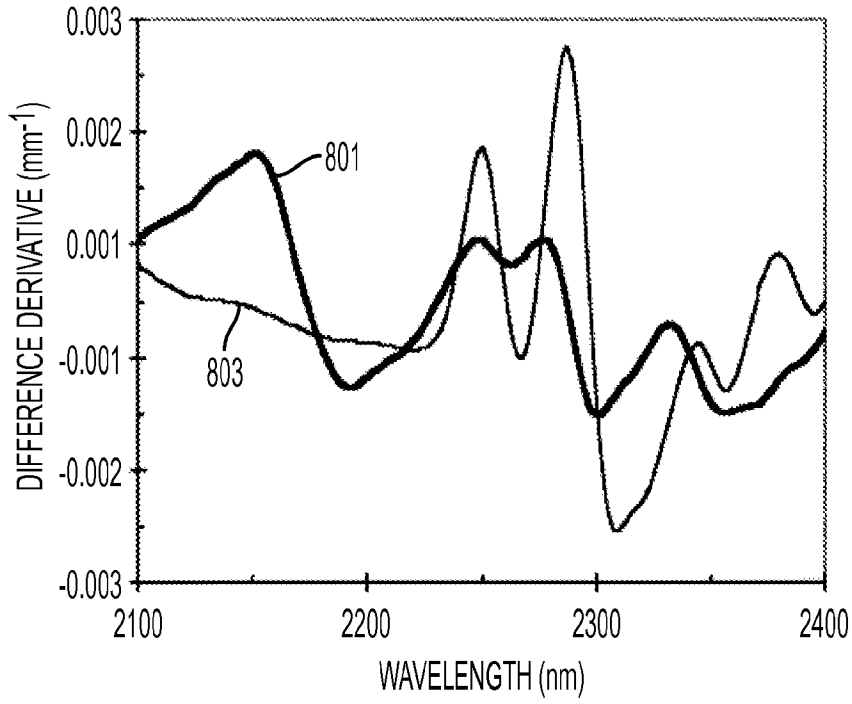

FIG. 8A

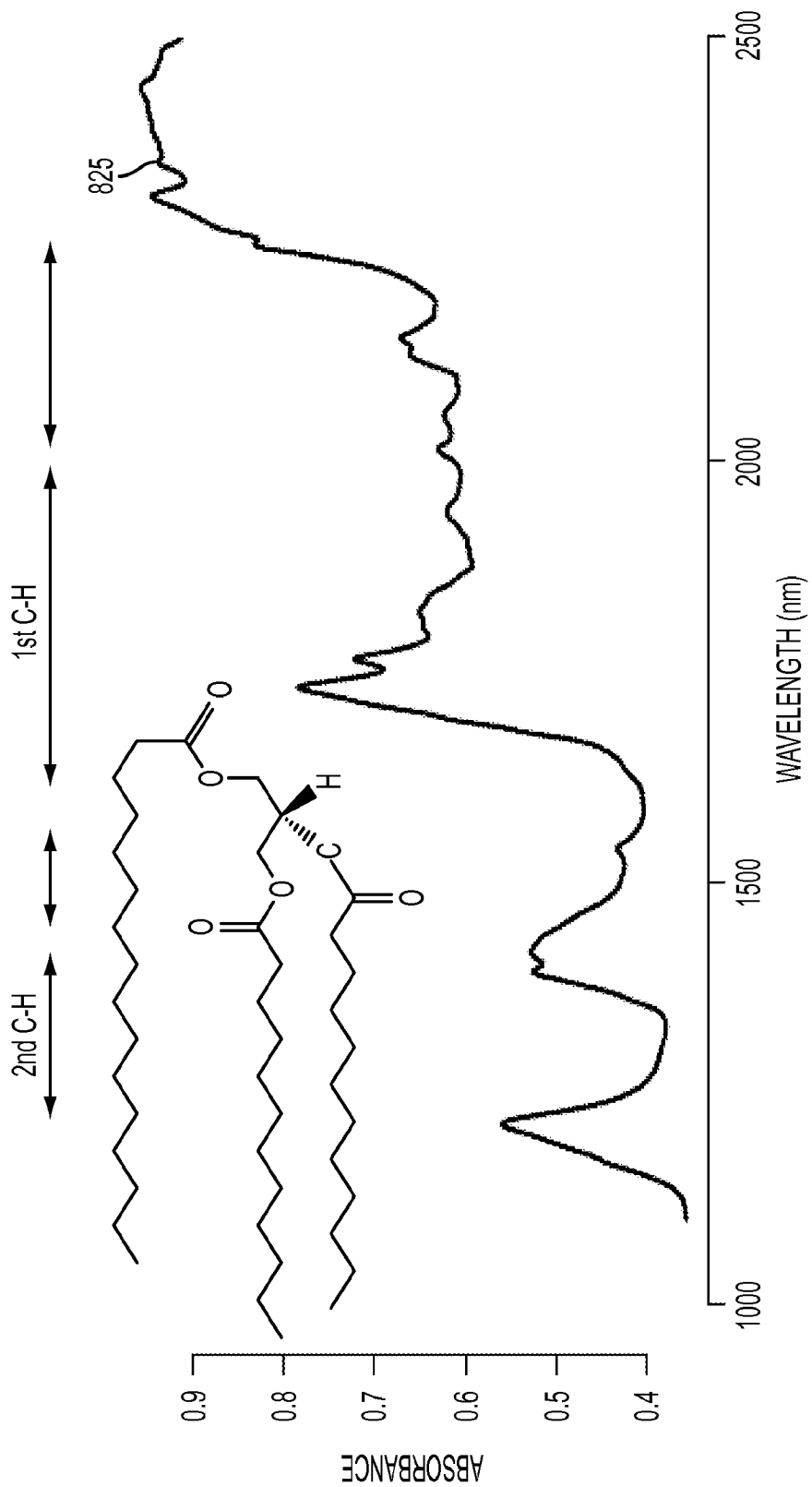

FIG. 8B

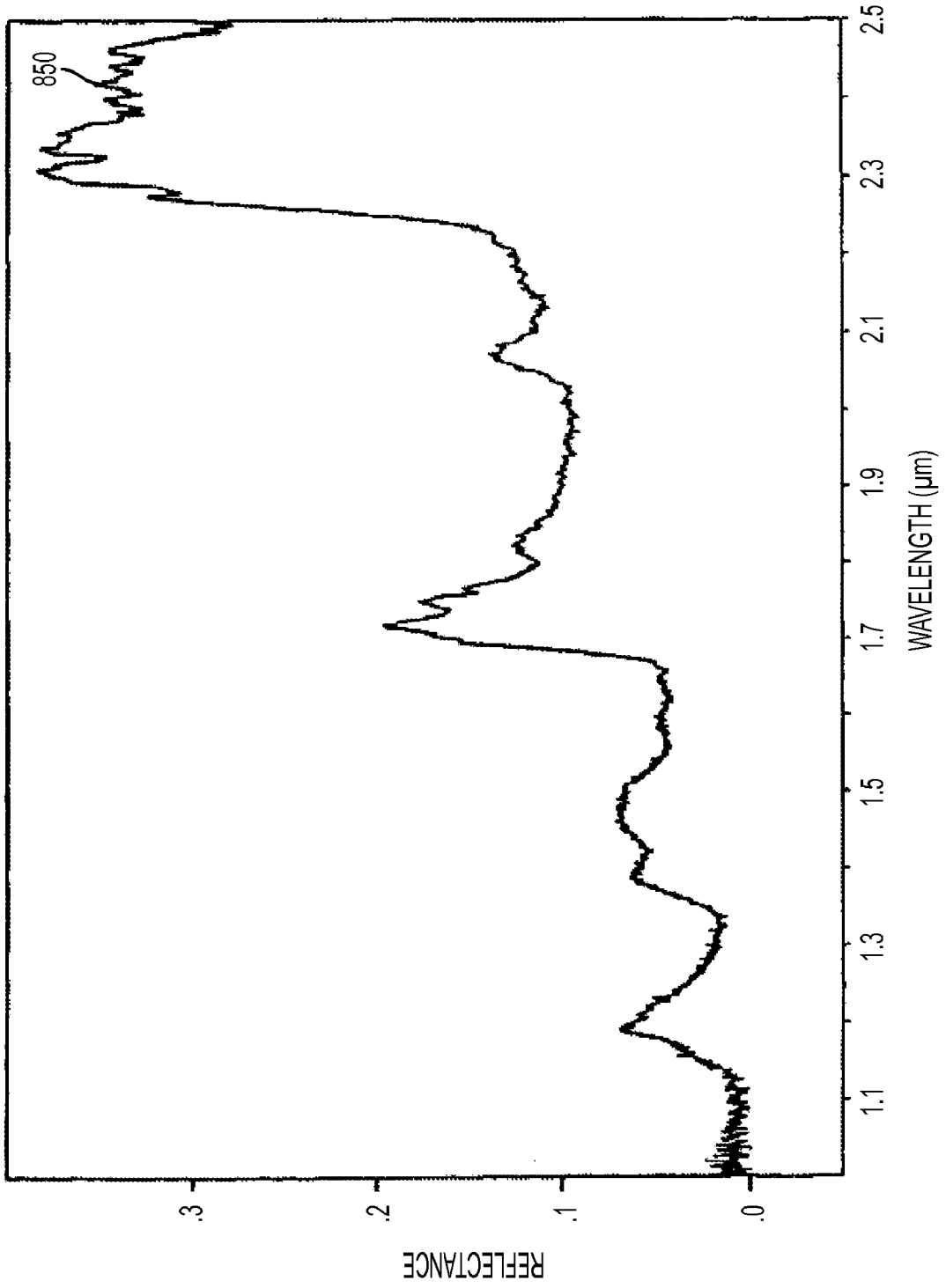

FIG. 8C

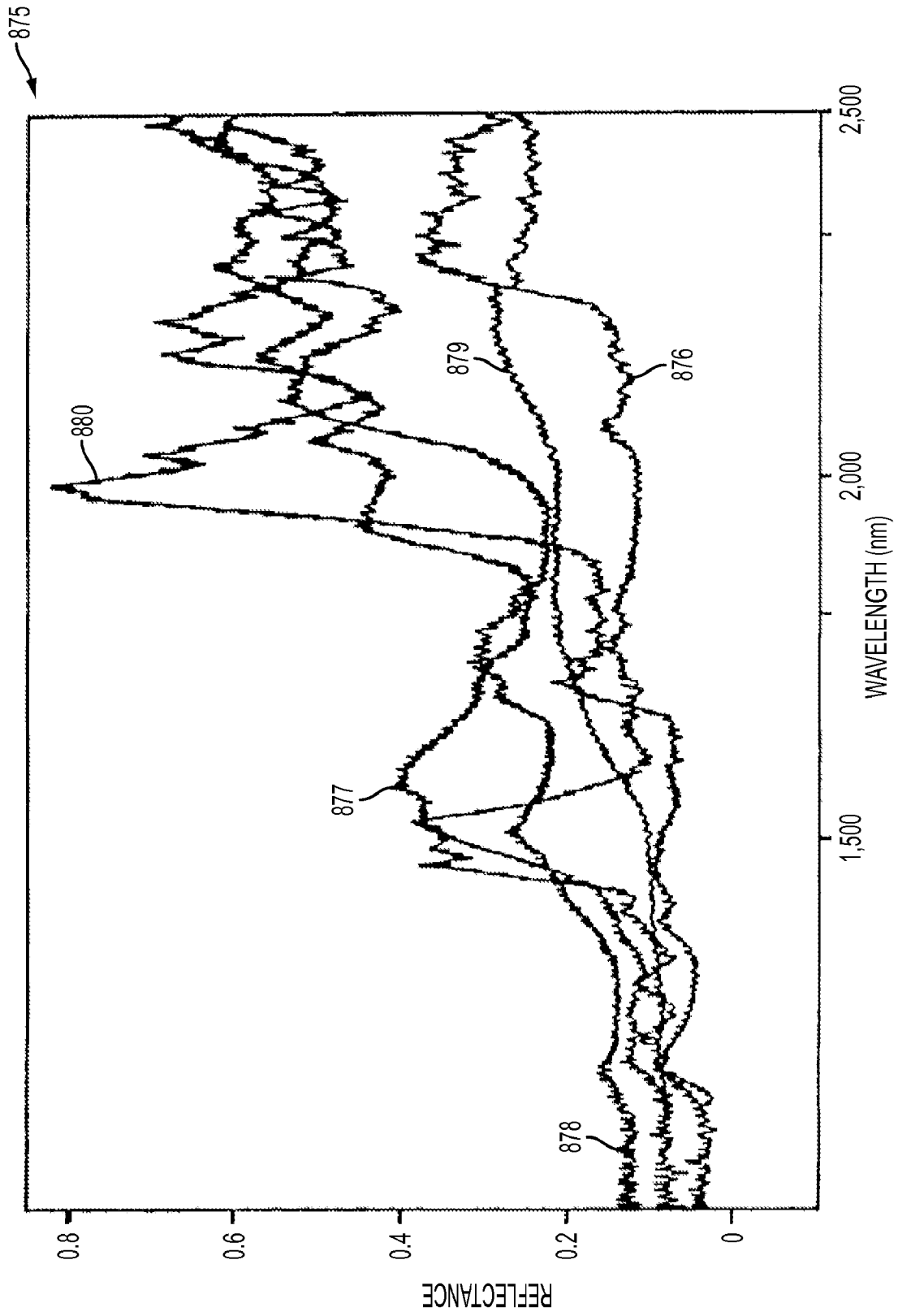

FIG. 8D

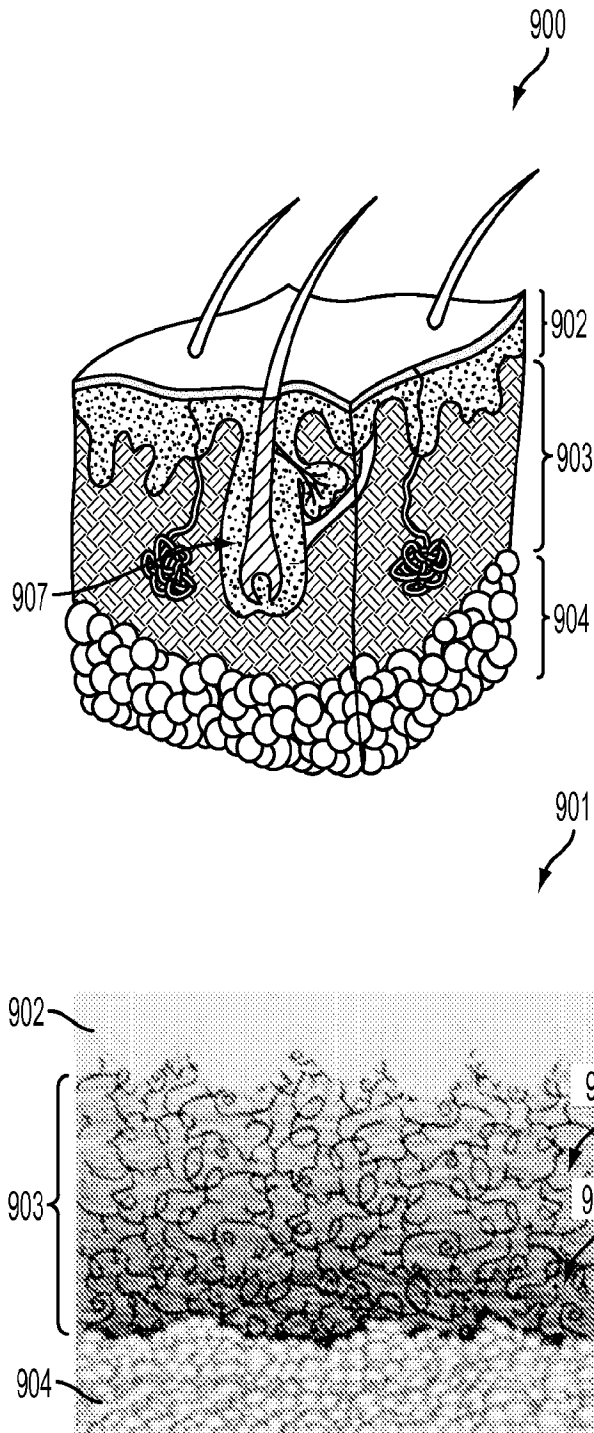

FIG. 9

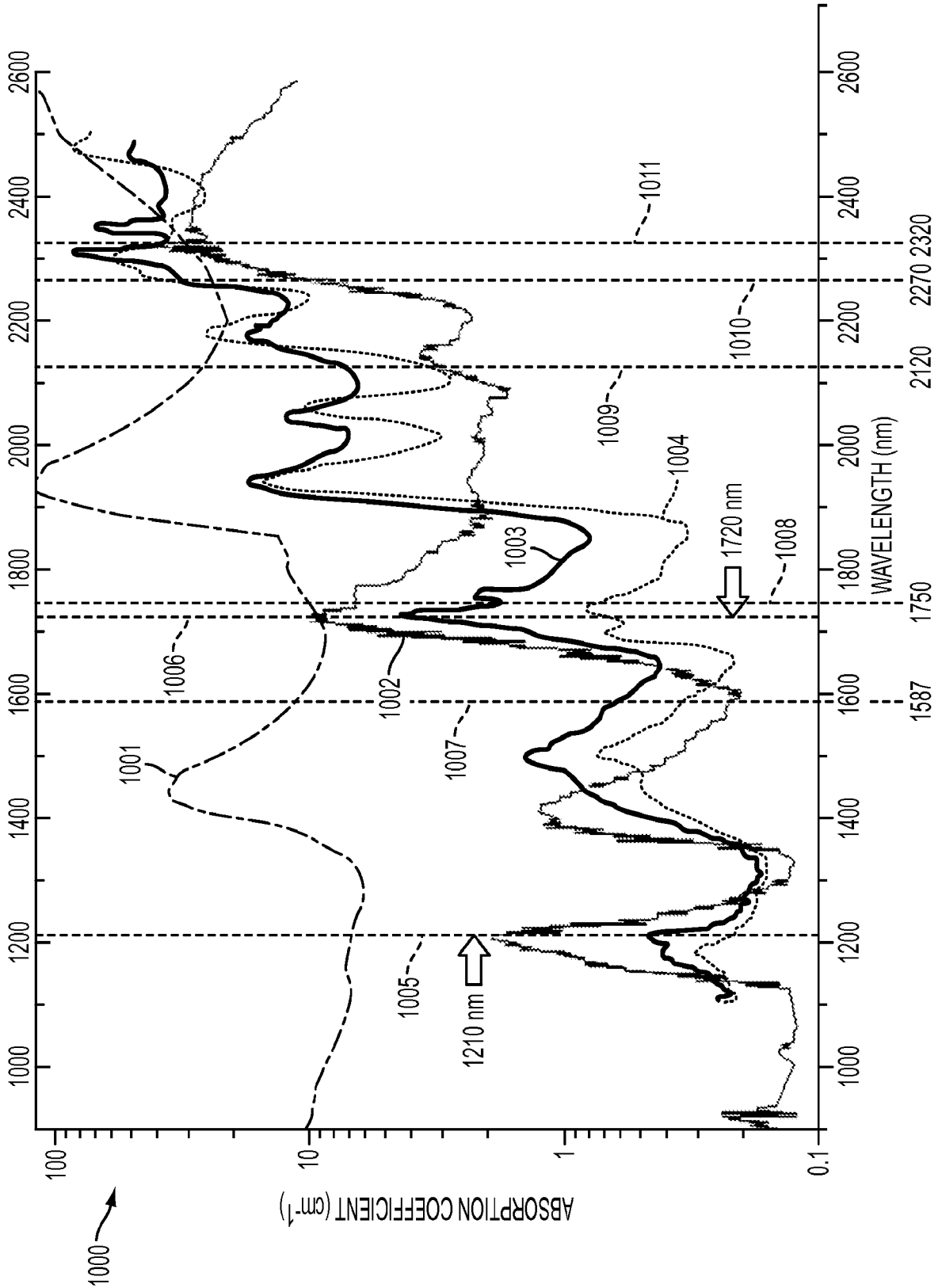

FIG. 10

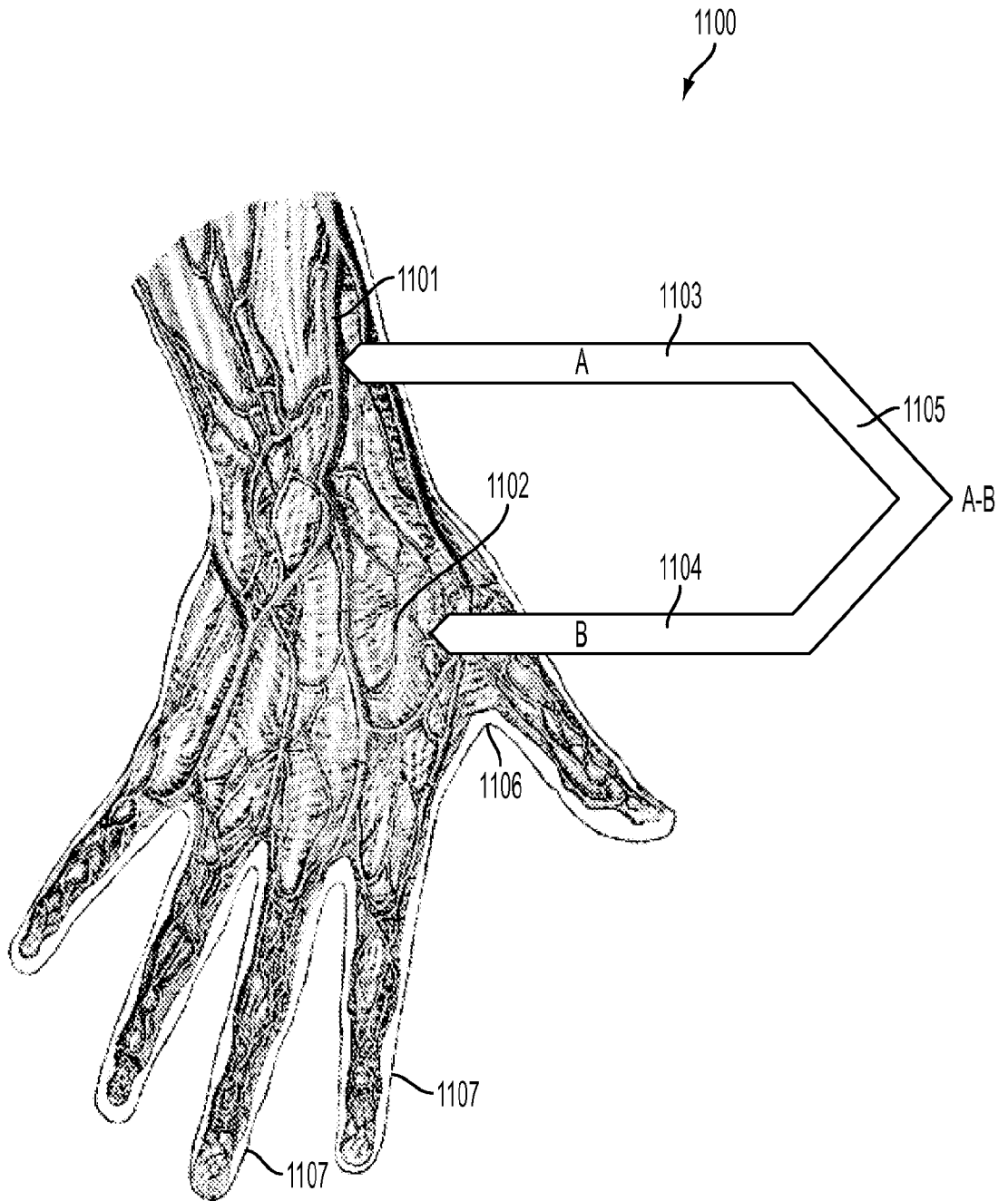

FIG. 11

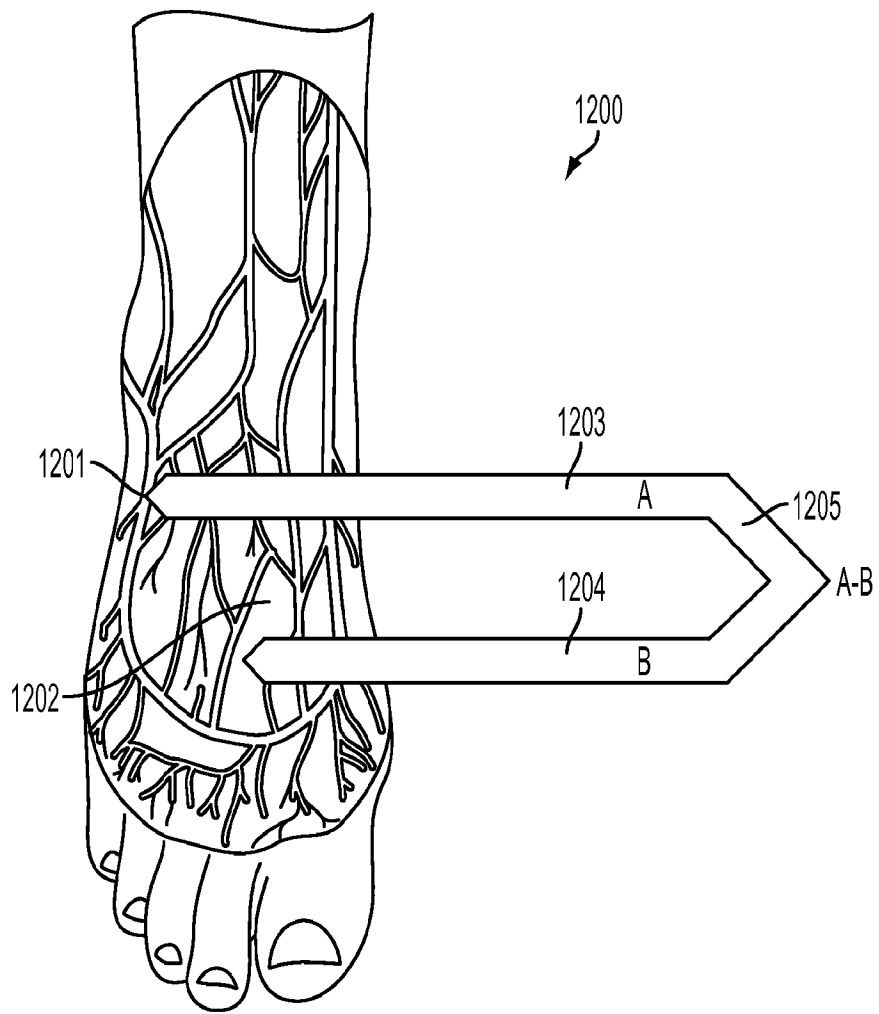

FIG. 12

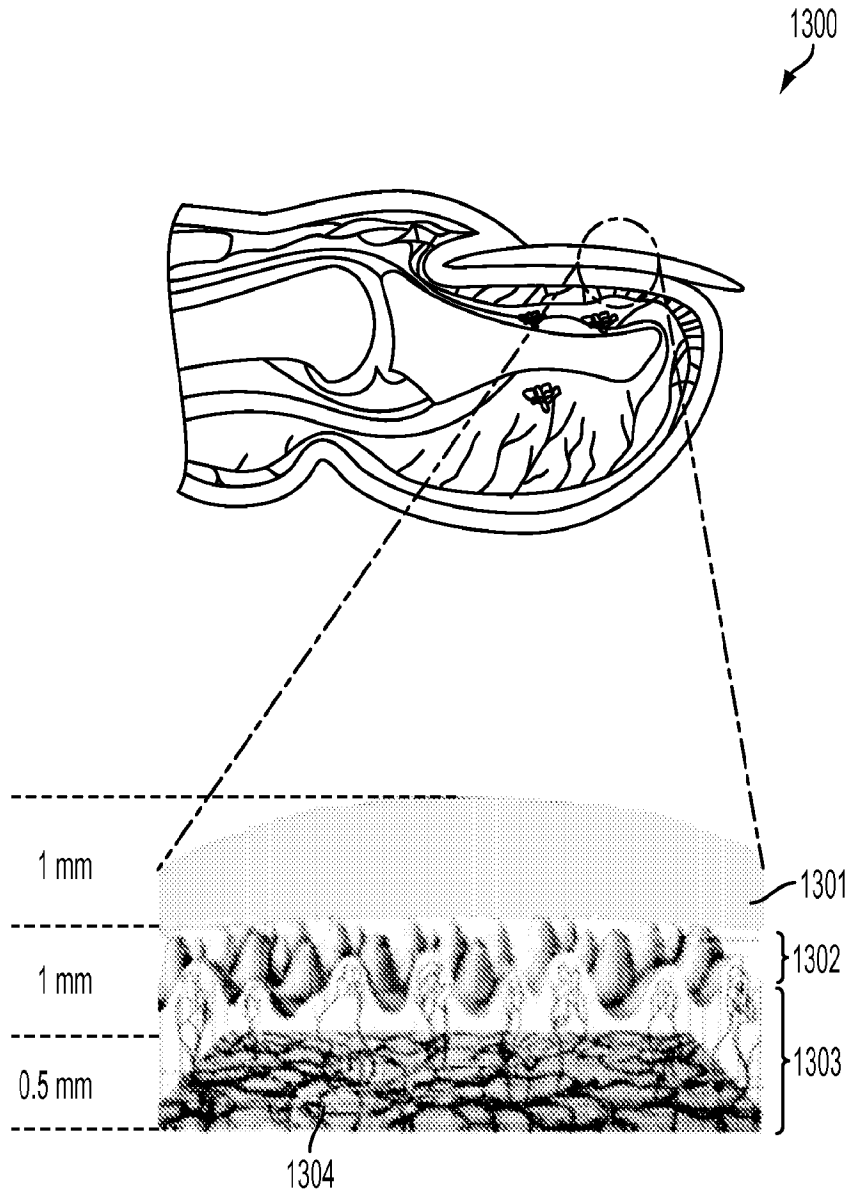

FIG. 13

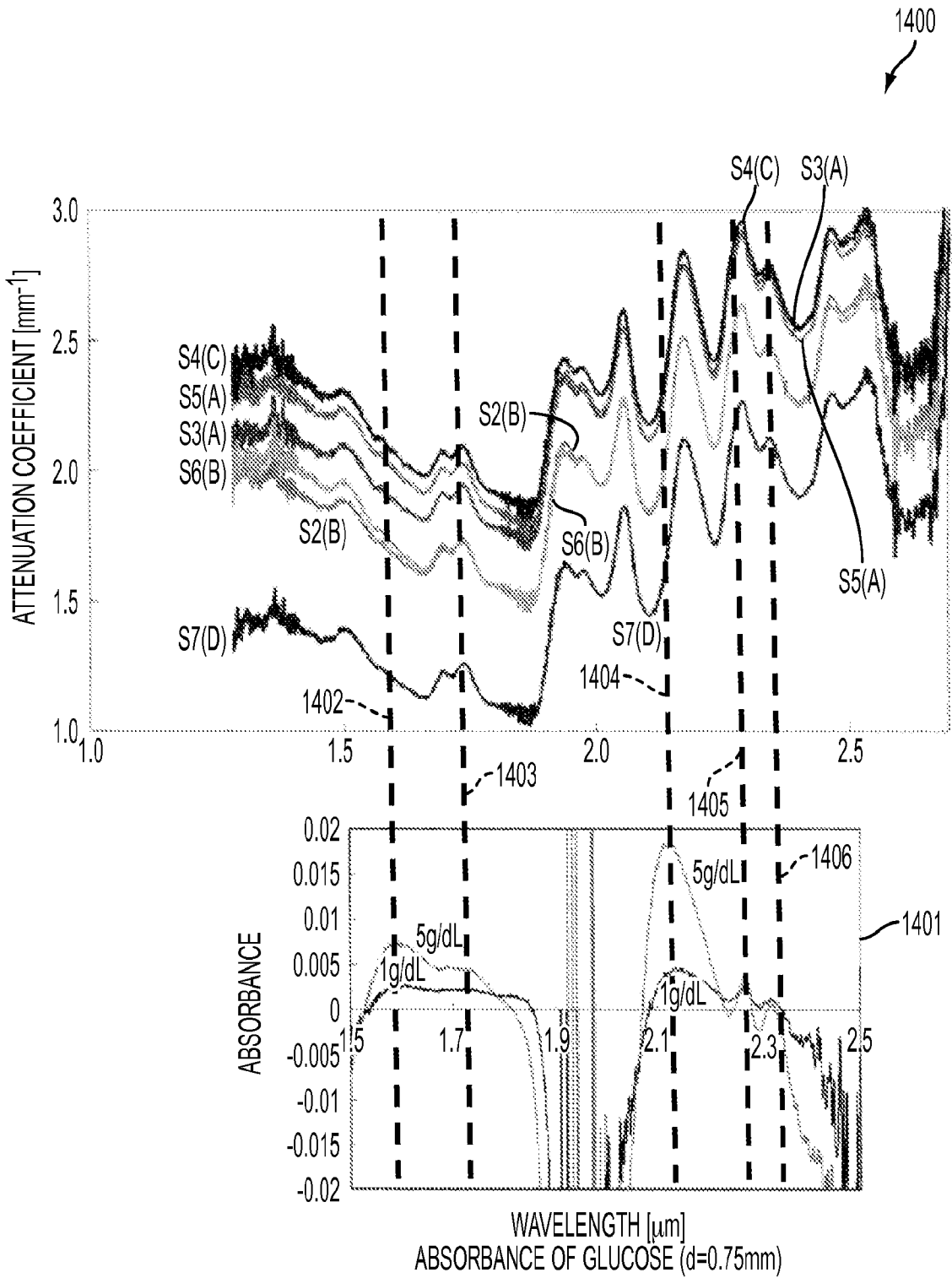

FIG. 14

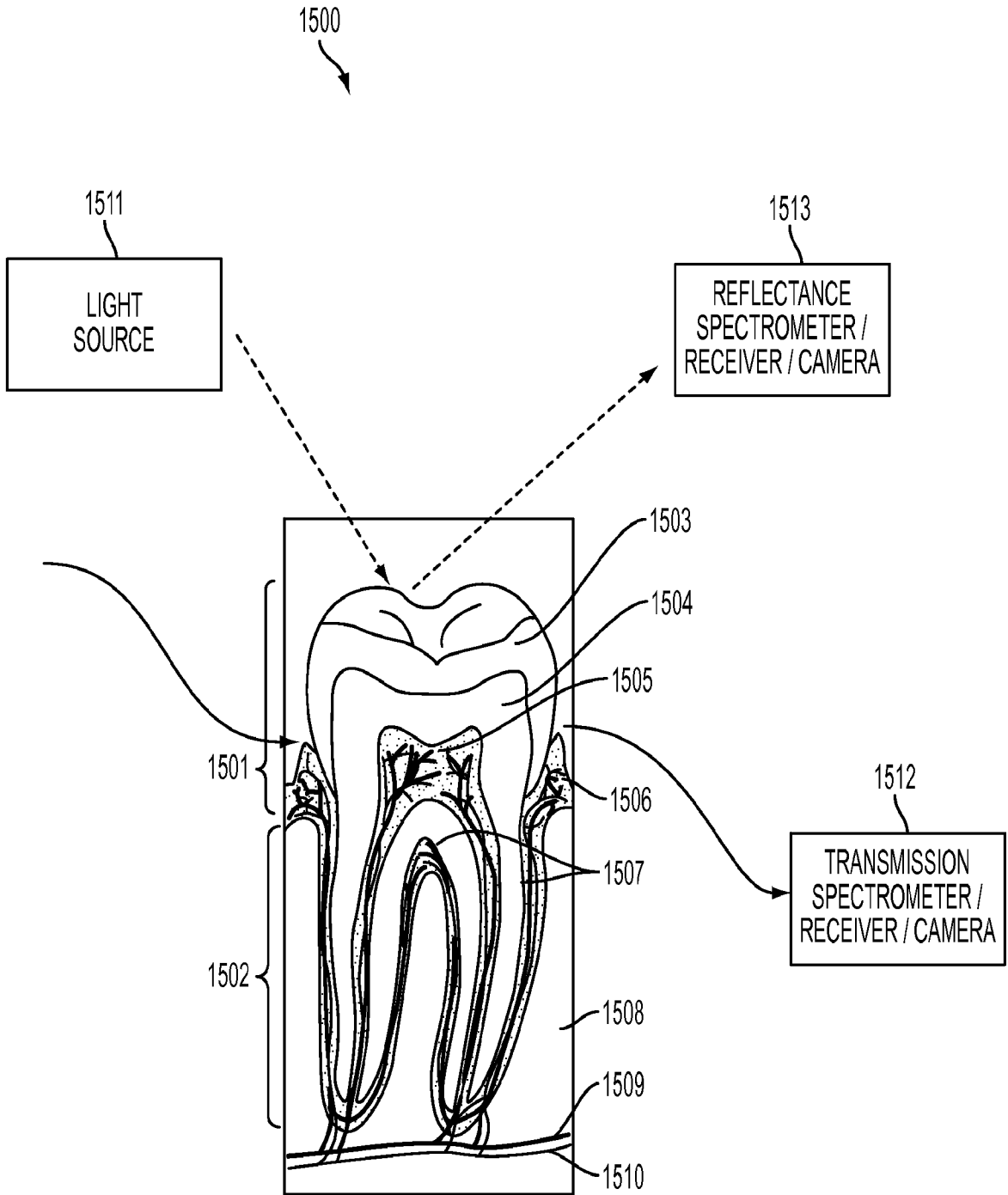

FIG. 15

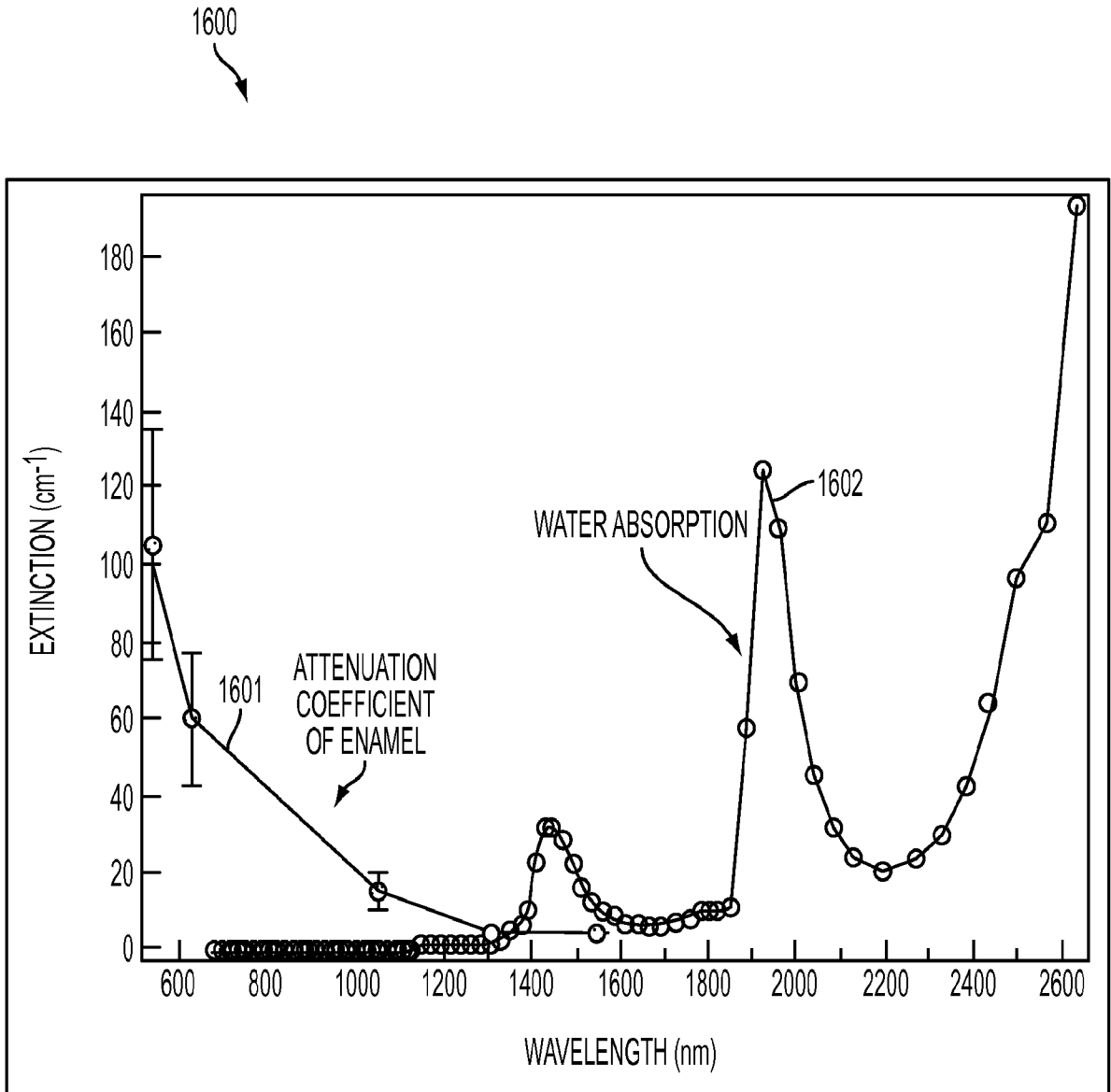

FIG. 16A

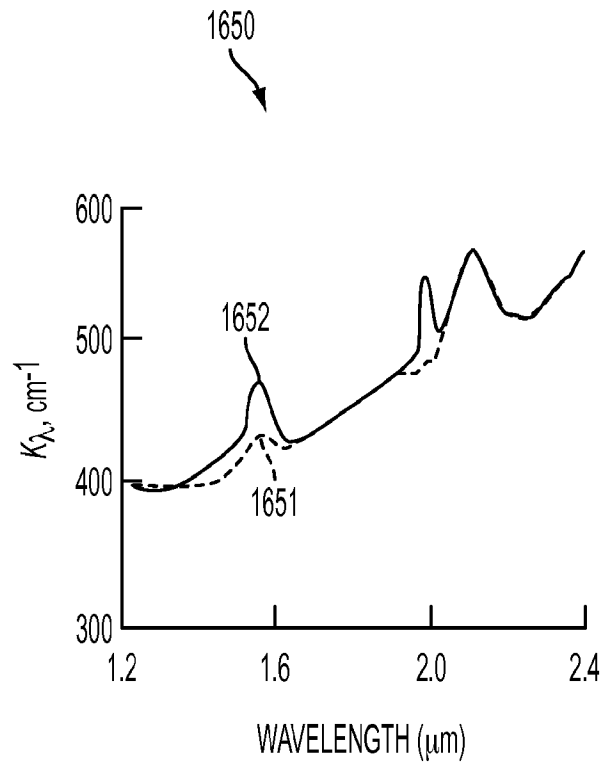

FIG. 16B

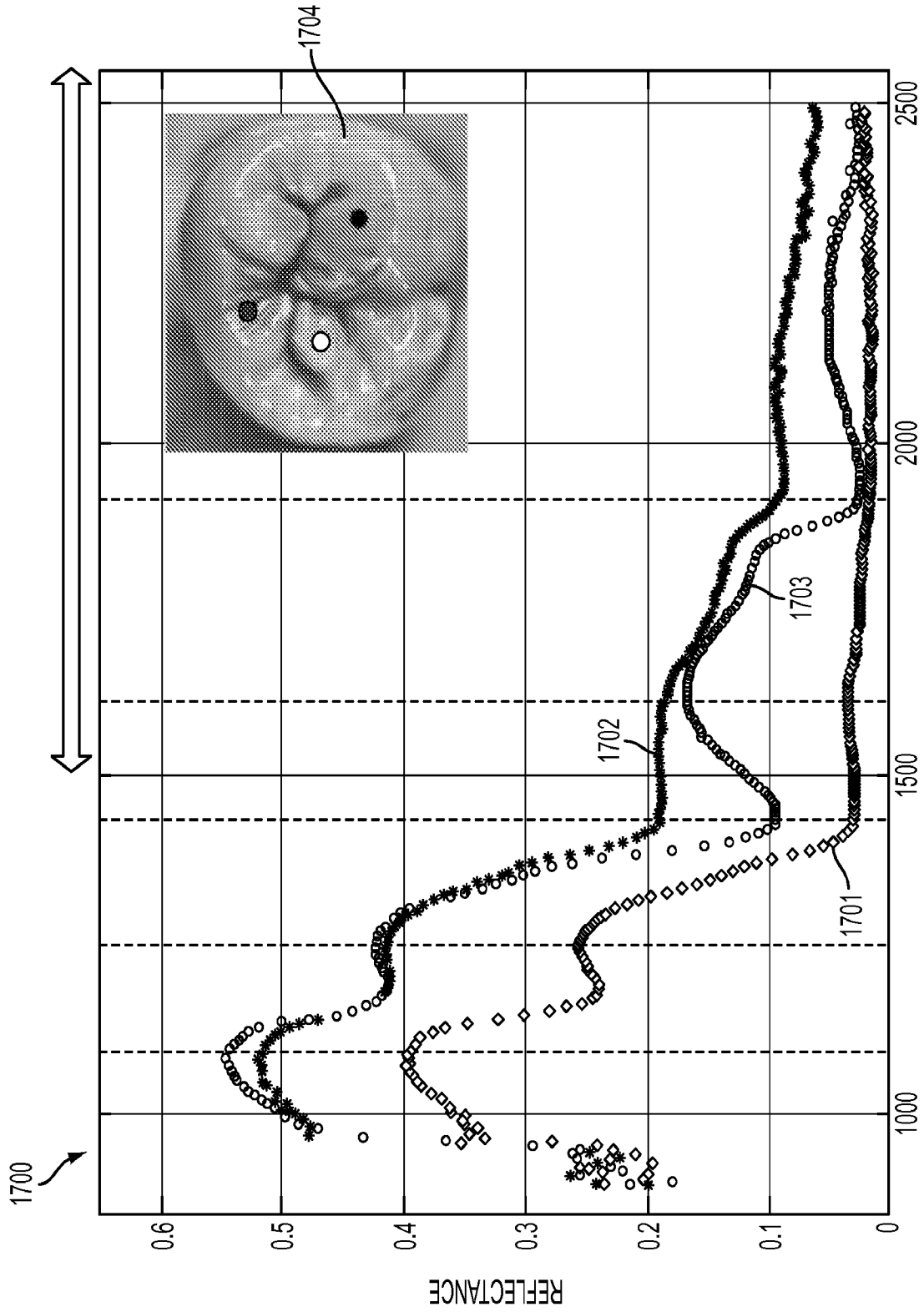

FIG. 17

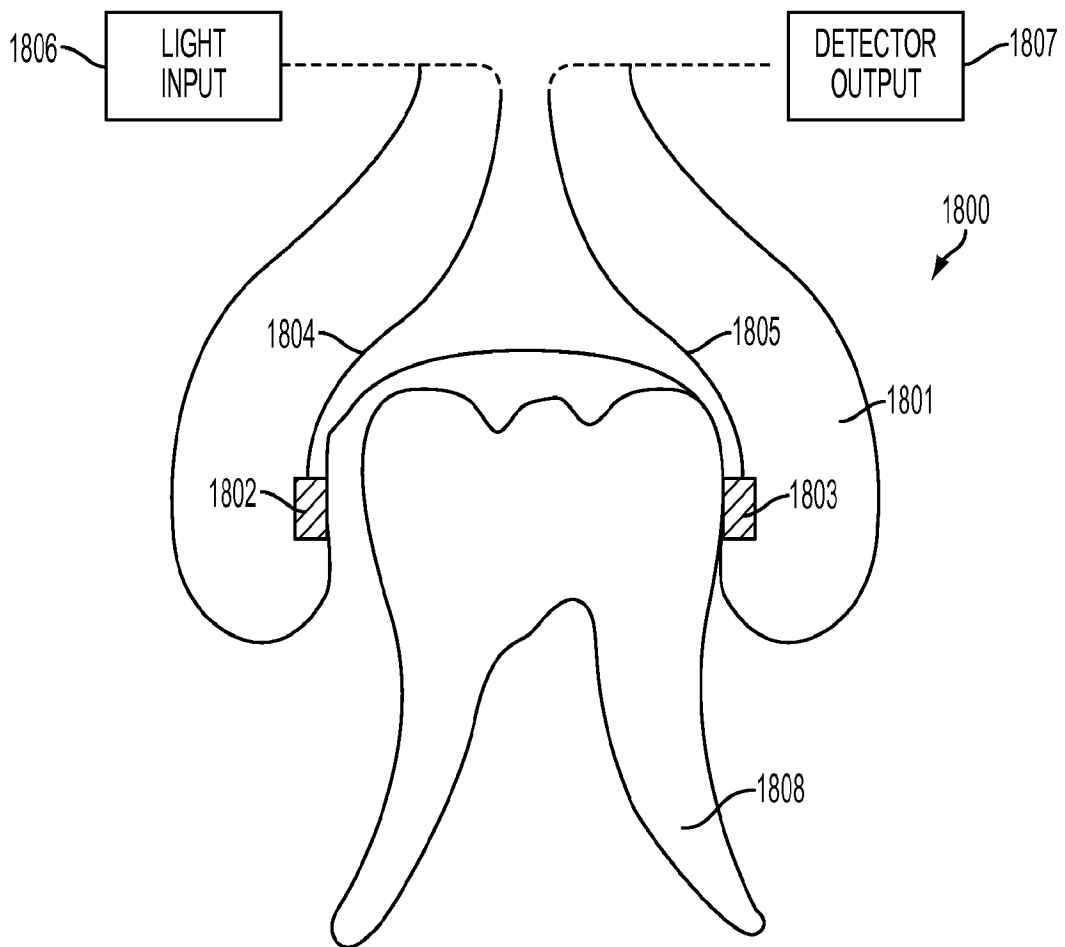

FIG. 18A

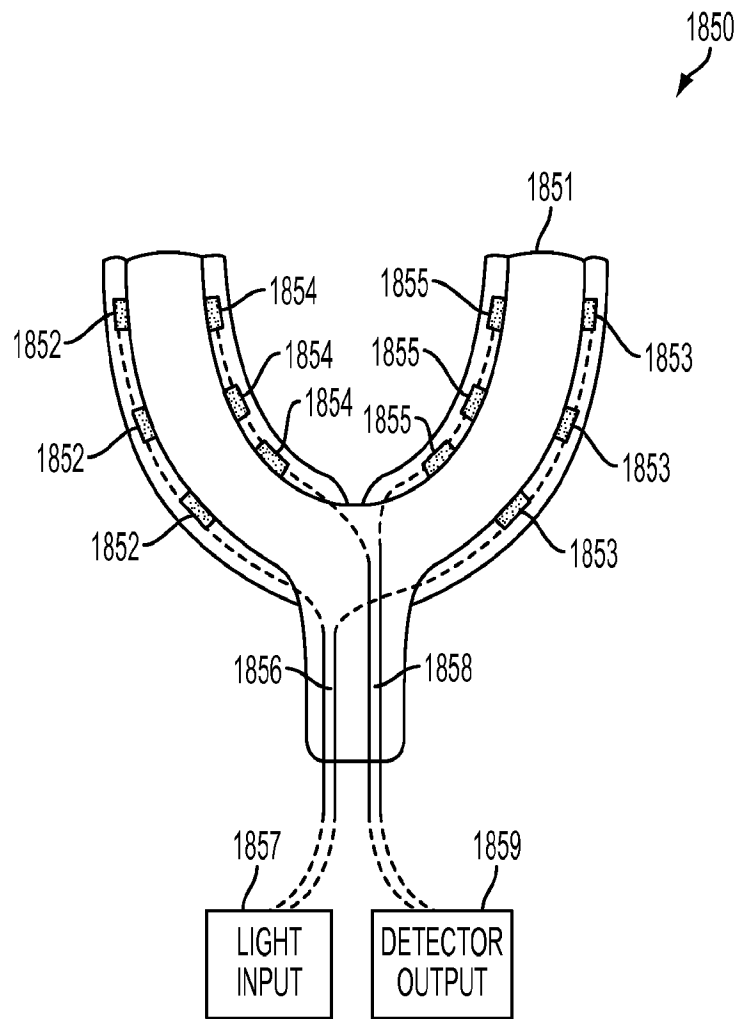

FIG. 18B

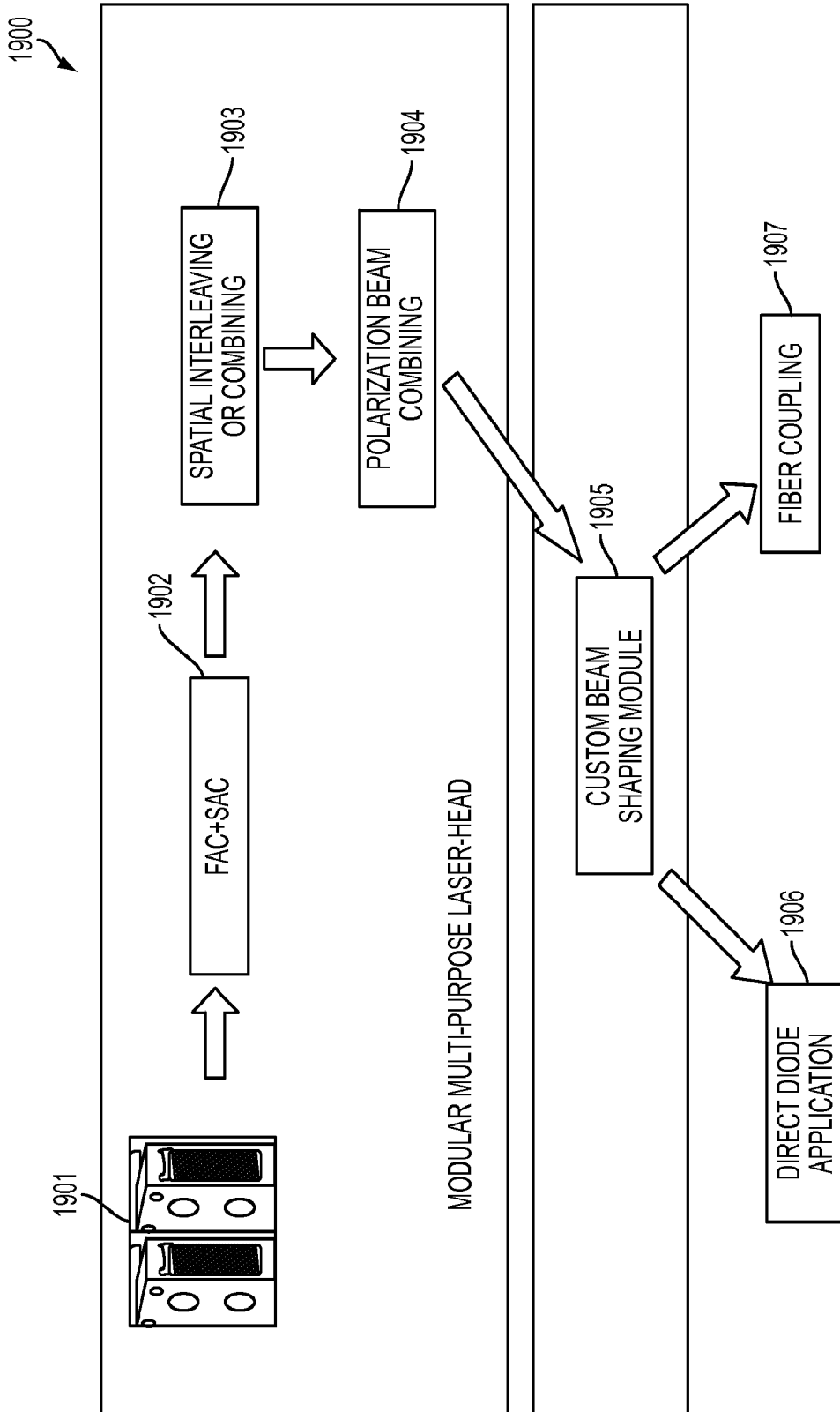

FIG. 19

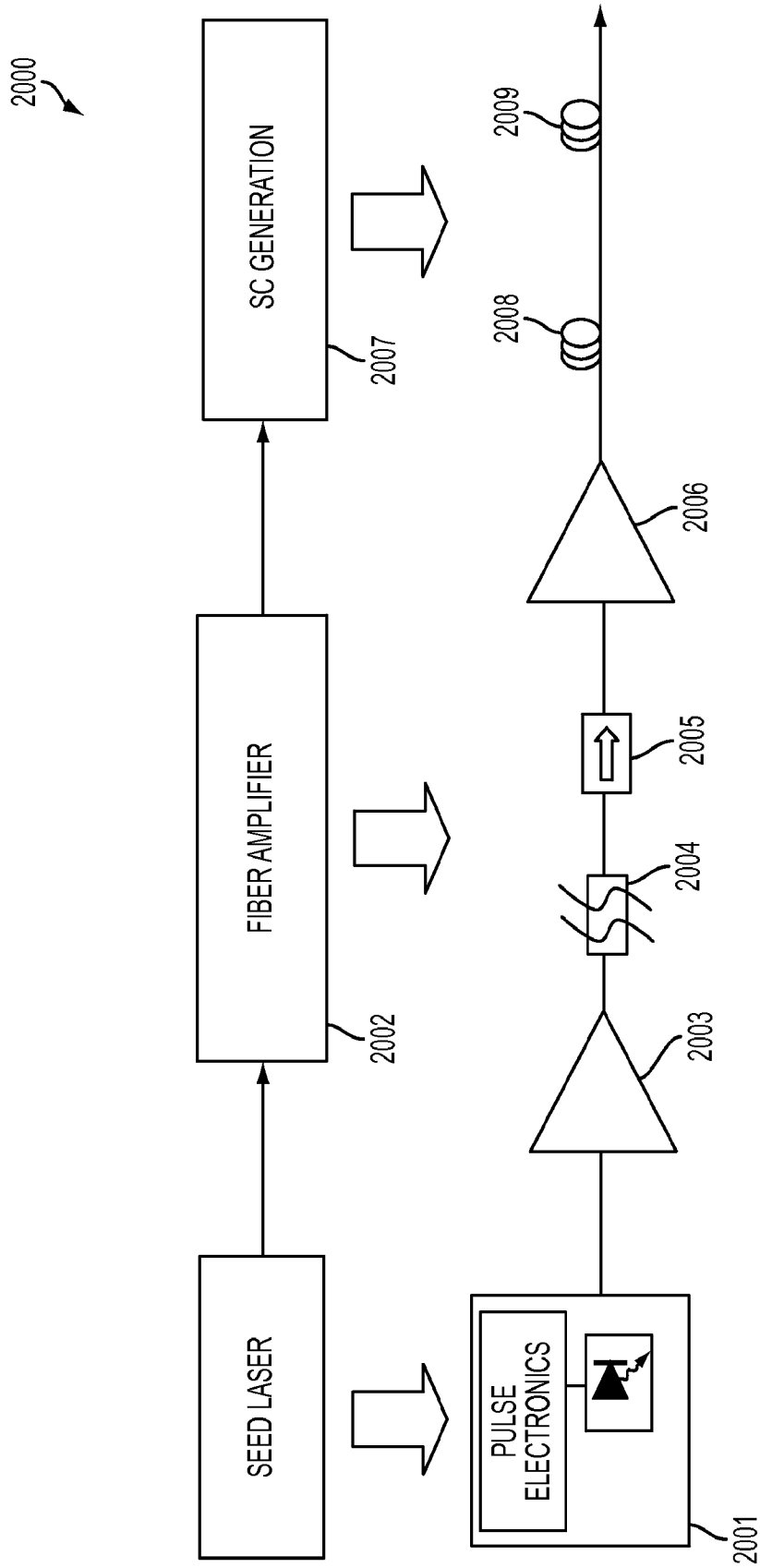

FIG. 20

2100 ↘

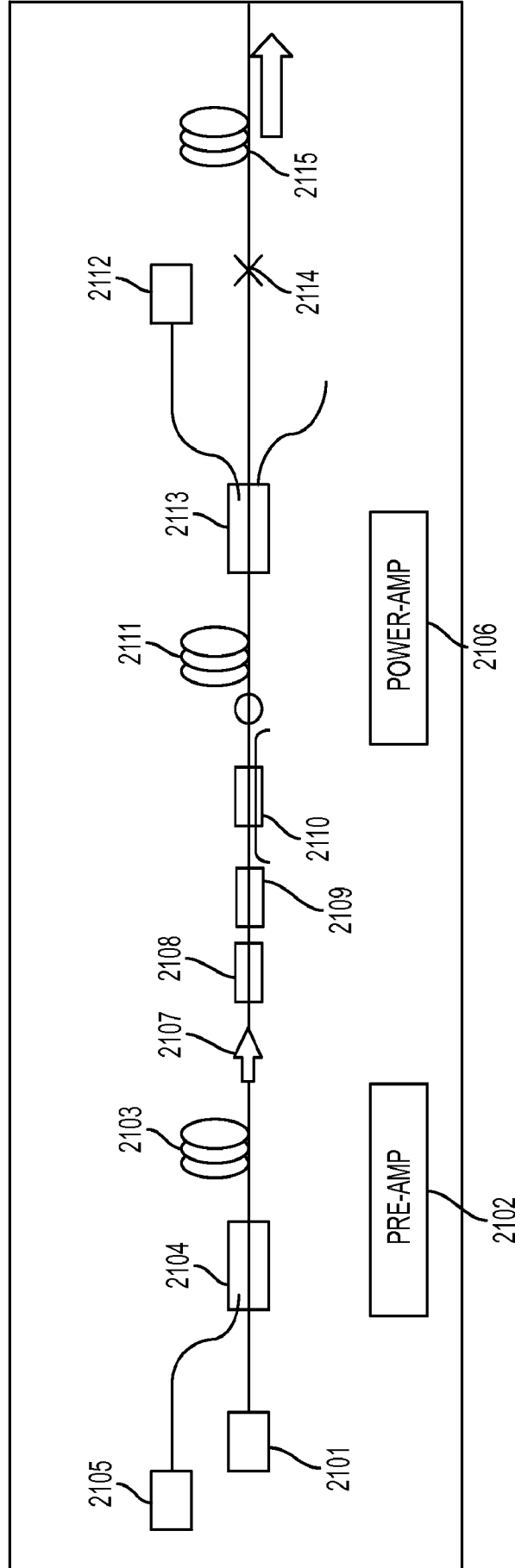

FIG. 21

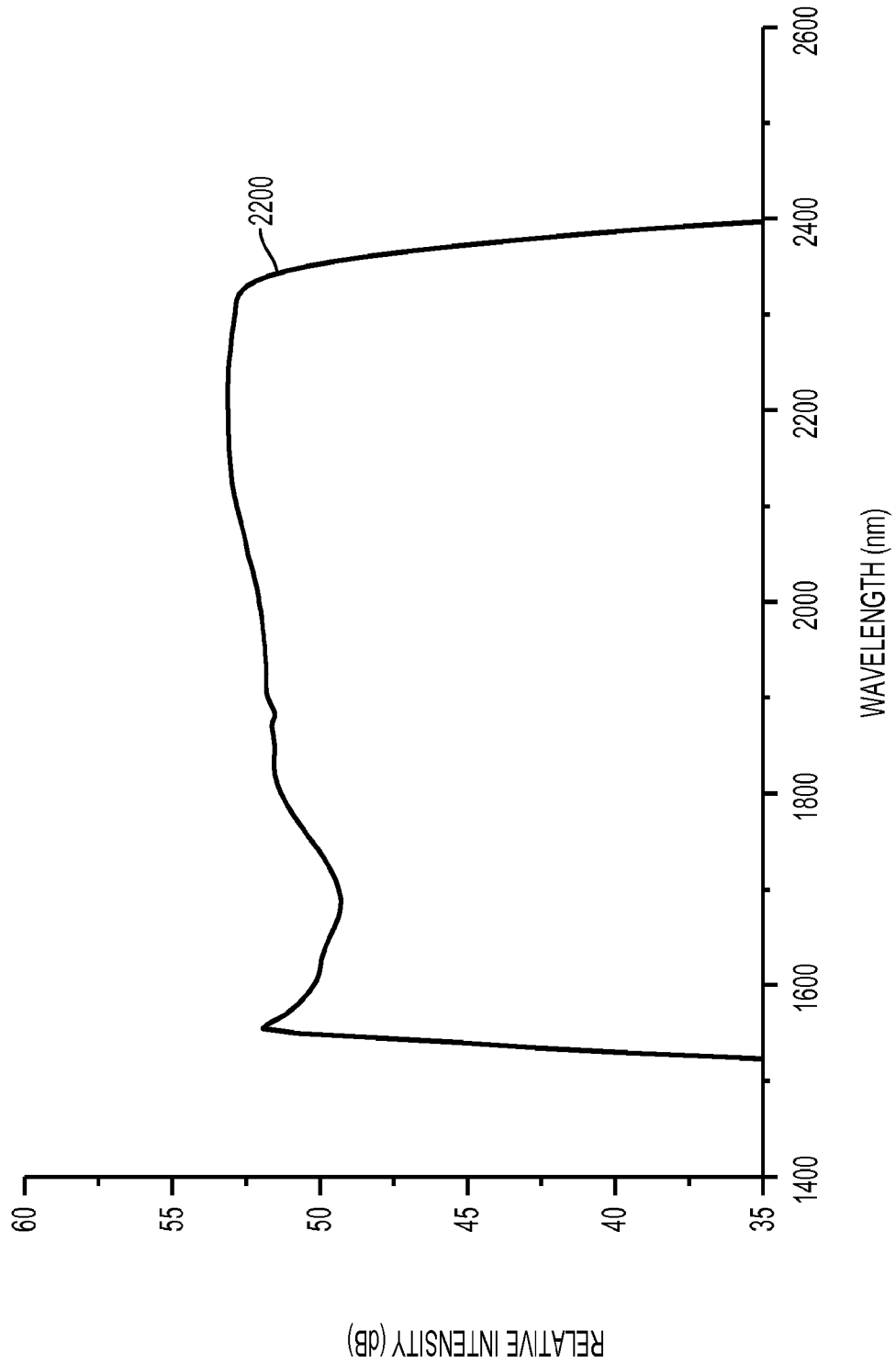

FIG. 22

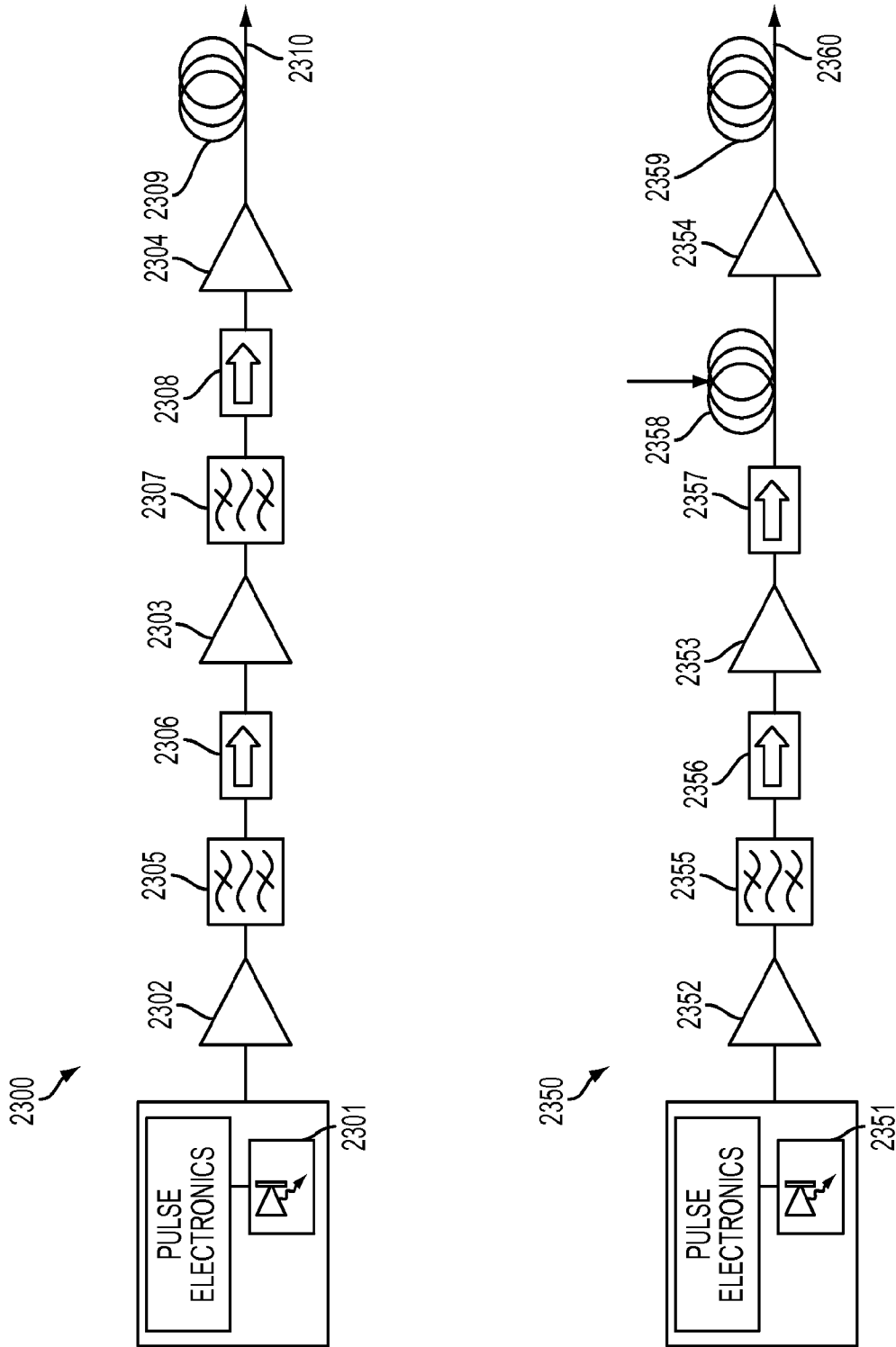

FIG. 23

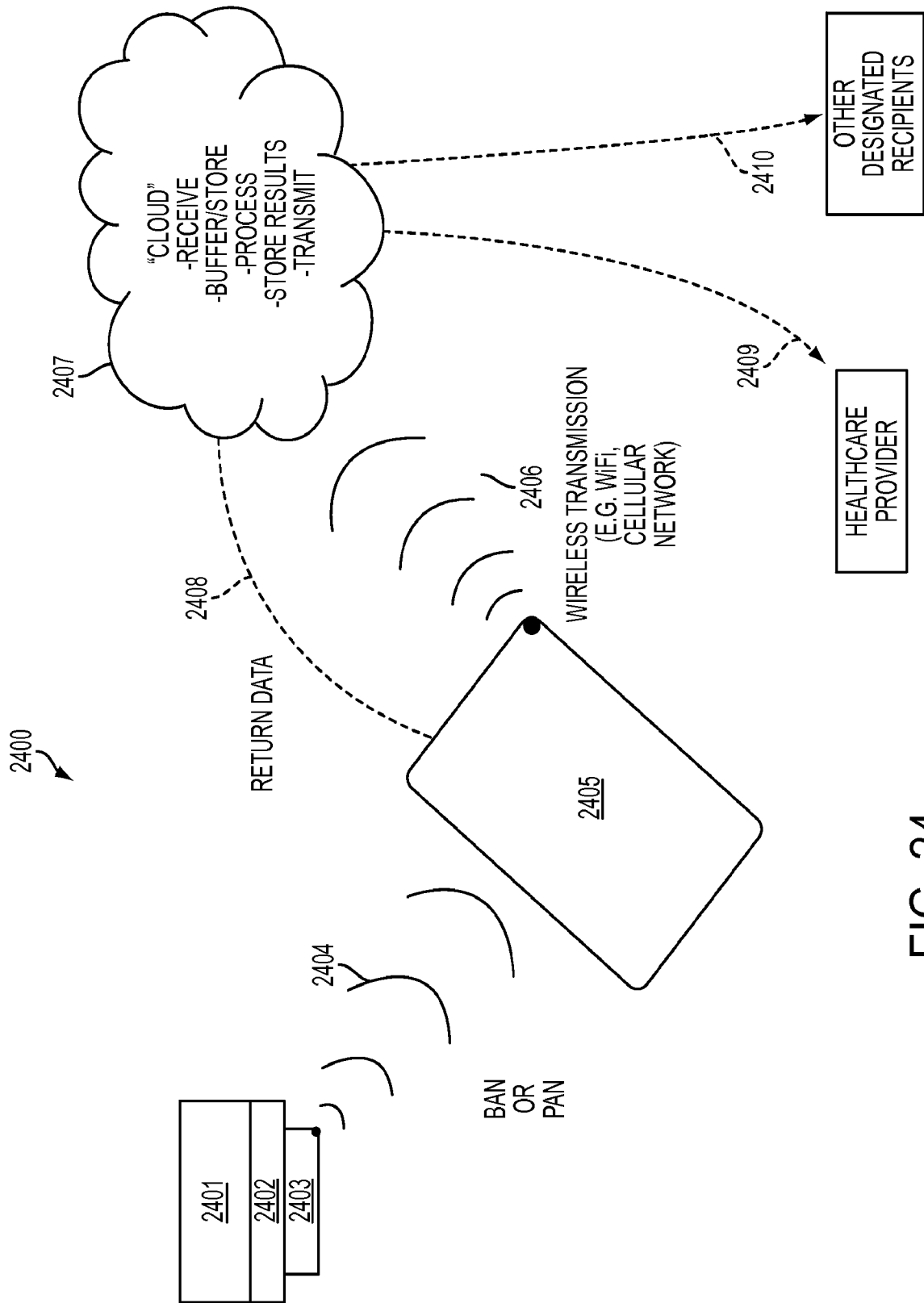

FIG. 24

INTERNATIONAL SEARCH REPORT

International application No.
PCT/US2013/075700**A. CLASSIFICATION OF SUBJECT MATTER****A61B 5/1477(2006.01)i**

According to International Patent Classification (IPC) or to both national classification and IPC

B. FIELDS SEARCHED

Minimum documentation searched (classification system followed by classification symbols)

A61B 5/1477; G06F 15/42; A61B 18/22; A61B 6/00; A61B 5/1455; A61B 5/00

Documentation searched other than minimum documentation to the extent that such documents are included in the fields searched

Korean utility models and applications for utility models

Japanese utility models and applications for utility models

Electronic data base consulted during the international search (name of data base and, where practicable, search terms used)

eKOMPASS(KIPO internal) & Keywords: near-infrared, laser, diagnosis, non-invasive, tooth, glucose and blood

C. DOCUMENTS CONSIDERED TO BE RELEVANT

Category*	Citation of document, with indication, where appropriate, of the relevant passages	Relevant to claim No.
X	US 2012-0239013 A1 (ISLAM, MOHAMMED N.) 20 September 2012 See abstract, paragraphs [0004]-[0015], [0059], [0136]-[0139], claims 30-40, and figures 7, 19-20.	1-20
A	US 2007-0021670 A1 (MANDELIS, ANDREAS et al.) 25 January 2007 See abstract, claims 1-28, and figure 1.	1-20
A	US 2011-0282167 A1 (RIDDER, TRENT et al.) 17 November 2011 See abstract, and claims 1-18.	1-20
A	US 5267152 A (YANG, WON S. et al.) 30 November 1993 See abstract, claim 1-3, and figure 1.	1-20
A	US 7356364 B1 (BULLOCK, AUDRA M. et al.) 08 April 2008 See abstract, and claims 14-20.	1-20

 Further documents are listed in the continuation of Box C. See patent family annex.

* Special categories of cited documents:

"A" document defining the general state of the art which is not considered to be of particular relevance

"E" earlier application or patent but published on or after the international filing date

"L" document which may throw doubts on priority claim(s) or which is cited to establish the publication date of another citation or other special reason (as specified)

"O" document referring to an oral disclosure, use, exhibition or other means

"P" document published prior to the international filing date but later than the priority date claimed

"T" later document published after the international filing date or priority date and not in conflict with the application but cited to understand the principle or theory underlying the invention

"X" document of particular relevance; the claimed invention cannot be considered novel or cannot be considered to involve an inventive step when the document is taken alone

"Y" document of particular relevance; the claimed invention cannot be considered to involve an inventive step when the document is combined with one or more other such documents, such combination being obvious to a person skilled in the art

"&" document member of the same patent family

Date of the actual completion of the international search

23 April 2014 (23.04.2014)

Date of mailing of the international search report

24 April 2014 (24.04.2014)

Name and mailing address of the ISA/KR

International Application Division
Korean Intellectual Property Office
189 Cheongsu-ro, Seo-gu, Daejeon Metropolitan City, 302-701,
Republic of Korea

Facsimile No. +82-42-472-7140

Authorized officer

CHOI, Sang Won

Telephone No. +82-42-481-8291



INTERNATIONAL SEARCH REPORT

Information on patent family members

International application No.

PCT/US2013/075700

Patent document cited in search report	Publication date	Patent family member(s)	Publication date
US 2012-0239013 A1	20/09/2012	CA 2623380 A1	31/05/2007
		CA 2623380 C	11/02/2014
		EP 1949151 A2	30/07/2008
		EP 1949151 A4	06/11/2013
		US 2009-0028193 A1	29/01/2009
		US 2009-0204110 A1	13/08/2009
		US 2014-0001364 A1	02/01/2014
		US 7519253 B2	14/04/2009
		US 8055108 B2	08/11/2011
		US 8391660 B2	05/03/2013
		WO 2007-061732 A2	31/05/2007
		WO 2007-061732 A3	28/02/2008
		US 2007-0021670 A1	25/01/2007
AU 2006-272332 B2	01/11/2012		
BR PI0613428 A2	30/10/2012		
CA 2615017 A1	25/01/2007		
CN 101262822 A	10/09/2008		
CN 101262822 B	20/11/2013		
EP 1906835 A1	09/04/2008		
EP 1906835 A4	31/07/2013		
IL 188747 D0	07/08/2008		
JP 2009-501579 A	22/01/2009		
JP 2013-172975 A	05/09/2013		
KR 10-2008-0051129 A	10/06/2008		
NZ 565509 A	26/08/2011		
US 8306608 B2	06/11/2012		
WO 2007-009234 A1	25/01/2007		
ZA 200801139 A	31/12/2008		
US 2011-0282167 A1	17/11/2011	CN 102365047 A	29/02/2012
		EP 2389100 A1	30/11/2011
		EP 2389100 A4	22/05/2013
		JP 2012-515630 A	12/07/2012
		US 2010-0010325 A1	14/01/2010
		US 8174394 B2	08/05/2012
		WO 2010-085716 A1	29/07/2010
US 5267152 A	30/11/1993	CN 1025410 C	13/07/1994
		CN 1051297 A	15/05/1991
		CN 1051297 C0	01/05/1994
		EP 0426358 A1	08/05/1991
		EP 0426358 B1	12/05/1999
		JP 03-146032 A	21/06/1991
		JP 05-081253 B	12/11/1993
		JP 10-000181 U	25/08/1998
		JP 2588468 Y2	30/10/1998
		KR 10-1992-0002091 A	28/02/1992
		KR 10-1993-0011586 B1	13/12/1993

INTERNATIONAL SEARCH REPORT

Information on patent family members

International application No.

PCT/US2013/075700

Patent document cited in search report	Publication date	Patent family member(s)	Publication date
US 7356364 B1	08/04/2008	None	