

April 3, 1945.

I. JEPSON

2,372,832

CONVECTION HEATER

Filed May 18, 1942

3 Sheets-Sheet 1

Fig. 1

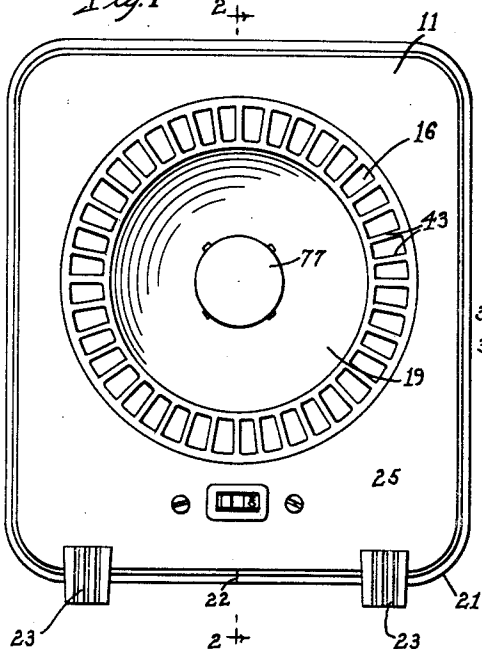

Fig. 3

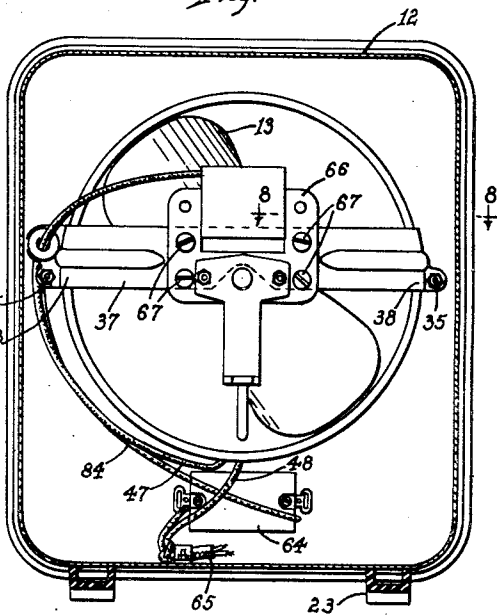

Fig. 7

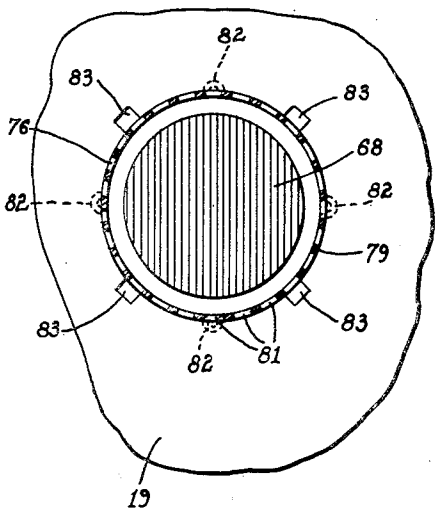
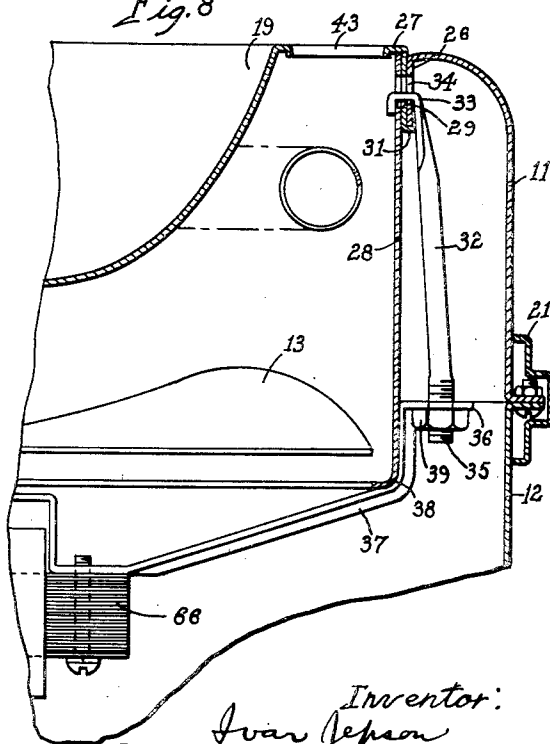

Fig. 8



Inventor:  
Ivar Jepson  
By McCanna, Winterrowd & Morshead

Attys.



April 3, 1945.

I. JEPSON

2,372,832

CONVECTION HEATER

Filed May 18, 1942

3 Sheets-Sheet 3

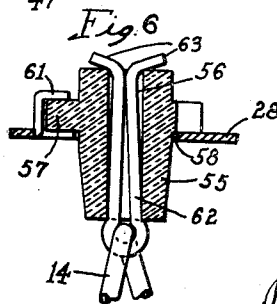
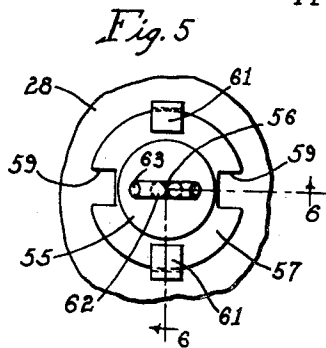
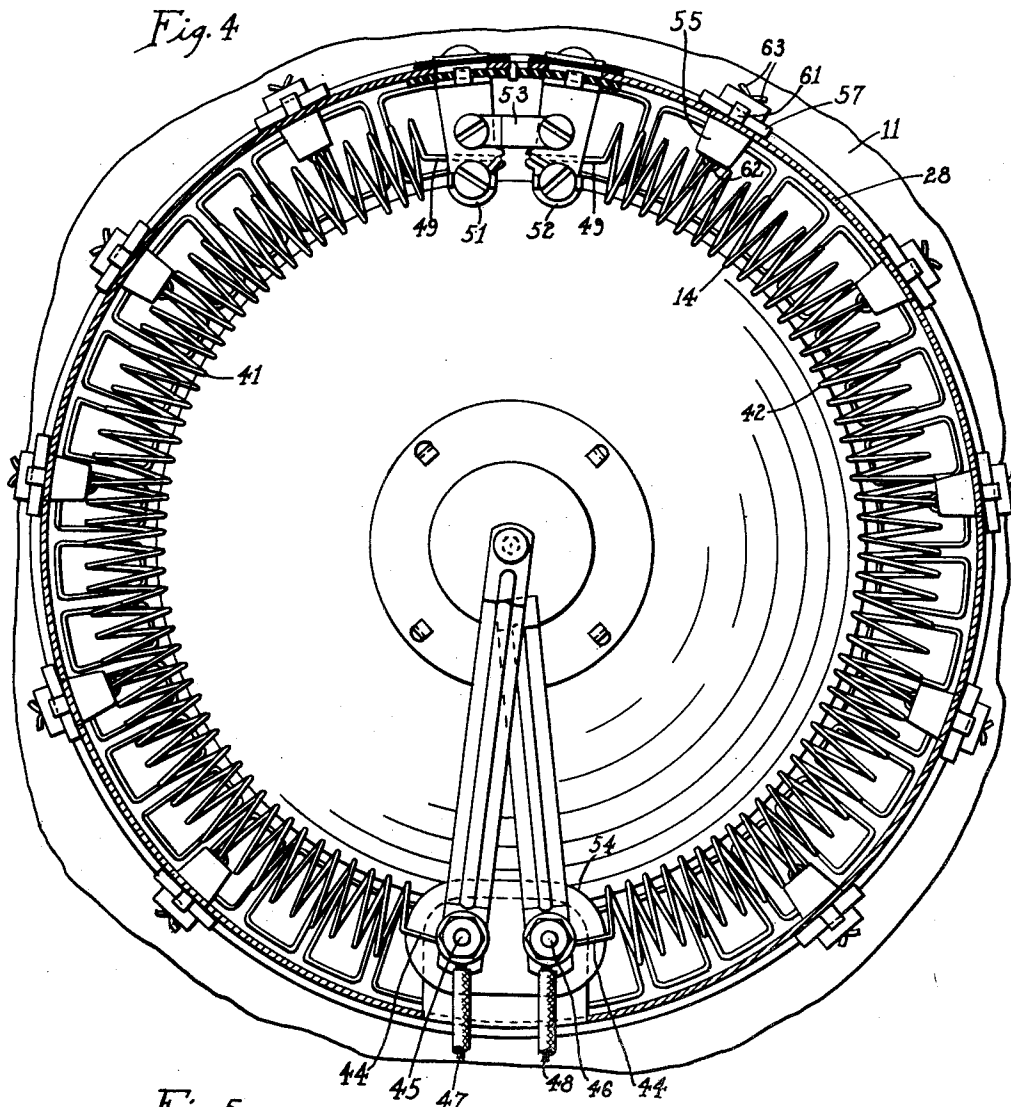

Inventor:  
Ivan Jepson  
By McAnna, Wintercorn & Morsbach  
Attys.

# UNITED STATES PATENT OFFICE

2,372,832

## CONVECTION HEATER

Ivar Jepson, Chicago, Ill., assignor to Chicago Flexible Shaft Company, Chicago, Ill., a corporation of Illinois

Application May 18, 1942, Serial No. 443,365

19 Claims. (Cl. 219—39)

This invention relates to electric heaters having means for causing circulation of the heated air. The invention has more particular reference to portable room heaters, but is applicable in certain of its phases to convection heaters designed for other purposes.

In the case of room heaters my invention distinguishes from the well known radiation type heater which invariably is provided with an exposed element adapted to be heated to red heat and which is objectionable because of its fire and danger hazards. Furthermore, because of the relatively high temperatures developed in the heating element of said radiation heaters, the mounting, connections, and casing are correspondingly subjected to high temperatures, thereby imposing construction difficulties. Also, the largest portion of the heat is concentrated to a small area and the heating is slow because distribution of the heat is dependent on radiation and reflection. This type of heater is therefore unsuitable or undesirable for many conditions and requirements of use.

The main object of the present invention is to provide a generally improved electric heater of the convection type particularly adapted for room heating but applicable in certain of its phases to other uses. I have aimed to provide a convection heater having a novel glow effect and a new result in that it combines certain advantages of both convection and radiant type heaters. According to my invention, relatively low temperature conditions and attendant advantages are utilized and at the same time I have provided means whereby a unique and impressive red glow emanates with the forced flow of heated air. This low temperature condition of the heater structure is desirable not only because of the practical elimination of fire and danger hazards, but also because of the more durable construction features permitted with this type of manufacture and the greater life of such a construction in actual use.

In the illustrative form of my invention herein disclosed I have provided a novel combination of delivering heated air from a localized outlet associated with an illuminating reflector the surface of which is treated to provide a unique glow effect, the assembly giving the impression that the heated air is emanating from a source of red heat. This localized air delivery may be arranged in other forms but in the present embodiment I have applied it to the front of a portable room heater in a particularly advantageous manner.

Another object of my invention is to provide an improved convection heater having features of construction making for economy in manufacture and service.

5 Another object is to provide an improved assembly of units such as a motor-driven fan, an electric heater, and a glow reflector, in a convection type heater.

10 Another object is to provide an improved electric heater.

Other objects and attendant advantages will be appreciated by those skilled in this art as the invention becomes better understood by references to the following description when considered in connection with the accompanying drawings, in which:

Figure 1 is a front view of an electric heater embodying my invention;

15 Fig. 2 is an enlarged vertical section through the heater substantially on the section line 2—2 of Fig. 1;

Fig. 3 is a section substantially on the section line 3—3 of Fig. 2, on a scale similar to Fig. 1;

20 Fig. 4 is a fragmentary section substantially on the section line 4—4 of Fig. 2;

Fig. 5 is an outer face view of one of the insulation mountings for the heater element;

Fig. 6 is a section substantially on the section line 6—6 of Fig. 5;

30 Fig. 7 is a section substantially on the section line 7—7 of Fig. 2; and

Fig. 8 is a fragmentary section substantially on the section line 8—8 of Fig. 3.

In the illustrative embodiment shown in the drawings, an outer casing is provided consisting of a front casing member 11 and a rear casing member 12, within which is supported a motor-driven fan 13 and an electric heater 14 arranged so that the fan draws air through inlet louvres 15 in the rear casing member and forces the air through the heater and out through a relatively narrow annular outlet opening 16 in the front casing member for distribution in the room or space to be heated. The casing members 11 and 12, joined by abutting flanges 17 held together by screws 18, are separable to permit access to the motor and heater assemblies and other interior parts. In this embodiment I prefer to support these assemblies on the front member in coaction with a glow reflector 19 and its associated parts, so that by removal of the rear casing member these assemblies and associated parts are accessible. A decorative band 21 split at 22 encases the connecting flanges 17. The casing may be supported by any suitable means, pref-

erably for portability, as by base blocks 23 connected to the casing members by screws 24. The front wall 25 of the front casing member has an annular opening therein defined by an inwardly bent flange 25 on which is seated and supported an inner casing assembly which in turn supports the motor and heater assemblies above mentioned. The inner casing may be said to consist of a front member 27 in which the opening 16 and reflector 19 are formed, and a separate rear sleeve member 28 open at its opposite ends and defining the outer wall of an air conduit which leads to the outlet opening 16. This sleeve member also provides a support for the electric heater and the motor-driven fan. The front inner casing member has a rearwardly bent annular flange 29 which seats in the flange 27 and has an outwardly turned thrust shoulder 31 against which the flange 26 abuts. The sleeve member 28 seats at its forward end on the flange 29 and abuts against the inner front member 27. The casing members 11, 27 and 28 are detachably clamped in this relation by a pair of draw bolts 32 each having a hooked end 33 passing through aligned openings 34 in these members and having a threaded end 35 passing through a flange 36 of a bracket 37 which spans the rear open side of the sleeve member 28 as shown in Fig. 3 and is fixed thereto as by welding at the corners 38. A nut 39 threaded on the rear end of each bolt 32 is adapted to be tightened to draw the inner casing member 27 and the front outer casing member 11 together and consequently clamp them to the interposed flange member 29. As shown in Fig. 8 the opening 34 in the flange 26 is the smallest so that each hooked end pulls inwardly on this flange.

The electric heater 14, best shown in Figs. 4, 5 and 6, consists of two elements 41 and 42 of suitable resistance wire preferably coiled and each supported in a semi-circular form so that together they make up an annular element conforming substantially with the diameter of the annular opening 16. As shown in Fig. 2 the heater 14 is located in the air conduit or channel defined by the sleeve member 28 and the reflector 19 for the purpose of heating the air forced through this conduit by the fan 13. The heated air is discharged from said conduit forwardly through the opening 16. This opening 16 may be provided with suitable guard members 43 as a protection against accidental access to the heater elements from the front. The heater elements have ends 44 connected to terminal posts 45-46 to which current supply leads 47 and 48 are connected, and opposite ends 49 connected to the conductor bars 51-52 which are connected by a fuse element 53 in keeping with the teachings of Browning patent No. 2,015,251. The terminal posts 45-46 are mounted through suitable insulation on a flat flange 54 turned inward from the sleeve member 28 and the conductor bars 51-52 are mounted through suitable insulation on said sleeve member diametrically opposite from the terminal posts. Each coil element is further supported from the sleeve member 28 through a plurality of individual insulation blocks 55. These insulation blocks are arranged at spaced intervals along each coil so as to conform the coil to the desired arcuate shape and relation to the outlet opening 16. As shown in Figs. 5 and 6, each insulation block has a cylindrical body portion provided with a through opening 56 and with a projecting supporting flange 57. Each insulation block is inserted at one end through an open-

ing 58 in the sleeve member 28, from the outer side thereof, until limited by its flange 57 seating against the sleeve member. Each flange 57 is slotted at 59 to receive retaining lugs 61 pressed outwardly from the sleeve member, so that when the insulation block is seated it can be moved rotatively to disalign its slots with respect to the retaining lugs, as shown in Fig. 5, to thereby engage the block against displacement. Each insulation block is connected to the coil by means of a wire staple 62. These wire staples are engaged over the adjacent convolution of the coil and the ends of the staple are passed through the opening 56 and bent back at 63 to lock the coil on its insulation support. The opening 56 in each insulation block is elongated in cross section to prevent rotative displacement of the staple. The heater is connected to a suitable supply circuit including an "on-off" switch 64 mounted within the outer casing with its manually operable switch member projecting through the front wall thereof, this switch being connected to the heater lead wire 47-48 and to a suitable supply cord 65.

The means for causing forced circulation of air through the heater may be of any suitable or desired construction and in this embodiment I employ a motor unit designated generally by 66 attached to the bracket 37 at the rear thereof by screws 67 and carrying the fan 13 forward of the bracket. The motor unit shown is similar to that disclosed in DeMonte Patent No. 2,245,433 and is desirable because of its high efficiency and good lubrication features which make it particularly well adapted for economy and long life in an appliance of this kind.

The means for producing the glow effect in coaction with discharge of the heated air will now be described. This includes the reflector 19, above mentioned, the front or concave face of which is treated or prepared to give it a fine, stippled effect to produce a uniform red glow by reflection of light rays from an illuminating means such as a lamp bulb 68 colored red. I have discovered an effective glow is obtained by sand-blasting the surface of the reflector after having finished the entire reflector member, in this case the entire front inner casing member 27, by chromium plating. The lamp bulb 68 has the usual threaded end screwed into a contact sleeve 69, which is held in position in an insulation socket member 71 by means of a center contact member 72 which in turn is screwed to the member 71 by a connector rivet 73. The socket member 71 has an outstanding flange 74 fixed to the reflector member by means of retaining lugs 75 pressed rearwardly from said reflector member. These retaining lugs 75 hold the socket member 71 in fixed position with its socket portion extending forwardly through a center opening 76 in the reflector. A removable guard and light shade 77 serves to protect the lamp bulb and to baffle it from view and also to permit substantially unrestricted passage of its rays to the reflector face. This guard comprises a substantially imperforate front cap 78 and a sleeve 79 having closely spaced elongated openings 81 entirely around the lamp so as to allow a full flow of the radiant rays from the lamp to the reflector face. The inner end of the sleeve has out-turned retaining lugs 82 adapted to be inserted into correspondingly positioned slots 83 in the edge of the opening 76 and to engage behind the inner edge of the reflector by turning the sleeve, thereby detachably holding the lamp guard in position.

The electric circuit may be of any suitable arrangement such, for example, as with the heater 14 and the lamp 68 in parallel and the motor 66 in series with the heater, controlled by the manual switch 64 and further controlled by the fuse 53. As shown in Fig. 3, the conductor wire 84 connects the switch 64 in series with the motor which in turn is connected by the wire 47 to the heater. This fuse prevents overheating from misuse or accidental use of the heater; for example, in the event the heater is covered or its inlet or its outlet openings are closed, or in the event the heater is turned on its front or back, obstructing the flow of air.

In operation the motor-driven fan produces forced circulation of air through the casing and the air is heated by the electric heater 14. The heated air is discharged through the outlet 16 and distributed into the room to be heated. This discharge of heated air is designed to be localized by the shape of the outlet opening and the discharge conduit according to the purpose for which the heater is intended to serve, to obtain the desired distribution and circulation of the heated air in the room. The heating is, therefore, mainly by convection. However, the discharge outlet 16 is in such close proximity and coaction with the glow reflector 19 as to give the impression that the heated air is being delivered directly from the reflector portion which has the appearance of a substantial surface heated to a red, somewhat luminous glow, simulating the glow of a resistance element heated to red heat. Thus I deliver a substantial flow of heated air so that the convection currents are felt at a considerable distance from the heater and this is done with a relatively low temperature heater while at the same time giving the visual impression of a high temperature heating element. My invention, however, eliminates disadvantages of heater which depend on heating elements maintained at a red heat and consequently at a relatively high temperature. Such high temperature affects the element mountings and connections and imposes special protective measures if fire and personal danger hazards are to be avoided. Also, such high temperature elements cause the burning of small dust and other particles in the air with the result that they are apt to cause an offensive odor. Furthermore, high temperature heaters of the radiant type also are dangerous in the home particularly where there are small children who are apt to be burned by contact with the exposed heating element. These disadvantages are practically eliminated by my improved heater; and, moreover, my improved heater gives greater distribution of heat when used for room heating.

While I have shown a particular embodiment of my invention it will be understood that I do not wish to be limited thereto since many modifications may be made and I therefore contemplate by the appended claims to cover any such modifications as fall within the true spirit and scope of my invention.

I claim:

1. A convection heater having, in combination, a front air discharge opening, a low temperature heating element behind said discharge opening, means for forcing air across said heating element and forwardly through said discharge opening, a concave face reflector adjoining said discharge opening and having an unobstructed light diffusing surface facing in the direction of

the heated air discharge, and a light bulb for directing colored light rays to said reflector surface to produce a red glow effect simultaneously with said heated air discharge.

2. A convection heater having, in combination, a casing, an annular concave face reflector in the front of the casing at the rear of the reflector facing forwardly, an air conduit in the casing having a relatively narrow air outlet opening circumferentially around the reflector, a motor-driven fan arranged for forcing air through said conduit and discharging the air through said outlet opening, a heating element within said conduit in the path of said forced air for heating said air, and essentially light emitting means for directing light rays against the face of said reflector to produce a red glow effect simultaneously with the delivery of said heated air whereby whatever infra-red radiation is emitted from said light means is inconsequential in degree and the hazard of burning by accidental contact therewith is avoided.

3. An electric heater having, in combination, a casing provided at its front with a relatively narrow annular air outlet opening, an annular concave face reflector centrally within said opening facing forwardly and with its front end substantially flush with said outlet opening, an air conduit circumferentially around said reflector leading to said air outlet, a heating element located in said conduit, circumferentially around the reflector, means for forcing air through said conduit to be heated by said heating element and discharged forwardly through said outlet opening circumferentially around the reflector, and means including a light bulb within the reflector for producing a red glow effect substantially throughout its concave face simultaneously with the discharge of said heated air through said outlet opening.

4. An electric heater comprising an outer casing having an annular opening in its front and an air inlet opening in its back portion, an inner annular casing disposed in said front opening and extending inwardly into the outer casing, the inner casing forming an air conduit having an inlet at its rear end and an outlet at its front end, an annular concave face reflector centrally located in said inner casing with its concave face forward, a heating element in said air conduit extending circumferentially around the reflector at the rear of said air outlet opening, a motor-driven fan arranged for forcing air through said conduit across said heating element and for discharging the heated air through said outlet opening, and means in the reflector for illuminating its concave face to produce a glow effect simultaneously with the discharge of heated air through said outlet opening, said parts being constructed and arranged so that the motor-driven fan, the heating element, the reflector, and the illuminating means are associated with the inner casing so as to constitute therewith a unit of assembly separate from the outer casing and removable as a unit from said outer casing.

5. An electric heater comprising an outer casing having an air inlet opening in its back and an air outlet opening in its front, an inner casing within the outer casing having an open rear end and forming an air conduit leading to said outlet opening, a motor-driven fan within the outer casing arranged for forcing air through said conduit and discharging it forwardly through said outlet opening, a heating element in said conduit for heating said air, a reflector in the front of the outer casing extending inwardly into said inner casing, and means for illuminating the face of

said reflector to produce a glow effect simultaneously with the discharge of heated air through said outlet opening, the heating element comprising a coil arranged circumferentially around the reflector and supported from the inner casing, and the air outlet opening being located in front of the heater coil and circumferentially around the reflector.

6. An electric heater having a casing, a glow reflector in the front thereof having a forwardly facing annular concave reflector face, an air outlet opening circumferentially around the reflector, an annular casing sleeve within the first mentioned casing open at its rear end and associated at its front end with the discharge opening so as to define the outer wall of an air conduit leading to said discharge opening, the inner wall of said air conduit being defined by the reflector, a heating element in said air conduit, a motor-driven fan within the casing for forcing air through said conduit where it is heated by said heating element and from which it is discharged through said outlet opening, and means including a light bulb in the center of said reflector for illuminating said reflector face to produce a glow effect simultaneously with the discharge of said heated air.

7. An electric heater having a casing, a reflector in the front wall thereof, an air outlet opening in said front wall around the reflector, a heating element within the casing, a motor-driven fan within the casing for circulating air within the casing to be heated by said heating element and forcing the heated air out through said outlet opening, and means for impinging red light rays on the reflector surface, said reflector surface being stippled to produce a glow effect from said rays.

8. An electric heater having a casing, a reflector in the front wall thereof, an air outlet opening in said front wall around the reflector, a heating element within the casing, a motor-driven fan for circulating air within the casing to be heated by said heating element and forcing the heated air out through said outlet opening, a red covered lamp bulb, a socket for the lamp bulb at the center of the reflector, a guard substantially enclosing the lamp bulb and shaped to allow passage of the colored light rays to the reflector surface, and a circuit connecting the motor-driven fan, heating element and light bulb for simultaneous operation thereof.

9. An electric heater comprising an outer casing formed of a front casing member having a front wall and continuous side walls forming an enclosure and a rear casing member having a rear wall and continuous side walls forming an enclosure complementary to that formed by the side walls of the front casing member, means detachably connecting the side walls of the front and rear casing members one to the other, an inner casing member within the outer casing defining the outer wall of an annular air conduit having an inlet at the rear end and an outlet at the front end, the inner casing member being arranged so that its outlet is through the front of the outer casing, a forwardly facing reflector located in the front of the outer casing extending inwardly into the air conduit formed by the inner casing member, a motor-driven fan for forcing air forwardly through said conduit, a heating element located in said conduit for heating said air, and essentially light emitting means located in the reflector for producing a glow effect on the

reflector face simultaneously with the operation of the motor-driven fan and the heating element.

10. An electric heater having a one-piece front member shaped to provide an annular concave face reflector and an air discharge opening circumferentially around said reflector and an annular rearwardly projecting flange circumferentially around said discharge opening; a cylindrical casing sleeve having its front end telescoping said flange for support thereon; said sleeve together with the back of the reflector forming an air conduit leading to said discharge opening; a heating element in said air conduit arranged circumferentially around the reflector; a motor-driven fan mounted on the rear end of the casing sleeve for forcing air forwardly through said conduit whereby the air is heated by said heating element and discharged through the discharge opening at the front of the heater; and means including a light bulb within the concave side of the reflector for illuminating the concave face thereof to produce a glow effect simultaneously with the discharge of said heated air.

11. An electric heater having a support, a heating element of resistance wire, and means for mounting the heating element on the support comprising a plurality of individual insulators, the support having an opening for the reception of each insulator, each insulator having a projecting flange adapted to seat against the support when the insulator is inserted into said opening, each flange having one or more slot openings in its peripheral edge, one or more retaining lugs on the support adapted to pass through the corresponding slot openings when the insulator is inserted and to retain the insulator against endwise displacement from said inserted position, each insulator having a through opening transverse to its flange, a wire staple for each insulator engaged over the heating element wire so that said wire is held in the head of the staple, the ends of the staple being passed through the opening in the insulator and bent back at the end thereof into locking engagement with the adjacent end of the insulator.

12. An electric heater having an annular support, a pair of terminal binding posts insulated on said support, a pair of connectors insulated on the support diametrically opposite from said binding posts, a pair of heating elements each comprising a resistance wire connected at one end to one of said binding posts and at its opposite end to one of said connectors, insulators connecting each resistance wire to the support at points spaced apart longitudinally of the wire and arranged to conform the wire to the arcuate shape of the support, and a fuse connecting the said connectors.

13. A convection heater having, in combination, an electric heater, means for causing forced circulation of air to be heated, a casing through which the heated air is forced, the casing having an annular outlet opening through which the heated air is discharged, an annular concave face reflector located centrally within said outlet opening facing in the direction of the air delivery from said outlet, a lamp bulb mounted centrally within the reflector, a combined guard and light shade substantially covering the lamp bulb except for openings arranged to permit the passage of light rays to the reflector, and means providing a red glow on the surface of the reflector in response to said light rays simultaneously with the delivery of heated air through said outlet opening.

14. A convection heater having an air conduit

terminating in an annular discharge opening at its front, a reflector located centrally within said discharge opening having a front concave reflector face, a low temperature heating element in said conduit, means for forcing air through said conduit across said heating element and for discharging the heated air forwardly through said discharge opening, the concave face of the reflector having a light diffusing surface, and means including a light bulb within the concave side of the reflector for applying colored light rays to said surface to produce a red glow effect in the area within said discharge opening simultaneously with the discharge of heated air through said opening.

15. A convection heater having an annular air discharge opening and a forwardly facing glow reflector within said opening, a heating element behind said discharge opening, means for forcing air across said heating element and forwardly through said discharge opening, the reflector face having an unobstructed light diffusing surface, and a light bulb in the center of said reflector for directing colored light rays to said light diffusing surface to produce a red glow effect simultaneously with the discharge of said heated air.

16. A convection heater having, in combination, an air discharge opening and a glow area in juxtaposition, means for delivering a forced flow of heated air through said discharge opening, and means for emitting essentially light in said glow area to present to the eye a glow effect and so that whatever infra-red radiation is emitted from said light means is inconsequential in degree and the hazard of burning by accidental contact therewith is avoided.

17. A convection heater having, in combination, a face composed substantially entirely of a reflector area and an air discharge area in juxtaposition, means within the heater for heating air and discharging it through said air discharge area including an electric heating element, and

means within the reflector area for emitting essentially light for impingement against the surface of the reflector whereby to present to the eye a glow effect defined by the area of the reflector and whereby whatever infra-red radiation is emitted from said light means and the reflector surface is inconsequential in degree and the hazard of burning by accidental contact therewith is avoided.

18. A convection heater having, in combination, a face composed substantially entirely of a visible glow area and an air discharge area in juxtaposition, means within the heater for heating air and discharging it through said air discharge area including an electric heating element of large surface area to watts ratio, and means providing said visible glow area including a reflector surface and means for emitting essentially light for impingement against said surface whereby to present to the eye a glow effect defined by the area of said surface and whereby whatever infra-red radiation is emitted from said light means and said surface is inconsequential in degree and the hazard of burning by accidental contact therewith is avoided.

19. A convection heater having, in combination, an air discharge opening and a reflector within the area defined by said opening, a heating element behind said opening, means for forcing air across said heating element and through said discharge opening, and means for emitting essentially light for impingement against the reflector surface, said light means and said reflector surface being constructed and arranged so that the light rays reflected by said reflector are of color to present to the eye a glow effect defined by the area of the reflector and so that whatever infra-red radiation is emitted from said light means and the reflector surface is inconsequential in degree and the hazard of burning by accidental contact therewith is avoided.

IVAR JEPSON.

CERTIFICATE OF CORRECTION.

Patent No. 2,372,832.

April 3, 1945.

IVAR JEPSON.

It is hereby certified that error appears in the printed specification of the above numbered patent requiring correction as follows: Page 3, second column, line 7, claim 2, strike out the words "at the rear of the reflector" and insert the same after "casing", line 8, same claim; page 4, first column, line 34, claim 7, for "forcng" read --forcing--; and that the said Letters Patent should be read with this correction therein that the same may conform to the record of the case in the Patent Office.

Signed and sealed this 11th day of December, A. D. 1945.

Leslie Frazer

First Assistant Commissioner of Patents.

(Seal)