

6 1 2 9 7 7

SPRUSON & FERGUSON

COMMONWEALTH OF AUSTRALIA

PATENTS ACT 1952

CONVENTION APPLICATION FOR A STANDARD PATENT

We, NEC Corporation, of 33-1, Shiba 5-chome, Minato-ku, Tokyo, Japan hereby apply for the grant of a standard patent for an invention entitled:

"TRANSMITTER/RECEIVER APPARATUS"

which is described in the accompanying complete specification.

DETAILS OF BASIC APPLICATION

Number of Basic Application:-  
118908/1986

Name of Convention Country in which Basic Application was filed:-  
Japan

Date of Basic application:-  
23 May, 1986

Our address for service is:-

C/- Spruson & Ferguson  
Patent Attorneys  
Level 33 St Martins Tower  
31 Market Street  
Sydney New South Wales Australia

DATED this TWENTY-FIRST day of MAY 1987

NEC Corporation

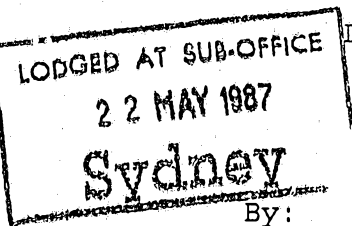
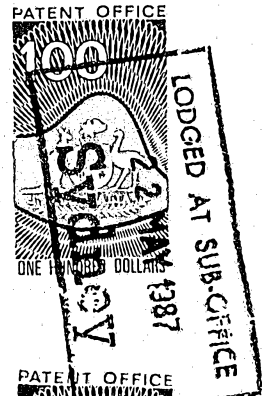

By:

*M. J. Anderson*

Registered Patent Attorney.

TO: THE COMMISSIONER OF PATENTS  
AUSTRALIA

SBR/JS/0075T

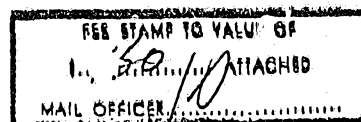

COMMONWEALTH OF AUSTRALIA  
THE PATENTS ACT 1952  
DECLARATION IN SUPPORT OF A  
CONVENTION APPLICATION FOR A PATENT

AUSTRALIA  
CONVENTION  
STANDARD  
& PETTY PATENT  
DECLARATION  
SFP4

In support of the Convention Application made for a  
patent for an invention entitled:

f Invention "TRANSMITTER/RECEIVER APPARATUS"

I/We Susumu Uchihara

Full name(s) and  
address(es) of  
Declarant(s)

-of c/o NEC Corporation of 33-1, Shiba 5-chome, Minato-ku,  
Tokyo, Japan

do solemnly and sincerely declare as follows:-

Full name(s) of  
Applicant(s)

- ~~1. I am/We are the applicant(s) for the patent~~  
(or, in the case of an application by a body corporate)
- 1. I am/We are authorised by NEC Corporation

the applicant(s) for the patent to make this declaration on  
its/their behalf.

- 2. The basic application(s) as defined by Section 141 of the  
Act was/were made

Basic Country(ies)

in Japan

Priority Date(s)

on the 23rd May, 1986

Basic Applicant(s)

by NEC Corporation

Full name(s) and  
address(es) of  
inventor(s)

- ~~3. I am/We are the actual inventor(s) of the invention referred  
to in the basic application(s)~~  
(or where a person other than the inventor is the applicant)

- 3. Osamu Yamamoto

of c/o NEC Corporation of 33-1, Shiba 5-chome, Minato-ku,  
Tokyo, Japan

(respectively)

is/are the actual inventor(s) of the invention and the facts upon  
which the applicant(s) is/are entitled to make the application are  
as follows:

Set out how Applicant(s)  
derive title from actual  
inventor(s) e.g. The  
Applicant(s) is/are the  
assignee(s) of the  
invention from the  
inventor(s)

The said applicant is the assignee of the actual inventor.

- 4. The basic application(s) referred to in paragraph 2 of this  
Declaration was/were the first application(s) made in a Convention  
country in respect of the invention(s) the subject of the application.

Declared at Tokyo, Japan this 21st day of April, 1987.  
NEC CORPORATION

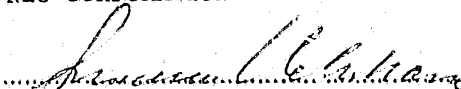
  
Signature of Declarant(s)  
Susumu Uchihara  
General Manager, Patents Division

To: The Commissioner of Patents

11/81

**(12) PATENT ABRIDGMENT (11) Document No. AU-B-73306/87**  
**(19) AUSTRALIAN PATENT OFFICE (10) Acceptance No. 612977**

- (54) Title  
TRANSCEIVER
- International Patent Classification(s)  
(51)<sup>4</sup> H04B 001/50 H04B 015/00 H04B 007/185
- (21) Application No. : 73306/87 (22) Application Date : 22.05.87
- (30) Priority Data
- (31) Number (32) Date (33) Country  
61-118908 23.05.86 JP JAPAN
- (43) Publication Date : 26.11.87
- (44) Publication Date of Accepted Application : 25.07.91
- (71) Applicant(s)  
NEC CORPORATION
- (72) Inventor(s)  
OSAMU YAMAMOTO
- (74) Attorney or Agent  
SPRUSON & FERGUSON , GPO Box 3898, SYDNEY NSW 2001
- (56) Prior Art Documents  
EP 246658
- (57) Claim

1. A transmitter/receiver apparatus comprising a first and a second device which are interconnected by a single signal cable;

said first device comprising:

a local oscillator for generating a local oscillation frequency at a predetermined position between a transmit and a receive frequency band;

a transmit frequency converter connected to said local oscillator for converting a transmit intermediate frequency band into said transmit frequency band based on said local oscillation frequency such that a transmit image frequency band of said transmit frequency band does not overlap said receive frequency band;

a receive frequency converter connected to said local oscillator for converting, based on the local oscillation frequency, the receive frequency band into a receive intermediate frequency band, which does not overlap the transmit intermediate frequency band, such that a receive image frequency band of said receive intermediate frequency band does not overlap the transmit frequency band, said frequency converter and said receive frequency converter being disposed separately from said local oscillator; and

a first frequency multiplexer connected between one end of the signal cable and said transmit and receive frequency converters for multiplexing in frequency a signal of the transmit intermediate frequency band and a signal of the receive intermediate frequency band; and

said second device comprising:

(11) AU-B-73306/87  
(10) 612977

-2-

a second frequency multiplexer connected to the other end of said signal cable; and

a demodulator and a modulator each being connected to a respective one of other two terminals of said second frequency multiplexer.

6 1 2 9 7 7

FORM 10

SPRUSON & FERGUSON

COMMONWEALTH OF AUSTRALIA

PATENTS ACT 1952

COMPLETE SPECIFICATION

(ORIGINAL)

FOR OFFICE USE:

Class

Int. Class

7 3 2 0 6 / 8 7

Complete Specification Lodged:

Accepted:

Published:

Priority:

Related Art:

---

Name of Applicant: NEC Corporation

Address of Applicant: 33-1, Shiba 5-chome, Minato-ku, Tokyo, Japan

Actual Inventor: OSAMU YAMAMOTO

Address for Service: Spruson & Ferguson, Patent Attorneys,  
Level 33 St Martins Tower, 31 Market  
Street, Sydney,  
New South Wales, 2000, Australia

Complete Specification for the invention entitled:

"TRANSMITTER/RECEIVER APPARATUS"

The following statement is a full description of this invention,  
including the best method of performing it known to us

SBR/JS/0075T

## TRANSMITTER/RECEIVER APPARATUS

### Background of the Invention

The present invention relates to a transmitter/receiver apparatus having application to microwave band communications such as satellite communication and, more particularly, to a transmitter/receiver apparatus which is miniature enough to be installed in, for example, the feeder section of an antenna.

While the tendency to apply satellite communication channels to commercial communications is increasing, a prerequisite for facilitating such an application is cutting down the cost and size of a transmitter/receiver apparatus. For example, a miniature transmitter/receiver apparatus which can be incorporated in the feeder section of an about 2 meters antenna is desired.

In a transmitter/receiver apparatus applicable to commercial communications which uses a microwave band, e.g., satellite communication, while the transmit level is on the order of 1 watt, the receive level is more than 100 dB lower than the transmit level. Hence, what is very important with this type of transmitter/receiver apparatus is setting up sufficiently isolation between discrete circuits in order to minimize interference from a transmit system to a receive system. However, in the case that miniaturization is intended presupposing the overall

dimensions of the apparatus housing, the freedom of circuit layout is so limited that the sufficient isolation between independent circuits is impracticable.

SUMMARY OF THE INVENTION

5 It is therefore an object of the present invention to provide a miniature and inexpensive transmitter/receiver apparatus which is satisfactorily applicable to microwave band communications even if the isolation between discrete circuits is insufficient.

10 According to one aspect of the present invention there is disclosed a transmitter/receiver apparatus comprising a first and a second device which are interconnected by a single signal cable;

said first device comprising:

a local oscillator for generating a local oscillation frequency at a predetermined position between a transmit and a receive frequency band;

15 a transmit frequency converter connected to said local oscillator for converting a transmit intermediate frequency band into said transmit frequency band based on said local oscillation frequency such that a transmit image frequency band of said transmit frequency band does not overlap said receive frequency band;

20 a receive frequency converter connected to said local oscillator for converting, based on the local oscillation frequency, the receive frequency band into a receive intermediate frequency band, which does not overlap the transmit intermediate frequency band, such that a receive image frequency band of said receive intermediate frequency band does not overlap the  
25 transmit frequency band, said frequency converter and said receive frequency converter being disposed separately from said local oscillator;  
and

a first frequency multiplexer connected between one end of the signal cable and said transmit and receive frequency converters for multiplexing  
30 in frequency a signal of the transmit intermediate frequency band and a signal of the receive intermediate frequency band; and

said second device comprising:

a second frequency multiplexer connected to the other end of said signal cable; and

35 a demodulator and a modulator each being connected to a respective one of other two terminals of said second frequency multiplexer.

HRF/0440y



The transmitter/receiver apparatus further comprises a frequency multiplexer which connects to the transmit and receive frequency converters a single cable over which a signal of the transmit intermediate frequency band and a signal of the receive intermediate frequency band are propagated in a frequency-multiplexed condition.

The local oscillator generates a local oscillation frequency at a position between a transmit frequency band and a receive frequency band and which is commonly applied to transmission and receipt, the local oscillation frequency being fed to the transmit and receive frequency converters.

The transmit frequency converter converts a transmit intermediate frequency band into the transmit frequency band based on the local oscillation frequency and such that its transmit image frequency band does not overlap the receive frequency band.

Further, the receive frequency converter converts, based on the local oscillation frequency, the receive frequency band into a receive intermediate frequency band, which does not overlap the transmit intermediate frequency band, such that its receive image frequency band does not overlap the transmit frequency band.

As a result, the receive intermediate frequency band, the transmit intermediate frequency band, the transmit image frequency band, the receive frequency band, the local oscillation frequency, the receive image frequency



band, and the transmit frequency band are distributed on a frequency axis without overlapping each other.

The frequency multiplexer connects a single signal cable to the transmit and receive frequency converters, multiplexes an incoming signal of the transmit intermediate frequency band and an outgoing signal of the receive intermediate frequency band, and allows intermediate frequency signals to be interchanged over the single signal cable.

Thus, in the transmitter/receiver apparatus of the present invention, the receive intermediate frequency band, the transmit intermediate frequency band, the transmit image frequency band, the receive frequency band, the local oscillation frequency, the receive image frequency band, and the transmit frequency band are so determined as not to overlap each other. Hence, interference due to migration from the transmit system to the receive system and others is eliminated even if the isolation between independent circuits is insufficient, whereby the transmitter/receiver apparatus is rendered simple and miniature. The transmit and receive systems share a single local oscillator to cut down the cost of the apparatus, compared to a prior art apparatus in which they are provided with an exclusive local oscillator each. Further, since a single signal cable suffices for the interchange of intermediate frequency signals, the cable and construction expenses are noticeably reduced. Hence, there can be implemented easily and

economically an arrangement wherein, for example, the apparatus of the present invention is mounted in an outside antenna feeder section and connected to an indoor main equipment by a single signal cable.

5 Brief Description of the Drawings

Fig. 1 is a block diagram of a transmitter/receiver apparatus embodying the present invention;

Fig. 2 is a view of a frequency distribution; and

Fig. 3 is a side elevation showing the apparatus  
10 of Fig. 1 which is installed in the feeder section of an antenna by way of example.

Detailed Description of Preferred Embodiment

Referring to Fig. 1 of the drawings, a transmitter/receiver apparatus in accordance with the present  
15 invention is shown and generally designated by the reference numeral 100. The apparatus 100 has a miniature box-like configuration and may be mounted in, for example, the feeder section of an outdoor antenna 1. Basically, the apparatus 100 comprises a local oscillator 2, a  
20 duplexer 3, a low noise amplifier 4, a receive frequency converter 5, a transmit frequency converter 6, a power amplifier 7, and a frequency multiplexer 8. The frequency multiplexer 8 is connected by a single signal cable, e.g., a coaxial cable 9 to a frequency multiplexer 10 of indoor  
25 main equipment 101. Connected to the frequency multiplexer

10 are a demodulator 11 and a modulator 12.

The local oscillator 2 oscillates a local oscillation frequency LO at a predetermined position between a transmit frequency band T and a receive frequency band R. The local oscillation frequency LO is fed to the transmit and receive frequency converters 6 and 5. Specially, assuming that the transmit frequency T lies in a range of 14.0 to 14.5 GHz and the receive frequency R in a range of 11.7 to 12.2 GHz by way of example, the local oscillation frequency LO is preselected to be 12.7 GHz.

A signal modulated by the modulator 12 and whose frequency lies in a transmit intermediate frequency band TIF is fed to the transmit frequency converter 6 via the frequency multiplexer 10 of the indoor equipment 101, the signal cable 9, and the frequency multiplexer 8. The transmit frequency converter 6 converts the input signal having the frequency T into a signal which belongs to the transmit frequency band T, based on the local oscillation frequency LO such that its transmit image frequency TIMG does not overlap the receive frequency band R. The signal with the frequency T is amplified by the power amplifier 7 and, then, radiated from the antenna 1 toward a satellite. In this particular embodiment, the transmit intermediate frequency band TIF ranges from 1.3 to 1.8 GHz while the transmit image frequency band TIMG ranges from 10.9 to 11.4 GHz.

A signal coming in through the antenna 1 and lying in the receive frequency band R is routed through the duplexer 3 and low noise amplifier 4 to the receive frequency converter 5. This converter 5 converts, based on the local oscillation frequency LO, the signal of the receive frequency band R into a signal whose frequency lies in a receive intermediate frequency band RIF, which does not overlap the transmit intermediate frequency band TIF, such that its receive image frequency band RIMG does not overlap the transmit frequency band T. The output of the receive frequency converter 5 is delivered to the indoor equipment 101 via the frequency multiplexer 8, signal cable 9, and frequency multiplexer 10. In this particular embodiment, the receive intermediate frequency band RIF ranges from 0.5 to 1.0 GHz, and the receive image frequency band RIMG ranges from 13.2 to 13.7 GHz.

Fig. 2 shows the consequent distribution of frequencies which are generated in the transmit and receive systems of the transmitter/receiver apparatus 100. As shown, the receive intermediate frequency band RIF (0.5 to 1.0 GHz), the transmit intermediate frequency band TIF (1.3 to 1.8 GHz), the transmit image frequency band TIMG (10.9 to 11.4 GHz), the receive frequency band R (11.7 to 12.2 GHz), the local oscillation frequency LO (12.7 GHz), the receive image frequency band RIMG (13.2 to 13.7 GHz) and the transmit frequency band T (14.0 to 14.5 GHz) are sequentially

arranged on the frequency axis without overlapping each other.

In short, the present invention implements a transmit and a receive system with a common local oscillation source and, thereby, cuts down the cost, compared to a case  
5 wherein two independent local oscillation sources are used. Since different intermediate frequency bands are adopted for transmission and receipt, interference from the transmit system to the receive system is eliminated even  
10 if the isolation between discrete circuits is incomplete, as would occur if a transmit/receive apparatus were installed in a small housing. Furthermore, that the transmit image frequency band does not overlap the receive frequency band and the transmit image frequency band also  
15 protects the apparatus against interference. Consequently, a simple, miniature and inexpensive transmitter/receiver apparatus is achieved.

Since the transmit and receive intermediate frequencies are different from each other as stated above, intermediate  
20 frequency signals can be interchanged between the outdoor apparatus 100 and the indoor main equipment 101 over the single cable 9 by multiplexing signals which belong to those different frequency bands. Each of the frequency multiplexers 8 and 10 has a frequency multiplexing function  
25 and a signal interchanging function. Such allows the single cable 9 to suffice when the apparatus 100 is to be

placed outside of a building and connected to the indoor equipment 101.

As shown in Fig. 3, the transmitter/receiver apparatus 100 is miniature enough to be installed even in, for example, the feeder section of an antenna and, therefore, easy to mount. Such remarkably cuts down the total cost of an antenna and others to which the apparatus 100 is applicable.

In Fig. 3, there are shown the cable, e.g., a coaxial cable 9 adapted to interconnect the outdoor transmitter/receiver apparatus 100 and the indoor equipment 101, a primary radiator, or horn, 111 mounted on the apparatus 100, a parabolic reflector 112 of the antenna, support members 113 for supporting the apparatus 100, a framework 114 for supporting the whole antenna with the apparatus 100, a mechanism 115 for adjusting the elevation of the antenna, and an antenna support post. Basically, the illustrative configuration constitutes an offset parabolic antenna. To align the antenna pointing to a direction of wave arrival, the azimuth is adjusted by the post 116 and the elevation by the elevation adjusting mechanism 115.

For an arrangement relating to the present invention, a reference may be made to U.S. Patent Application (Serial No. 831,667) which is assigned to the applicant of the present invention.

As described above, in a transmitter/receiver apparatus of the present invention, a receive intermediate frequency band, a transmit intermediate frequency band, a transmit image frequency band, a receive frequency band, a local oscillation frequency, a receive image frequency band, and a transmit frequency band are so determined as not to overlap each other. Hence, interference from a transmit system to a receive system and others is eliminated even if the isolation between independent circuits is insufficient, whereby the transmitter/receiver apparatus is rendered simple and miniature. The transmit and receive systems share a single local oscillator to cut down the cost of the apparatus, compared to a prior art apparatus in which they are provided with an exclusive local oscillator each. Further, since a single signal cable suffices for the interchange of intermediate frequency signals, the cable and construction expenses are noticeably reduced. Hence, there can be implemented easily and economically an arrangement wherein, for example, the apparatus of the present invention is mounted in an outside antenna feeder section and connected to an indoor main equipment by a single signal cable.

The claims defining the invention are as follows:

1. A transmitter/receiver apparatus comprising a first and a second device which are interconnected by a single signal cable;

said first device comprising:

5 a local oscillator for generating a local oscillation frequency at a predetermined position between a transmit and a receive frequency band;

a transmit frequency converter connected to said local oscillator for converting a transmit intermediate frequency band into said transmit frequency band based on said local oscillation frequency such that a  
10 transmit image frequency band of said transmit frequency band does not overlap said receive frequency band;

a receive frequency converter connected to said local oscillator for converting, based on the local oscillation frequency, the receive frequency band into a receive intermediate frequency band, which does not overlap the  
15 transmit intermediate frequency band, such that a receive image frequency band of said receive intermediate frequency band does not overlap the transmit frequency band, said frequency converter and said receive frequency converter being disposed separately from said local oscillator;  
and

20 a first frequency multiplexer connected between one end of the signal cable and said transmit and receive frequency converters for multiplexing in frequency a signal of the transmit intermediate frequency band and a signal of the receive intermediate frequency band; and

said second device comprising:

25 a second frequency multiplexer connected to the other end of said signal cable; and

a demodulator and a modulator each being connected to a respective one of other two terminals of said second frequency multiplexer.

30 2. A transmitter/receiver apparatus as claimed in claim 1, wherein the first device is located outside of a building and the second device inside of said building.

3. A transmitter/receiver apparatus as claimed in claim 1, wherein the first device is mounted in a feeder section of an antenna.

35 4. A transmitter/receiver apparatus as claimed in claim 1, wherein the signal cable comprises a coaxial cable.





5. A transmitter/receiver apparatus substantially as described with reference to the accompanying drawings.

DATED this THIRD day of MAY 1991  
NEC CORPORATION

Patent Attorneys for the Applicant  
SPRUSON & FERGUSON

5

10

15

20

25

30

35

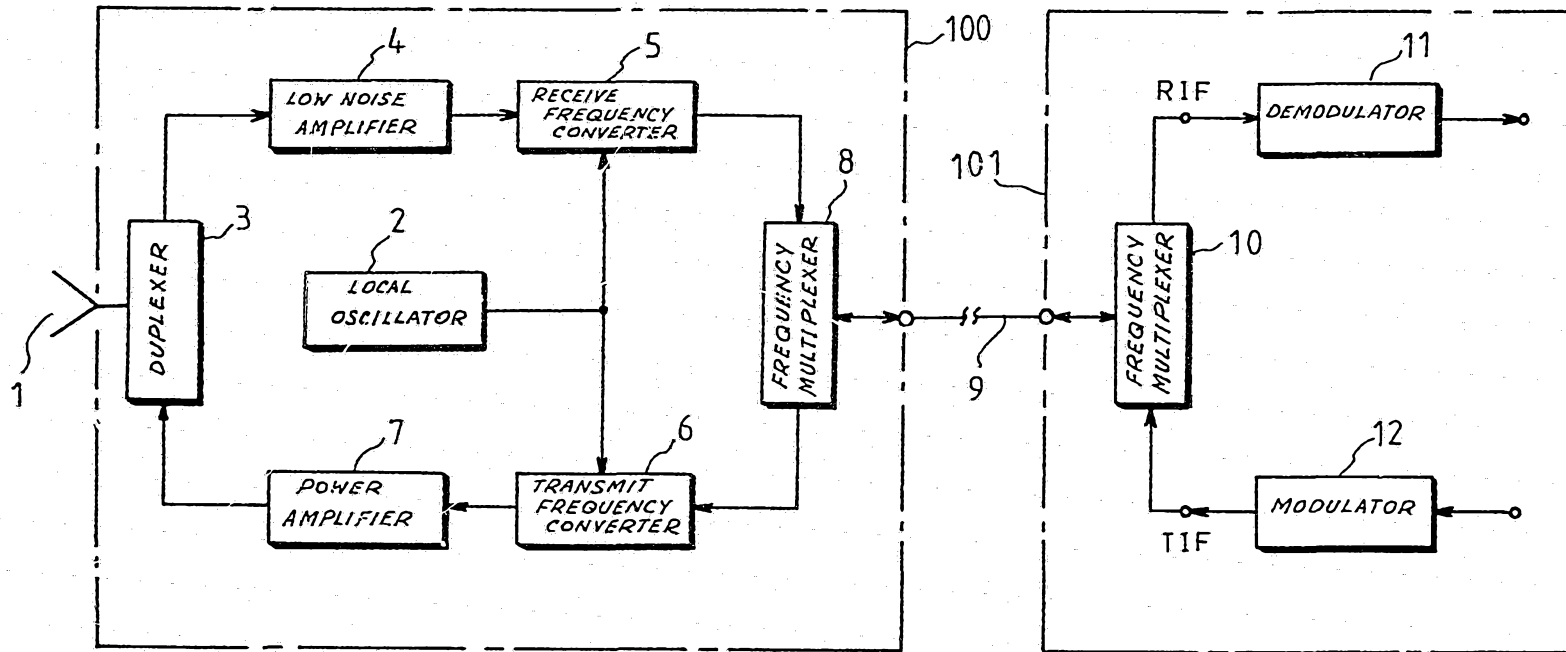

FIG. 1

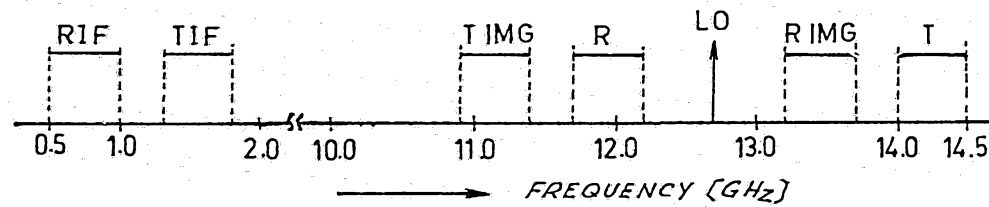

FIG. 2

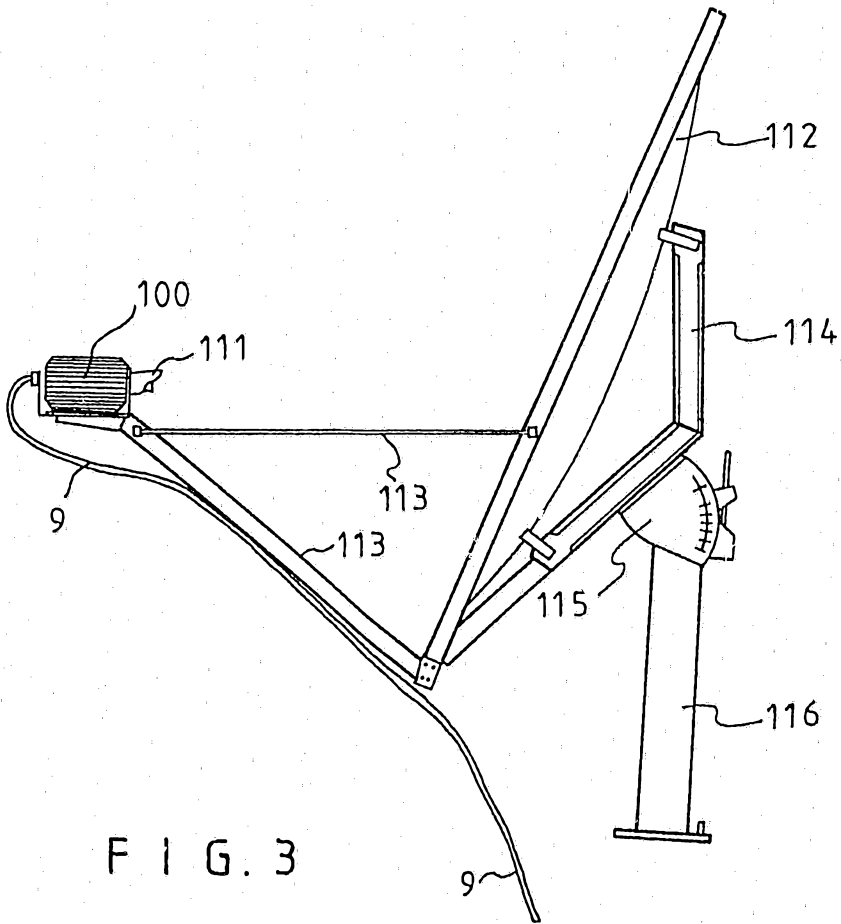

FIG. 3

To or from 101