



US00D719503S

(12) **United States Design Patent**
Kouyanagi et al.

(10) **Patent No.:** **US D719,503 S**

(45) **Date of Patent:** **** Dec. 16, 2014**

(54) **SOLAR BATTERY AFFIXING FRAME**

Primary Examiner — Derrick Holland

(71) Applicant: **SANYO Electric Co., Ltd.**,
Moriguchi-shi, Osaka (JP)

(74) *Attorney, Agent, or Firm* — Westerman, Hattori,
Daniels & Adrian, LLP

(72) Inventors: **Masao Kouyanagi**, Izumiotsu (JP);
Shingo Okamoto, Toyonaka (JP)

(57) **CLAIM**

(73) Assignee: **SANYO Electric Co., Ltd.**,
Moriguchi-shi (JP)

The ornamental design for a solar battery affixing frame, as shown and described.

(**) Term: **14 Years**

(21) Appl. No.: **29/455,621**

DESCRIPTION

(22) Filed: **May 22, 2013**

(30) **Foreign Application Priority Data**

Nov. 22, 2012 (JP) 2012-028617

(51) **LOC (10) CL.** **13-02**

(52) **U.S. CL.**
USPC **D13/102**

(58) **Field of Classification Search**

USPC D13/102, 101, 103, 107, 118, 184, 199;
D25/60, 61, 156, 199; 52/74, 78,
52/173.3; 126/569, 605, 606, 608,
126/621–623; 136/206, 243–246, 251, 259;
320/101

See application file for complete search history.

(56) **References Cited**

U.S. PATENT DOCUMENTS

3,457,427 A * 7/1969 Tarneja et al. 250/239
D260,679 S * 9/1981 Mayerovitch D13/102
6,528,718 B2 * 3/2003 Yoda et al. 136/251
D588,534 S * 3/2009 Sharma et al. D13/102
2004/0084078 A1 * 5/2004 Yoshida et al. 136/251
2008/0222988 A1 * 9/2008 Lee 52/588.1

FOREIGN PATENT DOCUMENTS

JP 2011453899 S 10/2012

* cited by examiner

FIG. 1 is a perspective view of a first embodiment of a solar battery affixing frame showing our new design;
FIG. 2 is a top plan view thereof;
FIG. 3 is a bottom plan view thereof;
FIG. 4 is a front elevational view thereof, the rear elevational view being a mirror image thereof;
FIG. 5 is a right side elevational view thereof, the left side elevational view being a mirror image thereof;
FIG. 6 is a cross-sectional view thereof taken along lines 6-6 of FIG. 2;
FIG. 7 is a cross-sectional view thereof taken along lines 7-7 of FIG. 2;
FIG. 8 is a perspective view of a second embodiment of a solar battery affixing frame;
FIG. 9 is a top plan view thereof;
FIG. 10 is a bottom plan view thereof;
FIG. 11 is a front elevational view thereof, the rear elevational view being a mirror image thereof;
FIG. 12 is a right side elevational view thereof, the left side elevational view being a mirror image thereof;
FIG. 13 is a cross-sectional view thereof taken along lines 13-13 of FIG. 9; and,
FIG. 14 is a cross-sectional view thereof taken along lines 14-14 of FIG. 9.
The broken lines shown represent unclaimed subject matter and form no part of the claimed design. The dot-dash lines represent the boundaries between the claimed and unclaimed portions of the solar battery affixing frame.

1 Claim, 14 Drawing Sheets

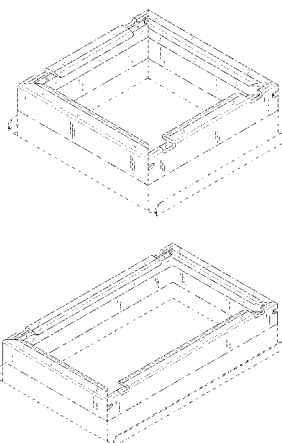

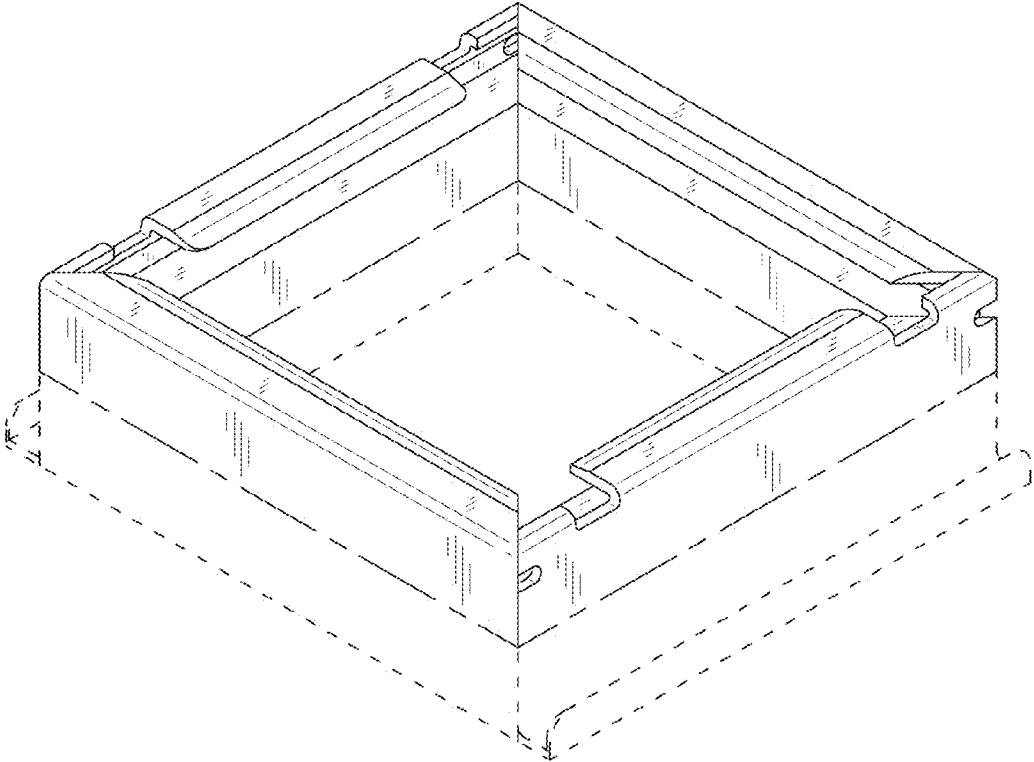

FIG.1

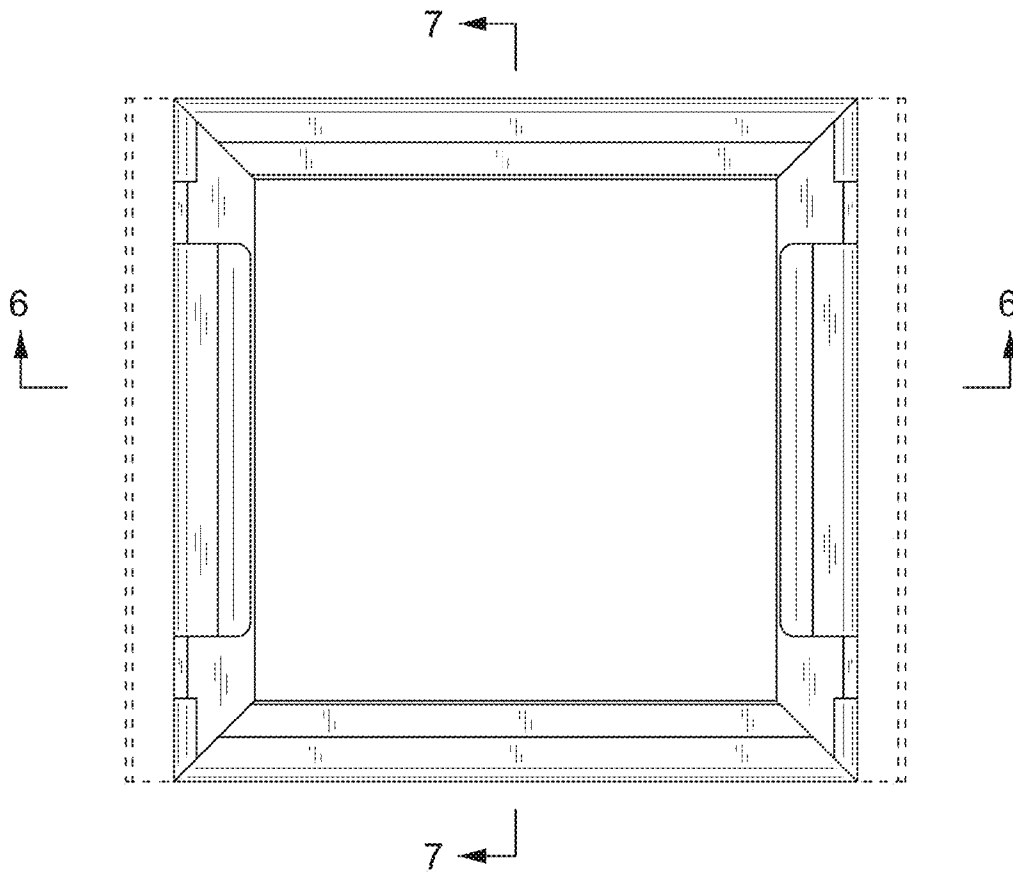

FIG.2

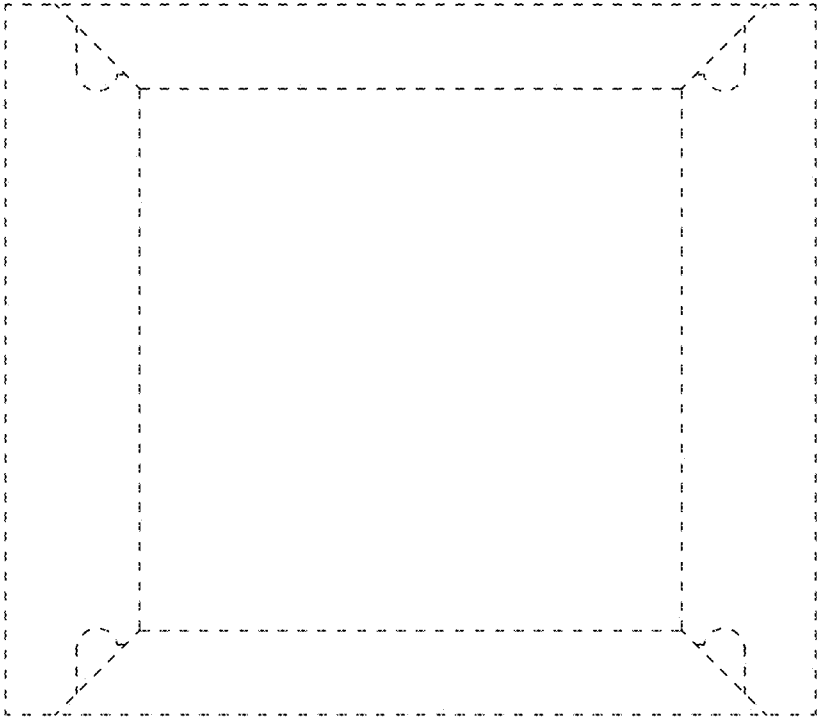

FIG.3

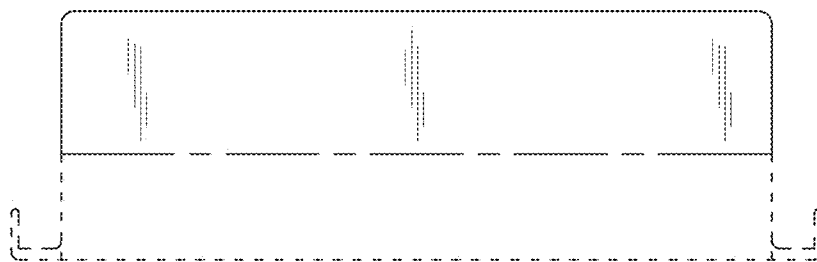

FIG.4

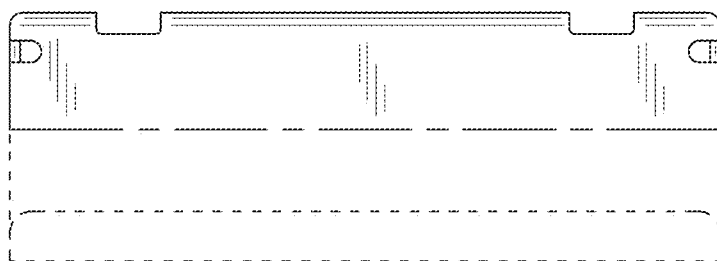

FIG.5

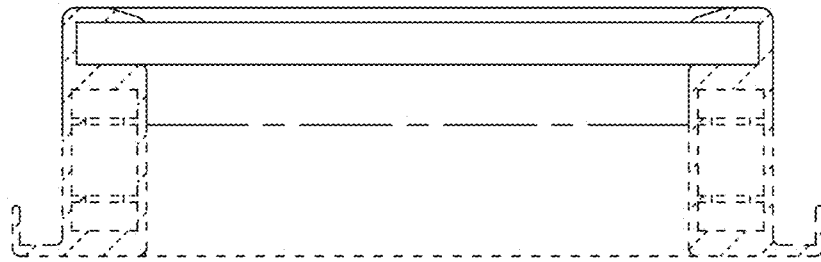

FIG.6

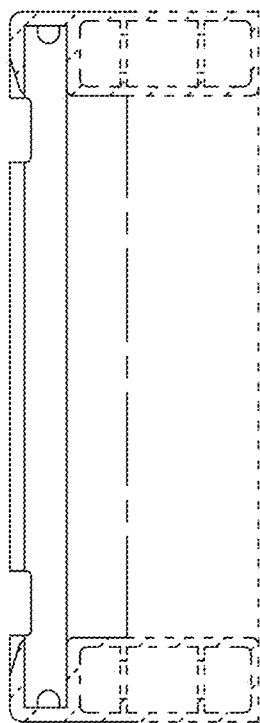

FIG.7

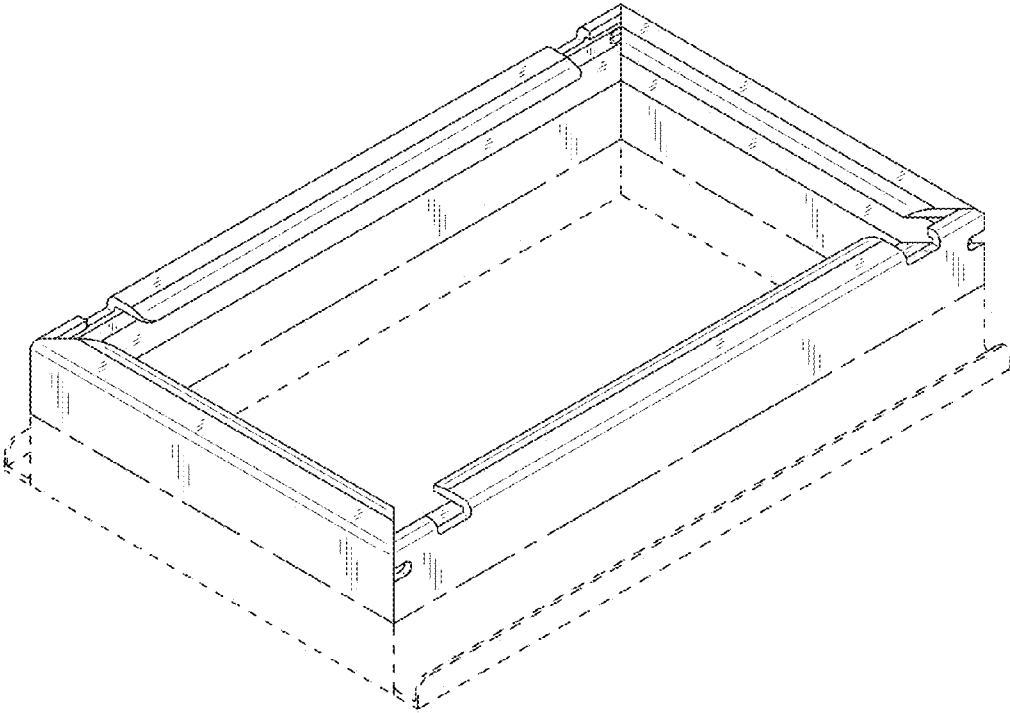

FIG.8

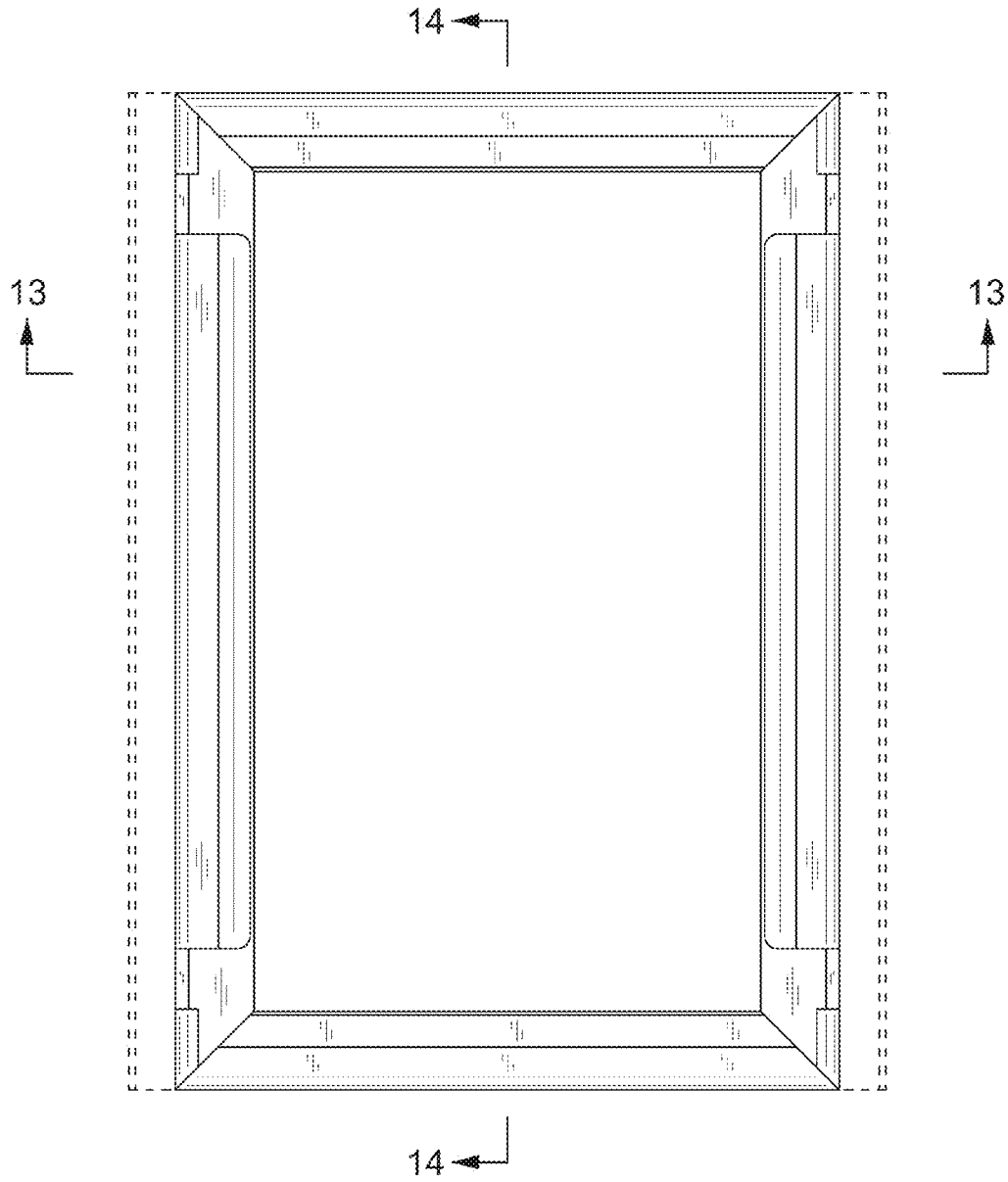

FIG.9

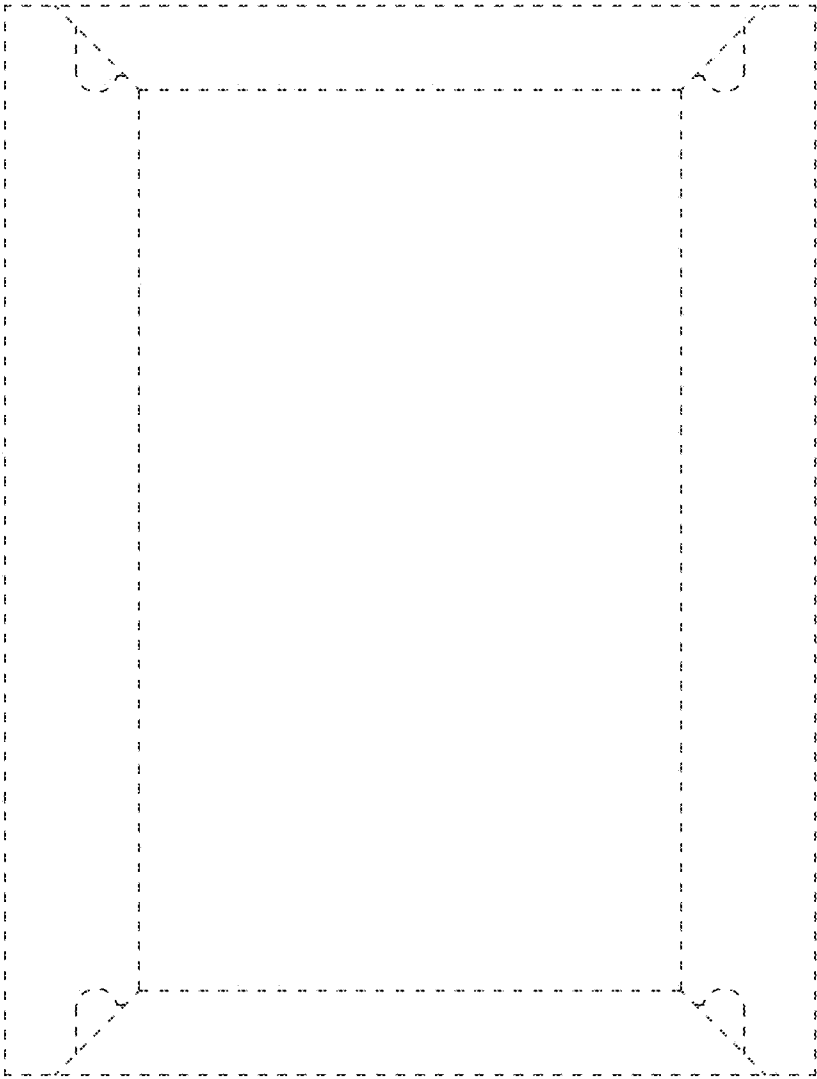

FIG.10

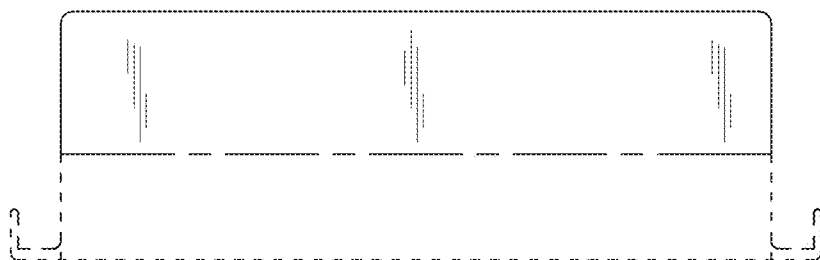

FIG. 11

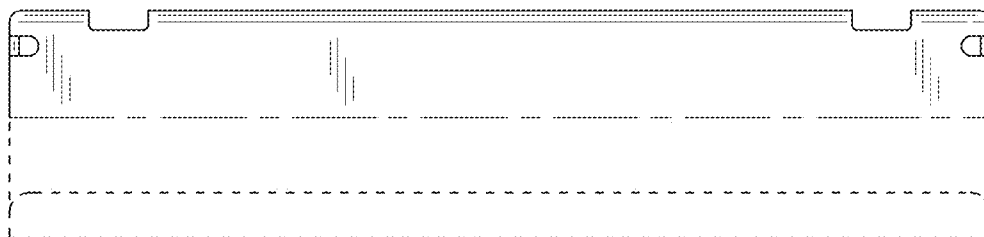

FIG.12

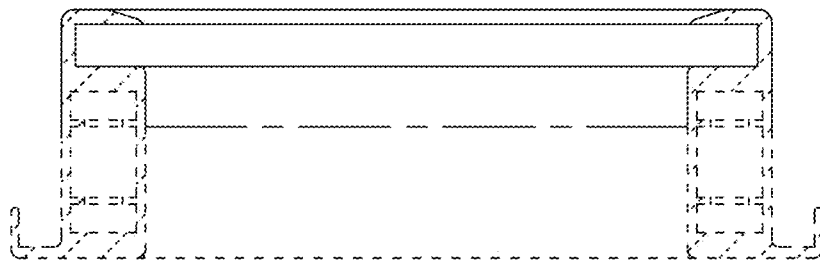

FIG.13

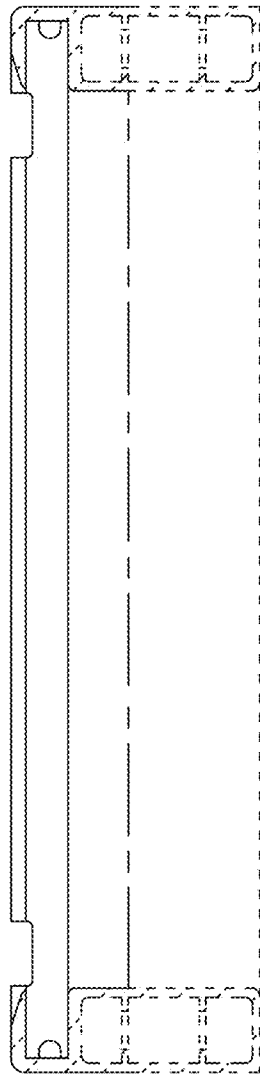

FIG.14